

	SC PATH'S ROUT SRL Telefon: 0256-216633, 291032 500400 TIMISOARA, Str. Ezzelle 92 E-mail: secretariat@pathsrou.ro ORC J 35220/1995, CUI: RO7267048 Capital social: 640.000 lei		Proiect: EXTINDEREA LA 4 BENZI STRADA PROF.DR. AUREL PAUNESCU-PODEANU Loc constr: STRADA AUREL PAUNESCU-PODEANU Beneficiar: MUNICIPIUL TIMISOARA	Nr.proiect: 14.014/1
	DIRECTOR Ing. PERCEC VASILE	SCARA 1:1.000	Planşa: PROFIL LONGITUDINAL	Nr.plan 02D

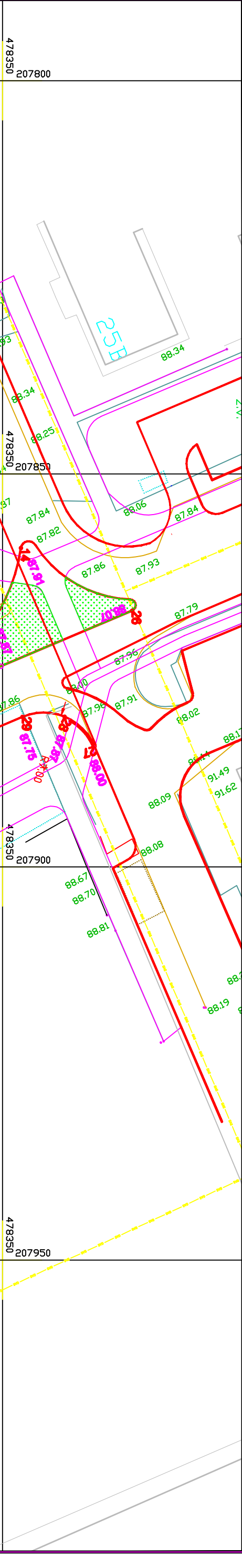

MUNICIPIUL CALABRĂRITZE
PLANUL DE COORDONATE

P	Est	Nord	Z
1	207870.950	478273.659	86.68
2	207870.431	478279.473	86.78
3	207870.370	478284.262	86.92
4	207871.224	478288.975	87.06
5	207872.146	478296.740	87.24
6	207870.624	478304.411	87.45
7	207869.721	478313.355	87.54
8	207873.256	478321.621	87.61
9	207875.453	478325.929	87.65
10	207874.574	478332.622	87.69
11	207872.792	478337.069	87.72
12	207862.964	478346.742	87.78
13	207849.175	478346.621	87.84
14	207859.430	478352.924	87.91
15	207869.956	478347.872	87.87
16	207876.936	478338.823	87.83
17	207878.818	478334.375	87.80
18	207880.010	478329.354	87.78
19	207879.487	478324.220	87.75
20	207880.569	478323.362	87.74
21	207883.778	478324.644	87.70
22	207887.199	478325.330	87.67
23	207885.648	478328.589	87.69
24	207882.094	478333.082	87.75
25	207879.398	478338.137	87.81
26	207867.407	478336.477	88.07
27	207884.625	478361.684	88.00
28	207880.873	478357.867	87.87
29	207880.916	478352.514	87.75
30	207889.397	478332.469	87.59
31	207891.282	478325.558	87.57
32	207894.448	478324.665	87.54
33	207893.020	478326.994	87.52
34	207897.988	478325.272	87.47
35	207900.576	478323.019	87.46
36	207905.953	478319.387	87.43
37	207912.361	478318.367	87.40
38	207918.964	478312.753	87.58
39	207915.459	478312.483	87.56
40	207909.828	478312.403	87.56
41	207902.796	478314.210	87.58
42	207901.750	478313.385	87.58
43	207902.012	478310.828	87.57
44	207901.819	478308.264	87.37
45	207903.255	478307.208	87.37
46	207911.157	478309.924	87.47
47	207916.259	478310.989	87.54
48	207919.394	478311.308	87.58
49	207936.559	478307.801	87.56
50	207931.368	478307.215	87.52
51	207913.094	478304.179	87.35
52	207906.022	478301.893	87.22
53	207899.937	478297.608	87.22
54	207894.814	478294.180	87.22
55	207888.835	478292.682	87.22
56	207882.935	478290.430	87.20
57	207879.246	478285.305	87.00
58	207878.032	478279.935	86.84
59	207877.804	478274.406	86.68
60	207874.543	478274.051	86.62
61	207877.496	478289.630	87.23
62	207881.460	478293.682	87.30
63	207876.661	478296.273	87.35
64	207876.131	478290.182	87.23
65	207884.359	478302.204	87.46
66	207892.098	478302.889	87.34
67	207896.481	478311.400	87.49
68	207893.911	478316.964	87.59
69	207887.948	478319.623	87.69
70	207882.929	478318.378	87.77
71	207879.496	478306.544	87.56
CG	207887.514	478310.633	87.66

NOTA:
 1. Coordonatele Est (X) și Nord (Y) sunt în sistemul STEREO20
 2. Cota Z se referă la cota suprafeței a terenului cu înălțimea față
 de nivelul mării. Cota pantii convenite este de 1,5 m sub cota suprafeței a
 terenului.
 3. Cota guler de scurgere se referă la cota de montare a gulerului, care
 este cu 2 cm sub cota convenită.

parcare

CP
A45
B

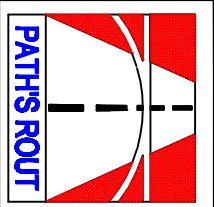

SC PATH'S ROUT SRL
 Tel: 0256-210633, 291052
 300430 TIMISOARA, Str. E. Zola 92
 E-mail: secretariat@pathsrout.ro
 ORC J 35729/1966, CUI: R07267049
 Capital social: 640.000 lei



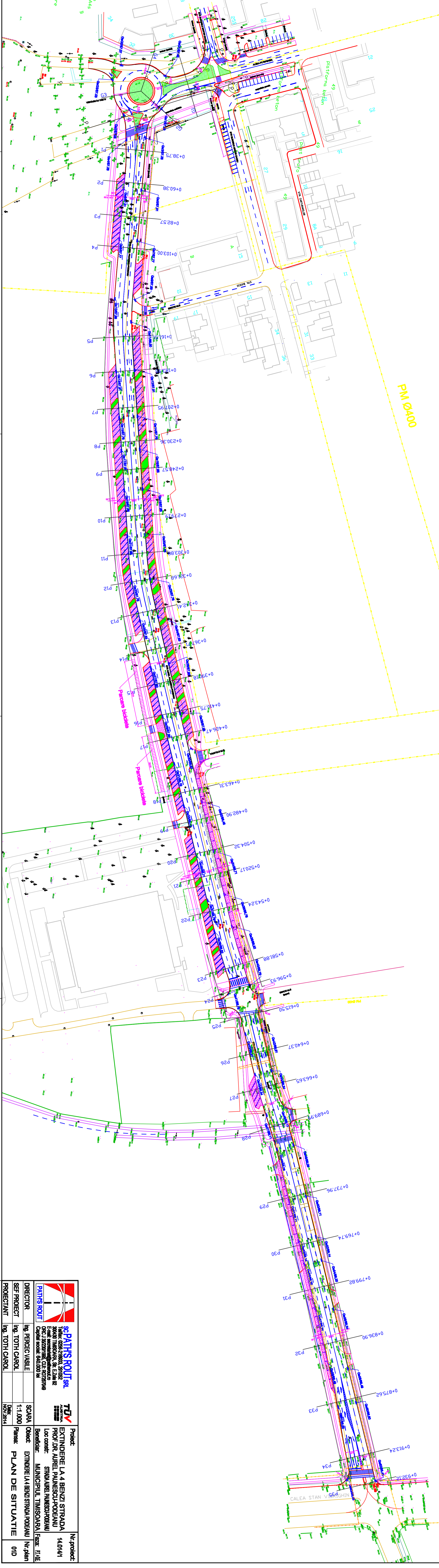

Proiect: EXTINDEREA LA 4 BENZI STRADA PROF. DR. AUREL PAUNESCU-PODEANU
Loc constr: STRADA AUREL PAUNESCU-PODEANU
Beneficiar: MUNICIPIUL TIMISOARA
Faza: P.I. + I.E.

DIRECTOR	Ing. PERCEC VASILE	SCARA	1:500
SEF PROIECT	Ing. TOTI CAROL	Data:	NOV.2014
PROIECTANT	Ing. TOTI CAROL	Obiect:	EXTINDEREA LA 4 BENZI STRADA PODEANU
		Planşa:	DETALIU TRASARE GIRATIE
		Nr. proiect:	14.014/1
		Nr. plan	07D

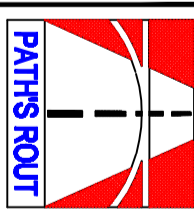

PM Ø400

 <p>SC PATHS ROUT SRL Telefon: 0256-210883, 281022 300430 TIMISOARA, Str. E. Zărnă 82 E-mail: secretariat@pathsroute.ro ONC J. 552201/1995, CUI: R07287049 Capital social: 640.000 lei</p>		 <p>TV Asociația Inginerilor Topografi din România</p>		Proiect: EXTINDEREA LA 4 BENZI STRADA PROF. DR. AUREL PAUNESCU-PODEANU Loc. constr.: STRADA AUREL PAUNESCU-PODEANU Beneficiar: MUNICIPALITATEA TIMISOARA		Nr. proiect: 14.01/1 Scara: 1:1.000 Data: NOV 2014	
Director: Ing. PERCEC VASILE Sef proiect: Ing. TOTI CAROL Proiectant: Ing. TOTI CAROL		Obiect: EXTINDEREA LA 4 BENZI STRADA PODEANU Planșă: PLAN DE SITUATIE		Nr. plan: 010			

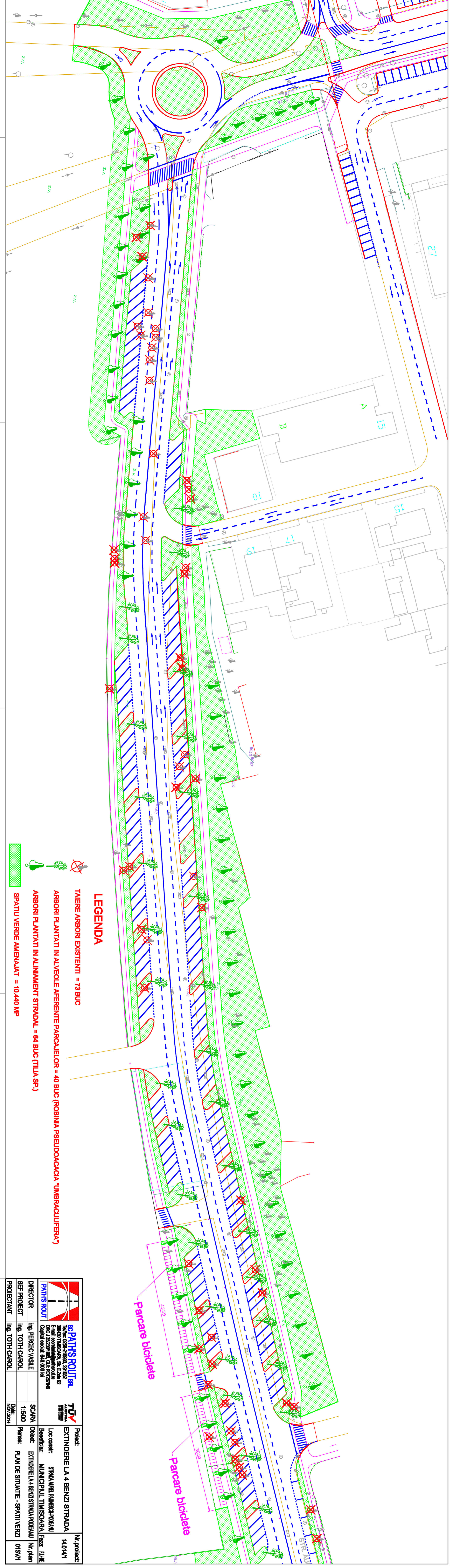

LEGENDA

- TAIERE ARBORI EXISTENTI = 73 BUC
- ARBORI PLANTATI IN ALVEOLE AFERENTE PARCALELOR = 40 BUC (ROBINIA PSEUDOCACAIA 'UMBRAULIFERA')
- ARBORI PLANTATI IN ALINAMENT STRADAL = 64 BUC (TILIA SP.)
- SPATIU VERDE AMENAJAT = 10.440 MP

 sp PATH'S ROUT SRL Sediul societății: Timișoara, Str. E.226 nr. 2 Sediul societății: Timișoara, Str. E.226 nr. 2 Capital social: 60.000 RON		 TÜV Timișoara Sediul societății: Timișoara, Str. E.226 nr. 2 Sediul societății: Timișoara, Str. E.226 nr. 2 Capital social: 60.000 RON	
Proiect:	EXTINDERE LA 4 BENZI STRADA	Nr. proiect:	14.0141
Loc. comar:	STRADA ALB. I. VANCEA (ROZARIU)	Beneficiar:	MUNICIPALITATEA TIMISOARA
Beneficiar:	MUNICIPALITATEA TIMISOARA	Scara:	1:500
Proiectant:	ING. TOH CAROL	Planșă:	PLAN DE SITUATIE - SPATII VERZI
Director:	ING. PERCEC VASILE	Scara:	1:500
Sef proiect:	ING. TOH CAROL	Planșă:	PLAN DE SITUATIE - SPATII VERZI
Proiectant:	ING. TOH CAROL	Data:	10/05/2011

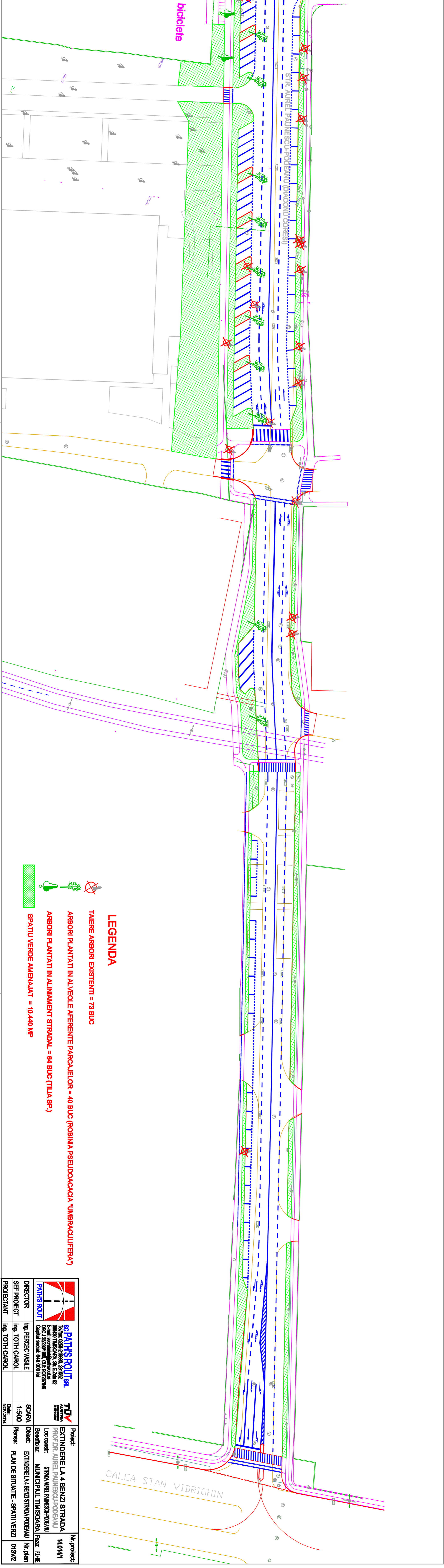



LEGENDA

- TAIERE ARBORI EXISTENTI = 73 BUC
- ARBORI PLANTATI IN ALVEOLE AFERENTE PARCALELOR = 40 BUC (ROBINIA PSEUDOCACAIA 'UMBRAULIFERA')
- ARBORI PLANTATI IN ALINAMENT STRADAL = 64 BUC (TILIA SP.)
- SPATIU VERDE AMENAJAT = 10.440 MP

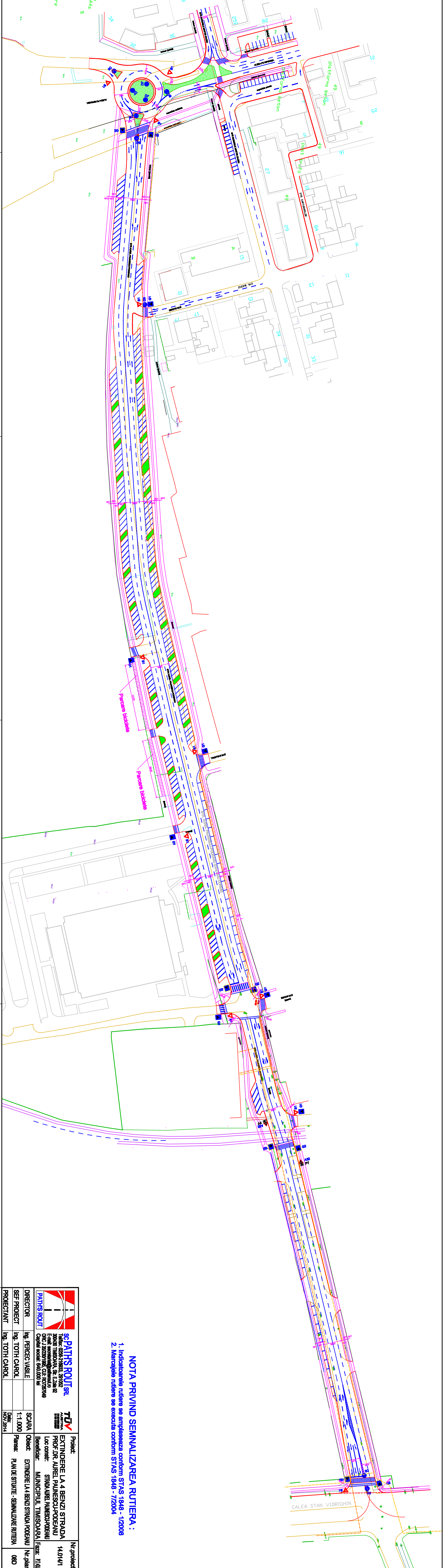
 sp PATH'S ROUT SRL Sediul societății: Timișoara, Str. E.226 nr. 2 Sediul societății: Timișoara, Str. E.226 nr. 2 Capital social: 60.000 RON		 TÜV Timișoara Sediul societății: Timișoara, Str. E.226 nr. 2 Sediul societății: Timișoara, Str. E.226 nr. 2 Capital social: 60.000 RON	
Proiect:	EXTINDERE LA 4 BENZI STRADA	Nr. proiect:	14.0141
Loc. comar:	STRADA ALB. I. VANCEA (ROZARIU)	Beneficiar:	MUNICIPALITATEA TIMISOARA
Beneficiar:	MUNICIPALITATEA TIMISOARA	Scara:	1:500
Proiectant:	ING. TOH CAROL	Planșă:	PLAN DE SITUATIE - SPATII VERZI
Director:	ING. PERCEC VASILE	Scara:	1:500
Sef proiect:	ING. TOH CAROL	Planșă:	PLAN DE SITUATIE - SPATII VERZI
Proiectant:	ING. TOH CAROL	Data:	10/05/2011



NOTA PRIVIND SEMNALIZAREA RUTIERA :
 1. Indicatoarele rutiere se amplaseaza conform STAS 1848 - 7/2008
 2. Marjelele rutiere se executa conform STAS 1848 - 7/2004

 SC PATHS ROUT SRL Telefon: 0256-210603, 281022 300430 TIMISOARA, Str. E.248 82 E-mail: secretariat@pathsroutr.ro ONC J.55220/1995, CUI: R07267049 Capital social: 640.000 lei		 TVV AURELIA SINGH ING. ARHITECT Loc constr: STRADA ALBET PAUNESCU-PODEANU Beneficiar: MUNICIPIUL TIMISOARA Faza: P.01E		Nr. proiect: 14.014/1	
DIRECTOR	Ing. PERCEC VASILE	SCARA	Obiect:	EXTINDERE LA 4 BENZI STRADA PODEANU	Nr. plan
SEF PROIECT	Ing. TOTI CAROL	1:1.000	Planșe:	PLAN DE SITUAȚIE - SEMNALIZARE RUTIERA	080
PROIECTANT	Ing. TOTI CAROL	Data: NOV/2014			

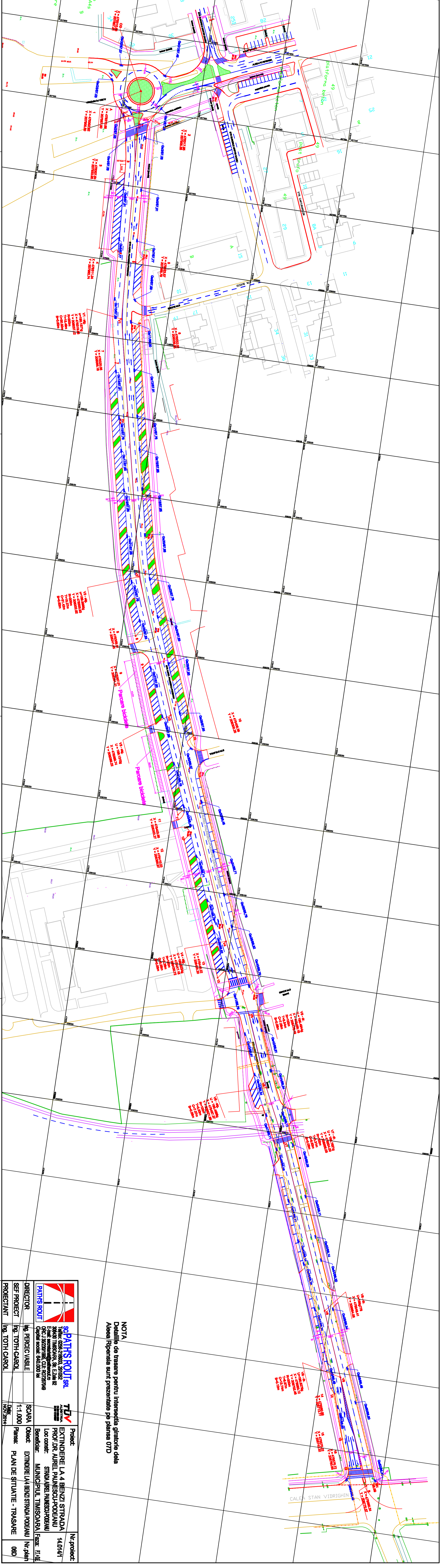

NOTA
 Detalii de trasare pentru intersectia giratorie dela
 Aleea Ripensia sunt prezentate pe planşa 07D

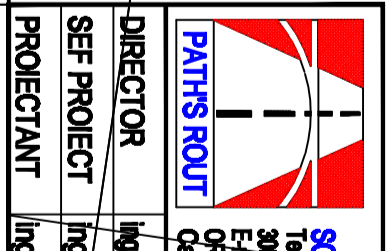
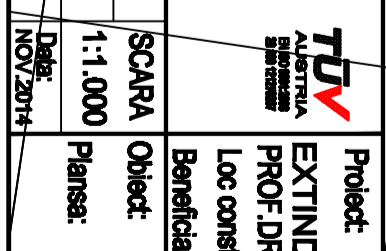
		SC PATHS ROUT SRL Tel: 0256-218833, 281022 300430 TIMISOARA, Str. E.248 82 E-mail: secretariat@pathsroutr.ro ONC J. 55/2011/195, C.I.E. R07287149 Capital social: 640.000 lei				TV ALTETRA ALTETRA ALTETRA ALTETRA		Nr. proiect: 14.074/1	
DIRECTOR Ing. PERCEC VASILE		SEF PROIECT Ing. TOITH CAROL		PROIECTANT Ing. TOITH CAROL		Obiect: EXTINDERE LA 4 BENZI STRADA Beneficiar: MUNICIPIUL TIMISOARA (Faza: P1-01)		Nr. plan 080	
SCARA 1:1.000		Planşa: PLAN DE SITUATIE - TRASARE		Data: NOV 2014		Loc constr: STRADA ALEA PAUNESCU-PODEANU Municipiul Timisoara		Nr. proiect: 14.074/1	

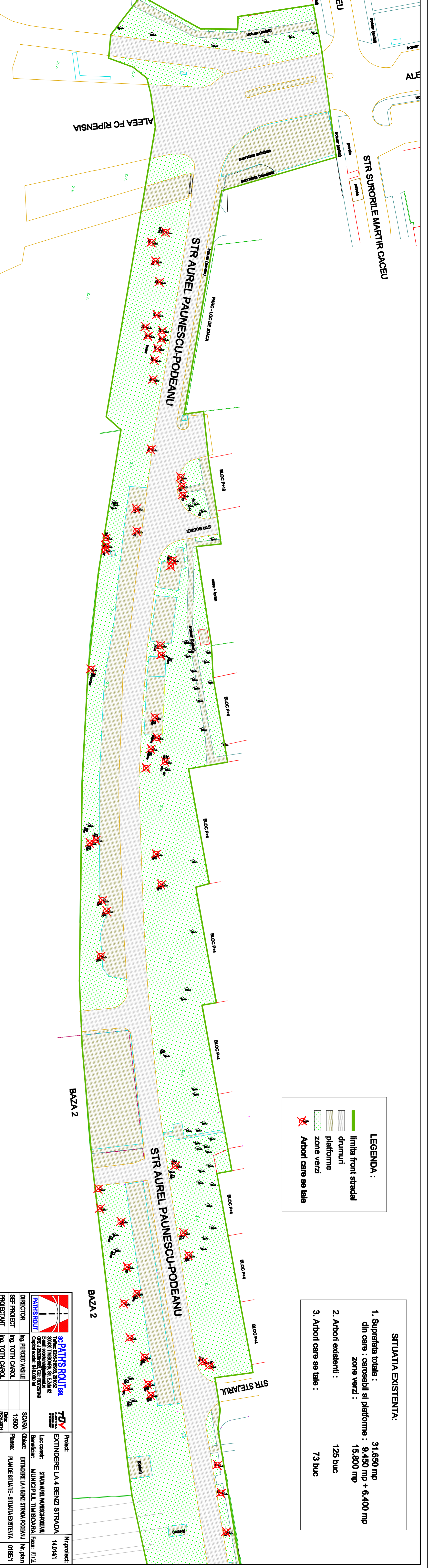

LEGENDA :

- limita front stradal
- drumuri
- platforme
- zone verzi
- Arbori care se tale

SITUATIA EXISTENTA:

1. Suprafata totala : 31.650 mp
din care : carosabli si platforme : 9.450 mp + 6.400 mp
zone verzi : 15.800 mp
2. Arbori existenti : 125 buc
3. Arbori care se tale : 73 buc

Proiect: EXTINDERE LA 4 BENZI STRADA Loc constr: STRADA PAUNESCU-PODEANU Beneficiar: MUNICIPIUL TIMISOARA Nr. plan: 0185/1		Proiect: EXTINDERE LA 4 BENZI STRADA Loc constr: STRADA PAUNESCU-PODEANU Beneficiar: MUNICIPIUL TIMISOARA Nr. plan: 0185/1	
SEF PROIECT	Ing. TOITH CAROL	SCARA	1:500
PROIECTANT	Ing. TOITH CAROL	Phase	PLAN DE SITUATIE - SITUATIA EXISTENTA

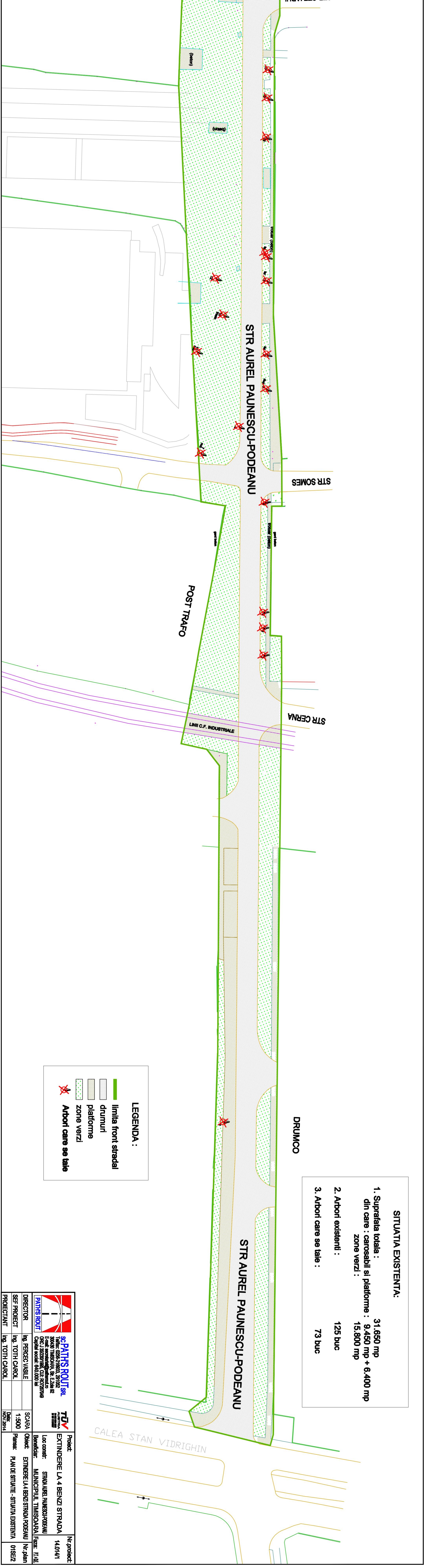

LEGENDA :

- limita front stradal
- drumuri
- platforme
- zone verzi
- Arbori care se tale

SITUATIA EXISTENTA:

1. Suprafata totala : 31.650 mp
din care : carosabli si platforme : 9.450 mp + 6.400 mp
zone verzi : 15.800 mp
2. Arbori existenti : 125 buc
3. Arbori care se tale : 73 buc

Proiect: EXTINDERE LA 4 BENZI STRADA Loc constr: STRADA PAUNESCU-PODEANU Beneficiar: MUNICIPIUL TIMISOARA Nr. plan: 0185/1		Proiect: EXTINDERE LA 4 BENZI STRADA Loc constr: STRADA PAUNESCU-PODEANU Beneficiar: MUNICIPIUL TIMISOARA Nr. plan: 0185/1	
SEF PROIECT	Ing. TOITH CAROL	SCARA	1:500
PROIECTANT	Ing. TOITH CAROL	Phase	PLAN DE SITUATIE - SITUATIA EXISTENTA

SECTIUNEA 1 G1 - G2

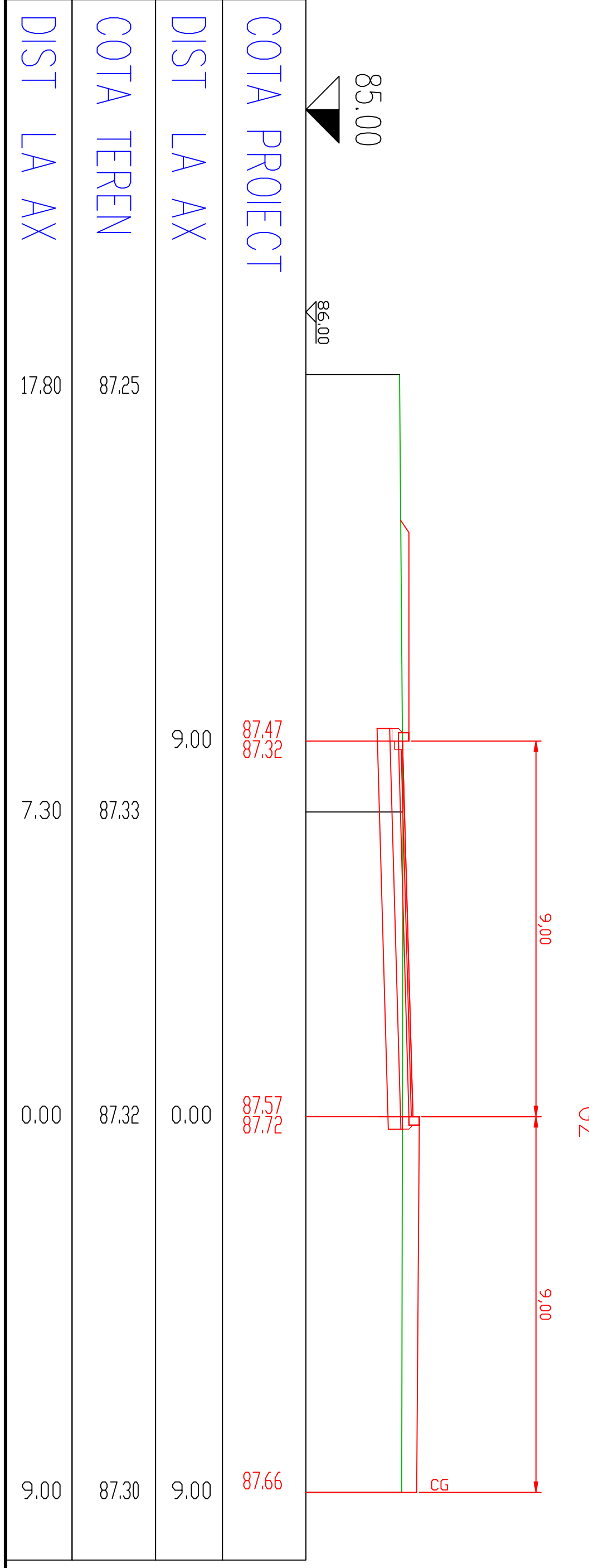
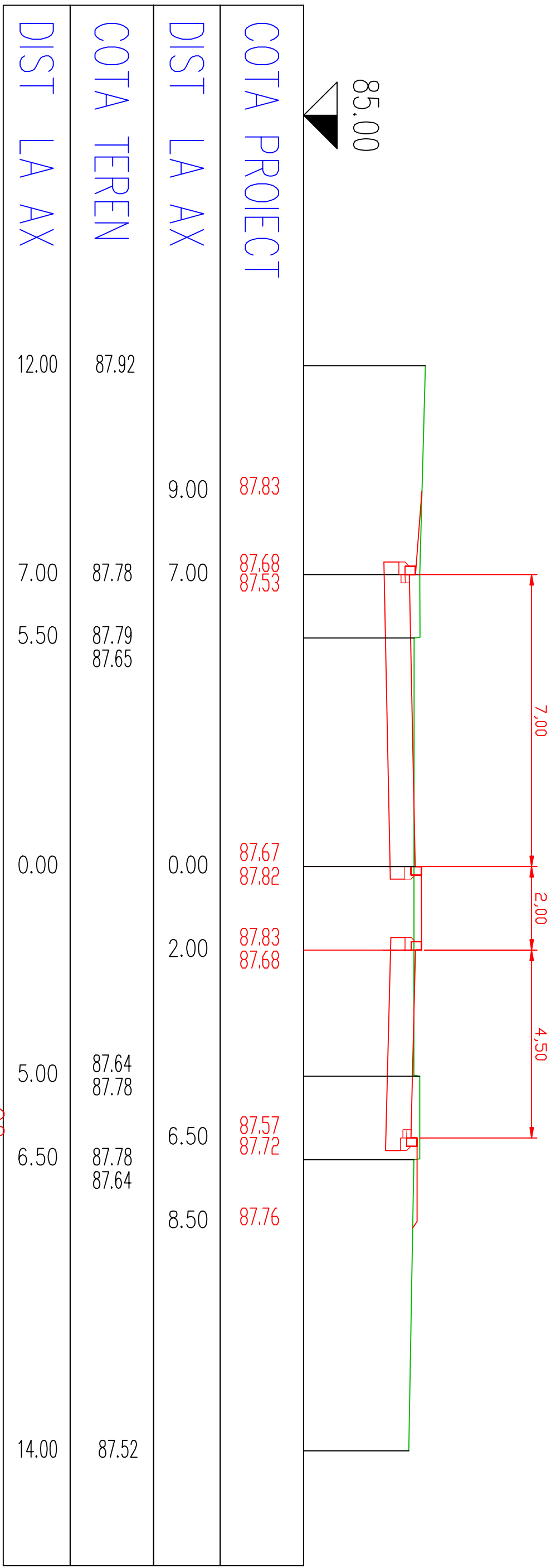

SECTIUNEA 2 G3 - G4

84.00

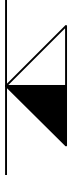

COTA PROIECT	14.00	87.02	87.22 87.07	9.00	87.33 87.48	9.00	87.66
DIST LA AX	14.00			9.00			9.00
COTA TEREN	17.20	86.74			87.10		87.30
DIST LA AX	17.20		8.70		0.00		9.00

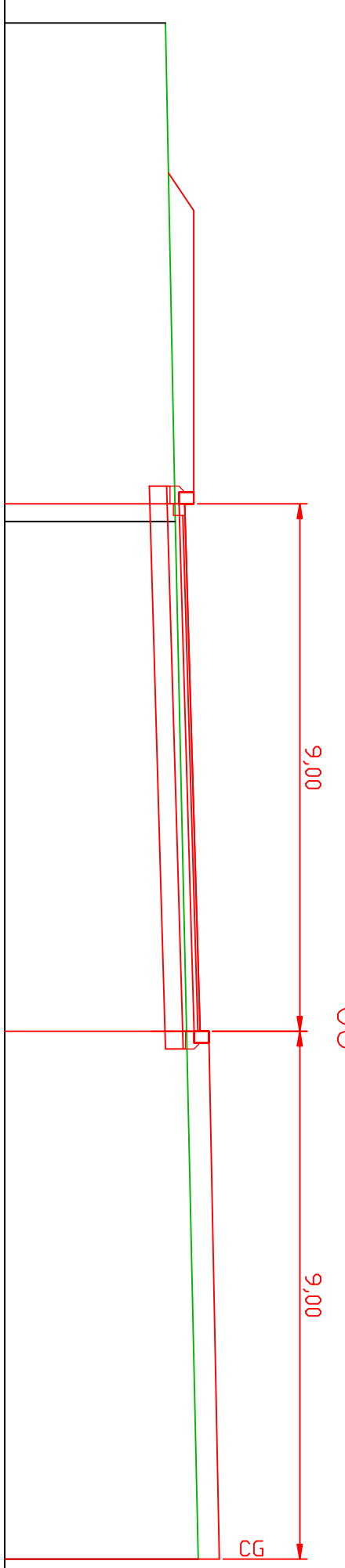

85.00

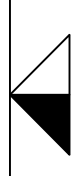

COTA PROIECT	9.00	87.54 87.39	9.00	87.61 87.76	9.00	87.66
DIST LA AX	9.00		9.00		9.00	
COTA TEREN	12.30	87.41 87.30		87.20 87.32		87.30
DIST LA AX	12.30		4.45		0.00	9.00
DIST LA AX	19.90					9.00

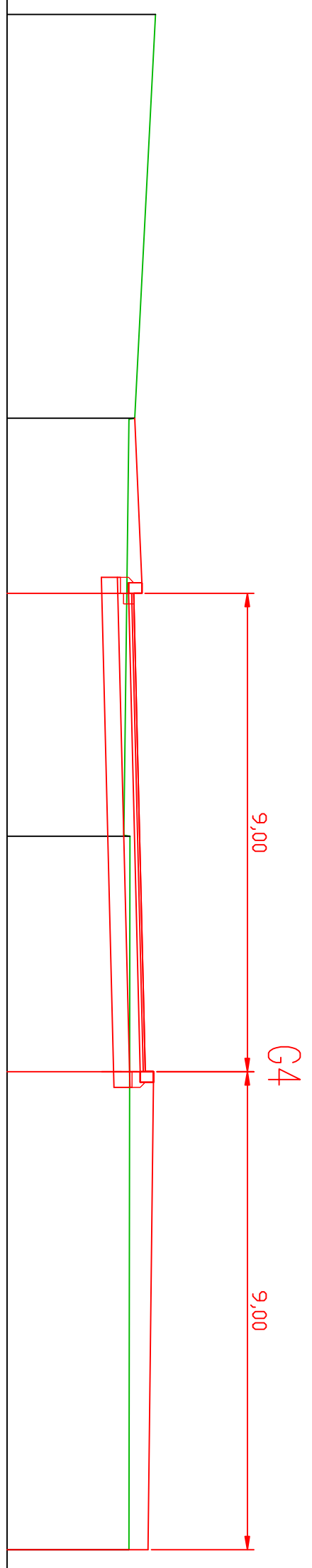

SECTIUNEA 3 P1-P2

84.00

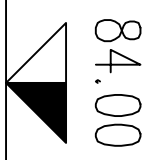
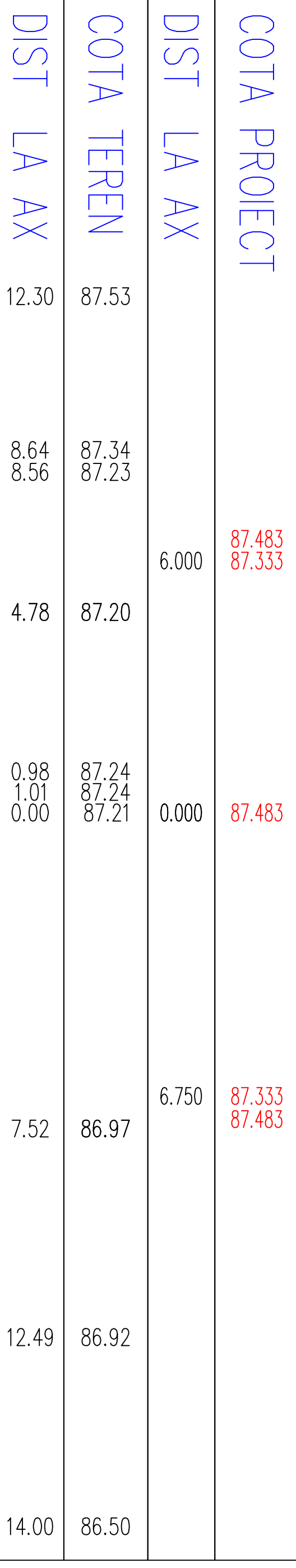
84.00

84.00

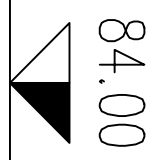
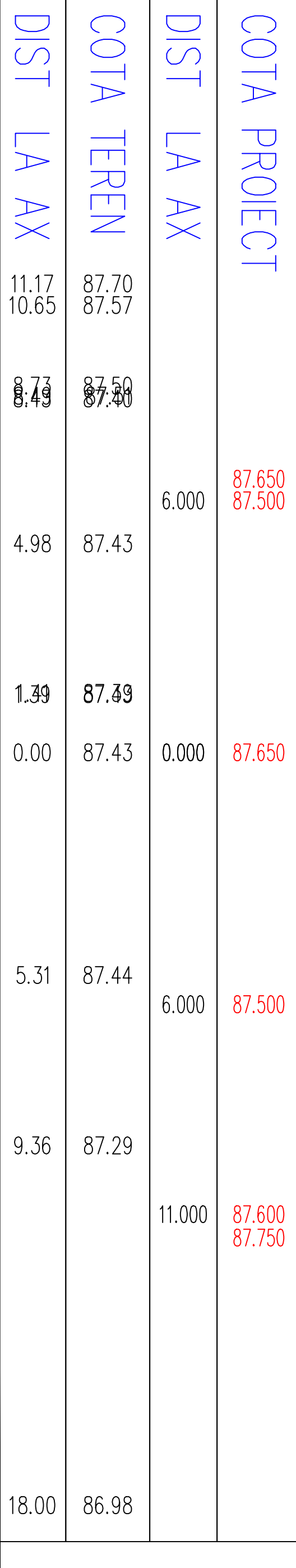

SECTIONEA 4 P3-P4

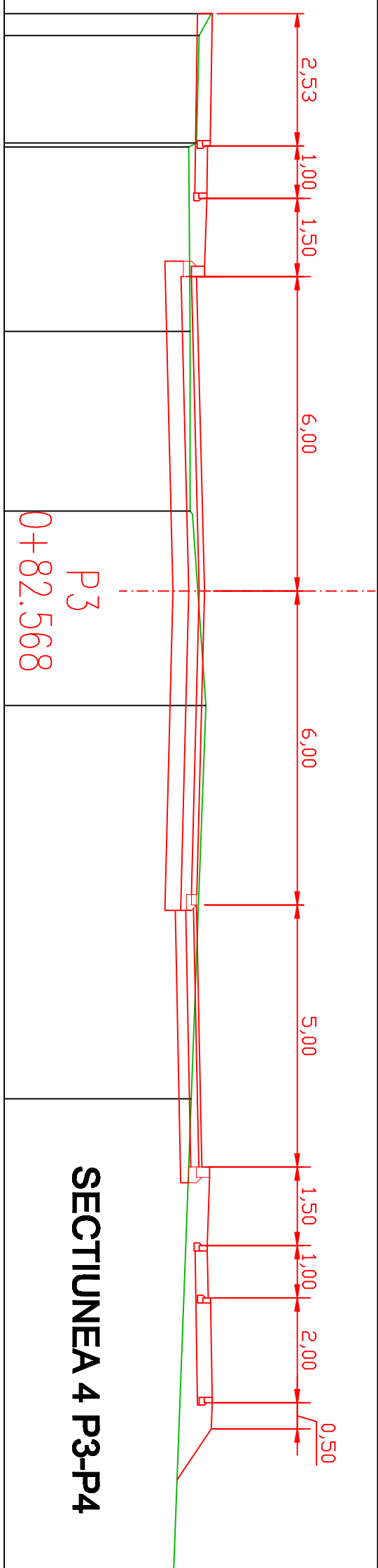
COITA PROIECT

DIST LA AX

COITA TEREN

DIST LA AX

11.03	87.95
10.61	87.72
8.56	87.67
8.48	87.52
4.96	87.55
1.47	87.59
0.00	87.69
2.18	87.85
9.70	87.57
18.73	87.23

84.00

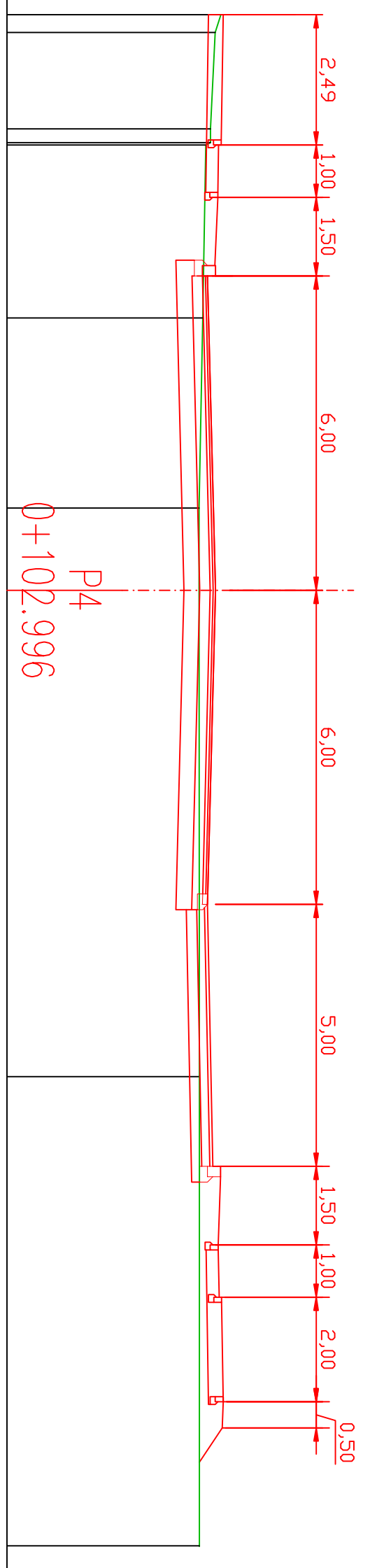

COITA PROIECT

DIST LA AX

COITA TEREN

DIST LA AX

10.99	88.09
10.65	87.98
8.81	87.89
8.50	87.80
5.20	87.74
1.57	87.67
0.00	87.67
9.29	87.68
18.25	87.68

SECTIUNEA 5 P5-P6

84.00

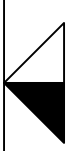

COTA PROIECT	88.290 88.140
DIST LA AX	11.000
COTA TEREN	88.68
DIST LA AX	18.40
COTA PROIECT	88.47
DIST LA AX	13.39
COTA TEREN	88.04 87.94
DIST LA AX	8.93 8.80
COTA PROIECT	87.96
DIST LA AX	5.37
COTA TEREN	87.85 87.91
DIST LA AX	1.80 1.75
COTA PROIECT	87.89
DIST LA AX	0.00
COTA TEREN	87.84
DIST LA AX	4.07
COTA PROIECT	88.040 88.190
DIST LA AX	6.000
COTA TEREN	87.81
DIST LA AX	11.02

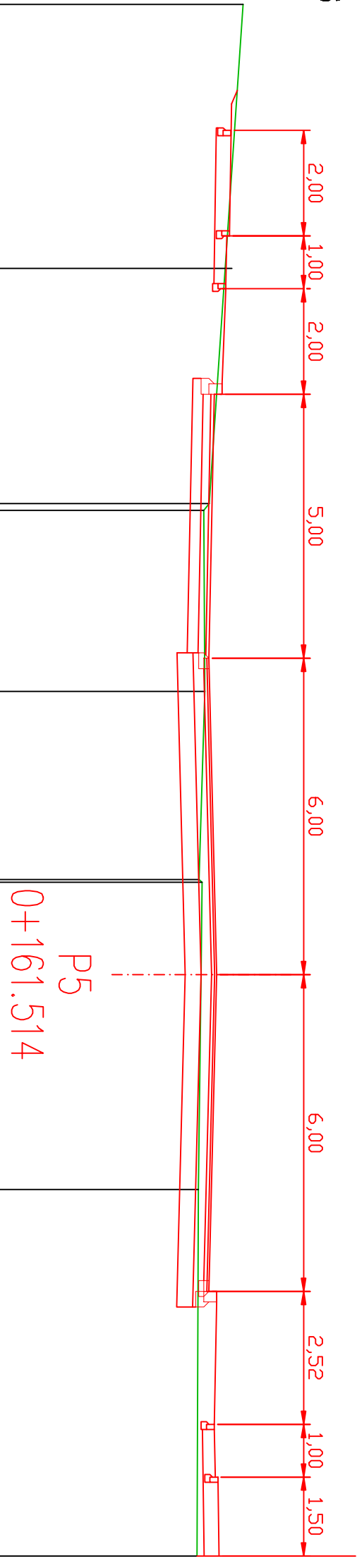

84.00



COTA PROIECT	88.184 88.034
DIST LA AX	11.000
COTA TEREN	88.23
DIST LA AX	18.48
COTA PROIECT	87.934
DIST LA AX	6.62 6.58
COTA TEREN	87.92 87.83
DIST LA AX	3.04
COTA PROIECT	87.83
DIST LA AX	0.00
COTA TEREN	87.82 87.82 87.88
DIST LA AX	0.00 0.32 0.37
COTA PROIECT	87.934
DIST LA AX	6.000
COTA TEREN	87.88
DIST LA AX	6.46
COTA PROIECT	88.034 88.184
DIST LA AX	10.850
COTA TEREN	87.81
DIST LA AX	13.35

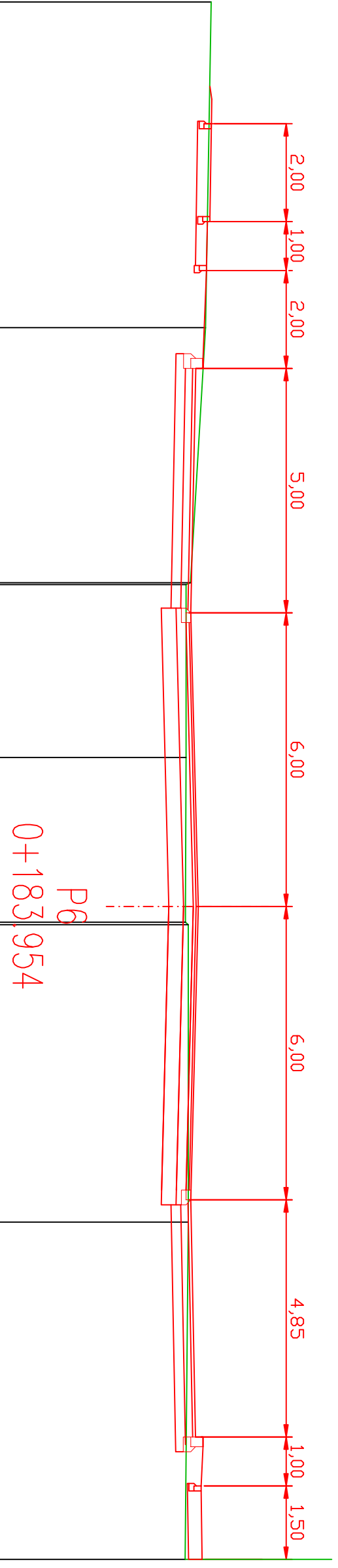

SECTIUNEA 6 P7-P8

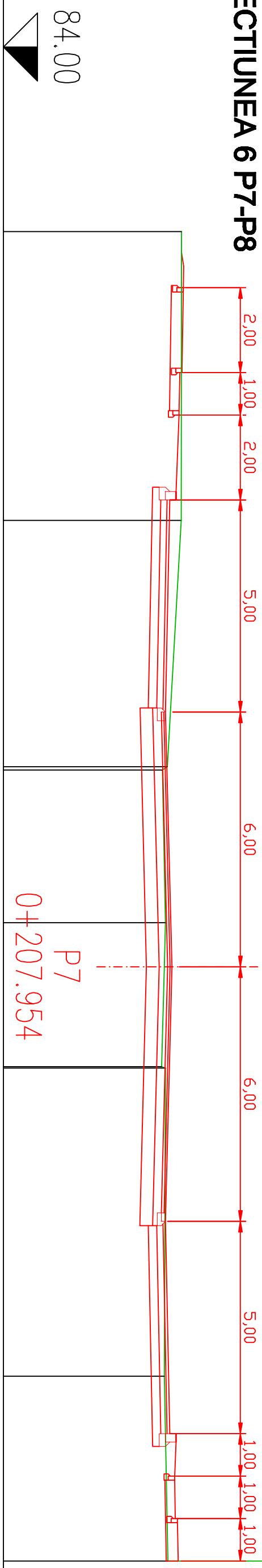

COȚA PROIECT

DIST LA AX

COȚA TEREN

DIST LA AX

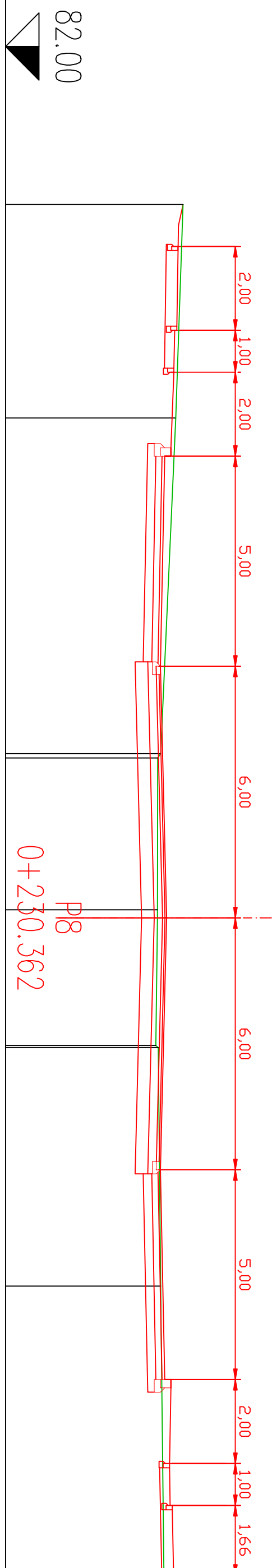

COȚA PROIECT

DIST LA AX

COȚA TEREN

DIST LA AX

84.00	88.070	87.920	87.820	87.970	87.820	87.920	88.070
82.00	87.940	87.790	87.690	87.840	87.690	87.790	87.940
88.19	88.19	88.19	87.86	87.82	87.79	87.73	87.82
88.19	88.19	88.19	87.75	87.79	87.79	87.82	87.79
87.32	10.52	4.71	1.04	0.00	2.36	9.65	14.00
17.32	11.000	4.64	0.00	0.00	2.39	11.000	14.00
11.91	6.000	6.000	6.000	6.000	6.000	11.000	14.00
11.000	6.000	6.000	6.000	6.000	6.000	11.000	14.00
88.23	88.06	87.70	87.62	87.58	87.70	87.70	87.80
88.23	88.06	87.63	87.62	87.64	87.70	87.70	87.80
17.00	11.91	3.91	0.00	3.04	8.77	15.66	15.66
17.00	11.91	3.81	0.00	3.09	8.77	15.66	15.66

SECTIUNEA 8 P11-P12

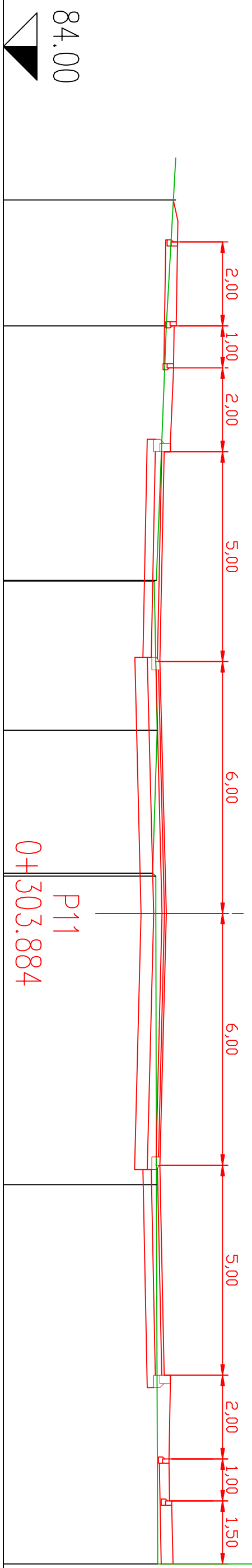

87.982

COTA PROIECT

DIST LA AX

COTA TEREN

DIST LA AX

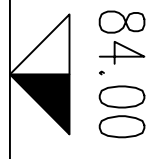

COTA PROIECT

DIST LA AX

COTA TEREN

DIST LA AX

P11
0+303.884

P12
0+321.680

87.982
87.840

87.740

87.882

87.740

87.840
87.982

88.028
87.878

87.778

87.928

87.778

87.878
88.028

17.00	88.11
14.00	87.89
7.94	87.65
7.92	87.60
4.36	87.67
0.96	87.56
0.89	87.64
0.00	87.64
6.46	87.65
15.50	87.69

17.00	87.99
14.00	87.84
8.97	87.69
8.91	87.62
8.58	87.59
5.35	87.67
2.60	87.57
2.02	87.64
1.99	87.72
0.00	87.73
5.71	87.77
14.00	87.79

SECTIUNEA 9 P13-P14

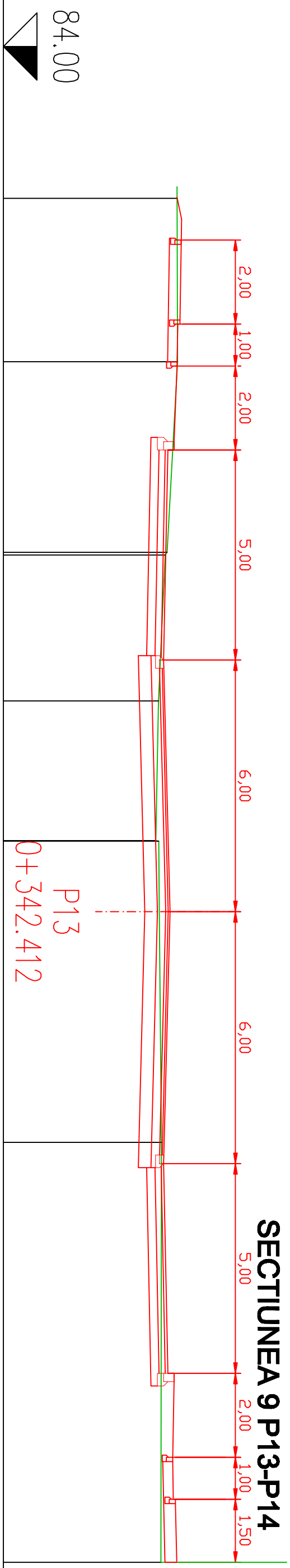

COȚA PROIECT

DIST LA AX

COȚA TEREN

DIST LA AX

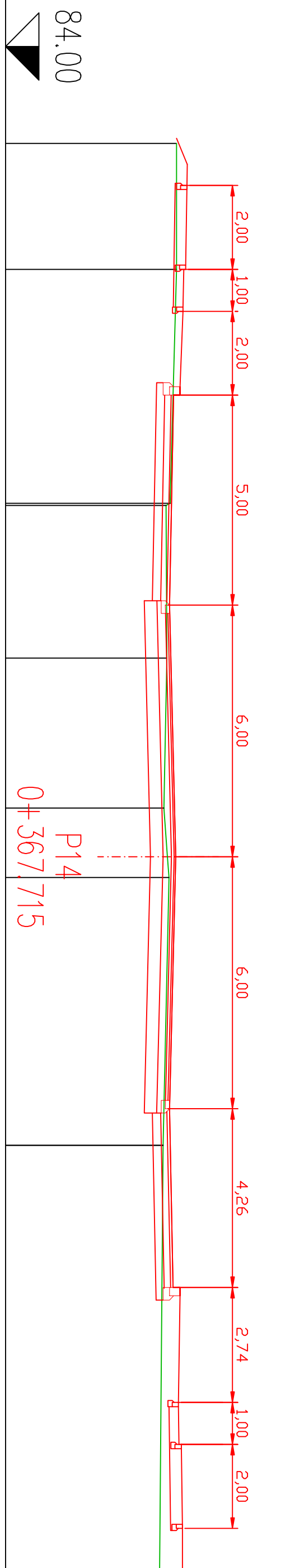

COȚA PROIECT

DIST LA AX

COȚA TEREN

DIST LA AX

18.00 14.00

8.42 8.37

4.74

1.17

0.00 0.49

6.87

17.01

88.10 88.08

87.93 87.83

87.85

87.78

87.87 87.90

87.76

87.68

11.000

6.000

0.000

6.000

11.000

88.157
88.030

87.930

88.057

87.930

88.030
88.157

0+367.715
P14

0+342.412
P13

2,00

1,00

2,00

5,00

6,00

6,00

4,26

2,74

1,00

2,00

2,00

1,00

2,00

5,00

6,00

6,00

6,00

5,00

2,00

1,00

1,50

84.00

13.11

8.56 8.50

5.02

1.68 1.70

0.00

5.50

15.50

88.16

87.91 87.86

87.70

87.64 87.71

87.72

87.77

87.76

88.080
87.970

87.870

87.980

87.870

87.970
88.080

11.000

6.000

0.000

6.000

11.000

SECTIUNEA 10 P15-P16

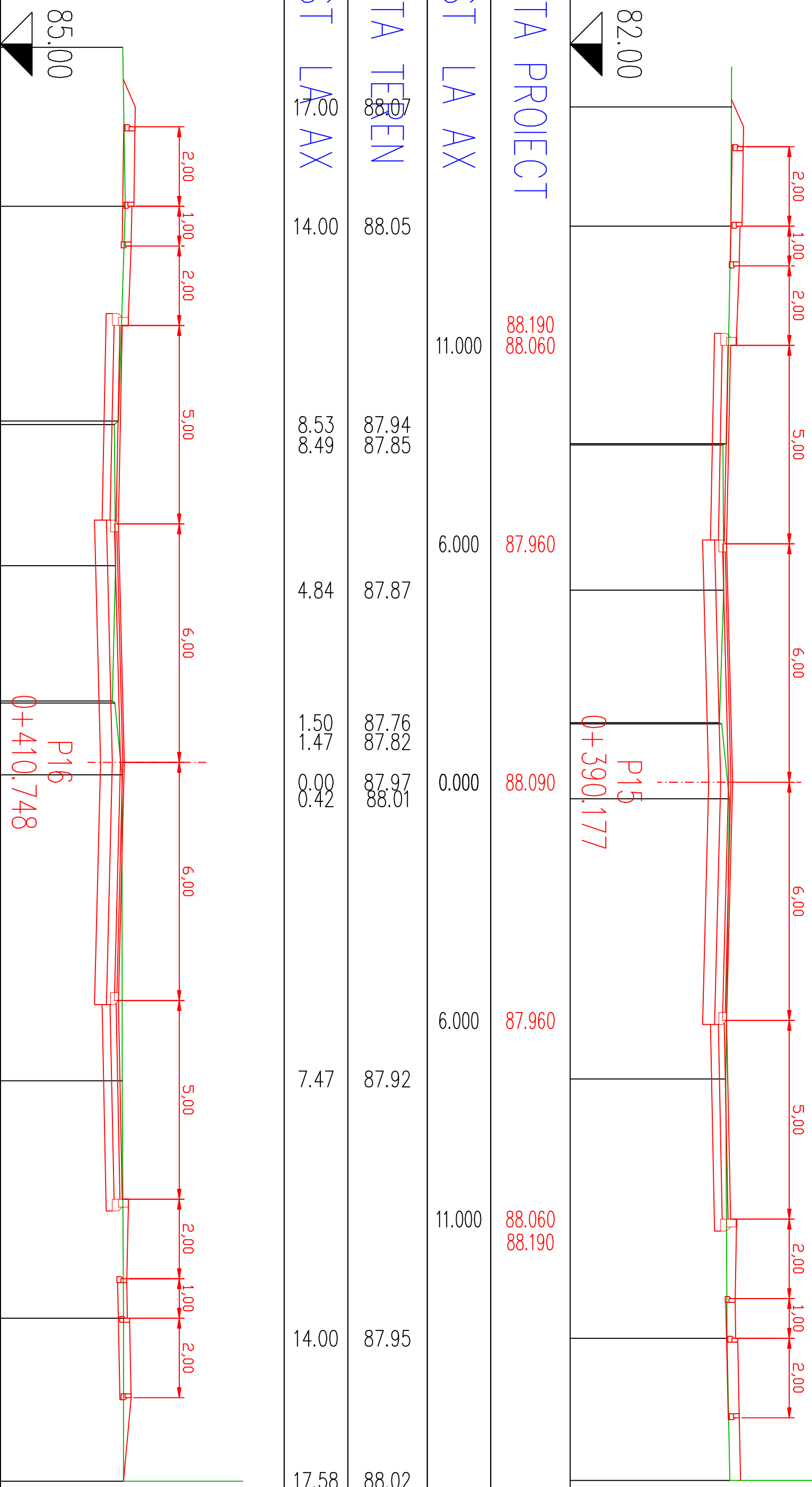

COȚA PROIECT

DIST LA AX

COȚA TEREN

DIST LA AX

COȚA PROIECT

DIST LA AX

COȚA TEREN

DIST LA AX

88.190
88.060

11.000

88.07
88.05

17.00
14.00

88.220
88.070

11.000

88.08
88.15

18.00
14.00

87.960

6.000

87.94
87.85

8.53
8.49

87.970

6.000

87.97
87.87

8.59
8.50

88.090

0.000

87.76
87.82
87.97
88.01

1.50
1.47
0.00
0.42

88.120

0.000

87.82
87.88

1.54
1.49

87.960

6.000

87.92

7.47

87.970

6.000

88.07

8.02

88.060
88.190

11.000

87.95

14.00

88.070
88.220

11.000

88.10

14.00

88.07

18.10

88.02

17.58

SECTIUNEA 11 P17-P18

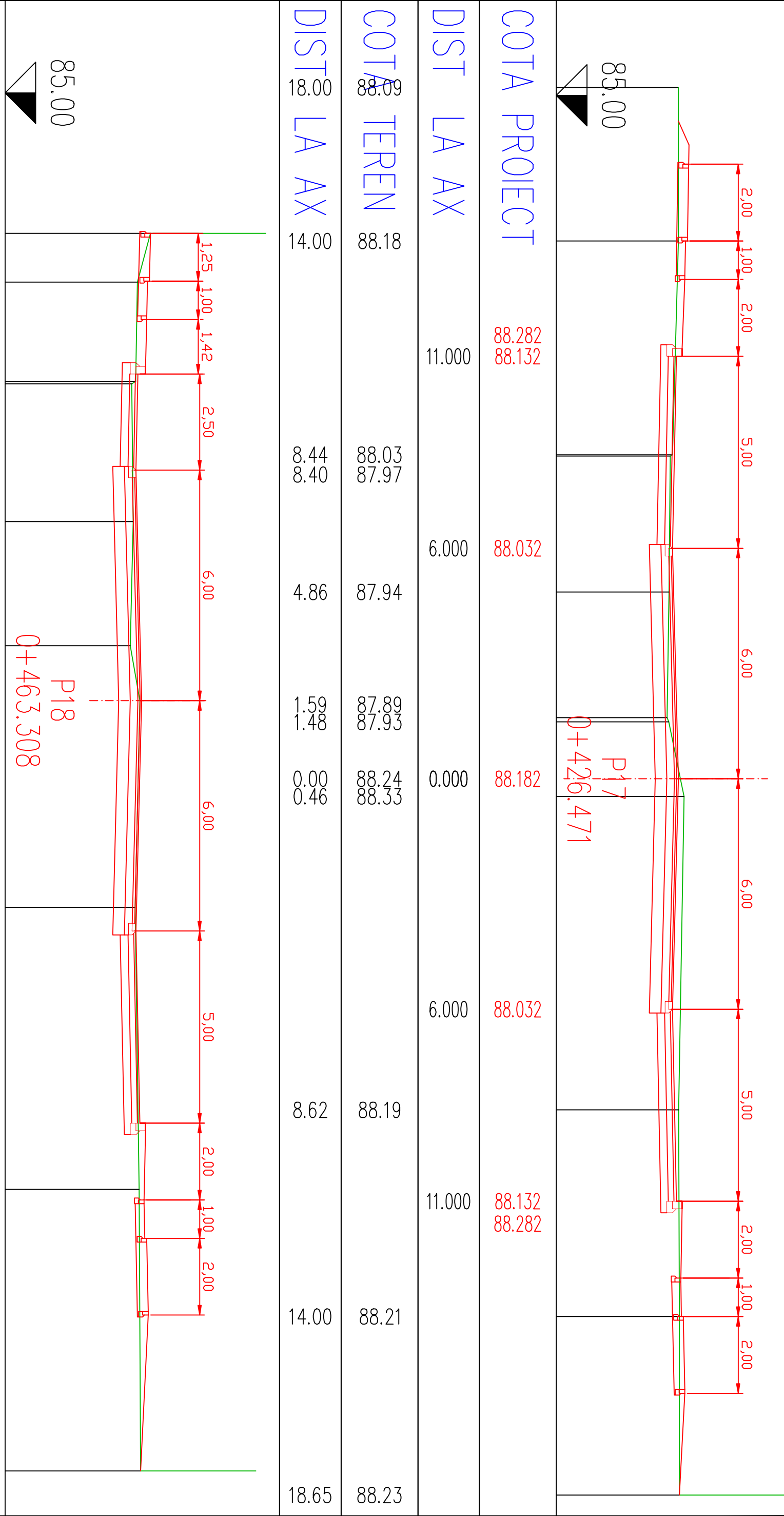

COȚA TEREN	COȚA PROIECT	DIST LA AX	COȚA TEREN	COȚA PROIECT	DIST LA AX
88.79	88.610	12.17	88.40	88.510	12.73
88.45	88.460	10.90	88.30	88.660	12.06
8.31	88.410	8.25	88.34	88.510	8.62
8.25	88.560	8.25	88.26	88.660	8.62
4.66	88.410	4.66	88.51	88.510	14.00
1.43	88.560	1.43	88.26	88.660	14.00
0.00	88.410	0.00	88.51	88.510	18.65
5.38	88.410	5.38	88.39	88.660	18.65
12.73	88.510	12.73	88.49	88.510	18.65
20.06	88.660	20.06	88.53	88.660	18.65

SECTIUNEA 12 P19-P20

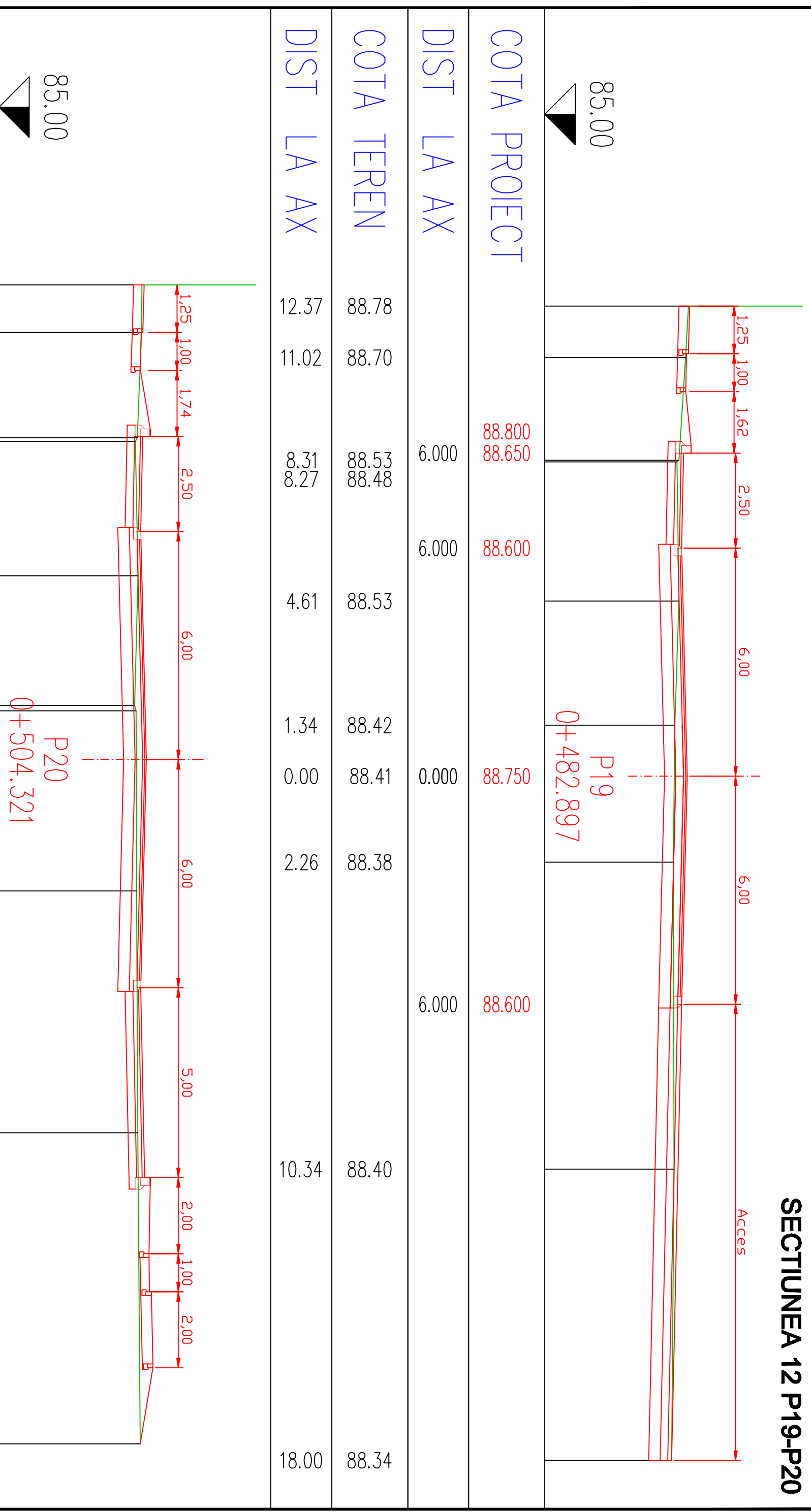

COPIA PROIECT	COPIA TEREN	DIST LA AX	DIST LA AX
88.930 88.780	88.76 88.75	12.49 11.24	12.49 11.24
88.730	88.64 88.59	8.47 8.38	8.47 8.38
88.730	88.66	4.84	4.84
88.880	88.57 88.61	1.43 1.29	1.43 1.29
88.730	88.61	0.00	0.00
88.730	88.62	3.46	3.46
88.830 88.980	88.65	9.82	9.82
	88.72	18.00	18.00

SECTIUNEA 13 P21-P22

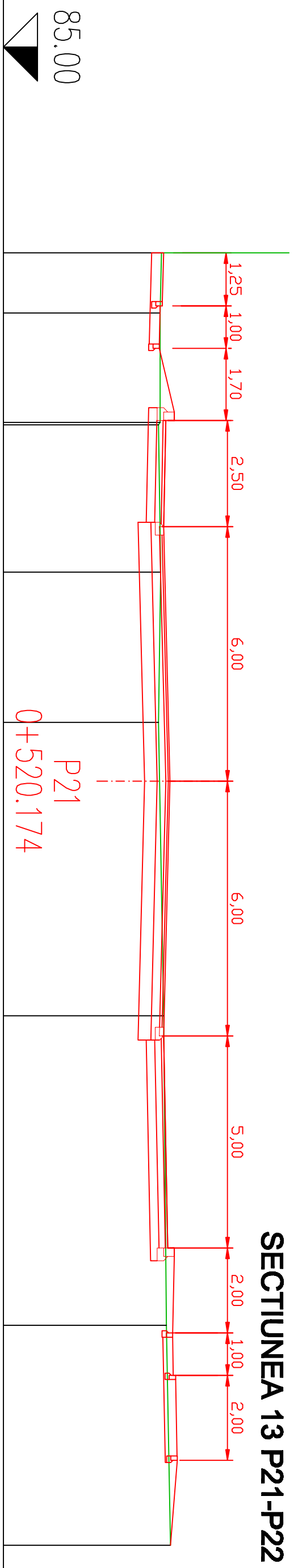

COȚA PROIECT

DIST LA AX

COȚA TEREN

DIST LA AX

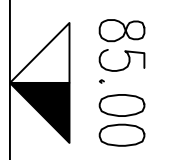

COȚA PROIECT

DIST LA AX

COȚA TEREN

DIST LA AX

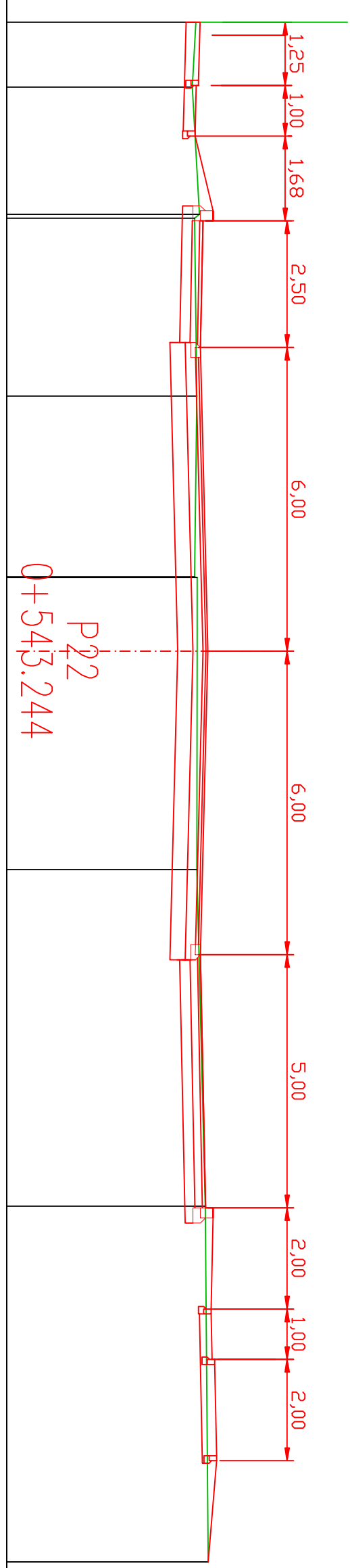

88.970
88.780

88.780

88.920

88.780

88.780
89.020

12.45	88.72		
11.04	88.69		
8.45	88.69	6.000	
8.40	88.65		
4.93	88.70	6.000	
1.39	88.65		
0.00	88.67	0.000	
5.53	88.77	6.000	
12.82	88.84		
14.00	88.93		

89.028
88.890

88.840

88.978

88.840

88.940
89.078

12.43	88.74		
11.14	88.67		
8.63	88.81	6.000	
8.55	88.72		
5.04	88.76	6.000	
1.47	88.72		
1.45	88.77		
0.00	88.77	0.000	
4.32	88.76	6.000	
10.97	88.93	11.000	
18.00	88.99		

SECTIUNEA 14 P23-P24

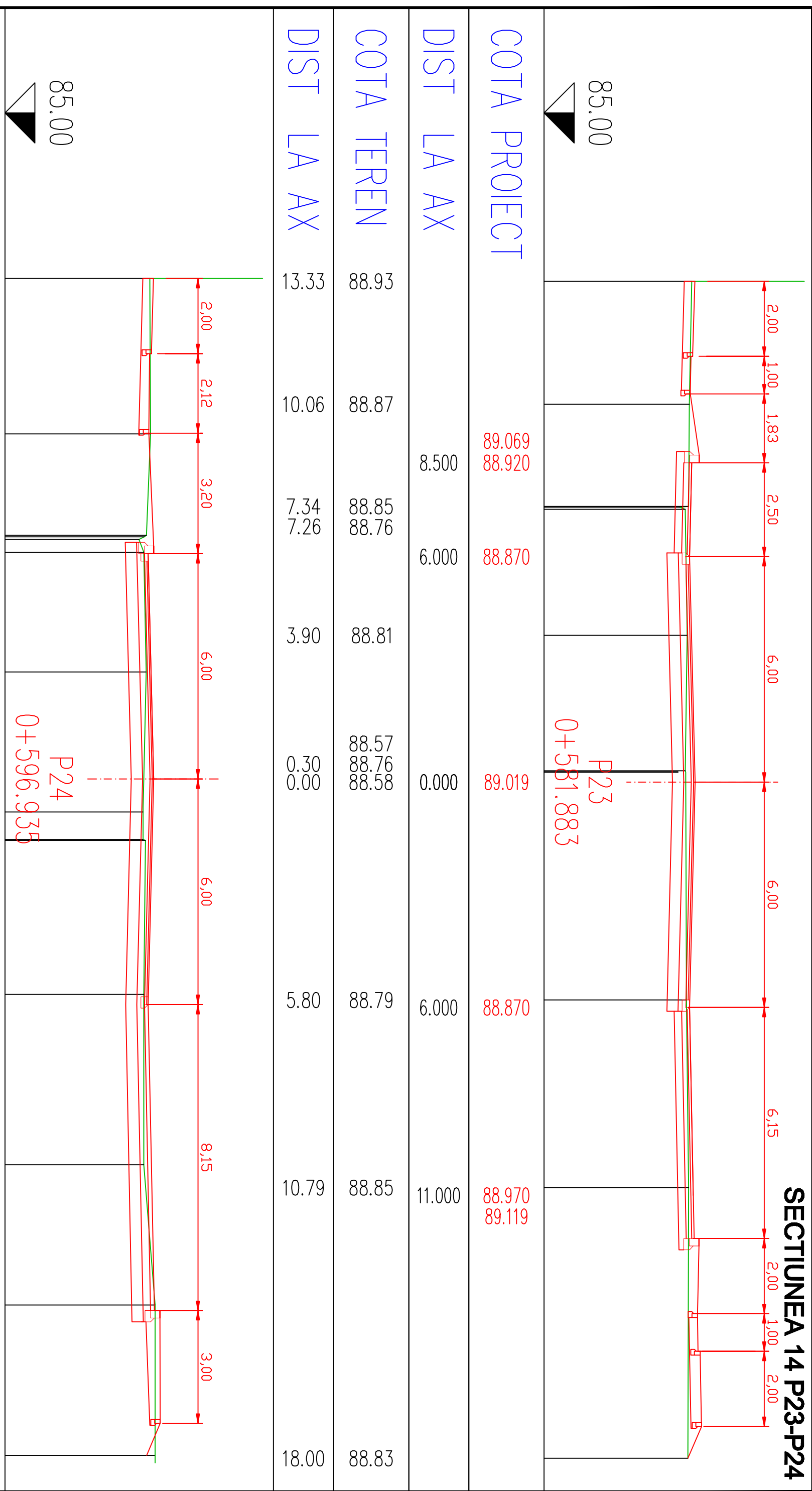

85.00

COȚA PROIECT

DIST LA AX

COȚA TEREN

DIST LA AX

85.00

COȚA PROIECT

DIST LA AX

COȚA TEREN

DIST LA AX

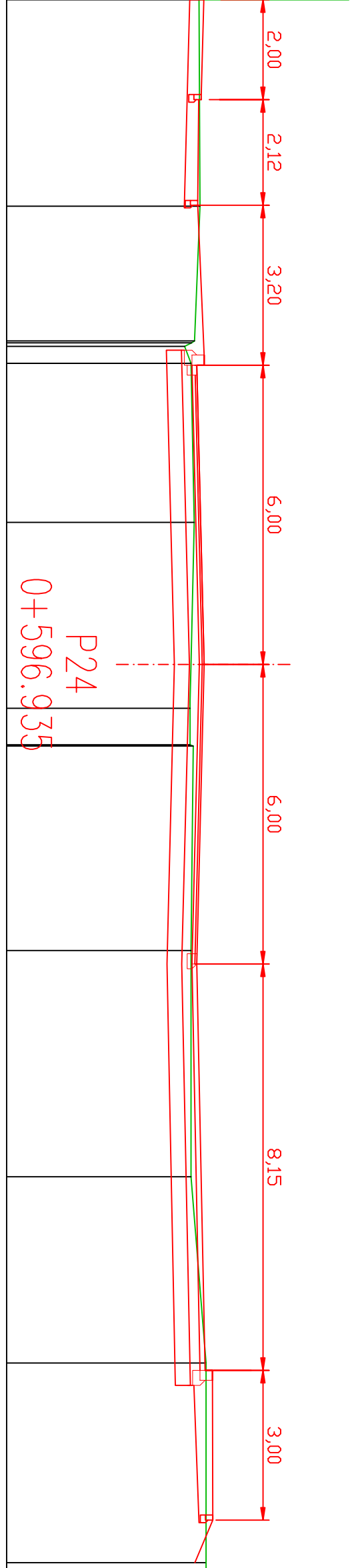
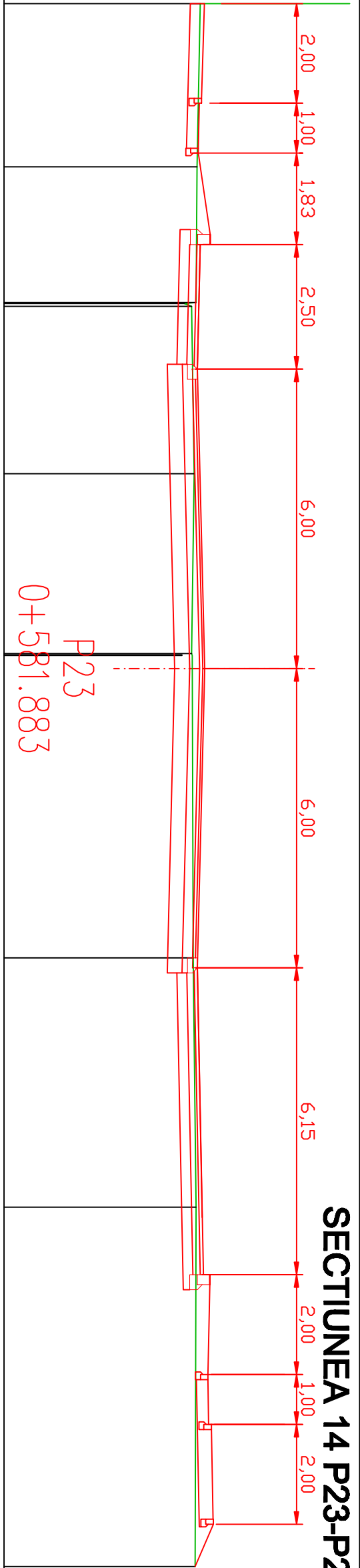

89.069
88.920

88.870

89.019

88.870

88.970
89.119

89.060
88.810

88.960

88.810

0+596.935
P24

0+581.883
P23

SECTIUNEA 15 P25-P26

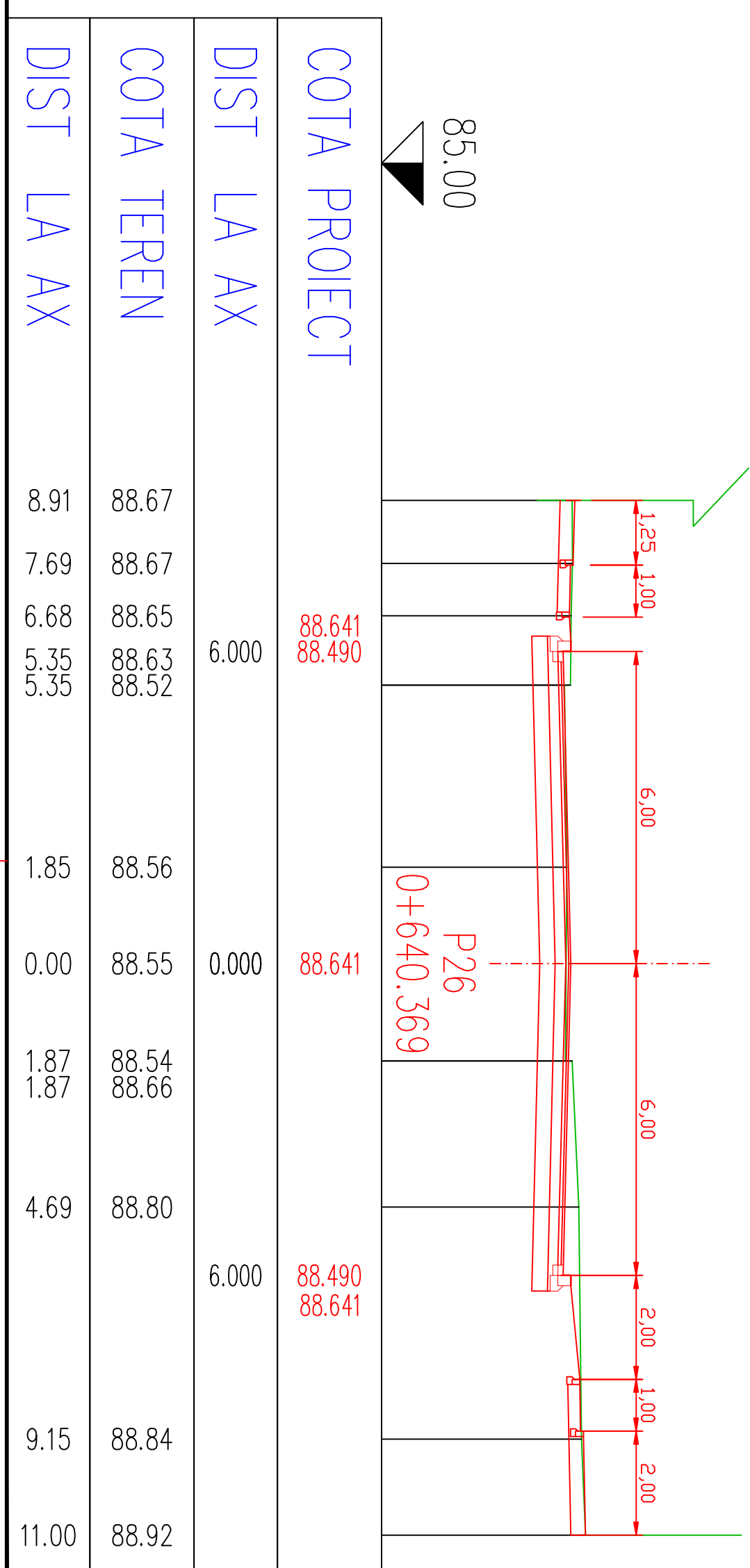
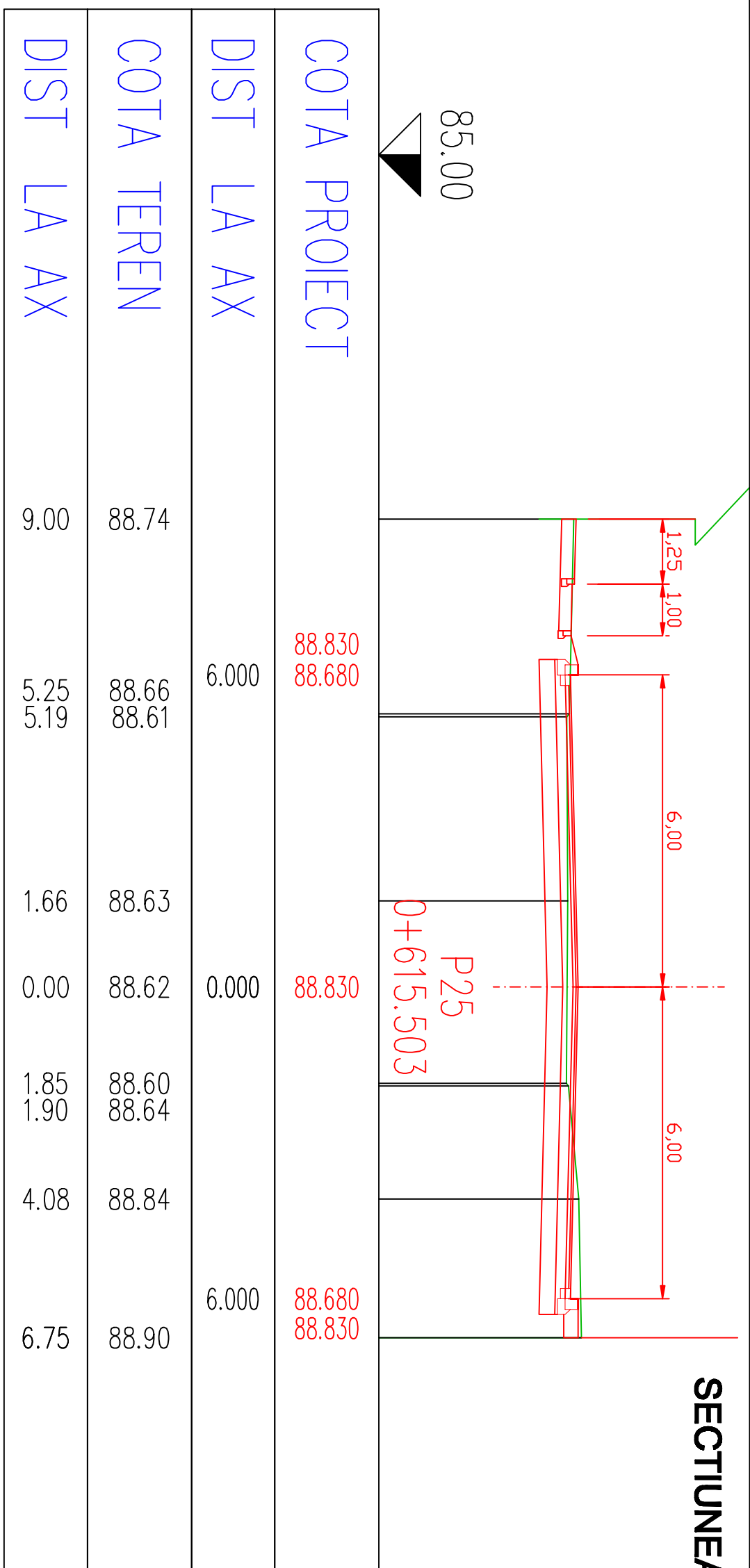

SECTIUNEA 16 P27-P28

85.00

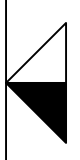
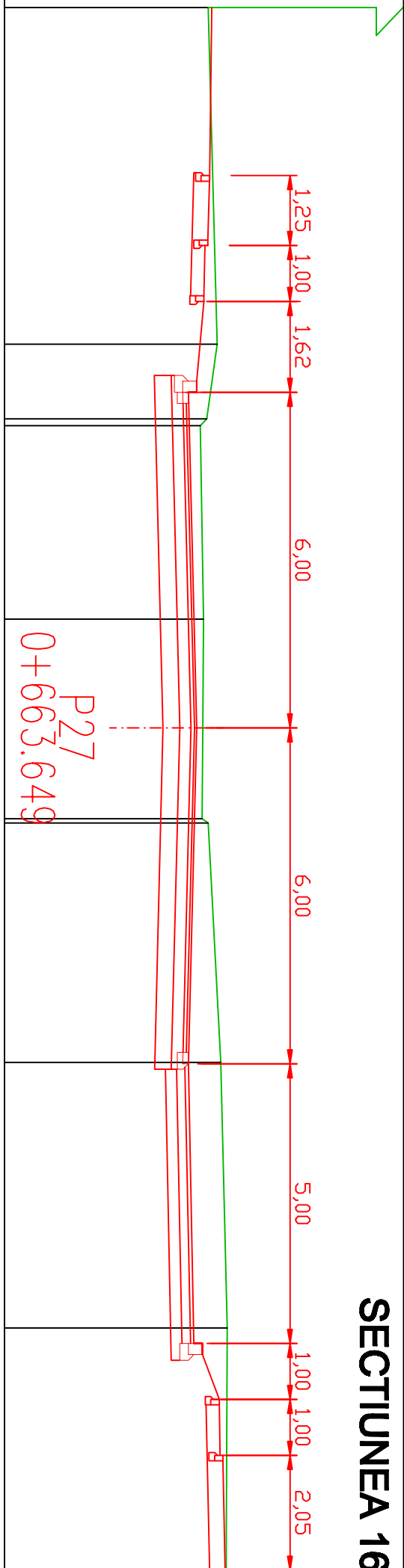
COȚA PROIECT

DIST LA AX

COȚA TEREN

DIST LA AX

88.433
88.280
88.433
88.280
88.380
88.533

12.87	88.70	6.86	88.80	5.52	88.62	1.95	88.55	0.00	88.54	1.62	88.53	5.98	88.86	10.72	88.98	15.05	88.96
				5.40	88.50					1.70	88.64						

85.00

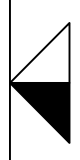
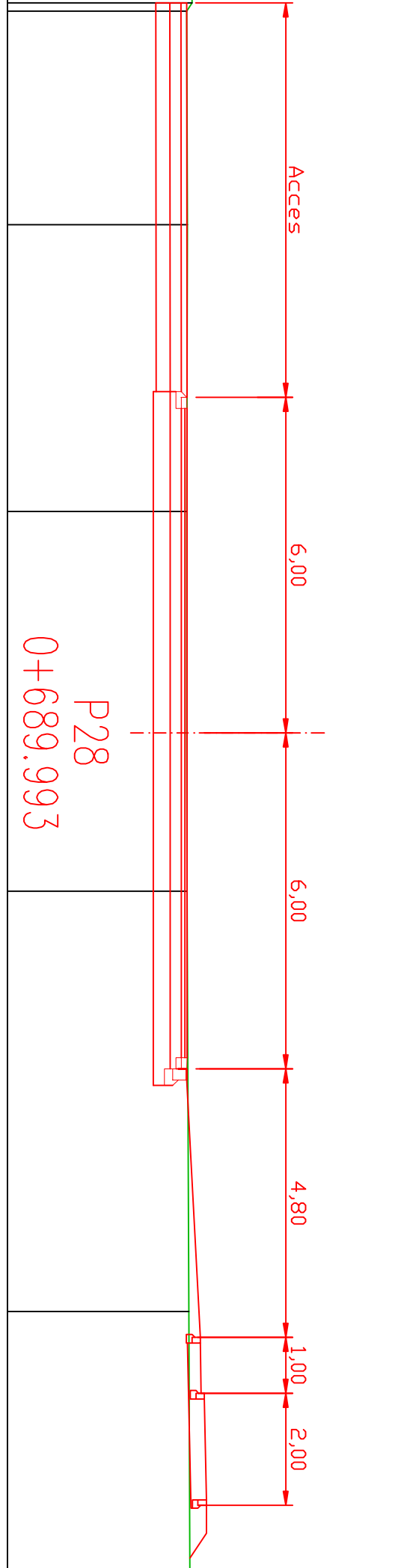
COȚA PROIECT

DIST LA AX

COȚA TEREN

DIST LA AX

88.210
88.210
88.210
88.210

14.00	88.29	13.05	88.30	12.90	88.24	9.08	88.22	6.000	88.210	3.96	88.20	0.00	88.21	0.000	88.210	2.83	88.21	6.000	88.210	10.34	88.24	17.00	88.27
-------	-------	-------	-------	-------	-------	------	-------	-------	--------	------	-------	------	-------	-------	--------	------	-------	-------	--------	-------	-------	-------	-------

SECTIUNEA 17 P29-P30

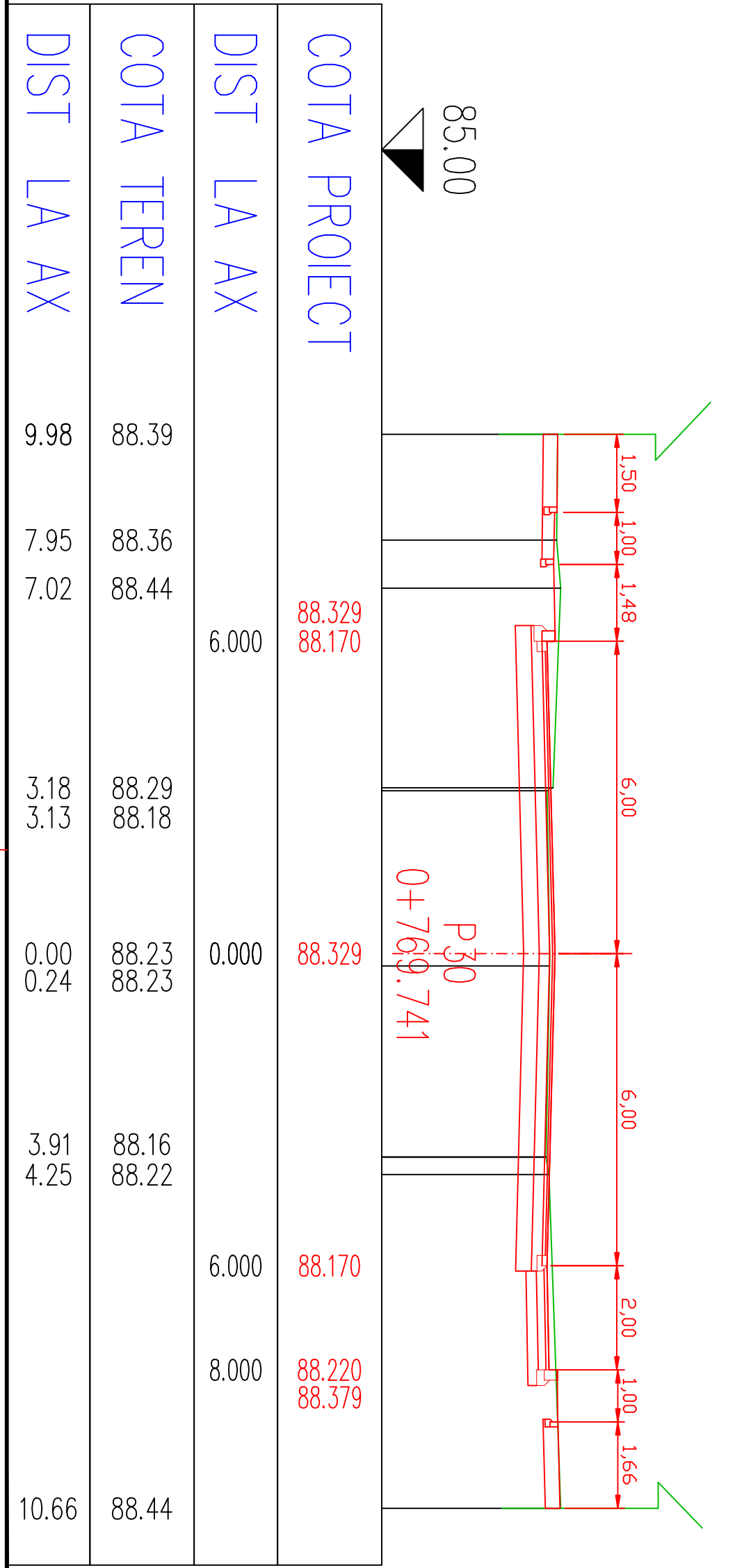
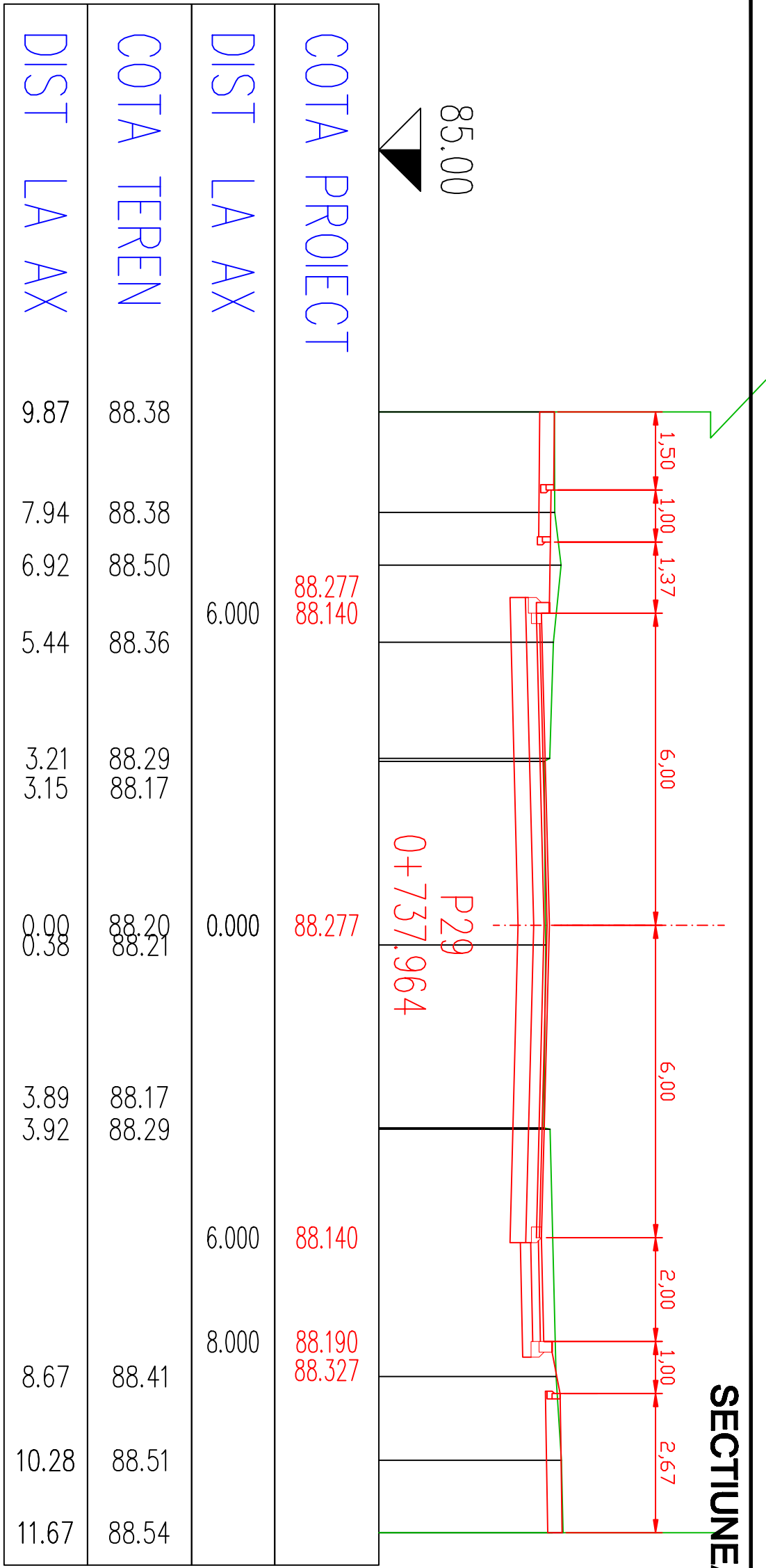

SECTIUNEA 18 P31-P32

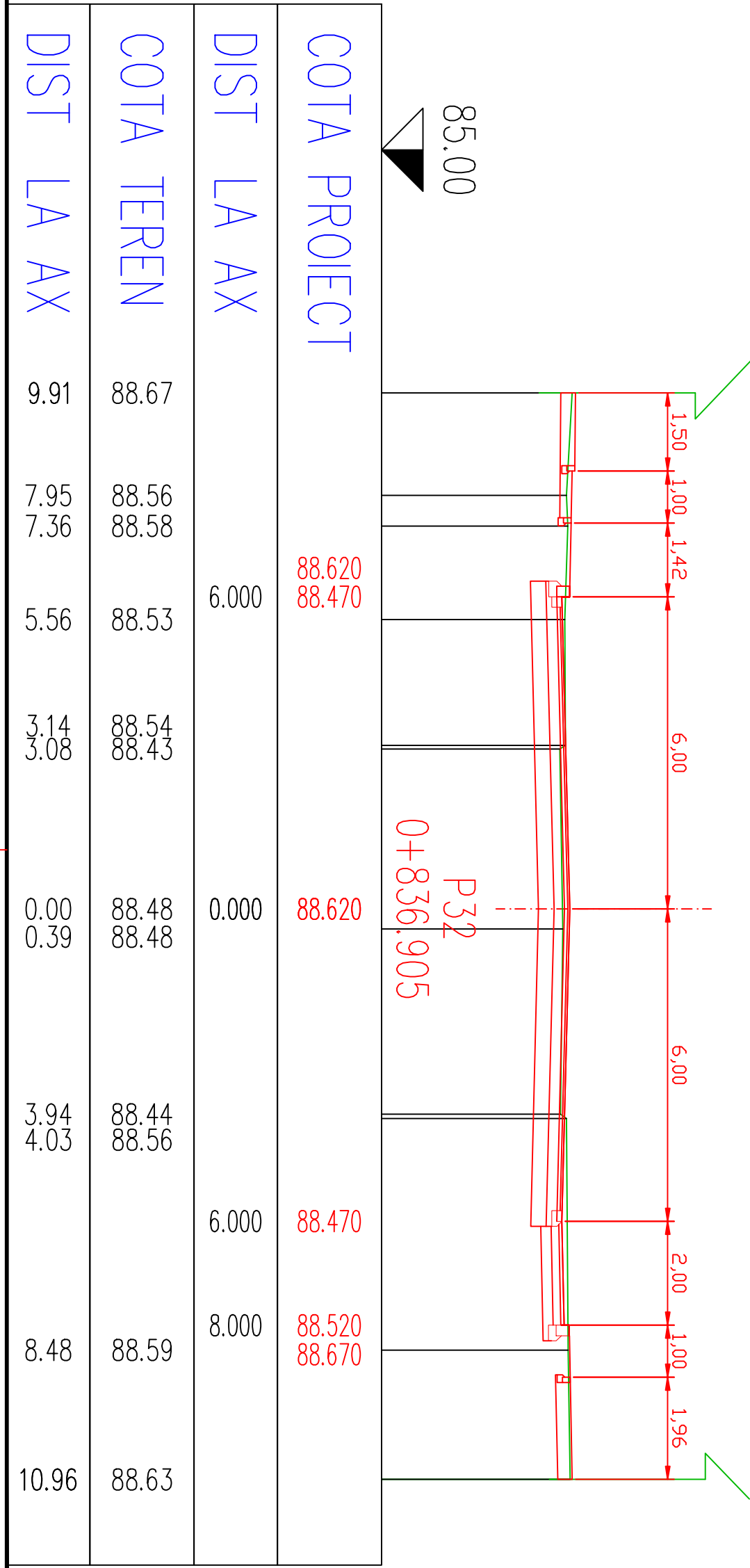
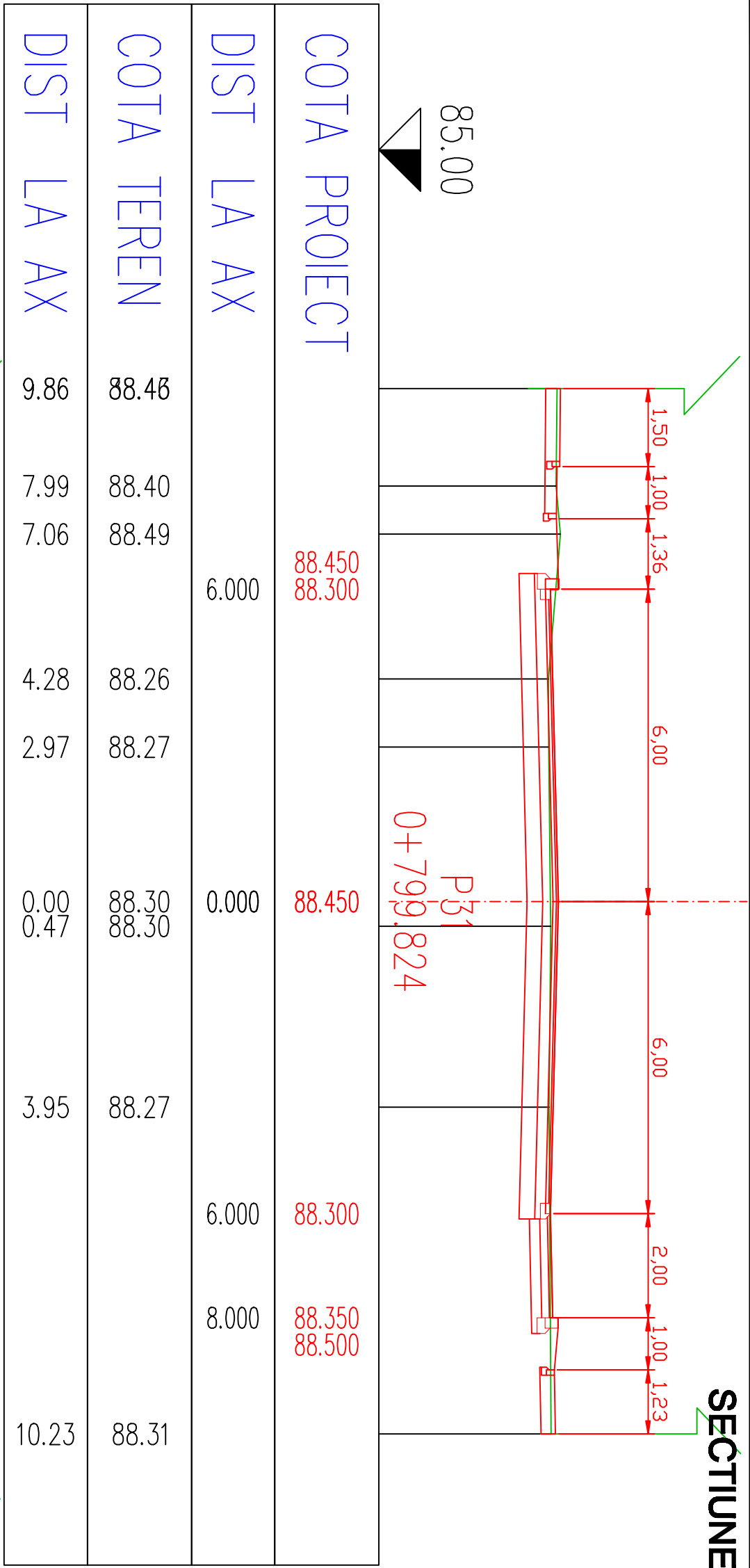

SECTIUNEA 19 P33-P34

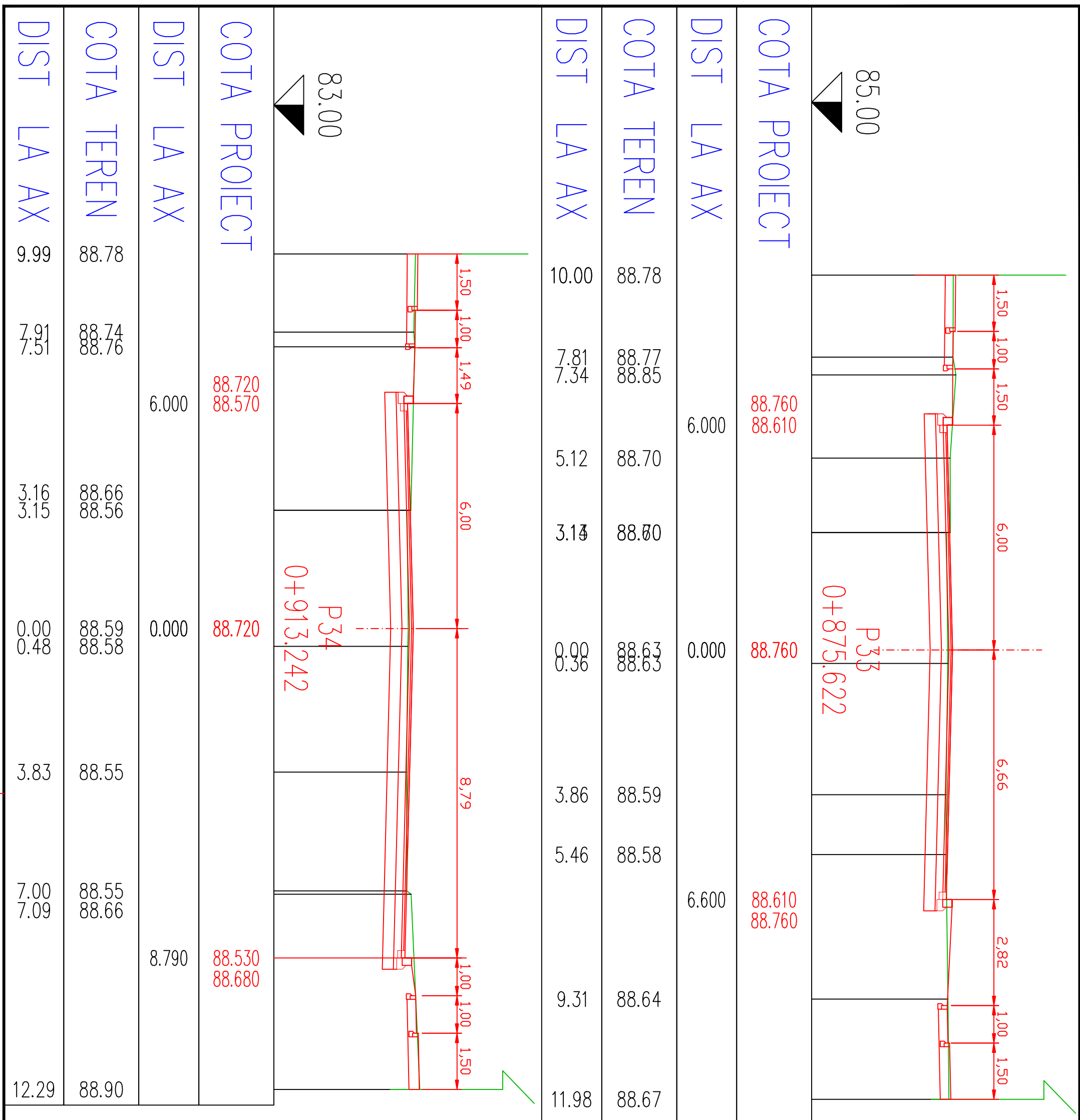

sc PATH'S ROUT SRL
 Tel/fax: 0256-216933, 291052
 300430 TIMISOARA, Str. E.Zola 92
 E-mail: secretariat@pathsrou.ro
 ORC J 35/230/1995, CUI: RO7267049
 Capital social: 640.000 lei



Proiect:
 EXTINDERE LA 4 BENZI STRADA
 PROF. DR. AUREL PAUNESCU-PODEANU
Loc constr: STRADA AUREL PAUNESCU PODEANU
Beneficiar: MUNICIPIUL TIMISOARA

Nr.proiect:
 14.014/1
Faza: P.T.+DE

DIRECTOR	ing. PERCEC VASILE
SEF PROIECT	ing. TOTH CAROL
PROIECTANT	ing. TOTH CAROL

SCARA
 1:100
Data:
 NOV.2014

Obiect: EXTINDERE LA 4 BENZI STRADA PODEANU
Plansa: PROFILURI TRANSVERSALE

Nr.plan
 05D

SE APLICA INTRE KM 0+055 SI KM 0+105

STRADA PODEANU

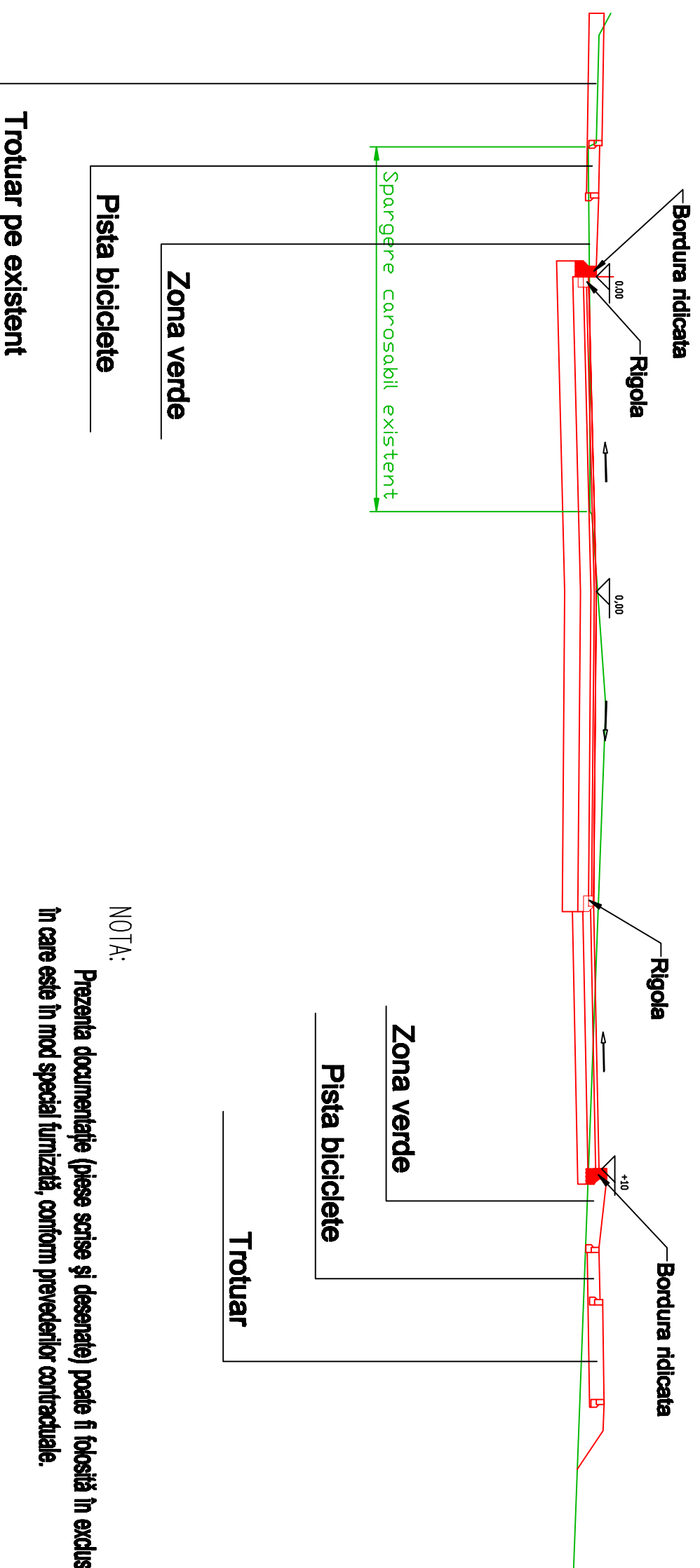
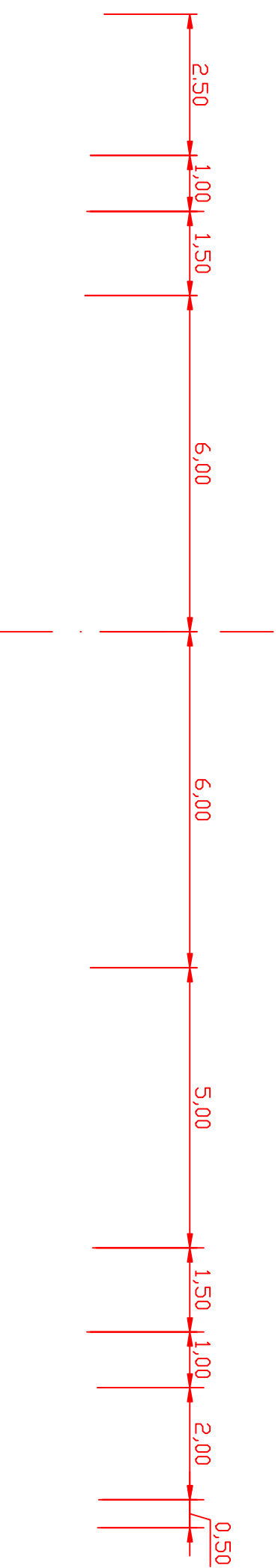

PARCARE



NOTA:

Prezenta documentatie (piese scrise si desenate) poate fi folosita în exclusivitate pentru scopul în care este în mod special furnizata, conform prevederilor contractuale.

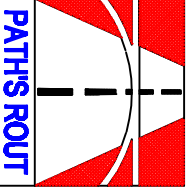
Detaliile de structuri rutiere si de încadrare a acestora sunt prezentate pe planșa nr. 14.014/1 - 04D

			
sc PATHS ROUT SRL Tel/fax: 0256-216833, 291052 300430 TIMISOARA, Str. E.Zde 92 E-mail: secretaria@pathsroutr.ro ORC J 35729/196, CUI: RO7267049 Capital social: 640.000 lei		Proiect: EXTINDERE LA 4 BENZI STRADA PROF.DR. AUREL PAUNESCU-PODEANU Loc constr: STRADA AUREL PAUNESCU-PODEANU Beneficiar: MUNICIPIUL TIMISOARA	
DIRECTOR	Ing. PERCEC VASILE	SCARA	Nr.proiect: 14.014/1
SEF PROIECT	Ing. TOTI CAROL	1:100	Nr.plan
PROIECTANT	Ing. TOTI CAROL	Data: NOV.2014	Faza: P.I.01E
Obiect: EXTINDERE LA 4 BENZI STRADA PODEANU		Nr.plan	
Planșa: PROFIL TRANSVERSAL TIP NR. 1		03D/1	

SE APLICA INTRE KM 0+160 SI KM 0+430

PARCARE

STRADA PODEANU

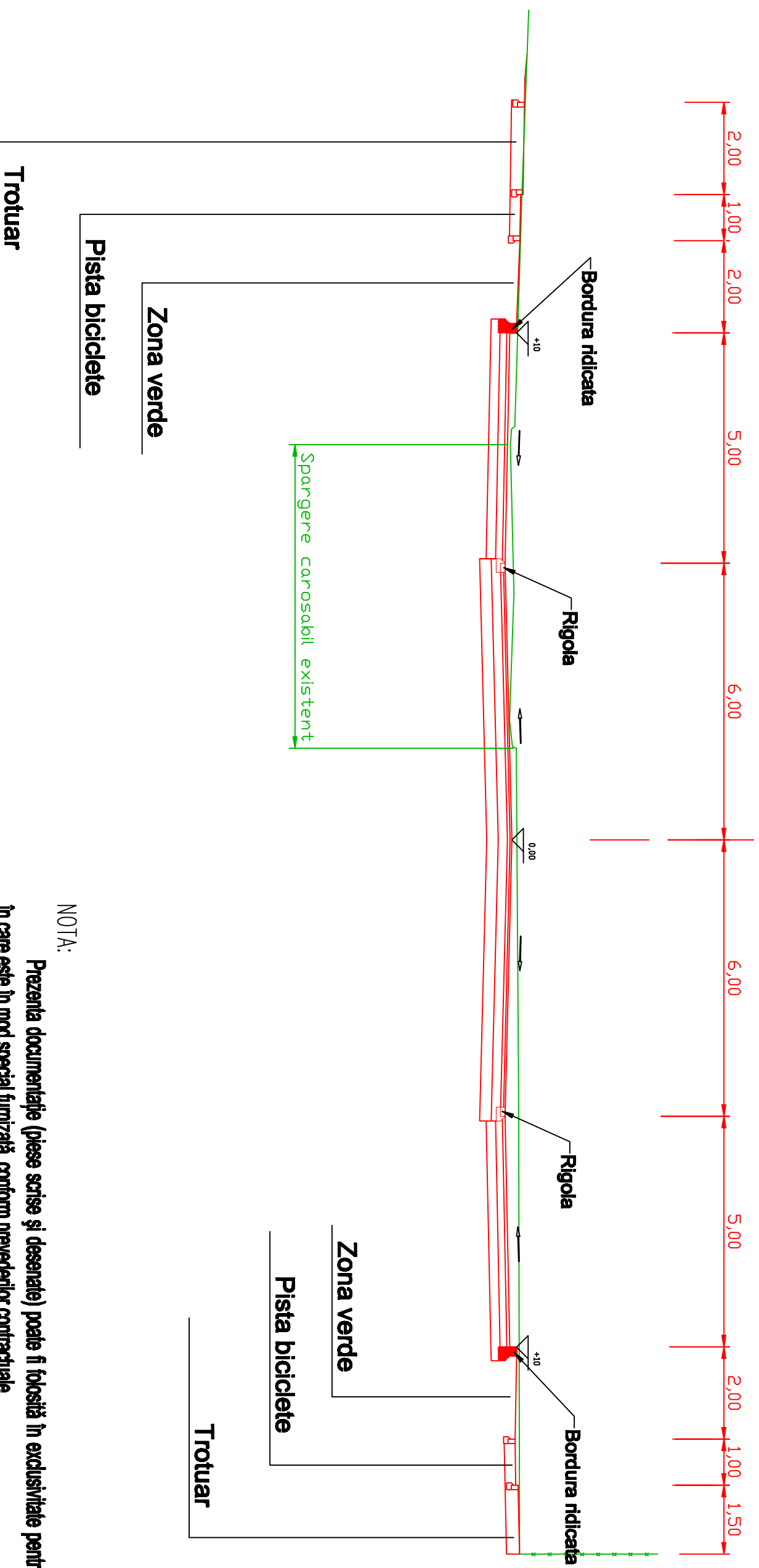

PARCARE



NOTA:

Prezenta documentatie (piese scrise si desenate) poate fi folosita în exclusivitate pentru scopul în care este în mod special furnizata, conform prevederilor contractuale.

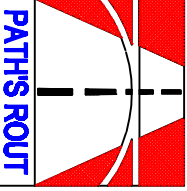
Detaliile de structurii rutiere si de încadrare a acestora sunt prezentate pe plansa nr. 14.014/1 - 04D

 sc PATHS ROUT SRL Tel/fax: 0256-216833, 291052 300430 TIMISOARA, Str. E.Zde 92 E-mail: secretaria@pathsroutr.ro ORC J 35723V/196, CUI: RO7267049 Capital social: 640.000 lei		 TUV AUSTRIA SINCE 1862		Proiect: EXTINDERE LA 4 BENZI STRADA PROF.DR. AUREL PAUNESCU-PODEANU Loc constr: STRADA AUREL PAUNESCU-PODEANU Beneficiar: MUNICIPIUL TIMISOARA		Nr.proiect: 14.014/1
DIRECTOR	Ing. PERCEC VASILE	SCARA	1:100	Obiect: EXTINDERE LA 4 BENZI STRADA PODEANU	Nr.plan	
SEF PROIECT	Ing. TOTI CAROL			Plansa: PROFIL TRANSVERSAL TIP NR. 2	03D/2	
PROIECTANT	Ing. TOTI CAROL	Data:	NOV.2014			

SE APLICA INTRE KM 0+445 SI KM 0+590

STATIONARE

STRADA PODEANU PARCARE

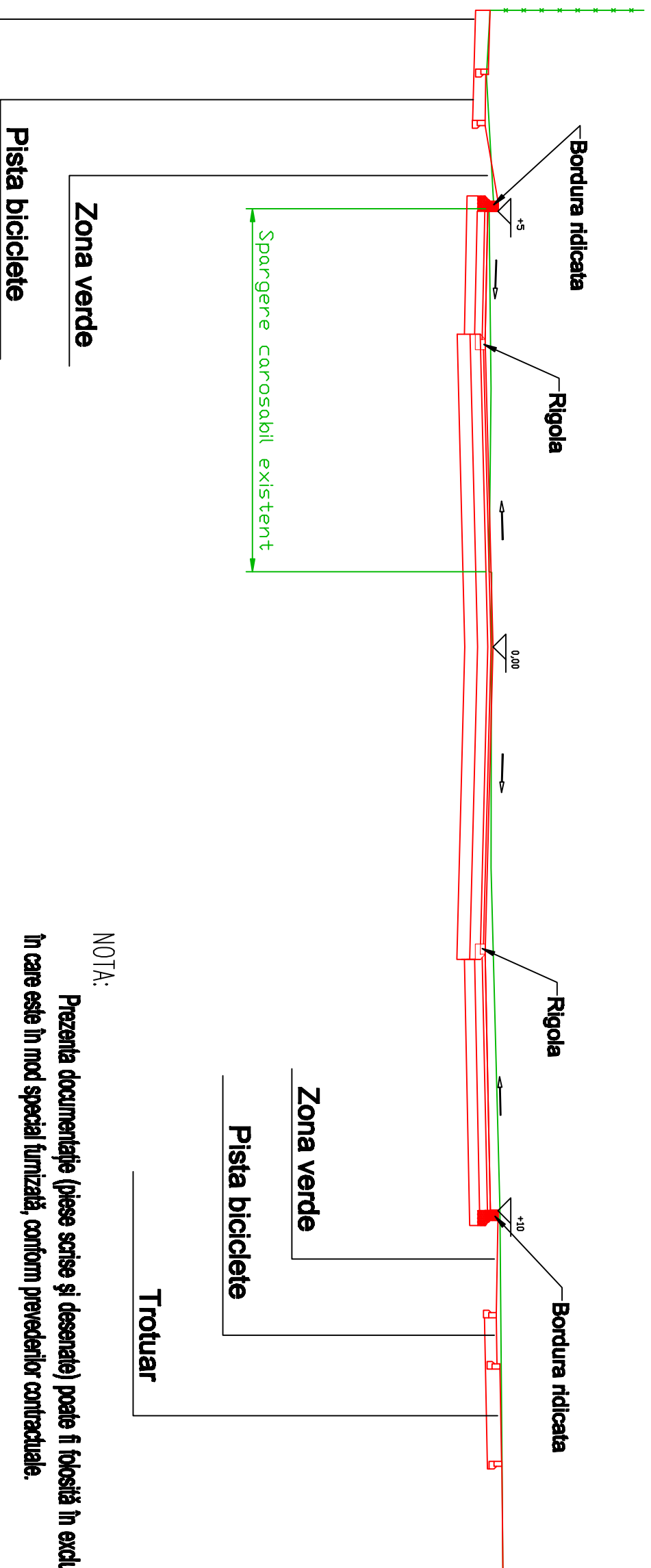
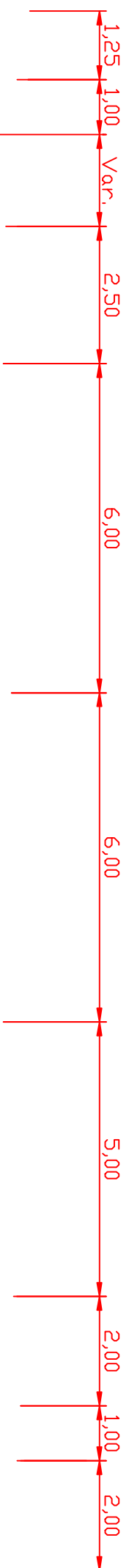

NOTA:
Prezenta documentatie (piese scrise si desenate) poate fi folosita în exclusivitate pentru scopul în care este în mod special furnizata, conform prevederilor contractuale.

Trotuar pe existent

Detaliile de structurii rutiere si de încadrare a acestora sunt prezentate pe planşa nr. 14.014/1 - 04D

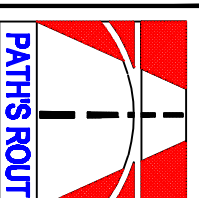

SC PATH'S ROUT SRL
Tel/fax: 0256-216833, 291052
300430 TIMISOARA, Str. E.Zola 92
E-mail: secretaria@pathroutr.ro
ORC J 35729/196, CUI: RO7267049
Capital social: 640.000 lei



Proiect:

EXTINDERE LA 4 BENZI STRADA PROF.DR. AUREL PAUNESCU-PODEANU

Nr.proiect:

14.014/1

Loc constr: STRADA AUREL PAUNESCU-PODEANU

Beneficiar: MUNICIPIUL TIMISOARA

Faza: P.I.01E

DIRECTOR

ing. PERCEC VASILE

SCARA

Obiect: EXTINDERE LA 4 BENZI STRADA PODEANU

Nr.plan

SEF PROIECT

ing. TOTH CAROL

1:100

Planşa: PROFIL TRANSVERSAL TIP NR. 3

03D/3

PROIECTANT

ing. TOTH CAROL

Data:

NOV/2014

SE APLICA INTRE KM 0+720 SI KM 0+868

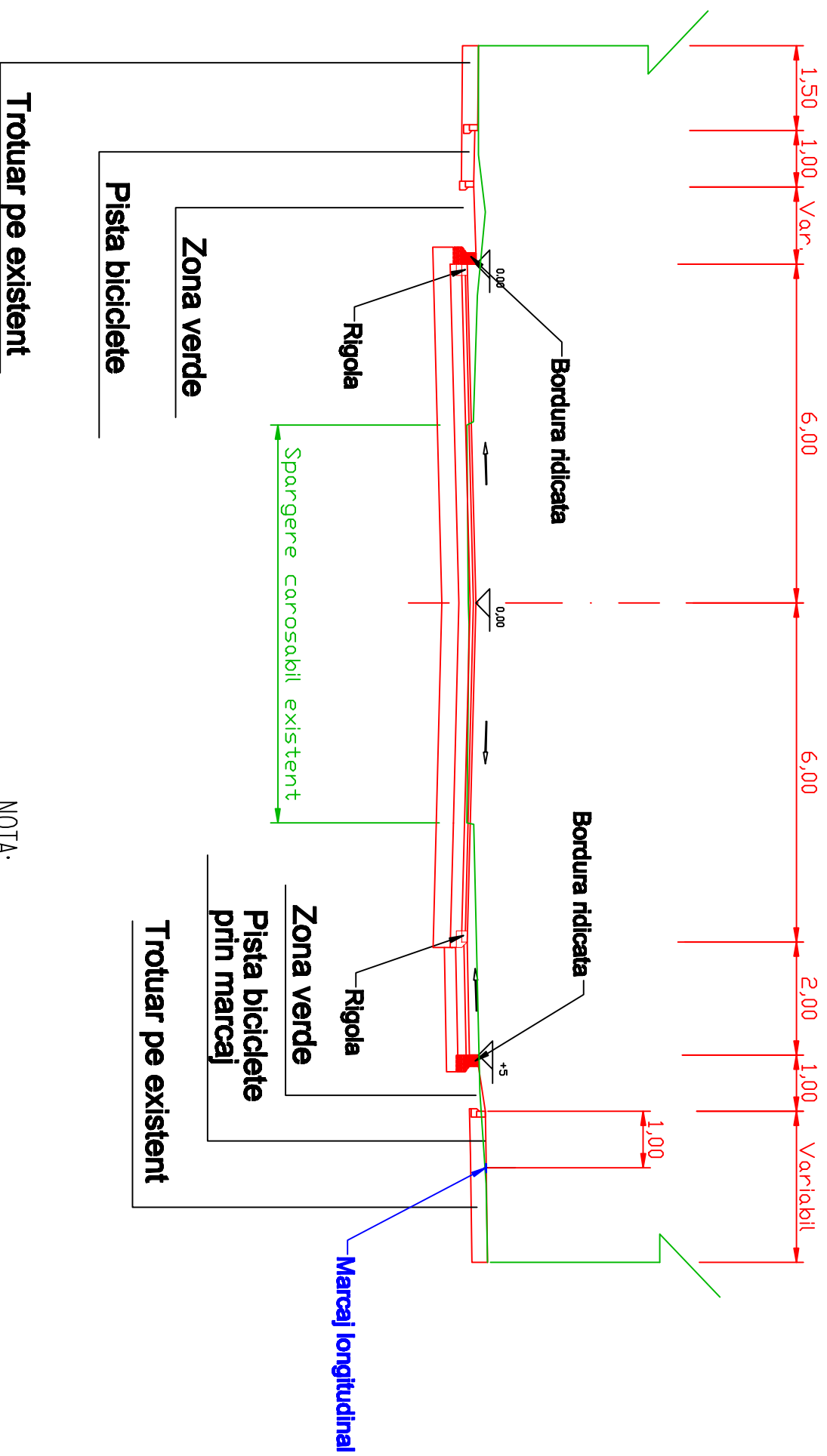

STRADA PODEANU STATIONARE



NOTA:

Prezenta documentație (piese scrise și desenate) poate fi folosită în exclusivitate pentru scopul în care este în mod special furnizată, conform prevederilor contractuale.

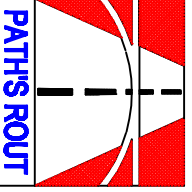
Detaliile de structurii rutiere și de încadrare a acestora sunt prezentate pe planșa nr. 14.014/1 - 04D

			
sc PATHS ROUT SRL Tel/fax: 0256-216833, 291052 300430 TIMISOARA, Str. E.Zola 92 E-mail: secretariat@pathsroutr.ro ORC J 35729/196, CUI: RO7267049 Capital social: 640.000 lei			
DIRECTOR	ing. PERCEC VASILE	SCARA	
SEF PROIECT	ing. TOTI CAROL	1:100	
PROIECTANT	ing. TOTI CAROL	Data:	NOV/2014
Proiect:	Nr. proiect:		
EXTINDERE LA 4 BENZI STRADA PROF. DR. AUREL PAUNESCU-PODEANU	14.014/1		
Loc constr:	STRADA AUREL PAUNESCU-PODEANU	Faza:	P.I./DE
Beneficiar:	MUNICIPIUL TIMISOARA		
Obiect:	EXTINDERE LA 4 BENZI STRADA PODEANU	Nr. plan	
Planșa:	PROFIL TRANSVERSAL TIP NR. 4	03D/4	