

Name: _____		Date: _____		Event: _____	
City: _____		State: _____		Track: _____	
Track	<input type="checkbox"/> Indoor	<input type="checkbox"/> Tight	<input type="checkbox"/> Smooth	<input type="checkbox"/> Hard Packed	<input type="checkbox"/> Blue Groove
Conditions	<input type="checkbox"/> Outdoor	<input type="checkbox"/> Open	<input type="checkbox"/> Rough	<input type="checkbox"/> Loose/Loamy	<input type="checkbox"/> Dry
	<input type="checkbox"/> Wet	<input type="checkbox"/> Low Bite	<input type="checkbox"/> High Bite	<input type="checkbox"/> Med Bite	<input type="checkbox"/> Other _____
	<input type="checkbox"/> Dusty				

Front Suspension

Toe: _____

Ride Height: _____

Camber: _____

Caster: _____

Wheel Hex: _____

Sway Bar: _____

Piston/Oil: _____

Spring: _____

Limiters/Droop: _____

Overall Shock Length: _____

Steering Ackerman: _____

Bump Steer: _____

Camber Link: _____

Shock Location: _____

Receiver Battery Type: _____

Differentials

Front: Standard Smart

Spring Wire Dia: _____

Qty of Springs: _____

Ramp Plate: _____

Grease: _____

Diff Fluid: _____

Center: Standard Smart

Spring Wire Dia: _____

Qty of Springs: _____

Ramp Plate: _____

Grease: _____

Diff Fluid: _____

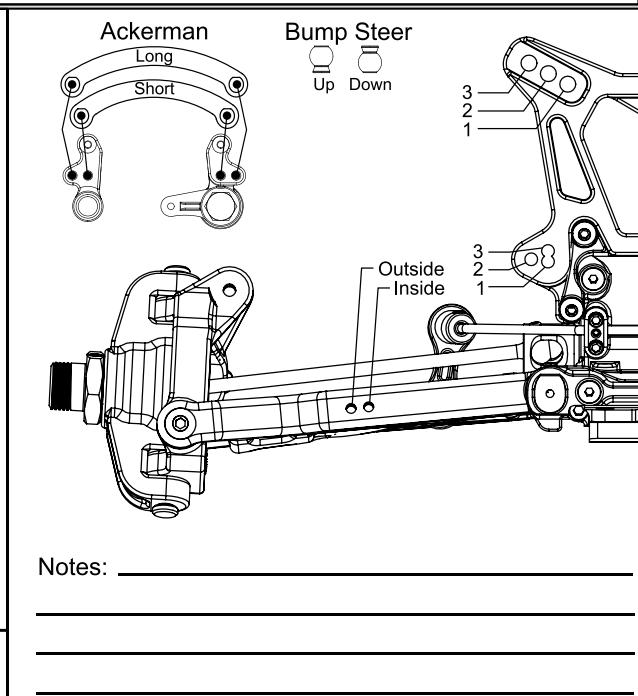

Rear Suspension

Roll Center: HRC LRC

Toe: _____

Anti-Squat: _____

Ride Height: _____

Camber: _____

Rear Hub Spacing: _____

Wheel Hex: _____

Sway Bar: _____

Piston/Oil: _____

Spring: _____

Limiters/Droop: _____

Overall Shock Length: _____

Camber Link: _____

Shock Location: _____

Rear Diff Fluid: _____

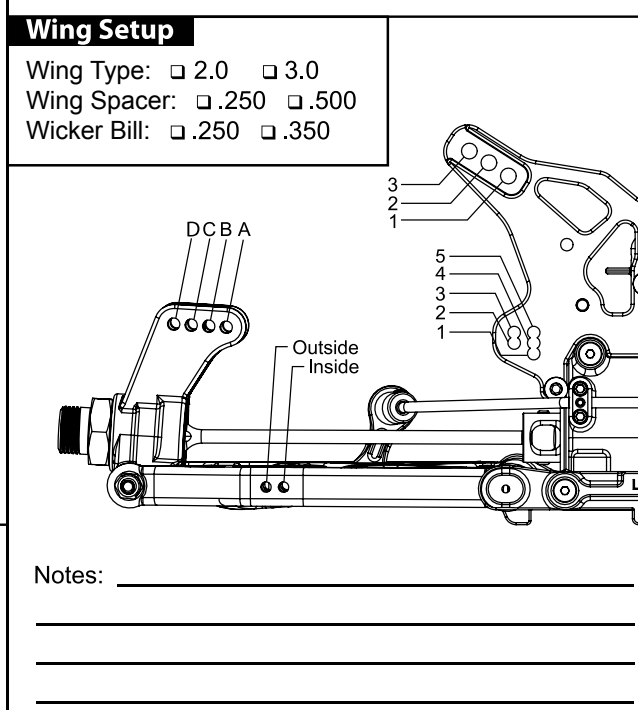

Electronics

Radio: _____ Servo Expo: _____

Servo: _____ Motor: _____

ESC: _____ Pinion: _____

Initial Brake: _____ Spur: _____

Drag Brake: _____ Battery: _____

Throttle Profile: _____

Timing Advance: _____

Throttle/Brake Expo: _____

Throttle/Brake EPA: _____

Tires

	Type	Compound	Insert
Front:	_____	_____	_____
Rear:	_____	_____	_____
Notes:	_____		