

ANNAPOLIS HOT MODEL # SCXADH

SPECIFICATIONS

The Express Annapolis Hot Euro Deli SCXADH Series is a hot display case ideal for prepared foods. Available with a choice of standard grade plastic laminate exterior ends and with lift-up curved front tempered glass for easy cleaning and stocking.



NOTE: EXCEEDS STANDARD 36" DOOR
OPENING FOR INSTALLATION ACCESS

Available lengths: 51 1/8" 63 1/8" 75 1/4" 99 1/4"

Available depths: 43 7/8"

Available heights: 52 1/4"



STANDARD FEATURES

- Lift-Up Curved Front Tempered Glass
- Heavy Gauge Steel Frame Base Construction
- Standard Grade Laminate Exterior
- Stainless Steel Back
- Black Base
- Rear Work Ledge with Zip Lite Cutting Board
- Brushed Aluminum Interior Ends
- Top Canopy Light
- Standard Pan Size Hot Well
4' - 3 Pans / 6' - 5 Pans / 8' - 6 Pans
with Common Drain Manifold
- Clear Plexi Rear Sliding Doors
- Stainless Steel Deck Pan
- Hardwire Direct
- ETL Listed in Accordance with UL 471
and NSF 4 Standards
- 1 Year Parts and Labor Warranty
- Floor Drain Required

OPTIONAL FEATURES

- Stainless Steel Exterior Finish
 #4 #6 #8
- Special Laminates
- Wood Veneers (Unfinished)
- Wood Veneers (Stained & Sealed)
- Miscellaneous Trim
- Brass Trim and Hardware
- Promolux Lighting (Low UV)
- Casters (Increases Height by 4")
- Adjustable Legs (Consult Factory for Sizes)
- Mirrored Polished Stainless Steel Interior Ends (#8 Finish)
- Mirrored Polished Stainless Steel Perforated Interior Back Panel (#8 Finish)
- Mirrored Plexi Rear Sliding Doors
- Corian® Rear Work Ledge
- Zodiac® Rear Work Ledge
- Tempered Glass Vision End Panels
 1/2 Glass End Panels
- Front Glass Locks
- Rear Door Locks
- Top Warming Unit
- Food Warmer

CALL TOLL FREE: 800-525-3692 (609-714-2330)

FAX: 609-714-2331 www.rpiindustries.com

220 ROUTE 70, MEDFORD, NJ 08055



INDUSTRIES, INC.

Warehouse Store Fixture Co.

v1.13

ANNAPOLIS HOT MODEL # SCXADH

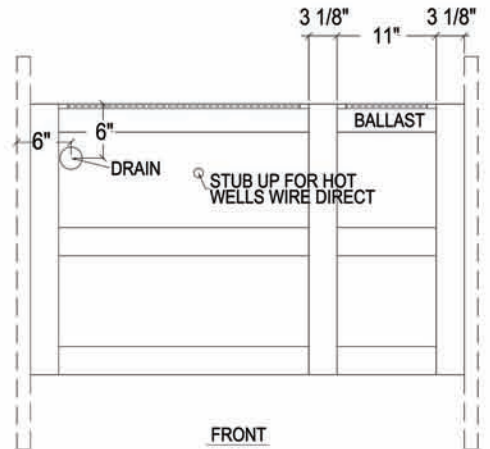
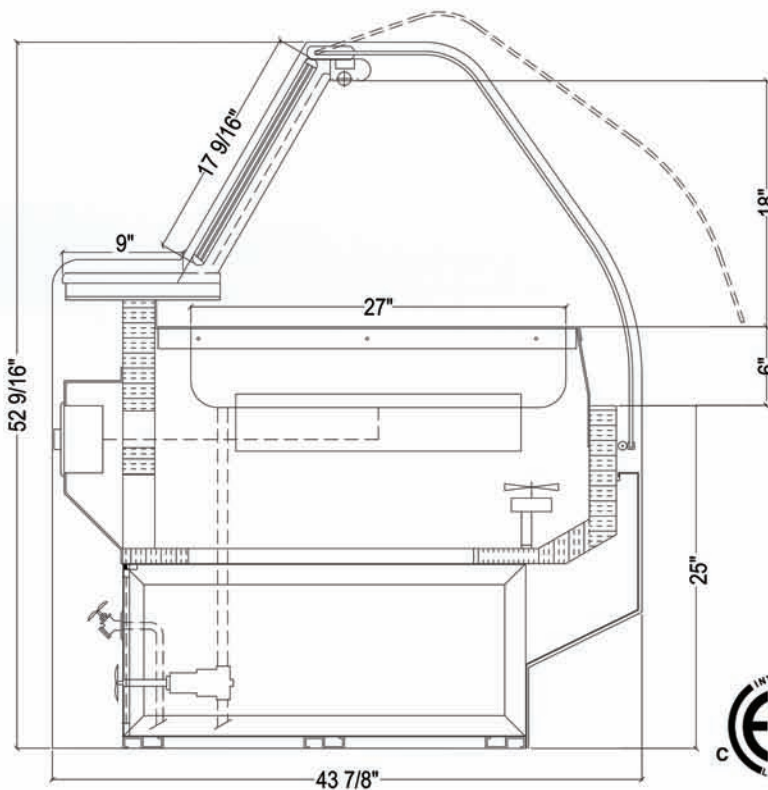

Electrical & Plumbing locations

UNIT SHOWN WITH STANDARD SOLID END PANELS



MODEL	L	D	H	VOLT	AMP	PLUG	WT	WELLS
SCXAD48H	51 1/8	43 7/8	52 1/4	115-208/230	15.5	Hardwire	700	3
SCXAD60H	63 1/8	43 7/8	52 1/4	115-208/230	17.4	Hardwire	780	4
SCXAD72H	75 1/4	43 7/8	52 1/4	115-208/230	22.4	Hardwire	850	5
SCXAD96H	99 1/4	43 7/8	52 1/4	115-208/230	25.5	Hardwire	1000	6

- Unit must be run to a floor drain at time of installation.
 - The SCXADH merchandiser is designed for use in stores where temperature and humidity do not exceed 75 degrees F and 55% R.H. Locate away from direct sunlight and extreme temperature changes. Exposure to air currents from ceiling fans, air conditioners may disrupt the performance of this case. Any adverse field conditions stated above will void warranty.
- RPI in line with it's current policy to continually improve it's product reserves the right to change materials and specifications without notice.

CALL TOLL FREE: 800-525-3692 (609-714-2330)
FAX: 609-714-2331 www.rpiindustries.com
220 ROUTE 70, MEDFORD, NJ 08055

