

Dystrybutor produktów z katalogu



**unihurt.pl**

narzędzia i oprzyrządowanie dla przemysłu

Sklep internetowy

[internarzedzia.pl](http://internarzedzia.pl)

Wyślij zapytanie

[info@unihurt.pl](mailto:info@unihurt.pl)

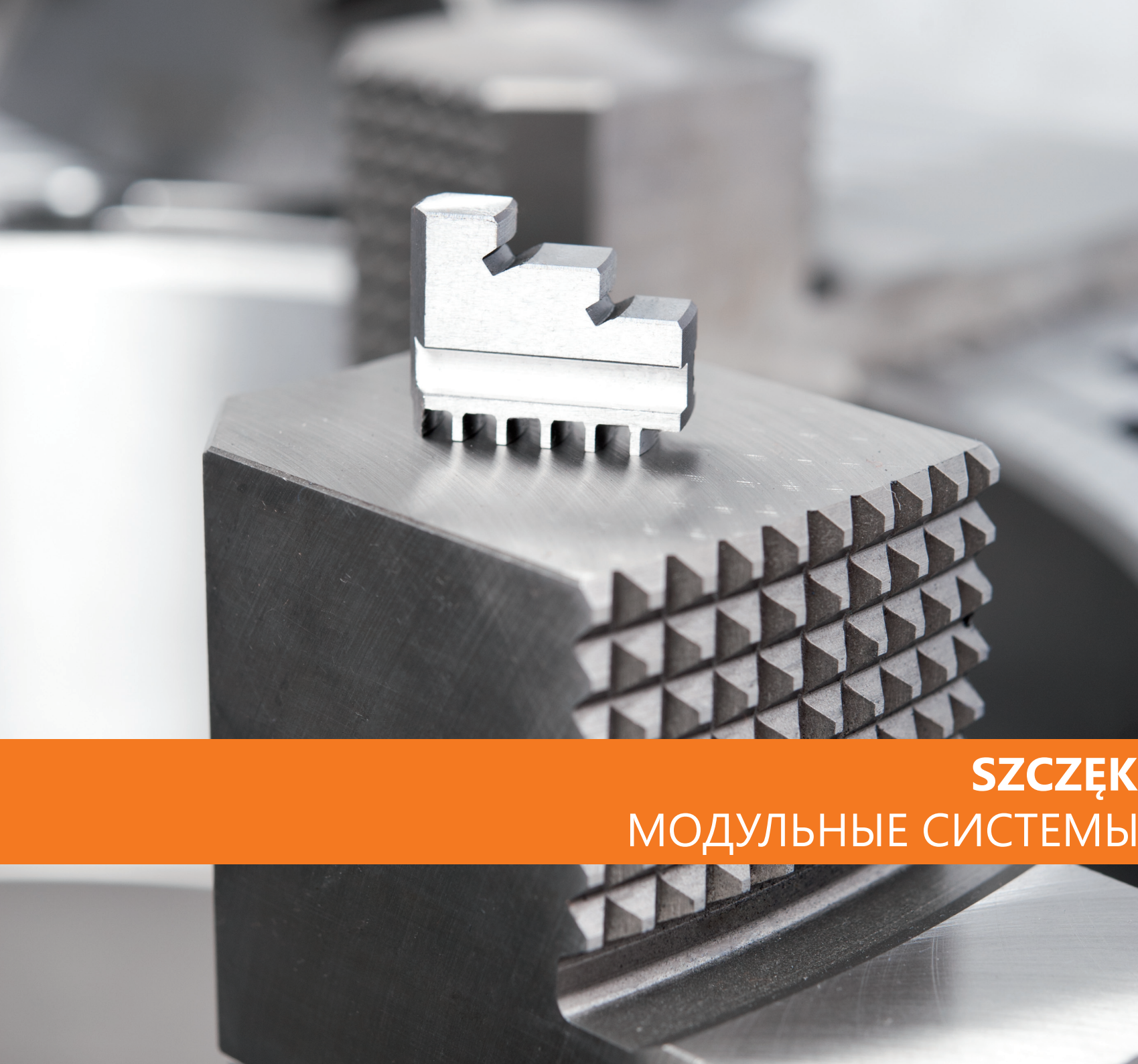

**SZCZĘKI MOCUJĄCE**  
**МОДУЛЬНЫЕ СИСТЕМЫ КРЕПЛЕНИЯ**

Dystrybucja: [unihurt.pl](mailto:unihurt.pl)



Zamówienia: [info@unihurt.pl](mailto:info@unihurt.pl)





**BISON NIEUSTANNIE PRODUKUJE WYSOKIEJ JAKOŚCI SZCZĘKI DO UCHWYTÓW TOKARSKICH - DOSKONALONYCH PRZEZ DZIESIĘCIOLECIA I CENIONYCH ZA ICH JAKOŚĆ.**

- Oferujemy szczęki mocujące do większości uchwytów tokarskich na całym świecie
- Szczęki produkowane przez BISON wykonane są z wysokiej jakości stali i aluminium
- Nasza oferta zawiera szczęki z wpustem i rowkiem oraz z metrycznym jak i z calowym zazębieniem szczęk
- Szlifowane ząbki w szczękach zapewniają dodatkową stabilność i dokładność mocowania obrabianego przedmiotu
- Oprócz standardowego programu szczęk, oferujemy naszym klientom kompleksowe rozwiązania dedykowane do konkretnych zastosowań

**NASZYM GŁÓWNYM CELEM JEST UTRZYMANIE POZYCJI ŚWIATOWEGO LIDERA W DOSTARCZANIU ROZWIĄZAŃ DO PRECYZYJNEJ OBRÓBKI Z NAJLEPSZYM WSPÓŁCZYNNIEM CENA/JAKOŚĆ !**

**NASZ DOTYCHCZASOWY PROGRAM ZOSTAŁ POSZERZONY O SZCZĘKI ZAPROJEKTOWANE DO PRACY Z UCHWYTAMI TAKICH PRODUCENTÓW JAK: SCHUNK, FORKARDT, KITAGAWA, MMK-MATSUMOTO, RÖHM, SMW-AUTOBLOK, BERG.**

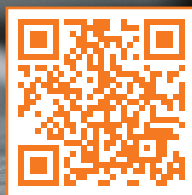

**NASZ NOWY PROGRAM SZCZĘK  
ZNAJDZIESZ NA STRONIE INTERNETOWEJ  
WWW.MYJAWFINDER.COM**

**НАША НОВАЯ ПРОГРАММА КУЛАЧКОВ  
НАХОДИТСЯ НА САЙТЕ  
WWW.MYJAWFINDER.COM**

**BISON ПОСТОЯННО ПРОИЗВОДИТ ВЫСОКОКАЧЕСТВЕННЫЕ КУЛАЧКИ ДЛЯ ТОКАРНЫХ ПАТРОНОВ УСОВЕРШЕНСТВОВАННЫХ В ТЕЧЕНИЕ ДЕСЯТИЛЕТИЙ И УВАЖАЕМЫХ ЗА ИХ КАЧЕСТВО.**

- Предлагаем кулачки для большинства токарных патронов по всему Миру
- Кулачки производимые BISON, изготовлены из высококачественной стали и алюминия
- Наше предложение включает в себя кулачки со шпоночным пазом а также метрической и дюймовой насечкой зуба
- Отшлифованные зубы, кулачков обеспечивают дополнительную стабильность и точность крепления обрабатываемой детали
- Помимо стандартной программы кулачков, предлагаем нашим клиентам комплексные решения, предназначенные для специфических применений.

**НАШЕЙ ГЛАВНОЙ ЦЕЛЬЮ ЯВЛЯЕТСЯ СОХРАНЕНИЕ ПОЗИЦИИ МИРОВОГО ЛИДЕРА В ОБЛАСТИ РЕШЕНИЙ ДЛЯ ТОЧНОЙ ОБРАБОТКИ С ЛУЧШИМ СООТНОШЕНИЕМ ЦЕНА/КАЧЕСТВО !**

**НАША СУЩЕСТВУЮЩАЯ ПРОГРАММА БЫЛА РАСШИРЕНА НА КУЛАЧКИ ПРЕДНАЗНАЧЕННЫЕ ДЛЯ РАБОТЫ С ПАТРОНАМИ ТАКИХ ПРОИЗВОДИТЕЛЕЙ, КАК: SCHUNK, FORKARDT, KITAGAWA, MMK-MATSUMOTO, RÖHM, SMW-AUTOBLOK, BERG.**

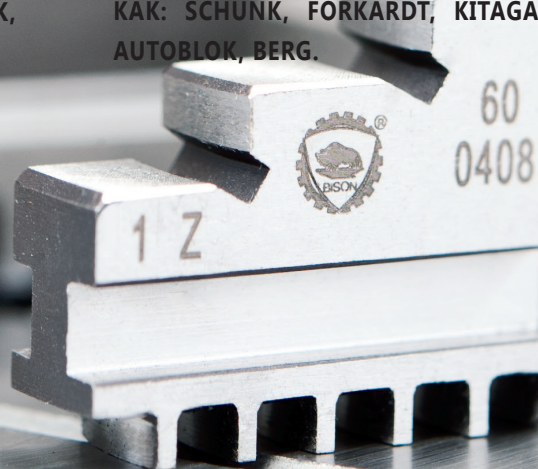



## I SZCZĘKI DO UCHWYTÓW SAMOCENTRUJĄCYCH SPIRALNYCH BISON 352-363 КУЛАЧКИ ДЛЯ ПАТРОНОВ САМОЦЕНТРИРУЮЩИХ СПИРАЛЬНЫХ BISON

TYP SZCZEK ТИП КУЛАЧКОВ	STRONA СТРАНИЦА
SZCZĘKI JEDNOLITE TWARDE КУЛАЧКИ ЦЕЛЬНЫЕ КАЛЕННЫЕ	352-354
SZCZĘKI JEDNOLITE MIEKKIE КУЛАЧКИ МЯГКИЕ ЦЕЛЬНЫЕ	355
SZCZĘKI GÓRNE TWARDE КУЛАЧКИ КАЛЕННЫЕ НАКЛАДНЫЕ	356-357
SZCZĘKI GÓRNE MIEKKIE КУЛАЧКИ МЯГКИЕ НАКЛАДНЫЕ (СЫРЫЕ)	358
SZCZĘKI PODSTAWOWE КУЛАЧКИ МАСТЕР (РЕЙКИ)	359-360
SZCZĘKI DZIELONE TWARDE КУЛАЧКИ СБОРНЫЕ КАЛЕННЫЕ	361-362
SZCZĘKI DZIELONE MIEKKIE КУЛАЧКИ СБОРНЫЕ МЯГКИЕ	363

## II SZCZĘKI DO UCHWYTÓW SAMOCENTRUJĄCYCH SPIRALNYCH CT BISON 364-365 КУЛАЧКИ ДЛЯ ПАТРОНОВ САМОЦЕНТРИРУЮЩИХ СПИРАЛЬНЫХ CT BISON

TYP SZCZEK ТИП КУЛАЧКОВ	STRONA СТРАНИЦА
SZCZĘKI JEDNOLITE TWARDE КУЛАЧКИ ЦЕЛЬНЫЕ КАЛЕННЫЕ	364
SZCZĘKI JEDNOLITE MIEKKIE КУЛАЧКИ МЯГКИЕ ЦЕЛЬНЫЕ	364
SZCZĘKI PODSTAWOWE КУЛАЧКИ МАСТЕР (РЕЙКИ)	365

## III SZCZĘKI DO UCHWYTÓW Z PODWÓJNYMI PROWADNICAMI BISON 366-368 КУЛАЧКИ ДЛЯ ПАТРОНОВ С ДВОЙНЫМИ НАПРАВЛЯЮЩИМИ BISON

TYP SZCZEK ТИП КУЛАЧКОВ	STRONA СТРАНИЦА
SZCZĘKI JEDNOLITE TWARDE КУЛАЧКИ ЦЕЛЬНЫЕ КАЛЕННЫЕ	366
SZCZĘKI JEDNOLITE MIEKKIE КУЛАЧКИ МЯГКИЕ ЦЕЛЬНЫЕ	367
SZCZĘKI PODSTAWOWE КУЛАЧКИ МАСТЕР (РЕЙКИ)	368

## IV SZCZĘKI DO UCHWYTÓW RÖHM ZG/ZGU-ZS/ZSU 369-372 КУЛАЧКИ ДЛЯ ПАТРОНОВ RÖHM ZG/ZGU-ZS/ZSU

TYP SZCZEK ТИП КУЛАЧКОВ	STRONA СТРАНИЦА
SZCZĘKI JEDNOLITE TWARDE КУЛАЧКИ ЦЕЛЬНЫЕ КАЛЕННЫЕ	369
SZCZĘKI JEDNOLITE MIEKKIE КУЛАЧКИ МЯГКИЕ ЦЕЛЬНЫЕ	370
SZCZĘKI GÓRNE TWARDE КУЛАЧКИ КАЛЕННЫЕ НАКЛАДНЫЕ	371
SZCZĘKI GÓRNE MIEKKIE КУЛАЧКИ МЯГКИЕ НАКЛАДНЫЕ (СЫРЫЕ)	371
SZCZĘKI PODSTAWOWE КУЛАЧКИ МАСТЕР (РЕЙКИ)	372

## V SZCZĘKI DO UCHWYTÓW SAMOCENTRUJĄCYCH ZĘBATKOWYCH BISON 373-376 КУЛАЧКИ ДЛЯ ПАТРОНОВ САМОЦЕНТРИРУЮЩИХ КЛИНОРЕЕЧНЫХ BISON

TYP SZCZEK ТИП КУЛАЧКОВ	STRONA СТРАНИЦА
SZCZĘKI JEDNOLITE TWARDE КУЛАЧКИ ЦЕЛЬНЫЕ КАЛЕННЫЕ	373
SZCZĘKI GÓRNE TWARDE КУЛАЧКИ КАЛЕННЫЕ НАКЛАДНЫЕ	373
SZCZĘKI GÓRNE MIEKKIE КУЛАЧКИ МЯГКИЕ НАКЛАДНЫЕ (СЫРЫЕ)	374
SZCZĘKI PODSTAWOWE КУЛАЧКИ МАСТЕР (РЕЙКИ)	375
SZCZĘKI DZIELONE TWARDE КУЛАЧКИ СБОРНЫЕ КАЛЕННЫЕ	376
SZCZĘKI DZIELONE MIEKKIE КУЛАЧКИ СБОРНЫЕ МЯГКИЕ	376

SZCZĘKI DO UCHWYTÓW SCHUNK, RÖHM, SMW-AUTOBLOK I FORKARDT DOSTĘPNE W ROZDZIALE C  
КУЛАЧКИ ДЛЯ ПАТРОНОВ SCHUNK, RÖHM, SMW-AUTOBLOK I FORKARDT ДОСТУПНЫЕ В РАЗДЕЛЕ C

## VI SZCZĘKI DO UCHWYTÓW KOMBINOWANYCH BISON 377-378 КУЛАЧКИ ДЛЯ ПАТРОНОВ КОМБИНИРОВАННЫХ BISON

TYP SZCZEK ТИП КУЛАЧКОВ	STRONA СТРАНИЦА
SZCZĘKI JEDNOLITE TWARDE КУЛАЧКИ ЦЕЛЬНЫЕ КАЛЕННЫЕ	377
SZCZĘKI JEDNOLITE MIEKKIE КУЛАЧКИ МЯГКИЕ ЦЕЛЬНЫЕ	378
SZCZĘKI PODSTAWOWE КУЛАЧКИ МАСТЕР (РЕЙКИ)	378

## VII SZCZĘKI DO UCHWYTÓW Z NIEZALEŻNYM NASTAWIENIEM SZCZEK BISON 379-387 КУЛАЧКИ ДЛЯ ПАТРОНОВ С НЕЗАВИСИМЫМ ПЕРЕМЕЩЕНИЕМ КУЛАЧКОВ BISON

TYP SZCZEK ТИП КУЛАЧКОВ	STRONA СТРАНИЦА
SZCZĘKI JEDNOLITE TWARDE КУЛАЧКИ ЦЕЛЬНЫЕ КАЛЕННЫЕ	379
SZCZĘKI JEDNOLITE MIEKKIE КУЛАЧКИ МЯГКИЕ ЦЕЛЬНЫЕ	380
SZCZĘKI GÓRNE TWARDE КУЛАЧКИ КАЛЕННЫЕ НАКЛАДНЫЕ	380-382
SZCZĘKI GÓRNE MIEKKIE КУЛАЧКИ МЯГКИЕ НАКЛАДНЫЕ (СЫРЫЕ)	383
SZCZĘKI PODSTAWOWE КУЛАЧКИ МАСТЕР (РЕЙКИ)	384-385
SZCZĘKI DZIELONE MIEKKIE КУЛАЧКИ СБОРНЫЕ МЯГКИЕ	386
SZCZĘKI DZIELONE TWARDE КУЛАЧКИ СБОРНЫЕ КАЛЕННЫЕ	386-387

A

Dystrybucja: unihurt.pl  
Zamówienia: info@unihurt.pl  
SZCZĘKI DO UCHWYTÓW TOKARSKICH Z MOCOWANIEM REŚNYM  
MÓWNIENIEM ODMIENNYM



## VII SZCZĘKI DO UCHWYTÓW Z MOCOWANIEM MECHANICZNYM BISON КУЛАЧКИ ДЛЯ ТОКАРНЫХ ПАТРОНОВ С МЕХАНИЧЕСКИМ ЗАЖИМОМ BISON 388-401

### SZCZĘKI GÓRNE TWARDE • КУЛАЧКИ КАЛЕННЫЕ НАКЛАДНЫЕ 388-391

	OPIS ОПИСАНИЕ	WIELKOŚĆ KĄTA ZĄBKÓW ЗУБЧАТОЕ СОЕДИНЕНИЕ	MATERIAŁ МАТЕРИАЛ	STRONA СТРАНИЦА
S	DO 2405-K для типа 2405-K	METRYCZNA • 60° МЕТРИЧЕСКОЕ • 60°	STAL СТАЛЬ	388
S	DO 2405 для типа 2405	CAŁOWA • 90° ДЮЙМОВОЕ • 90°	STAL СТАЛЬ	388
S	DO 2605-K для типа 2605-K	METRYCZNA • 60° МЕТРИЧЕСКОЕ • 60°	STAL СТАЛЬ	389
S	DO 2605 для типа 2605	CAŁOWA • 90° ДЮЙМОВОЕ • 90°	STAL СТАЛЬ	389
S	DO 2409 для типа 2409	CAŁOWA • 90° ДЮЙМОВОЕ • 90°	STAL СТАЛЬ	390
S	DO 2488 для типа 2488	CAŁOWA • 90° ДЮЙМОВОЕ • 90°	STAL СТАЛЬ	391

### SZCZĘKI GÓRNE MIĘKKIE • КУЛАЧКИ МЯГКИЕ НАКЛАДНЫЕ (СЫРЫЕ) 392-397

	OPIS ОПИСАНИЕ	WIELKOŚĆ KĄTA ZĄBKÓW ЗУБЧАТОЕ СОЕДИНЕНИЕ	MATERIAŁ МАТЕРИАЛ	STRONA СТРАНИЦА
S	DO 2105-K для типа 2105-K	METRYCZNA • 60° МЕТРИЧЕСКОЕ • 60°	STAL СТАЛЬ	392
S	DO 2105 для типа 2105	CAŁOWA • 90° ДЮЙМОВОЕ • 90°	STAL СТАЛЬ	392
S	DO 2405-K для типа 2405-K	METRYCZNA • 60° МЕТРИЧЕСКОЕ • 60°	STAL СТАЛЬ	393
S	DO 2405 для типа 2405	CAŁOWA • 90° ДЮЙМОВОЕ • 90°	STAL СТАЛЬ	394
S	DO 2605-K для типа 2605-K	METRYCZNA • 60° МЕТРИЧЕСКОЕ • 60°	STAL СТАЛЬ	395
S	DO 2605 для типа 2605	CAŁOWA • 90° ДЮЙМОВОЕ • 90°	STAL СТАЛЬ	396
S	DO 2409 для типа 2409	CAŁOWA • 90° ДЮЙМОВОЕ • 90°	STAL СТАЛЬ	397
S	DO 2488 для типа 2488	CAŁOWA • 90° ДЮЙМОВОЕ • 90°	STAL СТАЛЬ	397

### SZCZĘKI CHWYТАКOWE • КУЛАЧКИ ЗУБЧАТЫЕ 398-401

	OPIS ОПИСАНИЕ	WIELKOŚĆ KĄTA ZĄBKÓW ЗУБЧАТОЕ СОЕДИНЕНИЕ	MATERIAŁ МАТЕРИАЛ	STRONA СТРАНИЦА
S	DO 2105-K для типа 2105-K	METRYCZNA • 60° МЕТРИЧЕСКОЕ • 60°	STAL СТАЛЬ	398-399
S	DO 2105 для типа 2105	CAŁOWA • 90° ДЮЙМОВОЕ • 90°	STAL СТАЛЬ	400-401





## VIII SZCZĘKI GÓRNE MIĘKIE КУЛАЧКИ МЯГКИЕ НАКЛАДНЫЕ (СЫРЫЕ) 402-431

### SZCZĘKI GÓRNE MIĘKIE • КУЛАЧКИ МЯГКИЕ НАКЛАДНЫЕ (СЫРЫЕ) 402-421

	WIELKOŚĆ KĄTA ZĄBKÓW ЗУБЧАТОЕ СОЕДИНЕНИЕ	MATERIAŁ МАТЕРИАЛ	STRONA СТРАНИЦА
S	METRYCZNA • 60° МЕТРИЧЕСКОЕ • 60°	STAL СТАЛЬ	402-405
A		ALUMINIUM АЛЮМИНИЙ	406-407
S	CALOWA • 90° ДЮЙМОВОЕ • 90°	STAL СТАЛЬ	408-411
A		ALUMINIUM АЛЮМИНИЙ	412-413
S	Z WPUSTEM I ROWKIEM С СИСТЕМОЙ ПАЗ-ШПОНКА	STAL СТАЛЬ	414-419
A		ALUMINIUM АЛЮМИНИЙ	420-421

### SZCZĘKI GÓRNE MIĘKIE BEZ OTWORÓW • КУЛАЧКИ МЯГКИЕ НЕОБРАБОТАННЫЕ НАКЛАДНЫЕ 422-425

	WIELKOŚĆ KĄTA ZĄBKÓW ЗУБЧАТОЕ СОЕДИНЕНИЕ	MATERIAŁ МАТЕРИАЛ	STRONA СТРАНИЦА
S	METRYCZNA • 60° МЕТРИЧЕСКОЕ • 60°	STAL СТАЛЬ	422-423
S	CALOWA • 90° ДЮЙМОВОЕ • 90°	STAL СТАЛЬ	424-425

### SZCZĘKI MIĘKIE Z PEŁNYM CHWYTEM • КУЛАЧКИ МЯГКИЕ СЕГМЕНТНЫЕ НАКЛАДНЫЕ 426-431

	WIELKOŚĆ KĄTA ZĄBKÓW ЗУБЧАТОЕ СОЕДИНЕНИЕ	MATERIAŁ МАТЕРИАЛ	STRONA СТРАНИЦА
S	METRYCZNA • 60° МЕТРИЧЕСКОЕ • 60°	STAL СТАЛЬ	426-427
A		ALUMINIUM АЛЮМИНИЙ	426-427
S	CALOWA • 90° ДЮЙМОВОЕ • 90°	STAL СТАЛЬ	428-429
A		ALUMINIUM АЛЮМИНИЙ	428-429
S	Z WPUSTEM I ROWKIEM С СИСТЕМОЙ ПАЗ-ШПОНКА	STAL СТАЛЬ	430-431
A		ALUMINIUM АЛЮМИНИЙ	430-431

## IX SZCZĘKI GÓRNE TWARDE КУЛАЧКИ КАЛЕННЫЕ НАКЛАДНЫЕ 432-485

### SZCZĘKI GÓRNE TWARDE • КУЛАЧКИ КАЛЕННЫЕ НАКЛАДНЫЕ 432-437

	WIELKOŚĆ KĄTA ZĄBKÓW ЗУБЧАТОЕ СОЕДИНЕНИЕ	MATERIAŁ МАТЕРИАЛ	STRONA СТРАНИЦА
S	METRYCZNA • 60° МЕТРИЧЕСКОЕ • 60°	STAL СТАЛЬ	432-433
S	CALOWA • 90° ДЮЙМОВОЕ • 90°	STAL СТАЛЬ	434-435
S	Z WPUSTEM I ROWKIEM С СИСТЕМОЙ ПАЗ-ШПОНКА	STAL СТАЛЬ	436-437

### SZCZĘKI CHWYTAKOWE • КУЛАЧКИ ЗУБЧАТЫЕ 438-479

	WIELKOŚĆ KĄTA ZĄBKÓW ЗУБЧАТОЕ СОЕДИНЕНИЕ	MATERIAŁ МАТЕРИАЛ	STRONA СТРАНИЦА
S	METRYCZNA • 60° МЕТРИЧЕСКОЕ • 60°	STAL СТАЛЬ	438-447
S	CALOWA • 90° ДЮЙМОВОЕ • 90°	STAL СТАЛЬ	448-465
S	Z WPUSTEM I ROWKIEM С СИСТЕМОЙ ПАЗ-ШПОНКА	STAL СТАЛЬ	466-479

### SZCZĘKI CHWYTAKOWE DO MOCOWANIA WAŁKÓW • КУЛАЧКИ ЗУБЧАТЫЕ ДЛЯ ЗАЖИМА ВАЛОВ 480-485

	WIELKOŚĆ KĄTA ZĄBKÓW ЗУБЧАТОЕ СОЕДИНЕНИЕ	MATERIAŁ МАТЕРИАЛ	STRONA СТРАНИЦА
S	METRYCZNA • 60° МЕТРИЧЕСКОЕ • 60°	STAL СТАЛЬ	480-481
S	CALOWA • 90° ДЮЙМОВОЕ • 90°	STAL СТАЛЬ	482-483
S	Z WPUSTEM I ROWKIEM С СИСТЕМОЙ ПАЗ-ШПОНКА	STAL СТАЛЬ	484-485

## X SZCZĘKI DO UCHWYTÓW Z MOCOWANIEM MECHANICZNYM ZE ZINTEGROWANYM SYSTEMEM SZYBKIEJ WYMIANY SZCZĘK I UCHWYTÓW ZĘBĄTKOWYCH КУЛАЧКИ ДЛЯ ПАТРОНОВ С МЕХАНИЧЕСКИМ ЗАЖИМОМ С ИНТЕГРИРОВАННОЙ СИСТЕМОЙ БЫСТРОЙ СМЕНЫ КУЛАЧКОВ И ДЛЯ ПАТРОНОВ КЛИНОРЕЕЧНЫХ 486-491

### SZCZĘKI JEDNOLITE MIĘKIE • КУЛАЧКИ МЯГКИЕ ЦЕЛЬНЫЕ 486-487

### SZCZĘKI JEDNOLITE TWARDE • КУЛАЧКИ ЦЕЛЬНЫЕ КАЛЕННЫЕ 488-489

### SZCZĘKI PODSTAWOWE • КУЛАЧКИ МАСТЕР (РЕЙКИ) 490-491

## XI WKŁADKI TEOWE I AKCESORIA Т-ОБРАЗНЫЕ ВКЛАДКИ И АКССЕСУАРЫ 492-504

C

Dział Produkcji: unihurt.pl  
 Dystrybucja: unihurt.pl  
 Zamówienia: info@unihurt.pl  
 SZCZĘKI DO UCHWYTÓW Z MOCOWANIEM MECHANICZNYM I INNYCH PRODUKTÓW





SZCZĘKI JEDNOLITE TWARDE ZEWNĘTRZNE  
 КУЛАЧКИ ПРЯМЫЕ ЦЕЛЬНЫЕ КАЛЕННЫЕ

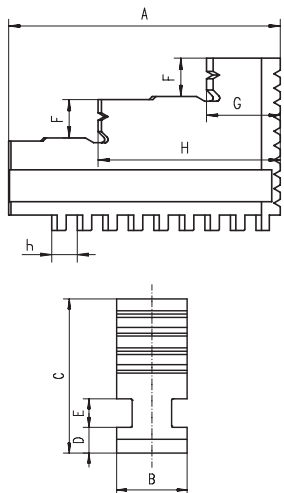
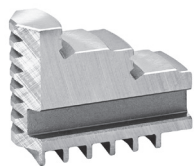

Uchwyt BISON	Wielkość uchwytu	Nr produktu	A	B	C	D	E	F	G	H	h	kg / szt.
Патрон BISON	Размер патрона	Код продукта										кг / шт.
32**, 35**	80	398535000900	32	11	28	6,0	6	6	9,5	21,0	4,0	0,03
3266	80	398535002400										
32**, 35**	100	398535010000	42	15	31	6,0	6	7	11,0	27,0	6,0	0,1
36**, 37**	100	398538197000										
3266	100	398535012600										
32**, 35**	125	398535020200	51	15	40	6,0	6	8	13,0	33,5	7,0	0,2
36**, 37**	125	398539020500										
38**	125	398540020900										
3266	125	398535022800										
32**, 35**	160	398535030400	70	20	53	8,0	8	10	19,0	45,0	8,0	0,4
36**, 37**	160	398539030700										
38**	160	398540030000										
3266	160	398535030400										
32**, 35**	200	398535040600	85	25	54	9,0	10	12	23,0	57,0	8,0	0,5
36**, 37**	200	398539040900										
38**	200	398540040200										
3266	200	398535040600										
32**, 35**	250	398535050800	105	28	63	11,0	12	14	28,0	69,5	9,0	0,8
36**, 37**	250	398539050000										
38**	250	398540050400										
32**, 35**	315	398535060000	125	32	73	12,7	12	18	34,5	83,0	10,0	1,3
36**, 37**	315	398539060200										
38**	315	398540060600										
32**, 35**	400	398535070100	145	36	92	15,0	14	22	36,0	99,0	12,0	2,4
36**, 37**	400	398539070400										
38**	400	398540070800										
32**, 35**	500	398535080300	180	40	100	16,0	14	26	50,0	119,5	14,2	3,4
36**, 37**	500	398539080600										
38**	500	398540080000										
32**, 35**	630	398535090500	225	50	110	16,0	14	28	66,0	149,0	14,2	5,8
36**, 37**	630	398539081900										
38**	630	398534900900										
32**, 35**	800	398535090500	225	50	110	16,0	14	28	66,0	149,0	14,2	5,8
36**, 37**	800	398539081900										
38**	800	398534901100										
32**, 35**	1000	398535201300	291	70	140	22,0	20	34	85,0	190,0	18,0	14,3
36**, 37**	1000	398539082100										
38**	1000	398534902400										

Ø 80 - 1000 mm

Dystrybucja: unihurt.pl



Zamówienia: info@unihurt.pl

1

2

3

4

5

6

7

A

SJZ



SZCZĘKI JEDNOLITE TWARDE WEWNTRZNE  
 КУЛАЧКИ ОБРАТНЫЕ ЦЕЛЬНЫЕ КАЛЕННЫЕ

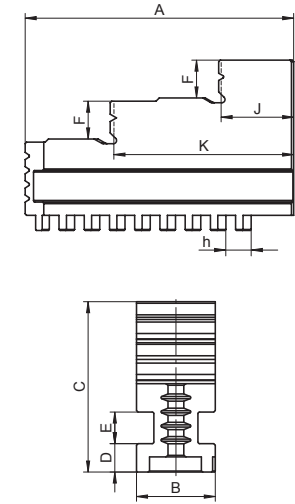
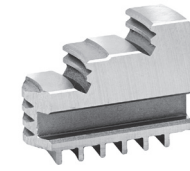

Uchwyt BISON	Wielkość uchwytu	Nr produktu	A	B	C	D	E	F	J	K	h	kg / szt.
												kg / szt.
Патрон BISON	Размер патрона	Код продукта										кг / шт.
32**, 35**	80	398535100000	32	11	28	6,0	6	6	9,5	21,0	4,0	0,03
3266	80	398535102500										0,03
32**, 35**	100	398535110100	42	15	31	6,0	6	7	11,0	27,0	6,0	0,1
37**	100	398538198200										0,1
3266	100	398535112700										0,1
32**, 35**	125	398535120300	51	15	40	6,0	6	8	13,0	33,5	7,0	0,2
36**, 37**	125	398539120600										0,2
38**	125	398540120000										0,2
3266	125	398535122900										0,2
32**, 35**	160	398535130500	70	20	53	8,0	8	10	19,0	45,0	8,0	0,4
36**, 37**	160	398539130800										0,4
38**	160	398540130100										0,4
3266	160	398535130500										0,4
32**, 35**	200	398535140700	85	25	54	9,0	10	12	23,0	57,0	8,0	0,5
36**, 37**	200	398539140000										0,5
38**	200	398540140300										0,5
3266	200	398535140700										0,5
32**, 35**	250	398535150900	105	28	63	11,0	12	14	28,0	69,5	9,0	0,8
36**, 37**	250	398539150100										0,8
38**	250	398540150500										0,8
32**, 35**	315	398535160000	125	32	73	12,7	12	18	34,5	83,0	10,0	1,3
36**, 37**	315	398539160300										1,3
38**	315	398540160700										1,3
32**, 35**	400	398535170200	145	36	92	15,0	14	22	36,0	99,0	12,0	2,4
36**, 37**	400	398539170500										2,4
38**	400	398540170900										2,4
32**, 35**	500	398535180400	180	40	100	16,0	14	26	50,0	119,5	14,2	3,4
36**, 37**	500	398539180700										3,4
38**	500	398540180000										3,4
32**, 35**	630	398535190600	225	50	110	16,0	14	28	66,0	149,0	14,2	5,8
36**, 37**	630	398539181000										5,8
38**	630	398535197500										5,8
32**, 35**	800	398535190600	225	50	110	16,0	14	28	66,0	149,0	14,2	5,8
36**, 37**	800	398539181000										5,8
38**	800	398535198800										5,8
32**, 35**	1000	398535211500	291	70	140	22,0	20	34	85,0	190,0	18,0	14,3
36**, 37**	1000	398539182200										14,3
38**	1000	398535199000										14,3

Ø 80 - 1000 mm

- 1
- 2
- 3
- 4
- 5
- 6

7

Dystrybucja: unihurt.pl



Zamówienia: info@unihurt.pl

MRS



- 1
- 2
- 3
- 4
- 5
- 6
- 7
- A



**SZCZĘKI JEDNOLITE TWARDE ODWRACALNE**  
 КУЛАЧКИ ЦЕЛЬНЫЕ КАЛЕННЫЕ ПЕРЕВОРАЧИВАЮЩИЕСЯ



	Uchwyt BISON	Wielkość uchwytu	Nr produktu
	Патрон BISON	Размер патрона	Код продукта
Ø 49 - 160 mm	3286	49	398539914200
	3286	60	398539915500
	3866	80	398541110600
	3867	85	398541160500
	3868	85	398541210700
	3866	100	398541120800
	3867	110	398541170700
	3866	125	398541130000
	3866	160	398541140100
	3867	160	398541180900

Dystrybucja: [unihurt.pl](http://unihurt.pl)  
 Zamówienia: [info@unihurt.pl](mailto:info@unihurt.pl)



SZCZĘKI JEDNOLITE MIĘKKIE  
 КУЛАЧКИ МЯГКИЕ ЦЕЛЬНЫЕ

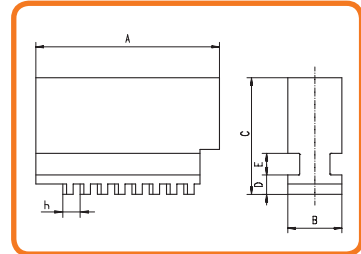
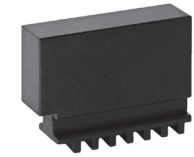

Uchwyt BISON	Wielkość uchwytu	Nr produktu	A	B	C	D	E	h	kg / szt.
									kg / szt.
Патрон BISON	Размер патрона	Код продукта							кг / шт.
32**; 35**	80	398536000700	32	11	28	6,0	6	4,0	0,1
32**; 35**	100	398536010900	42	15	31	6,0	6	6,0	0,1
37**	100	398539810000							
32**; 35**	125	398536020000	51	15	40	6,0	6	7,0	0,3
36**; 37**	125	398539820200							
38**	125	398540220000							
32**; 35**	160	398536030200	70	20	53	8,0	8	8,0	0,5
36**; 37**	160	398539830400							
38**	160	398540230200							
32**; 35**	200	398536040400	85	25	54	9,0	10	8,0	0,8
36**; 37**	200	398539840600							
38**	200	398540240400							
32**; 35**	250	398536050600	105	28	63	11,0	12	9,0	1,4
36**; 37**	250	398539850800							
38**	250	398540250600							
32**; 35**	315	398536060800	125	32	73	12,7	12	10,0	1,9
36**; 37**	315	398539860000							
38**	315	398540260800							
32**; 35**	400	398536070000	145	36	92	15,0	14	12,0	2,5
36**; 37**	400	398539870100							
38**	400	398540270000							
32**; 35**	500	398536080100	180	40	100	16,0	14	14,2	5,00
36**; 37**	500	398539880300							
38**	500	398540280100							
32**; 35**	630	398536090300	225	50	110	16,0	14	14,2	8,4
36**; 37**	630	398539890500							
38**	630	398540290300							
32**; 35**	800	398536092900	225	50	110	16,0	14	14,2	8,4
36**; 37**	800	398539891800							
38**-800	800	398540291600							
32**; 35**	1000	398536094400	290	70	140	22,0	20	18,0	20,3
36**; 37**	1000	398539892000							
38**	1000	398540292900							

Ø 80 - 1000 mm

- 1
- 2
- 3
- 4
- 5
- 6
- 7

Dystrybucja: unihurt.pl  
 Zamówienia: info@unihurt.pl  
 WRS



- 1
- 2
- 3
- 4
- 5
- 6
- 7
- A



**SZCZĘKI GÓRNE TWARDE**  
 КУЛАЧКИ КАЛЕННЫЕ НАКЛАДНЫЕ

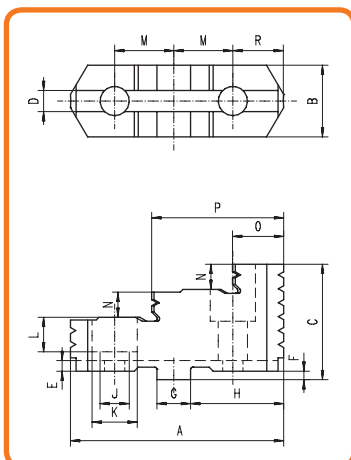

Uchwyt BISON	Wielkość uchwytu	Nr produktu	A	B	C	D	E	F	G	H	J	K	L	M	N	O	P	R	kg / szt.
			Патрон BISON	Размер патрона	Код продукта														
32**; 35**	125	398532820500	56	22,0	38,5	7,95	4,0	3,2	12,69	22,6	9	15	10,0	16,00	8,0	14,5	35,0	13,0	0,2
36**; 37**	125	398537820600																	
38**	125	398540820600	56	22,0	38,5	7,95	4,0	3,2	12,69	22,6	6,6	11	10,0	16,00	8,0	14,5	35,0	13,0	0,2
32**; 35**	160	398532830700	67	25,0	41,5	7,95	4,0	3,2	12,69	28,6	11	18	12,0	19,05	8,5	18,0	41,5	16,0	0,3
36**; 37**	160	398537830800																	
38**	160	398540830800																	
32**; 35**	200	398532840900	80	27,0	43,5	7,95	4,0	3,2	12,69	34,9	11	18	12,0	22,25	9,5	21,5	51,0	19,0	0,4
36**; 37**	200	398537840000																	
38**	200	398540840000																	
32**; 35**	250	398532850000	95	32,5	51,5	12,71	4,0	3,2	19,04	39,7	14	20	14,5	27,00	12,0	24,5	59,0	22,0	0,6
36**; 37**	250	398537850100																	
38**	250	398540850100																	
32**; 35**	315	398532860200	110	37,0	55,0	12,71	4,0	3,2	19,04	47,6	14	20	14,5	31,75	13,0	26,5	68,0	35,4	0,9
36**; 37**	315	398537860300																	
38**	315	398540860300																	
32**; 35**	400	398532870400	127	42,0	64,5	12,71	4,0	6,3	19,04	57,1	18	26	18,5	38,10	13,5	27,0	76,5	28,5	1,4
36**; 37**	400	398537870500																	
38**	400	398540870500																	
32**; 35**	500	398532880600	127	42,0	74,5	12,71	4,0	6,3	19,04	57,1	22	33	21,0	38,10	17,0	50,0	88,0	28,5	1,6
36**; 37**	500	398537880700																	
38**	500	398540880700																	
32**; 35**	630	398532890800	127	52,0	82,0	12,71	4,0	6,3	19,04	57,1	22	33	21,0	38,10	21,0	51,0	89,0	28,5	2,4
36**; 37**	630	398537890900																	
38**	630	398540890900																	
32**; 35**	800	398532890800	127	52,0	82,0	12,71	4,0	6,3	19,04	57,1	22	33	21,0	38,10	21,0	51,0	89,0	28,5	2,4
36**; 37**	800	398537900300																	
38**	800	398540891100																	
32**; 35**	1000	398532800100	175	75,0	97,0	12,71	4,5	6,3	19,04	95,2	24	35	23,0	38,10	28,0	48,0	124,0	67,0	5,5
36**; 37**	1000	398537901600																	
38**	1000	398540892400																	

Ø 125 - 1000 mm

Dystrybucja: unihurt.pl  
 Zamówienia: info@unihurt.pl





**SZCZĘKI GÓRNE TWARDE • 3597**  
 КУЛАЧКИ КАЛЕННЫЕ НАКЛАДНЫЕ • 3597

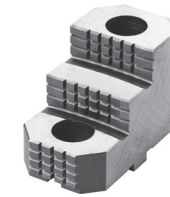

Uchwyt BISON	Wielkość uchwytu	Nr produktu	A	B	C	F	G	H	I	J	K	M	L	N	O	P	kg / szt.	
			Патрон BISON	Размер патрона	Код продукта	кг / шт.												
Ø 315 - 1000 mm	3597	160	398532830700	67	25	41,5	7,95	12,69	28,6	4	3,2	19,05	11	17	8,5	18	41,5	0,3
	3597	200	398532840900	80	27	43,5	7,95	12,69	34,9	4	3,2	22,25	11	17	9,5	20,5	50	0,4
	3597	250	398532850000	95	32,5	51,5	12,71	19,04	39,7	4	3,2	27	14	21	12	33,5	68	0,6
	3597	315	398538060400	110	37	55	12,7	19,04	47,6	4	3,2	31,75	14	21	13	26,5	68,0	0,9
	3597	405	398538104500	127	42	64,5	12,71	19,04	51,7	4	6,3	38,10	18	26	13,5	26,5	76,5	1,4
	3597	515	398538114700	127	42	74,5	12,71	19,04	51,7	4	6,3	38,10	22	33	17	51	89,0	1,6
	3597	660	398538127700	127	52	82	12,71	19,04	51,7	4	6,3	38,10	22	33	21	51	86,5	2,4
	3597	800	398538137900	127	52	82	12,71	19,04	51,7	4	6,3	38,10	22	33	21	51	89,0	2,3
	3597	1000	398532800100	175	75	97	12,71	19,04	95,2	4,5	6,3	38,10	24	35	28	50,5	75,8	5,6

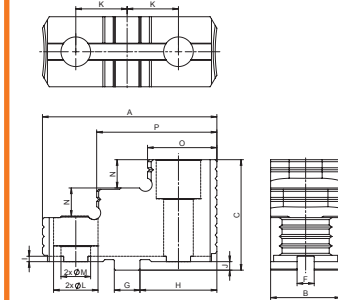

**SZCZĘKI GÓRNE TWARDE • HD**  
 КУЛАЧКИ КАЛЕННЫЕ НАКЛАДНЫЕ • HD

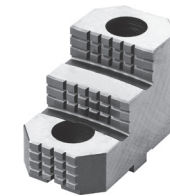

Uchwyt BISON	Nr produktu	A	B	C	F	G	H	I	J	K	M	L	N	O	P	kg / szt.	
		Патрон BISON	Код продукта	кг / шт.													
Ø 400 - 1000 mm	3515-16" HD	398532869700	135	54	82	12,71	19,04	57,1	4	6,3	38,1	22	33	21	54,5	88,0	2,45
	3515-20" HD	398532883400	135	54	82	12,71	19,04	57,1	4	6,3	38,1	22	33	21	54,7	87,6	2,45
	3515-25" HD	398532888800	135	75	97	12,71	19,04	57,1	4	6,3	38,1	24	35	28	56,6	59,5	4,10
	3515-32" HD	398532893600	135	75	97	12,71	19,04	57,1	4	6,3	38,1	24	35	28	56,3	59,1	4,10

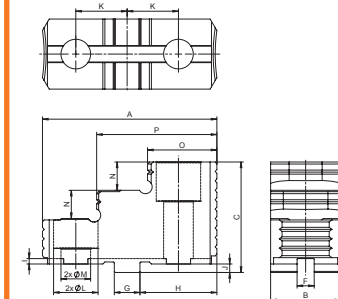

- 1
- 2
- 3
- 4
- 5
- 6
- 7

Distybuycja: unihurt.pl  
 Zamówienia: info@unihurt.pl  
 SGT



- 1
- 2
- 3
- 4
- 5
- 6
- 7
- A



**SZCZĘKI GÓRNE MIĘKKIE**  
 КУЛАЧКИ МЯГКИЕ НАКЛАДНЫЕ (СЫРЫЕ)

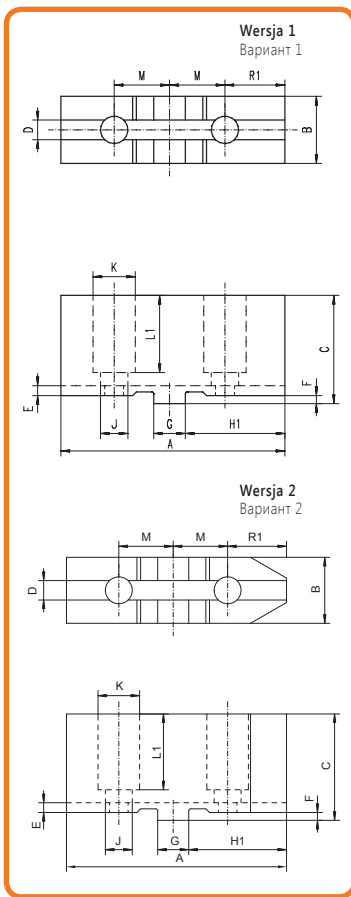

Uchwyt BISON	Wielkość uchwytu	Nr produktu	Wersja	A	B	C	D	E	F	G	H1	J	K	L <sub>1</sub>	M	kg / szt.	
																Патрон BISON	Размер патрона
32**; 35**	125	398533020600	1	64	22,0	38,5	7,95	4,0	3,2	12,69	25	9	15	26,0	16,00	0,3	
36**; 37**	125	398538220900															
38**	125	398540722000	2	64	22,0	38,5	7,95	4,0	3,2	12,69	25	6,6	11	26,0	16,00	0,3	
3105	160	398530530800			40,0												
32**; 35**	160	398533030800	1	78	25,0	41,5	7,95	4,0	3,2	12,69	34	11	18	29,0	19,05	0,5	
36**; 37**	160	398538230000															
38**	160	398540732200	2	78	25,0	41,5	7,95	4,0	3,2	12,69	34	9	14	29,0	19,05	0,5	
3105	200	398530540000	1	90	40,0	41,5	7,95	4,0	3,2	12,69	40	11	14	31,0	22,25	0,7	
32**; 35**	200	398533040000															
36**; 37**	200	398538240200	1	90	27,0	43,5	7,95	4,0	3,2	12,69	40	11	18	31,0	22,25	0,7	
38**	200	398540742400	2	90	27,0	43,5	7,95	4,0	3,2	12,69	40	9	14	31,0	22,25	0,7	
3105	250	398530550100			47												
32**; 35**	250	398533050100	1	106	32,5	51,5	12,71	4,0	3,2	19,04	45	14	20	38,0	27,00	1,2	
36**; 37**	250	398538250400															
38**	250	398540752600	2														
3105	315	398530560300			52,0												
32**; 35**	315	398533060300	1	120	37,0	55,0	12,71	4,0	3,2	19,04	53	14	20	40,0	31,75	1,6	
36**; 37**	315	398538260600															
38**	315	398540762800	2														
3105	400	398530570500			52,0												
32**; 35**	400	398533070500	1	140	42,0	64,5	12,71	4,0	6,3	19,04	63	18	26	45,5	38,10	2,2	
36**; 37**	400	398538270800															
38**	400	398540772000	2														
32**; 35**	500	398533080700															
36**; 37**	500	398538280000	1	140	42,0	74,5	12,71	4,0	6,3	19,04	63	22	33	56,0	38,10	2,4	
38**	500	398540780600															
32**; 35**	630	398533090900															
36**; 37**	630	398538290100	1	160	52,0	82,0	12,71	4,0	6,3	19,04	63	22	33	64,0	38,10	4,2	
38**	630	398540790800															
32**; 35**	800	398533090900															
36**; 37**	800	398538290100	1	160	52,0	82,0	12,71	4,0	6,3	19,04	63	22	33	64,0	38,10	4,2	
38**	800	398540790800															
32**; 35**	1000	398533093700															
36**; 37**	1000	398538292700	1	191	75,0	97,0	12,71	4,5	6,3	19,04	105	24	35	78,0	38,10	10,0	
38**	1000	398540700100															

Dystrybucja: unihurt.pl  
 Zamówienia: info@unihurt.pl



SZCZĘKI PODSTAWOWE  
 КУЛАЧКИ МАСТЕР (РЕЙКИ)

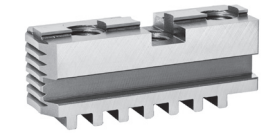

Uchwyt BISON	Wielkość uchwytu	Nr produktu	A	B	C	D	E	F	G	H	J	K	L	M	S	h	kg / szt.
																	kg / szt.
Патрон BISON	Размер патрона	Код продукта															кг / шт.
32**; 35**	125	398535720900	54	20	28,0	8,0	8	7,94	12,69	22,6	4,0	16,00	13,5	M8	3,2	7,0	0,1
36**; 37**	125	398539620000															
38**	125	398540920700	54	20	28,0	8,0	8	7,94	12,69	22,6	4,0	16,00	13,5	M6	3,2	7,0	0,1
3105	160	398530710600															
32**; 35**	160	398535730000	65	20	29,0	8,0	8	7,94	12,69	28,6	4,0	19,05	14,0	M10	3,2	8,0	0,2
36**; 37**	160	398539630200															
38**	160	398540930900	65	20	29,0	8,0	8	7,94	12,69	28,6	4,0	19,05	14,0	M8	3,2	8,0	0,2
3105	200	398530720800															
32**; 35**	200	398535740200	79	25	33,0	9,0	10	7,94	12,69	34,9	4,0	22,25	14,0	M10	3,2	8,0	0,3
36**; 37**	200	398539640400															
38**	200	398540940000	79	25	33,0	9,0	10	7,94	12,69	34,9	4,0	22,25	14,0	M8	3,2	8,0	0,3
3105	250	398530730000															
32**; 35**	250	398535750400															
36**; 37**	250	398539650600	92	28	36,0	11,0	12	12,7	19,04	39,7	4,0	27,00	16,0	M12	3,2	9,0	0,5
38**	250	398540950200															
3105	315	398530740100															
32**; 35**	315	398535760600															
36**; 37**	315	398539660800	110	32	40,0	12,7	12	12,7	19,4	47,6	4,0	31,75	16,0	M12	3,2	10,0	0,8
38**	315	398540960400															
3105	400	398530790000															
32**; 35**	400	398535770800															
36**; 37**	400	398539670000	130	36	49,0	15,0	14	12,7	19,04	57,1	7,2	38,10	22,0	M16	3,2	12,0	1,1
38**	400	398540970600															
32**; 35**	500	398535780000															
36**; 37**	500	398539680100	166	40	54,0	16,0	14	12,7	19,04	57,1	7,2	38,10	32,5	M20	3,2	14,2	2,2
38**	500	398540980800															
32**; 35**	630	398535790100															
36**; 37**	630	398539681400	210	50	54,5	16,0	14	12,7	19,04	57,1	7,2	38,10	32,5	M20	3,2	14,2	3,3
38**	630	398540990000															
32**; 35**	800	398535800600															
36**; 37**	800	398539682700	225	50	54,5	16,0	14	12,7	19,04	57,1	7,2	38,10	32,5	M20	3,2	14,2	3,4
38**	800	398540991200															
32**; 35**	1000	398532801400															
36**; 37**	1000	398539683000	328	70	64,0	22,0	20	12,7	19,04	57,1	7,2	38,10	36,0	M22	3,2	18,0	7,8
38**	1000	398540992500															

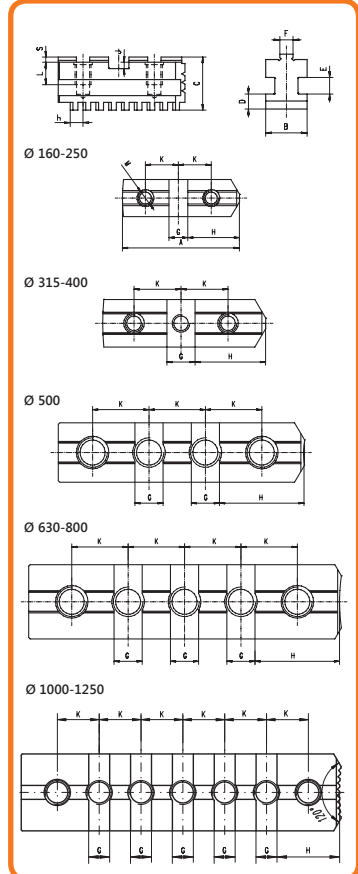





**SZCZĘKI PODSTAWOWE • 3295 I 3597**  
 КУЛАЧКИ МАСТЕР (РЕЙКИ) • 3295 И 3597

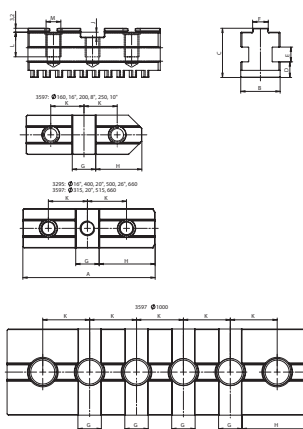

Uchwyt BISON	Wielkość uchwytu	Nr produktu	A	B	C	D	E	F	G	H	J	K	L	M	kg / szt.	
			Патрон BISON	Размер патрона	Код продукта											
Ø 315 - 1000 mm	3295	400	398539986000	120	36	49	15	14	12,7	19,04	57,1	7,2	38,1	22	M16	1,1
	3295	500	398539987300	120	40	54	16	14	12,7	19,04	57,1	7,2	38,1	32,5	M20	1,3
	3295	660	398539984500	127	50	54,5	16	14	12,7	19,04	54	7,2	38,1	32,5	M20	1,8
	3597	315	398538050200	107,5	32	40	12,7	12	12,7	19,04	45,1	4	31,75	20	M12	0,7
	3597	405	398539986000	120	36	49	15	14	12,7	19,04	57,1	7,2	38,1	22	M16	1,1
	3597	515	398539987300	120	40	54	16	14	12,7	19,04	57,1	7,2	38,1	32,5	M20	1,3
	3597	660	398538126400	127	50	54,5	16	14	12,7	19,04	57,1	7,2	38,1	32,5	M20	1,3
	3597	800	398538136600	160	50	54,5	16	14	12,7	19,04	57,1	7,2	38,1	32,5	M20	2,3
	3597	1000	398538146800	250	70	64	22	20	12,7	19,04	57,1	7,2	38,1	40	M22	6,1

**SZCZĘKI PODSTAWOWE • HD**  
 КУЛАЧКИ МАСТЕР (РЕЙКИ) • HD

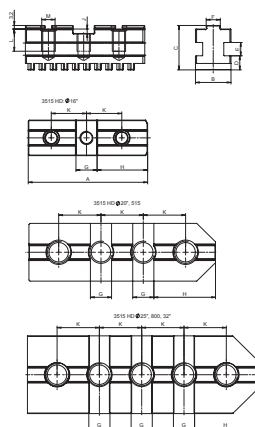

Uchwyt BISON	Nr produktu	A	B	C	D	E	F	G	H	J	K	L	M	kg / szt.	
		Патрон BISON	Код продукта												
Ø 400 - 800 mm	3515-16" HD	398535972500	132	50	54,5	16	14	12,7	19,04	57,1	7,2	38,1	32,5	3/4"	1,95
	3515-20" HD	398535982700	169	50	54,5	16	14	12,7	19,04	57,1	7,2	38,1	32,5	3/4"	2,50
	3515-25" HD	398535988300	210	70	62	20	20	12,7	19,04	57,1	7,2	38,1	33	7/8"	5,10
	3515-32" HD	398535995700	225	70	62	20	20	12,7	19,04	57,1	7,2	38,1	33	7/8"	5,50



Dystrybucja: unihurt.pl



Zamówienia: info@unihurt.pl

- 1
- 2
- 3
- 4
- 5
- 6
- 7
- A

SP 3597

SP HD



SZCZĘKI DZIELONE TWARDE ODWRACALNE  
КУЛАЧКИ СБОРНЫЕ КАЛЕННЫЕ ПЕРЕВОРАЧИВАЮЩИЕСЯ

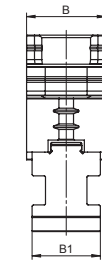
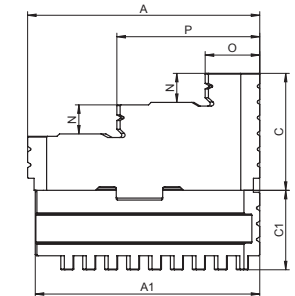

Uchwyt BISON	Wielkość uchwytu	Nr produktu	A	A1	B	B1	C	C1	N	O	P	kg / szt.
												Патрон BISON
32**; 35**	125	398535320500										
36**; 37**	125	398539220700	56	54	22,0	20	35,3	24,8	8,0	14,5	35,0	0,3
38**	125	398540320100										
32**; 35**	160	398535330700										
36**; 37**	160	398539230900	67	65	25,0	20	38,3	25,8	8,5	18,0	41,5	0,4
38**	160	398540330300										
32**; 35**	200	398535340900										
36**; 37**	200	398539240000	80	79	27,0	25	38,3	29,8	9,5	21,5	51,0	0,7
38**	200	398540340500										
32**; 35**	250	398535350000										
36**; 37**	250	398539250200	95	92	32,5	28	48,3	32,8	12,0	24,5	59,0	1,1
38**	250	398540350700										
32**; 35**	315	398535360200										
36**; 37**	315	398539260400	110	110	37,0	32	51,8	36,8	13,0	26,5	68,0	1,7
38**	315	398540360900										
32**; 35**	400	398535370400										
36**; 37**	400	398539270600	127	130	42,0	36	58,2	45,8	13,5	27,0	76,5	2,5
38**	400	398540370000										
32**; 35**	500	398535380600										
36**; 37**	500	398539280800	127	166	42,0	40	68,2	50,8	17,0	50,0	88,0	3,8
38**	500	398540380200										
32**; 35**	630	398535390800										
36**; 37**	630	398539290000	127	210	52,0	50	75,7	51,3	21,0	51,0	89,0	5,8
38**	630	398540390400										
32**; 35**	800	398535400200										
36**; 37**	800	398539291200	127	225	52,0	50	75,7	51,3	21,0	51,0	89,0	6,1
38**	800	398540391700										
32**; 35**	1000	398535401500										
36**; 37**	1000	398539292500	175	328	75,0	70	90,7	60,8	28,0	48,0	124	14,0
38**	1000	398540392000										

Ø 125 - 1000 mm

- 1
- 2
- 3
- 4
- 5
- 6
- 7

Dystrybucja: [unihurt.pl](mailto:unihurt.pl)

Zamówienia: [info@unihurt.pl](mailto:info@unihurt.pl)

IDS



**SZCZĘKI DZIELONE TWARDE ODWRACALNE • 3597**  
 КУЛАЧКИ СБОРНЫЕ КАЛЕННЫЕ ПЕРЕВОРАЧИВАЮЩИЕСЯ • 3597

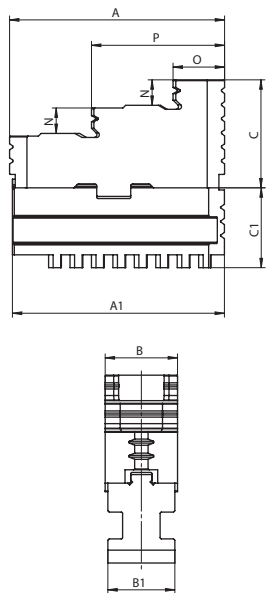

Uchwyt BISON	Wielkość uchwytu	Nr produktu	A	A1	B	B1	C	C1	N	O	P	kg / szt.	
												Патрон BISON	Размер патрона
Ø 315 - 1000 mm	3597	315	398538070600	110	107,5	37	32	51,8	36,8	13	26,5	68	1,7
	3597	405	398538102000	127	120	42	36	58,2	45,8	13,5	26,5	76,5	2,7
	3597	515	398538111900	127	120	42	40	68,2	50,8	17	51	89	3,2
	3597	660	398538125100	127	127	52	50	75,8	51,3	21	51	86,5	4,6
	3597	800	398538135300	127	160	52	50	75,8	51,3	21	51	89	5,1
	3597	1000	398538145500	175	250	75	70	90,7	60,8	28	50,5	75,5	12,1

**SZCZĘKI DZIELONE TWARDE ODWRACALNE • HD**  
 КУЛАЧКИ СБОРНЫЕ КАЛЕННЫЕ ПЕРЕВОРАЧИВАЮЩИЕСЯ • HD

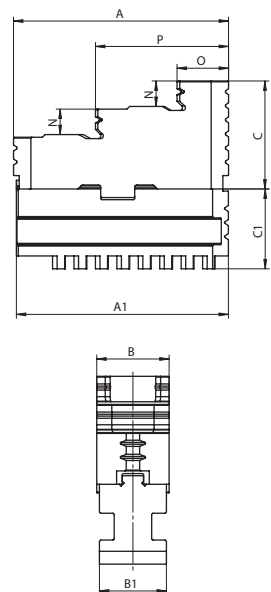

Uchwyt BISON	Wielkość uchwytu	A	A1	B	B1	C	C1	N	O	P	kg / szt.	
											Патрон BISON	Размер патрона
Ø 400 - 800 mm	3515-16" HD	398535471800	135	132	54	50	75,7	51,3	21	54,5	88	4,76
	3515-20" HD	398535478700	135	169	54	50	75,7	51,3	21	54,7	87,6	5,30
	3515-25" HD	398535489100	135	210	75	70	83,7	58,8	28	56,6	89,5	9,96
	3515-32" HD	398535497800	135	225	75	70	83,7	58,8	28	56,3	89,1	9,96



Dystrybucja: unihurt.pl  
 Zamówienia: info@unihurt.pl

- 1
- 2
- 3
- 4
- 5
- 6
- 7
- A

SDT 3597

SDT HD



SZCZĘKI DZIELONE MIĘKKIE  
КУЛАЧКИ СБОРНЫЕ МЯГКИЕ

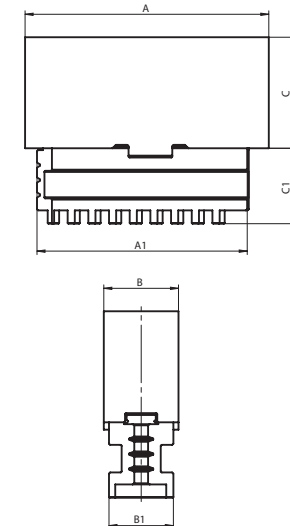
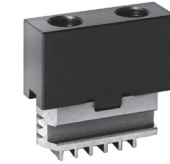

Uchwyt BISON	Wielkość uchwytu	Nr produktu	A	A1	B	B1	C	C1	kg / szt.
									кг / шт.
Патрон BISON	Размер патрона	Код продукта							
32**, 35**	125	398535520700							
36**, 37**	125	398539420900	64	54	22,0	20	35,3	24,8	0,4
38**	125	398540521600							
3105	160	398530010000							
32**, 35**	160	398535530900	78	65	25,0	20	38,3	25,8	0,6
36**, 37**	160	398539430000							
38**	160	398540531800							
3105	200	398530020100							
32**, 35**	200	398535540000	90	79	27,0	25	38,3	29,8	1,0
36**, 37**	200	398539440200							
38**	200	398540541000							
3105	250	398530030300							
32**, 35**	250	398535550200	106	92	32,5	28	48,3	32,8	1,6
36**, 37**	250	398539450400							
38**	250	398540551100							
3105	315	398530040500							
32**, 35**	315	398535560400	120	110	37,0	32	51,8	36,8	3,1
36**, 37**	315	398539460600							
38**	315	398540561300							
3105	400	398530110000							
32**, 35**	400	398535570600	140	130	42,0	36	58,2	45,8	3,3
36**, 37**	400	398539470800							
38**	400	398540571500							
32**, 35**	500	398535580800							
36**, 37**	500	398539480000	140	166	42,0	40	68,2	50,8	4,6
38**	500	398540580400							
32**, 35**	630	398535590000							
36**, 37**	630	398539490100	160	210	52,0	50	75,7	51,3	7,5
38**	630	398535601700							
32**, 35**	800	398535600400							
36**, 37**	800	398539491400	160	225	52,0	50	75,7	51,3	7,6
38**	800	398535602000							
32**, 35**	1000	398535611900							
36**, 37**	1000	398539492700	191	328	75,0	70	90,7	60,8	17,8
38**	1000	398535603200							



**SZCZĘKI JEDNOLITE TWARDE ZEWNĘTRZNE • CT**  
КУЛАЧКИ ПРЯМЫЕ ЦЕЛЬНЫЕ КАЛЕННЫЕ • СТ

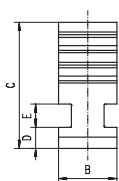
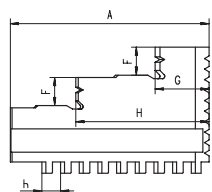
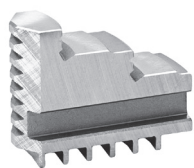

Uchwyt BISON	Wielkość uchwytu	Nr produktu	A	B	C	D	E	F	G	H	h	kg / szt.
												кг / шт.
СТОО; СТОО F; СТ74; 3204-СТ; 3234-СТ	80	398535000900	32	11	28	6	6	6	9,5	21,0	4	0,03
СТОО; СТОО F; СТ74; 3204-СТ; 3234-СТ	100	398535010000	42	15	32	6	6	7	11,0	27,0	6	0,09
СТОО; СТОО F; СТ74; 3204-СТ; 3234-СТ	125	398535020200	51	20	40	8	8	8	13,0	33,5	7	0,18
СТОО; СТОО F; СТ74; 3204-СТ; 3234-СТ	160	398535030400	70	20	53	8	8	10	19,0	45,0	8	0,36
СТОО; СТОО F; СТ74; 3204-СТ; 3234-СТ	200	398535040600	85	25	54	9	10	12	23,0	57,0	8	0,5
СТОО; СТОО F; СТ74; 3204-СТ; 3234-СТ	250	398539090800	105	28	63	11	12	14	28,0	69,5	10	0,8
СТОО; СТОО F; СТ74; 3204-СТ; 3234-СТ	315	398535060000	125	32	73	12,7	12	18	34,5	83,0	10	1,32
СТОО; СТОО F; СТ74; 3204-СТ; 3234-СТ	400	398535070100	145	36	92	15	14	22	36,0	99,0	12	2,35

**SZCZĘKI JEDNOLITE TWARDE WEWNTRZNE • CT**  
КУЛАЧКИ ОБРАТНЫЕ ЦЕЛЬНЫЕ КАЛЕННЫЕ • СТ

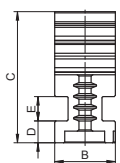
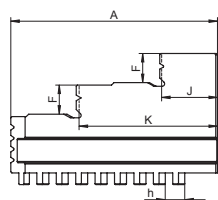
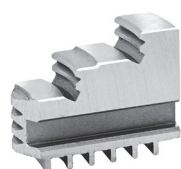

Uchwyt BISON	Wielkość uchwytu	Nr produktu	A	B	C	D	E	F	J	K	h	kg / szt.
												кг / шт.
СТОО; СТОО F; СТ74; 3204-СТ; 3234-СТ	80	398535100000	32	11	28	6,0	6	6	9,5	21,0	4	0,03
СТОО; СТОО F; СТ74; 3204-СТ; 3234-СТ	100	398535110100	42	15	32	6,0	6	7	12,0	27,5	6	0,09
СТОО; СТОО F; СТ74; 3204-СТ; 3234-СТ	125	398535120300	51	20	40	8,0	8	8	13,0	33,5	7	0,18
СТОО; СТОО F; СТ74; 3204-СТ; 3234-СТ	160	398535130500	70	20	53	8,0	8	10	22,0	47,5	8	0,36
СТОО; СТОО F; СТ74; 3204-СТ; 3234-СТ	200	398535140700	85	25	54	9,0	10	12	23,0	57,0	8	0,50
СТОО; СТОО F; СТ74; 3204-СТ; 3234-СТ	250	398535220400	105	28	63	11,0	12	14	28,0	69,5	10	0,80
СТОО; СТОО F; СТ74; 3204-СТ; 3234-СТ	315	398535160000	125	32	73	12,7	12	18	34,5	83,0	10	1,32
СТОО; СТОО F; СТ74; 3204-СТ; 3234-СТ	400	398535170200	145	36	92	15,0	14	22	36,0	99,0	12	2,35



1

2

3

4

5

6

7

A

SJZ CT

SJW CT





SZCZĘKI PODSTAWOWE - CT  
 КУЛАЧКИ МАСТЕР (РЕЙКИ) - СТ

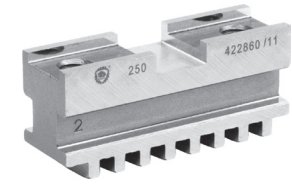

Uchwyt BISON	Wielkość uchwytu	Nr produktu	A <sup>+0,8</sup>	B <sup>+0,5</sup>	C	E	K	M	h	kg / szt.
										кг / шт.
Патрон BISON	Размер патрона	Код продукта								
CTOO; CTOO F; CT74; 3204-CT; 3234-CT	160	398535830100	5	3	12	12	40	2xM8	8	0,18
CTOO; CTOO F; CT74; 3204-CT; 3234-CT	200	398535840300	5	3	15	15	50	2xM10	8	0,3
CTOO; CTOO F; CT74; 3204-CT; 3234-CT	250	398535850500	7	3	20	20	65	2xM12	10	0,48
CTOO; CTOO F; CT74; 3204-CT; 3234-CT	315	398535860700	8	4	20	20	80	2xM12	10	0,77
CTOO; CTOO F; CT74; 3204-CT; 3234-CT	400	398535870900	9	4	25	25	95	2xM16	12	1,10

Ø 315 - 1000 mm

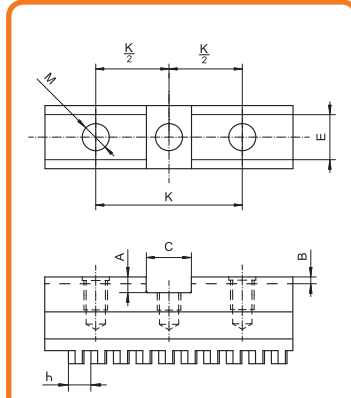

- 1
- 2
- 3
- 4
- 5
- 6
- 7

Dystrybucja: [unihurt.pl](http://unihurt.pl)  
 Zamówienia: [info@unihurt.pl](mailto:info@unihurt.pl) 1 SP CT

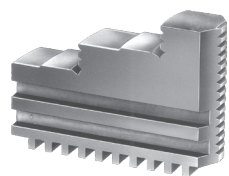

**SZCZĘKI JEDNOLITE TWARDE ZEWNĘTRZNE**  
КУЛАЧКИ ПРЯМЫЕ ЦЕЛЬНЫЕ КАЛЕННЫЕ

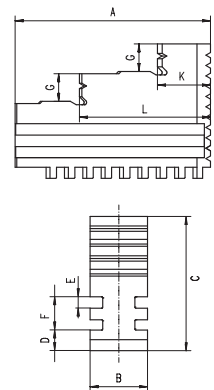

Uchwyt BISON	Wielkość uchwytu	Nr produktu	A	B	C	D	E	F	G	K	L	kg / szt.
												кг / шт.
3202; 3203	160	398533610000	70	20	56	8,0	6	18	12	19	45,0	0,5
3602; 3603	160	398536810600										0,5
3202; 3203	200	398533620100	85	25	62	9,0	6	18	12	23	57,0	0,6
3602; 3603	200	398536820800										0,6
3202; 3203	250	398533630300	105	28	74	11,0	8	23	15	28	69,5	1,1
3602; 3603	250	398536830000										1,1
3202; 3203	315	398533640500	125	32	90	12,7	10	29	19	34	83,0	1,7
3602; 3603	315	398536840100										1,7
3202; 3203	400	398533650700	145	36	107	15,0	10	29	22	36	99,0	2,7
3602; 3603	400	398536850300										2,7
3202; 3203	500	398533660900	180	40	120	16,0	12	34	26	50	119,5	4,9
3602; 3603	500	398536851600										4,9
3202; 3203	630	398533670000	225	50	130	16,0	12	34	28	66	149,0	7,7
3602; 3603	630	398536852900										7,7

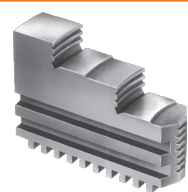

**SZCZĘKI JEDNOLITE TWARDE WEWNĘTRZNE**  
КУЛАЧКИ ОБРАТНЫЕ ЦЕЛЬНЫЕ КАЛЕННЫЕ

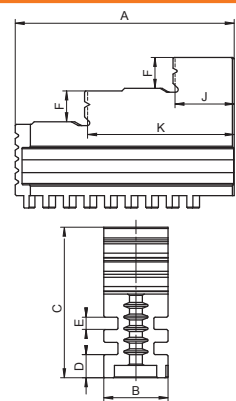

Uchwyt BISON	Wielkość uchwytu	Nr produktu	A	B	C	D	E	F	G	J	K	kg / szt.
												кг / шт.
3202; 3203	160	398533710000	70	20	56	8,0	6	18	12	23	45,0	0,5
3602; 3603	160	398536860500										0,5
3202; 3203	200	398533720200	85	25	62	9,0	6	18	12	23	57,0	0,6
3602; 3603	200	398536870700										0,6
3202; 3203	250	398533730400	105	28	74	11,0	8	23	15	28	69,5	1,1
3602; 3603	250	398536880900										1,1
3202; 3203	315	398533740600	125	32	90	12,7	10	29	19	34	83,0	1,7
3602; 3603	315	398536890000										1,7
3202; 3203	400	398533750800	145	36	107	15,0	10	29	22	36	99,0	2,7
3602; 3603	400	398536800500										2,7
3202; 3203	500	398533760000	180	40	120	16,0	12	34	26	50	119,5	4,9
3602; 3603	500	398536901800										4,9
3202; 3203	630	398533770100	180	40	120	16,0	12	34	26	66	119,5	4,9
3602; 3603	630	398536902000										4,9





SZCZĘKI JEDNOLITE MIĘKKIE  
 КУЛАЧКИ МЯГКИЕ ЦЕЛЫЕ

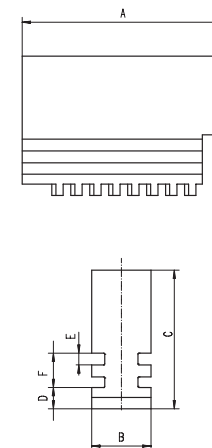
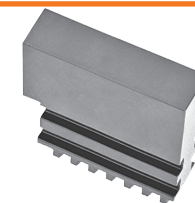

Uchwyt BISON	Wielkość uchwytu	Nr produktu	A	B	C	D	E	F	kg / szt.
									кг / шт.
Патрон BISON	Размер патрона	Код продукта							
3202; 3203	160	398533110500	70	20	56	8,0	6	18	0,5
3602; 3603	160	398537110800							
3202; 3203	200	398533120700	85	25	62	9,0	6	18	0,6
3602; 3603	200	398537120000							
3202; 3203	250	398533130900	105	28	74	11,0	8	23	1,1
3602; 3603	250	398537130100							
3202; 3203	315	398533140000	125	32	90	12,7	10	29	1,7
3602; 3603	315	398537140300							
3202; 3203	400	398533150200	145	36	107	15,0	10	29	3,8
3602; 3603	400	398537150500							
3202; 3203	500	398533160400	180	40	120	16,0	12	34	8,8
3602; 3603	500	398537160700							
3202; 3203	630	398533170600	225	50	130	16,0	12	34	10,2
3602; 3603	630	398537170900							

Ø 160 - 630 mm

- 1
- 2
- 3
- 4
- 5
- 6

7

Dystrybucja: [unihurt.pl](mailto:unihurt.pl)  
 Zamówienia: [info@unihurt.pl](mailto:info@unihurt.pl)

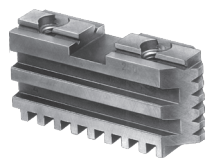

**SZCZĘKI PODSTAWOWE**  
 КУЛАЧКИ МАСТЕР (РЕЙКИ)

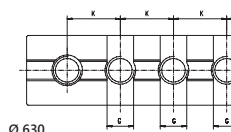
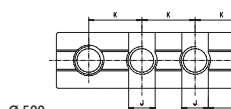
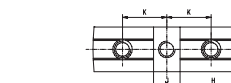
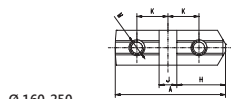
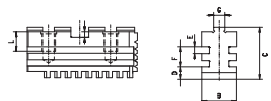

Uchwyt BISON	Wielkość uchwytu	Nr produktu	A	B	C	D	E	F	G	H	J	K	L	M	kg / szt.
Патрон BISON	Размер патрона	Код продукта													кг / шт.
3202; 3203	160	398533810100	65	20	39	8,0	6	18	7,94	28,6	12,69	19,05	15,0	2xM10	0,3
3602; 3603	160	398536910700													
3202; 3203	200	398533820300	79	25	41	9,0	6	18	7,94	34,9	12,69	22,25	14,0	2xM10	0,4
3602; 3603	200	398536920900													
3202; 3203	250	398533830500	92	28	47	11,0	8	23	12,7	39,7	19,04	27,00	16,0	2xM10	0,6
3602; 3603	250	398536930000													
3202; 3203	315	398533840700	110	32	57	12,7	10	29	12,7	47,6	19,04	31,75	16,0	3xM12	1,1
3602; 3603	315	398536940200													
3202; 3203	400	398533850900	130	36	64	15,0	10	29	12,7	57,1	19,04	38,10	18,8	3xM16	1,6
3602; 3603	400	398536950400													
3202; 3203	500	398533860000	166	40	74	16,0	12	34	12,7	57,1	19,04	38,10	32,5	4xM20	2,6
3602; 3603	500	398536960600													
3202; 3203	630	398533800000	210	50	74	16,0	12	34	12,7	57,1	19,04	38,10	32,5	5xM20	3,8
3602; 3603	630	398536961900													

Ø 160 - 630 mm

Dystrybucja: unihurt.pl



Zamówienia: info@unihurt.pl



**SZCZĘKI JEDNOLITE TWARDE ZEWNĘTRZNE**  
 КУЛАЧКИ ПРЯМЫЕ ЦЕЛЬНЫЕ КАЛЕННЫЕ

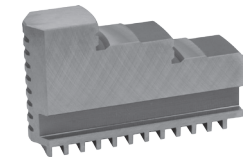

Ø 125 - 315 mm	Uchwyt RÖHM	Nr produktu	A	B	C	D	E	F	G	H	kg / szt.
	Патрон RÖHM	Код продукта									кг / шт.
	ZG-125/3; ZS-125/3	398531730800	52	18	41,5	7,3	7	8	17	35	0,2
	ZG-140/3; ZS-140/3	398531740000	61	18	41,5	8,2	7	8	18	40	0,2
	ZG-160/3; ZS-160/3	398531750100	61	18	47,5	8,2	7	10	18	40	0,2
	ZG-200/3; ZS-200/3	398531760300	69	20	53,5	8,2	8	10	20	44	0,4
	ZG-250/3; ZS-250/3	398531780700	90	24	67,5	10,3	10	14	27	57	0,7
	ZG-315/3; ZS-315/3	398531800300	130	34	79,5	11,2	15	15	41,5	86,5	1,8

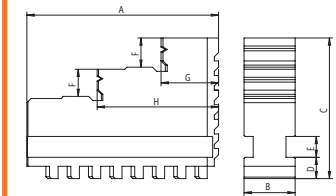

**SZCZĘKI JEDNOLITE TWARDE WEWNĘTRZNE**  
 КУЛАЧКИ ОБРАТНЫЕ ЦЕЛЬНЫЕ КАЛЕННЫЕ

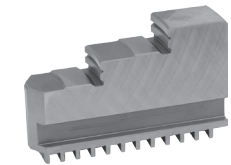

Ø 125 - 315 mm	Uchwyt RÖHM	Nr produktu	A	B	C	D	E	F	G	H	kg / szt.
	Патрон RÖHM	Код продукта									кг / шт.
	ZG-125/3; ZS-125/3	398531870600	52	18	41,5	7,3	7	8	16	34	0,2
	ZG-140/3; ZS-140/3	398531880800	61	18	41,5	8,2	7	8	17	39	0,2
	ZG-160/3; ZS-160/3	398531890000	61	18	47,5	8,2	7	10	17	39	0,2
	ZG-200/3; ZS-200/3	398531900400	69	20	53,5	8,2	8	10	19	43	0,4
	ZG-250/3; ZS-250/3	398531920800	90	24	67,5	10,3	10	14	26	56	0,7
	ZG-315/3; ZS-315/3	398531940100	130	34	79,5	11,2	15	15	40	85	1,8

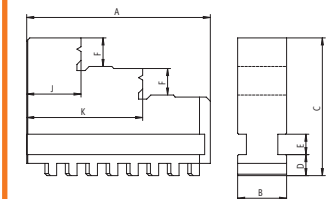

- 1
- 2
- 3
- 4
- 5
- 6
- 7

Dystrybucja: unihurt.pl  
  
 Zamówienia: info@unihurt.pl  
 SJWR MRS



SZCZĘKI JEDNOLITE MIĘKKE  
 КУЛАЧКИ МЯГКИЕ ЦЕЛЬНЫЕ

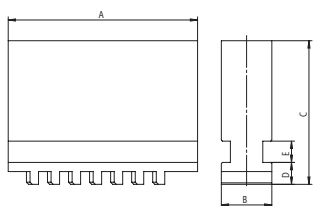
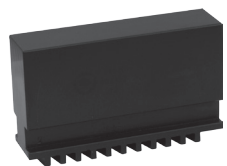

Uchwyt RÖHM Патрон RÖHM	Nr produktu Код продукта	A	B	C	D	E	kg / szt. кг / шт.
ZG-80/3; ZS-80/3	398538320000	37	12	26	4,8	4,5	0,1
ZG-100/3; ZS-100/3	398538301900	48	14	33,5	6,3	6	0,2
ZG-110/3; ZS-110/3	398538301900	48	14	33,5	6,3	6	0,2
ZG-125/3; ZS-125/3	398538302100	52	18	41,5	7,3	7	0,3
ZG-140/3; ZS-140/3	398538303400	61	18	41,5	8,2	7	0,3
ZG-160/3; ZS-160/3	398538304700	61	18	47,5	8,2	7	0,4
ZG-200/3; ZS-200/3	398538305000	69	20	53,5	8,2	8	0,5
ZG-250/3; ZS-250/3	398538306200	90	24	67,5	10,3	10	1,0
ZG-315/3; ZS-315/3	398538307500	130	34	79,5	11,2	15	2,4

Ø 80 - 315 mm







**SZCZĘKI GÓRNE TWARDE**  
 КУЛАЧКИ КАЛЕННЫЕ НАКЛАДНЫЕ

Ø 125 - 315 mm	Uchwyt RÖHM	Nr produktu	A	B	C	D	F	G	H	J	K	L	M	N	O	P	R	kg / szt.
	Патрон RÖHM	Код продукта																кг / шт.
	ZG-125/3; ZS-125/3	398537710300	56	26	37,5	7,96	3,1	12,68	22,6	9	15	9	16	8	13	35	13	0,2
	ZG-140/160/3; ZS-140/160/3	398537720500	66,7	28	41,5	7,96	3,1	12,68	28,5	9	15	10	19,05	10	15,8	42,8	15,8	0,3
	ZG-200/230/3; ZS-200/230/3	398537730700	79,5	30	42,5	7,96	3,1	12,68	34,9	9	15	10	22,23	10	19	51,5	19	0,4
	ZG-250/270/3; ZS-250/270/3	398537740900	95,3	36	52,5	12,72	3,1	19,03	39,7	14	20	13,5	26,98	14	22,2	60,2	22,2	0,7
	ZG-315/3; ZS-315/3	398537750000	109,5	42	57,5	12,72	3,1	19,03	47,6	14	20	13,5	31,75	15	25,4	67,4	25,4	1,0

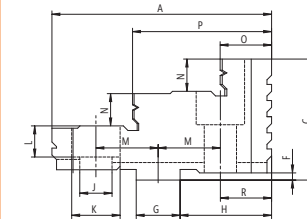
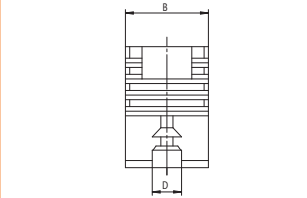

**SZCZĘKI GÓRNE MIĘKKIE**  
 КУЛАЧКИ МЯГКИЕ НАКЛАДНЫЕ (СЫРЫЕ)

Ø 125 - 800 mm	Uchwyt RÖHM	Nr produktu	Typ szczęk	N	S	B	H <sub>1</sub>	H <sub>2</sub>	L	b	l	Śruby	kg / szt.
	Патрон RÖHM	Код продукта	Тип кулачков									Винты	кг / шт.
	ZGU 125; ZSU 125; ZGF 125	398525426500	SGM Z4PS 125-01	7,96	12,67	26	38	35,0	62	32,0	25,6	M 8	0,4
	ZGU 160; ZGU 140; ZSU 160; ZSU 140; ZGF 160	398525427800	SGM Z4PS 160-01	7,96	12,67	30	45	42,0	74	38,1	32,2	M 8	0,6
	ZGU 200; ZGD 200-230; ZSU 200; UGU 200; ZGF 250; USU 260	398525428000	SGM Z4PS 200-01	7,96	12,67	30	50	47,0	87	44,5	38,7	M 8	0,8
	ZGU 250; ZGD 250-270; ZSU 250; UGU 260; ZGF 250; USU 260	398525429300	SGM Z4PS 250-01	12,72	19,02	35	60	57,0	103	54,0	43,5	M 12	1,3
		398525430000	SGM Z4PS 250-10	12,72	19,02	50	60	57,0	118	54,0	40,5	M 16	2,2
		398525431300	SGM Z4PS 315-10	12,72	19,02	50	60	53,7	137	63,5	47,5	M 16	2,5
	ZGU 315; ZGD 315; ZSU 315; UGU 310-350; ZGF 350-400; USU 400-450	398525432600	SGM Z4PS 315-01	12,72	19,02	40	60	57,0	120	63,5	53,0	M 12	1,8
	ZGU 350-400; ZGD 400; ZSU 350-400; UGU 400-450; ZGF 350-400; USU 400-450	398525433900	SGM Z4PS 350-01	12,72	19,02	50	80	73,7	137	76,2	62,0	M 16	3,4
	ZGU 500-630-700; ZGD 500; ZSU 500-630-700; UGU 500-560-600-630-710; USU 500-560-600-630-710	398525434100	SGM Z4PS 500-01	12,72	19,02	50	80	73,7	140	76,2	63,5	M 20	3,2
	HS 630-700-800; ZGU 800; ZSU 800; UGU 800; USU 800; HS 1000-1250; ZGU 1000-1250; ZSU 1000-1250	398525435400	SGM Z4PS 800-01	12,72	19,02	60	100	93,7	210	76,2	70,0	M 20	8,0

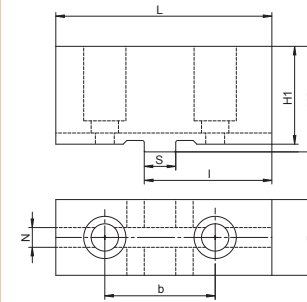

- 1
- 2
- 3
- 4
- 5
- 6
- 7

Dystrybucja: unihurt.pl  
  
 Zamówienia: info@unihurt.pl  
**SGM R** | unihurt.pl



SZCZĘKI PODSTAWOWE  
 КУЛАЧКИ МАСТЕР (РЕЙКИ)

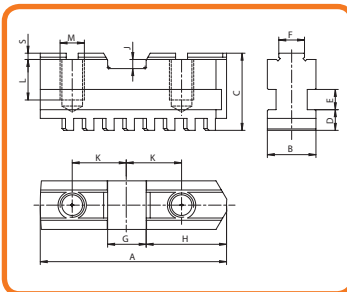

Uchwyt RÖHM	Nr produktu	A	B	C	D	E	F	G	H	J	K	L	M	S	kg / szt.
															кг / шт.
Patron RÖHM	Код продукта														
ZG-125/3; ZS-125/3	398535711000	55	18	27,1	7,3	7	7,94	12,69	22,6	4,5	16	14,5	M8	3,1	0,1
ZG-140/3; ZS-140/3	398535712200	65	18	30,1	8,2	7	7,94	12,69	28,5	4,5	19,05	16	M8	3,1	0,2
ZG-160/3; ZS-160/3	398535713500	65	18	30,1	8,2	7	7,94	12,69	28,5	4,5	19,05	16	M8	3,1	0,2
ZG-200/3; ZS-200/3	398535714800	78	20	31,1	8,2	8	7,94	12,69	34,9	4,5	22,225	16	M8	3,1	0,2
ZG-250/3; ZS-250/3	398535715000	92	24	38,1	10,2	10	12,7	19,04	39,7	4,5	27	20	M12	3,1	0,4
ZG-315/3; ZS-315/3	398535716300	108	34	43,1	11,2	15	12,7	19,04	47,6	4,5	31,75	25	M12	3,1	0,8

Ø 125 - 315 mm

- 1
- 2
- 3
- 4
- 5
- 6
- 7
- A

Dystrybucja: unihurt.pl  
 Zamówienia: info@unihurt.pl

SP



**SZCZĘKI JEDNOLITE TWARDE**  
 КУЛАЧКИ ЦЕЛЬНЫЕ КАЛЕННЫЕ

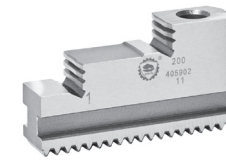

Uchwyt BISON	Wielkość uchwytu	Nr produktu												kg / szt.	
			A	B	C	D	E	F	G	H	J	a	b		
Патрон BISON	Размер патрона	Код продукта												кг / шт.	
Ø 125 - 315 mm	34**	125	398530910800	58,0	14	40	6,5	7	7,0	16,0	32,0	48	8	12	0,4
	34**	160	398530920000	69,0	20	45	7,5	9	8,0	26,0	58,0	-	10	12	1,0
	34**	200	398530930100	90,0	22	50	8,0	9	11,5	33,0	72,5	-	12	15	1,5
	34**	250	398530940300	108,5	26	60	10,0	11	14,0	36,0	83,0	-	15	20	2,6
	34**	315	398530950500	132,0	32	70	12,0	14	17,0	41,5	104,5	-	20	20	4,4

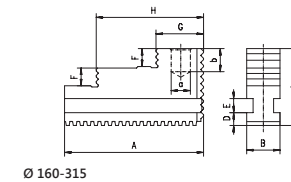
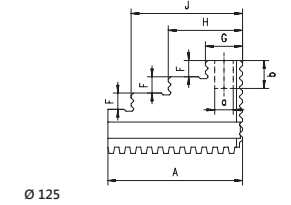

**SZCZĘKI PODSTAWOWE**  
 КУЛАЧКИ МАСТЕР (РЕЙКИ)



Uchwyt BISON	Wielkość uchwytu	Nr produktu																	kg / szt.		
			A	B	C	D	E	F	G	H	J	K	L	M	N	O	P	R		S	
Патрон BISON	Размер патрона	Код продукта																	кг / шт.		
Ø 125 - 315 mm	34**	125	398531081300	59	20	36,0	14	1,5	5,0	5	26,0	6,4	10,4	6,0	10	7,0	16,0	31	18,5	47	0,2
	34**	160	398531082600	63	20	32,5	8	3,0	4,5	18	23,0	8,4	13,5	9,0	16	7,5	26,0	39	16,0	-	0,2
	34**	200	398531083900	72	22	38,5	10	3,5	5,0	20	27,0	8,4	13,5	9,0	20	9,5	32,0	48	17,0	-	0,3
	34**	250	398531084100	90	30	50,0	12	3,5	5,0	20	30,0	13,0	19,0	7,0	20	14,0	40,5	81	20,0	-	0,7
	34**	315	398531085400	105	35	53,5	12	3,5	6,5	26	35,3	13,0	19,0	15,5	27	15,0	40,0	95	21,3	-	1,1

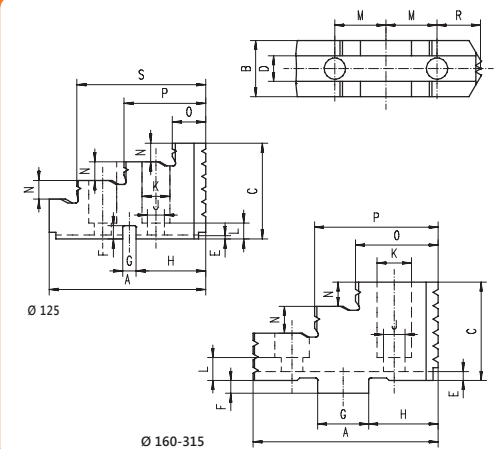

Ø 160-315



**SZCZĘKI GÓRNE MIĘKKIE**  
 КУЛАЧКИ МЯГКИЕ НАКЛАДНЫЕ (СЫРЫЕ)

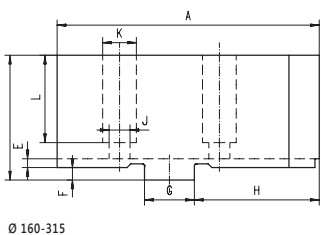
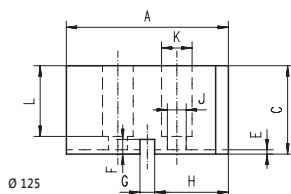
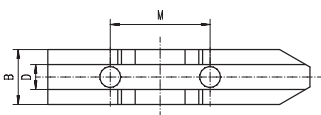

Uchwyt BISON	Wielkość uchwytu	Nr produktu	A	B	C	D	E	F	G	H	J	K	L	M	kg / szt.	
			Патрон BISON	Размер патрона	Код продукта	кг / шт.										
Ø 125 - 315 mm	34**	125	398531030100	55	20	30	14	1,5	5,0	5	25	6,4	10,4	24,0	20	0,2
	34**	160	398531040300	85	20	40	8	3,0	4,5	18	42	8,4	13,5	26,5	32	0,4
	34**	200	398531050500	105	22	50	10	3,5	5,0	20	50	8,4	13,5	35,0	40	0,7
	34**	250	398531060700	125	30	55	12	3,5	5,0	20	70	13,0	19,0	41,0	40	1,2
	34**	315	398531070900	145	35	60	12	3,5	6,0	26	74	13,0	19,0	38,0	54	1,8



1

2

3

4

5

6

7

A



**SZCZĘKI PODSTAWOWE**  
 КУЛАЧКИ МАСТЕР (РЕЙКИ)

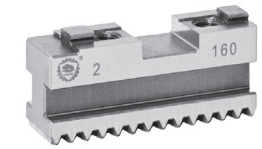

Uchwyt BISON	Wielkość uchwytu	Nr produktu	A	B	C	D	E	F	G	H	J	K	L	M	S	kg / szt.	
																кг / шт.	
Патрон BISON	Размер патрона	Код продукта															
Ø 125 - 315 mm	34**	125	398530970900	51,5	14	21,5	6,5	7	-	5	25,75	3,0	10	10	M6	-	0,1
	34**	160	398530980000	65,0	20	30,0	7,5	9	8	18	28,0	5,0	32	13	M8	2,5	0,2
	34**	200	398530990200	85,0	22	32,0	8,0	9	10	20	42,0	5,5	40	13	M8	2,5	0,3
	34**	250	398531000600	87,5	26	40,0	10,0	11	12	20	41,5	5,5	40	15	M12	3,0	0,5
	34**	315	398531010800	125,0	32	46,0	12,0	14	12	26	69,0	7,0	54	17	M12	3,0	1,0

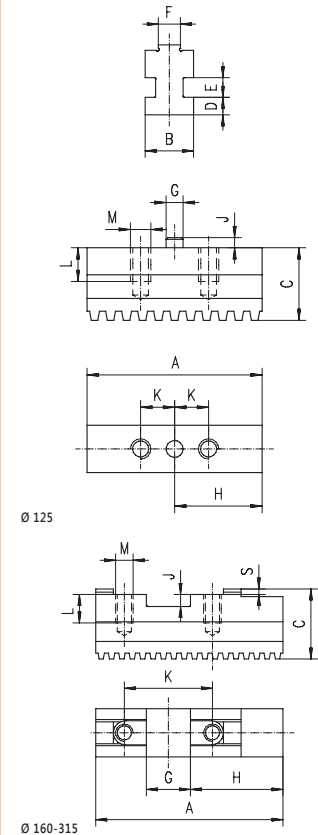

- 1
- 2
- 3
- 4
- 5
- 6

7

Дистрибуция: [unihurt.pl](mailto:unihurt.pl)  
 Zamówienia: [info@unihurt.pl](mailto:info@unihurt.pl)

PS



**СЗСЗКІ ДЗІЕЛОНЕ ТВАРДЕ ОДВРАСАЛНЕ**  
 КУЛАЧКИ СБОРНІЕ КАЛЕНІЕ ПЕРЕВІРАСАВАЮААІЕСЯ

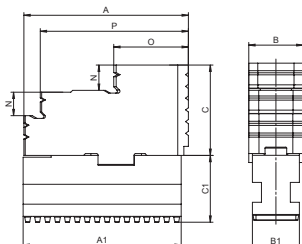

Ø 125 - 315 mm	Uchwyt BISON	Wielkość uchwytu	Nr produktu	A	A1	B	B1	C	C1	N	O	P	kg / szt.
	Патрон BISON	Размер патрона	Код продукта										кг / шт.
	34**	125	398531210000	59	51,5	20	14	36,0	21,5	7,0	16,0	31	0,3
	34**	160	398531220100	63	65,0	20	20	32,5	27,5	7,5	26,0	39	0,4
	34**	200	398531230300	72	85,0	22	22	38,5	29,5	9,5	32,0	48	0,6
	34**	250	398531240500	90	87,5	30	26	50,0	37,0	14,0	40,5	81	1,2
	34**	315	398531250700	105	125,0	35	32	53,5	43,0	15,0	40,0	95	2,1

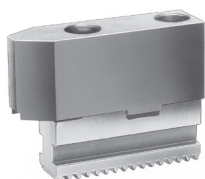

**СЗСЗКІ ДЗІЕЛОНЕ МІІККІЕ**  
 КУЛАЧКИ СБОРНІЕ МЯГКІЕ

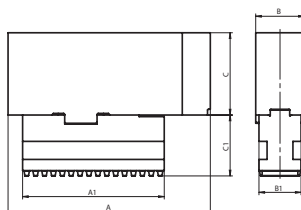

Ø 125 - 315 mm	Uchwyt BISON	Wielkość uchwytu	Nr produktu	A	A1	B	B1	C	C1	kg / szt.
	Патрон BISON	Размер патрона	Код продукта							кг / шт.
	34**	125	398531270000	55	51,5	20	14	30,0	21,5	0,3
	34**	160	398531280200	85	65,0	20	20	35,5	27,5	0,6
	34**	200	398531290400	105	85,0	22	22	45,0	29,5	1,0
	34**	250	398531292000	125	87,5	30	26	50,0	37,0	1,7
	34**	315	398531294500	145	125,0	35	32	54,0	43,0	2,8

Dystrybucja: unihurt.pl  
 Zamówienia: info@unihurt.pl

1  
2  
3  
4  
5  
6  
7  
A

SDT  
SDM





SZCZĘKI JEDNOLITE TWARDE ODWRACALNE  
 КУЛАЧКИ ЦЕЛЬНЫЕ КАЛЕННЫЕ ПЕРЕВОРАЧИВАЮЩИЕСЯ

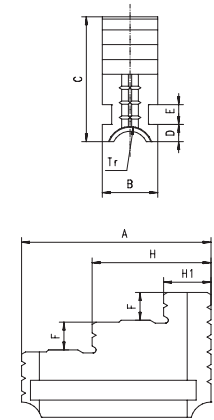

Uchwyt BISON	Wielkość uchwytu	Nr produktu	A	B	C	D	E	F	LH Gwint	H <sub>1</sub>	H	kg / szt.	
									LH Резьба				
Патрон BISON	Размер патрона	Код продукта											
Ø 200 - 800 mm	45*5; 47*5	200	398575150800	85	25	58	11,0	10	12	Tr 18 x 2	25,0	56,0	0,6
	46*5; 48*5	200	398575260000										
	45*5; 47*5	250	398575160000	91	28	61	10,0	10	14	Tr 18 x 2	26,5	60,0	0,8
	46*5; 48*5	250	398575270200										
	45*5; 47*5	315	398575170100	125	32	73	13,5	12	18	Tr 24 x 3	27,0	76,0	1,6
	46*5; 48*5	315	398575280400										
	45*5; 47*5	400	398575550100	145	36	90	12,0	14	22	Tr 24 x 3	35,0	98,2	1,8
	46*5; 48*5	400	398575710600										
	45*5; 47*5	500	398575560300	180	40	100	15,0	14	26	Tr 26 x 3	49,7	119,3	3,9
	46*5; 48*5	500	398575720800										
	45*5; 47*5	630	398575570500	225	50	108	14,0	14	28	Tr 26 x 3	65,0	148,0	4,5
	46*5; 48*5	630	398575730000										
45*5; 47*5	800	398575580700	230	52	109	13	15	28	Tr 36 x 6	60	145	6,0	
46*5; 48*5	800	398575740100											

- 1
- 2
- 3
- 4
- 5
- 6
- 7

Dystrybucja: unihurt.pl  
 Zamówienia: info@unihurt.pl  
 LRS



**SZCZĘKI JEDNOLITE MIĘKIE**  
КУЛАЧКИ МЯГКИЕ ЦЕЛЬНЫЕ

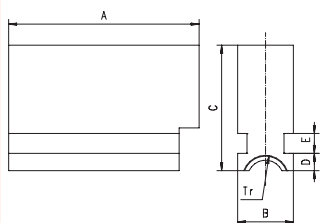

Uchwyt BISON	Wielkość uchwytu	Nr produktu	A	B	C	D	E	G	LH Gwint	H <sub>1</sub>	H	kg / szt.	
									LH Rzeźba			кг / шт.	
Патрон BISON	Размер патрона	Код продукта											
Ø 200 - 630 mm	45*5; 47*5	200	398575190500	85	25	58	11,0	10	12	Tr 18 x 2	25,0	56,0	0,6
	46*5; 48*5	200	398575300000										
	45*5; 47*5	250	398575200000	91	28	61	10,0	10	14	Tr 18 x 2	26,5	60,0	0,8
	46*5; 48*5	250	398575310200										
	45*5; 47*5	315	398575210100	125	32	73	13,5	12	18	Tr 24 x 3	27,0	76,0	1,6
	46*5; 48*5	315	398575320400										
	45*5; 47*5	400	398575610500	145	36	90	12,0	14	22	Tr 24 x 3	35,0	98,2	1,8
	46*5; 48*5	400	398575750300										
	45*5; 47*5	500	398575620700	180	40	100	15,0	14	26	Tr 26 x 3	49,7	119,3	3,9
	46*5; 48*5	500	398575760500										
	45*5; 47*5	630	398575630900	225	50	108	14,0	14	28	Tr 26 x 3	65,0	148,0	4,5
	46*5; 48*5	630	398575770700										



**SZCZĘKI PODSTAWOWE**  
КУЛАЧКИ МАСТЕР (РЕЙКИ)

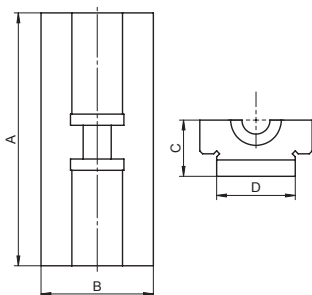

Uchwyt BISON	Wielkość uchwytu	Nr produktu	A	B	C	D	kg / szt.
							кг / шт.
Патрон BISON	Размер патрона	Код продукта					
Ø 200 - 800 mm	45*5; 47*5	200	398575230500				
	46*5; 48*5	200	398575340800	79	36	18	0,3
	45*5; 47*5	250	398575240700				
	46*5; 48*5	250	398575350000	90	40	20	0,4
	45*5; 47*5	315	398575250900				
	46*5; 48*5	315	398575360100	106	43	22	0,5
	45*5; 47*5	400	398575650200				
	46*5; 48*5	400	398575810700	129	49	23	0,7
	45*5; 47*5	500	398575660400				
	46*5; 48*5	500	398575820900	153	55	25	1,0
	45*5; 47*5	630	398575670600				
	46*5; 48*5	630	398575830000	186	64	26	1,6
	45*5; 47*5	800	398575680800				
	46*5; 48*5	800	398575840200	186	66	29	1,4



1

2

3

4

5

6

7

A

SJM

SP



SZCZĘKI JEDNOLITE TWARDE ODWRACALNE  
 КУЛАЧКИ ЦЕЛЬНЫЕ КАЛЕННЫЕ ПЕРЕВОРАЧИВАЮЩИЕСЯ

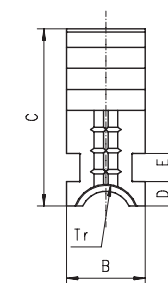
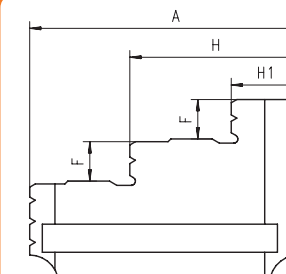

Uchwyt BISON	Wielkość uchwytu	Nr produktu	A	B	C	D	E	F	H <sub>1</sub>	H	LH Gwint	kg / szt.
											LH Резьба	кг / шт.
43**	85	398573100200	34,0	13	30,0	4,5	5	7	8,0	17,5	Tr 16x2	0,1
43**	100	398574010100	34,0	13	30,0	4,5	5	7	8,0	17,5	Tr 16x2	0,1
43**	125	398573110400	51,0	16	34,5	6,0	5	8	12,5	31,5	Tr 18x4	0,1
43**	160	398573110400	51,0	16	34,5	6,0	5	8	12,5	31,5	Tr 18x4	0,1
43**	200	398573120600	81,0	32	63,0	8,7	10	14	17,5	48,5	Tr 28x5	0,7
43**	250	398573130800	96,5	32	63,0	8,7	10	14	23,0	59,0	Tr 28x5	1,3
43**	315	398573140000	111,0	40	76,5	9,7	12	18	27,0	67,0	Tr 32x6	1,5
43**	350	398573140000	111,0	40	76,5	9,7	12	18	27,0	67,0	Tr 32x6	1,5
43**	400	398573150100	129,0	40	76,5	9,7	12	18	32,5	78,5	Tr 32x6	1,8
43**	500	398573160300	152,5	52	93,5	11,7	15	22	35,0	93,0	Tr 36x6	3,4
43**	630	398573170500	177,0	52	93,5	11,7	15	25	45,0	109,0	Tr 40x6	4,0
43**	800	398573180700	202,0	70	114,5	15,7	20	25	44,0	122,0	Tr 44x8	7,8

Ø 85 - 800 mm

- 1
- 2
- 3
- 4
- 5
- 6
- 7

Dystrybucja: [unihurt.pl](http://unihurt.pl)  
 Zamówienia: [info@unihurt.pl](mailto:info@unihurt.pl)  
 LRS

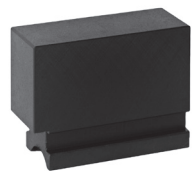

**SZCZĘKI JEDNOLITE MIĘKKIE**  
 КУЛАЧКИ МЯГКИЕ ЦЕЛЬНЫЕ

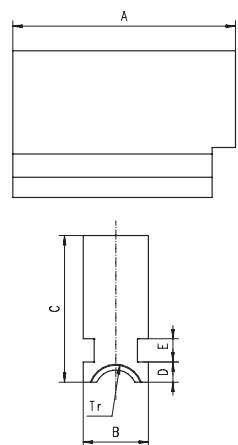

Uchwyt BISON	Wielkość uchwytu	Nr produktu	A	B	C	D	E	F	H <sub>1</sub>	H	LH Gwint	kg / szt.
											ЛH Резьба	кг / шт.
43**	200	398573020500	81,0	32	63,0	8,7	10	14	17,5	48,5	Tr 28x5	0,7
43**	250	398573030700	96,5	32	63,0	8,7	10	14	23,0	59,0	Tr 28x5	1,3
43**	315	398573040900	111,0	40	76,5	9,7	12	18	27,0	67,0	Tr 32x6	1,5
43**	400	398573050000	129,0	40	76,5	9,7	12	18	32,5	78,5	Tr 32x6	1,8
43**	500	398573060200	152,5	52	93,5	11,7	15	22	35,0	93,0	Tr 36x6	3,4
43**	630	398573070400	177,0	52	93,5	11,7	15	25	45,0	109,0	Tr 40x6	4,0
43**	800	398573080600	202,0	70	114,5	15,7	20	25	44,0	122,0	Tr 44x8	7,8

Ø 200 - 800 mm



1

2

3

4

5

6

7

A



**SZCZĘKI GÓRNE TWARDE**  
 КУЛАЧКИ КАЛЕННЫЕ НАКЛАДНЫЕ



Uchwyt BISON Патрон BISON	Wielkość uchwytu Размер патрона	Nr produktu Код продукта	A	B	C	D	E	F	G	H	J	K	L	M	N	O	P	R	kg / szt. кг / шт.	
			Ø 200 - 1250 mm	43**	200	398573620000	82	34	43,5	7,95	4	3,2	12,69	35,2	11	18	21,5	22,25	9,5	22,0
43**	250	398573630200	96,5	34	51,5	12,71	4	3,2	19,04	40,0	14	20	26,5	27,00	12,0	25,0	62,0	22,5	0,7	
43**	315	398573640400	112,5	42	55,0	12,71	4	3,2	19,04	47,9	14	20	27,5	31,75	13,0	27,0	70,5	25,7	1,3	
43**	400	398573650600	129	42	64,5	12,71	4	6,3	19,04	57,4	18	26	32,0	38,10	13,5	26,5	79,0	28,8	2,1	
43**	500; 630	398573670000	136	54	82,0	12,71	4	6,3	19,04	58,0	22	33	43,0	38,10	21,0	37,5	87,0	29,4	3,0	
43**	800	398573680100	136	72	88,0	12,71	4	6,3	19,04	58,0	22	33	46,0	38,10	24,0	40,0	89,0	29,4	4,2	
43**	915	398574490000	160	72	97,0	12,71	4	6,3	19,04	58,0	22	33	71,0	38,10	50,0	60,0	-	29,4	4,2	
43**	1000	398574490000	160	72	97,0	12,71	4	6,3	19,04	58,0	22	33	71,0	38,10	50,0	60,0	-	29,4	4,2	
43**	1250	398574490000	160	72	97,0	12,71	4	6,3	19,04	58,0	22	33	71,0	38,10	50,0	60,0	-	29,4	4,2	

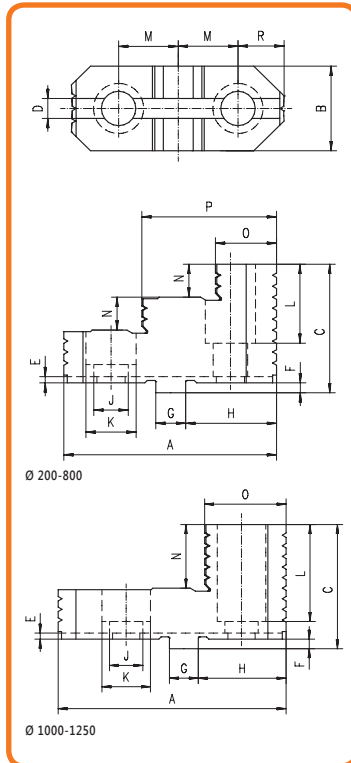

- 1
  - 2
  - 3
  - 4
  - 5
  - 6
  - 7
- Dystrybucja: [unihurt.pl](http://unihurt.pl)  
 Zamówienia: [info@unihurt.pl](mailto:info@unihurt.pl)



SZCZĘKI GÓRNE TWARDE • HD  
 КУЛАЧКИ КАЛЕННЫЕ НАКЛАДНЫЕ • HD

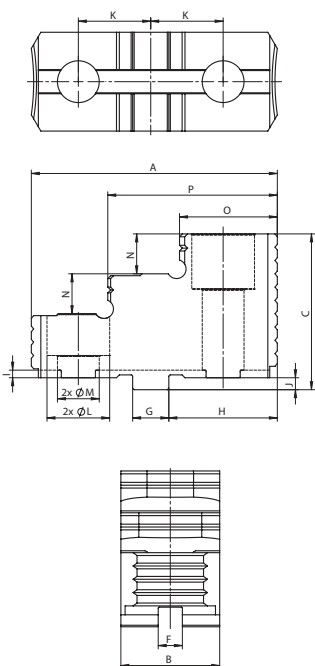

Uchwyt BISON	Nr produktu	A	B	C	F	G	H	I	J	K	M	L	N	O	P	kg / szt.	
																кг / шт.	
Патрон BISON	Код продукта																
4317-16"-8A2-5,3" HD																	
4317-16"-11A2 DIN-6,5" HD																	
4317-20"-11A2 DIN-6,5" HD																	
4317-20"-15A2 DIN-10" HD																	
4317-20"-15A2 DIN-8" HD	398573667700	135	62	82	12,71	19,04	57,1	4	6,3	38,1	22	33	21	55,9	88,7	2,74	
4347-16"-8-5,3" HD																	
4347-16"-11-6,5" HD																	
4347-20"-8-5,3" HD																	
4347-20"-11-6,5" HD																	
<b>Ø 400 - 1250 mm</b>																	
4317-25"-15A2 DIN-10,5" HD																	
4317-25"-20A2-10,5" HD																	
4317-25"-20A2-12,5" HD																	
4347-28"-11-7,5" HD																	
4317-28"-15A2 DIN-10,5" HD																	
4317-28"-20A2-12,5" HD																	
4317-32"-15A2 DIN-10,5" HD	398573677900	135	75	97	12,71	19,04	57,1	4	6,3	38,1	24	35	28	57,3	89,9	4,00	
4317-32"-20A2-12,5" HD																	
4317-32"-20A2-14,5" HD																	
4317-630-20A2-270 HD																	
4317-40"-28A2-20,5" HD																	
4307-1000-520-200 HD																	
4307-1250-520-200 HD																	
4317-49"-15A2 DIN-11" HD																	





**SZCZĘKI GÓRNE MIĘKKIE**  
 КУЛАЧКИ МЯГКИЕ НАКЛАДНЫЕ (СЫРЫЕ)



Uchwyt BISON	Wielkość uchwytu	Nr produktu	A	B	C	D	E	F	G	H	J	K	L1	M	kg / szt.
			Патрон BISON	Размер патрона	Код продукта										
43**	200	398538240200	90	27	43,5	7,95	4	3,2	12,69	40	11	18	31	22,25	0,7
43**	250	398538250400	106	32,5	51,5	12,71	4	3,2	19,04	45	14	20	38	27	1,2
43**	315	398538260600	120	37	55	12,71	4	3,2	19,04	53	14	20	40	31,75	1,6
43**	400	398538270800	140	42	64,5	12,71	4	6,3	19,04	63	18	26	45,5	38,1	2,2
43**	500	398538280000	140	42	74,5	12,71	4	6,3	19,04	63	22	33	56	38,1	2,4
43**	630	398574370500	140	54	82	12,71	4	6,3	19,04	58	22	33	64	38,1	3,6
43**	800	398574380700	140	72	88	12,71	4	6,3	19,04	58	22	33	70	38,1	5,5
43**	915	398574390900	160	72	97	12,71	4	6,3	19,04	58	22	33	72	38,1	7,2
43**	1000	398574390900	160	72	97	12,71	4	6,3	19,04	58	22	33	72	38,1	7,2
43**	1250	398574390900	160	72	97	12,71	4	6,3	19,04	58	22	33	72	38,1	7,2

Ø 200 - 1250 mm

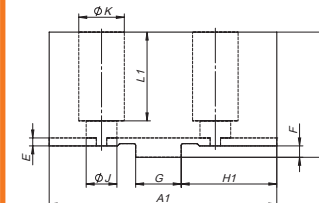
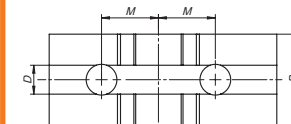

- 1
- 2
- 3
- 4
- 5
- 6

7

Dystrybucja: [unihurt.pl](http://unihurt.pl)  
 Zamówienia: [info@unihurt.pl](mailto:info@unihurt.pl)  
 SGM



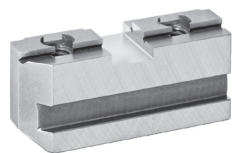

SZCZĘKI PODSTAWOWE  
 КУЛАЧКИ МАСТЕР (РЕЙКИ)

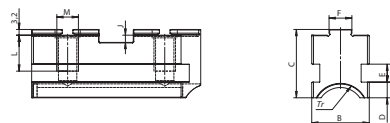

Ø 200-250

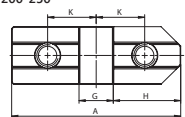

Ø 315-400

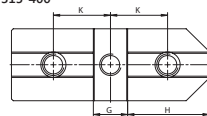

Ø 500

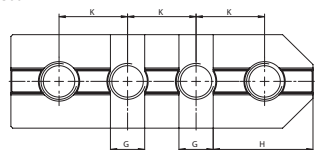

Ø 630-800

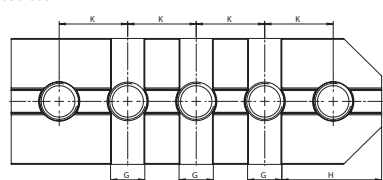

Ø 915-1250

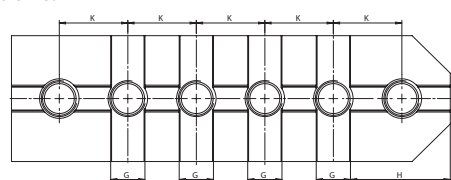

Uchwyt BISON	Wielkość uchwytu	Nr produktu	A	B	C	D	E	F	G	H	J	K	L	M	LH Gwint	kg / szt.
Патрон BISON	Размер патрона	Код продукта													LH Резьба	кг / шт.
43**	200	398573520000	79	32	32	8,7	10	7,94	12,69	33,2	4,0	22,25	14	M10	Tr 28x5	0,3
43**	250	398573530100	94	32	38	8,7	10	12,7	19,04	37,5	4,0	27,00	20	M12	Tr 28x5	0,6
43**	315	398573540300	110	40	39	9,7	12	12,7	19,04	45,4	4,0	31,75	17,5	M12	Tr 32x6	0,9
43**	400	398573550500	129	40	44	9,7	12	12,7	19,04	54,9	7,2	38,10	22	M16	Tr 32x6	0,9
43**	500	398573560700	168	52	59	11,7	15	12,7	19,04	55,5	7,2	38,10	35	M20	Tr 36x6	2,4
43**	630	398573570900	206	52	59	11,7	15	12,7	19,04	55,5	7,2	38,10	35	M20	Tr 40x6	2,7
43**	800	398573580000	206	70	59	15,7	20	12,7	19,04	55,5	7,2	38,10	33,5	M20	Tr 44x8	3,8
43**	915	398573590200	244	70	59	15,7	20	12,7	19,04	55,5	7,2	38,10	35	M20	Tr 44x6	5,4
43**	1000	398573590200	244	70	59	15,7	20	12,7	19,04	55,5	7,2	38,10	35	M20	Tr 44x6	5,4
43**	1250	398573590200	244	70	59	15,7	20	12,7	19,04	55,5	7,2	38,10	35	M20	Tr 44x6	5,4

Ø 200 - 1250 mm



1  
2  
3  
4  
5  
6  
7  
A



SZCZĘKI PODSTAWOWE - HD  
 КУЛАЧКИ МАСТЕР (РЕЙКИ) + HD

Uchwyt BISON	Nr produktu	A	B	C	D	E	F	G	H	J	K	L	M	LH Gwint	kg / szt.
														LH Резьба	кг / шт.
Патрон BISON	Код продукта														
4317-16"-8A2-5,3" HD 4347-16"-8-5,3" HD 4347-16"-11-6,5" HD 4317-16"-11A2 DIN-6,5" HD 4317-20"-15A2 DIN-10" HD	398572041300	132	60	58	15,7	20	12,7	19,04	57,1	7,2	38,1	33,5	3/4"	Tr 44x8	2,5
4347-20"-8-5,3" HD 4347-20"-11-6,5" HD 4317-20"-11A2 DIN-6,5" HD 4317-20"-15A2 DIN-8" HD	398572046700	170	60	58	15,7	20	12,7	19,04	57,1	7,2	38,1	33,5	3/4"	Tr 44x8	3,2
4317-25"-15A2 DIN-10,5" HD 4317-25"-20A2-10,5" HD 4317-25"-20A2-12,5" HD 4317-28"-20A2-12,5" HD 4347-28"-11-7,5" HD 4317-28"-15A2 DIN-10,5" HD 4317-32"-15A2 DIN-10,5" HD 4317-32"-20A2-12,5" HD 4317-32"-20A2-14,5" HD 4317-40"-28A2-20,5" HD	398573772600	208	70	61	15,7	20	12,7	19,04	57,1	7,2	38,1	33,5	7/8"	Tr 50x8	4,65

Ø 400 - 1250 mm

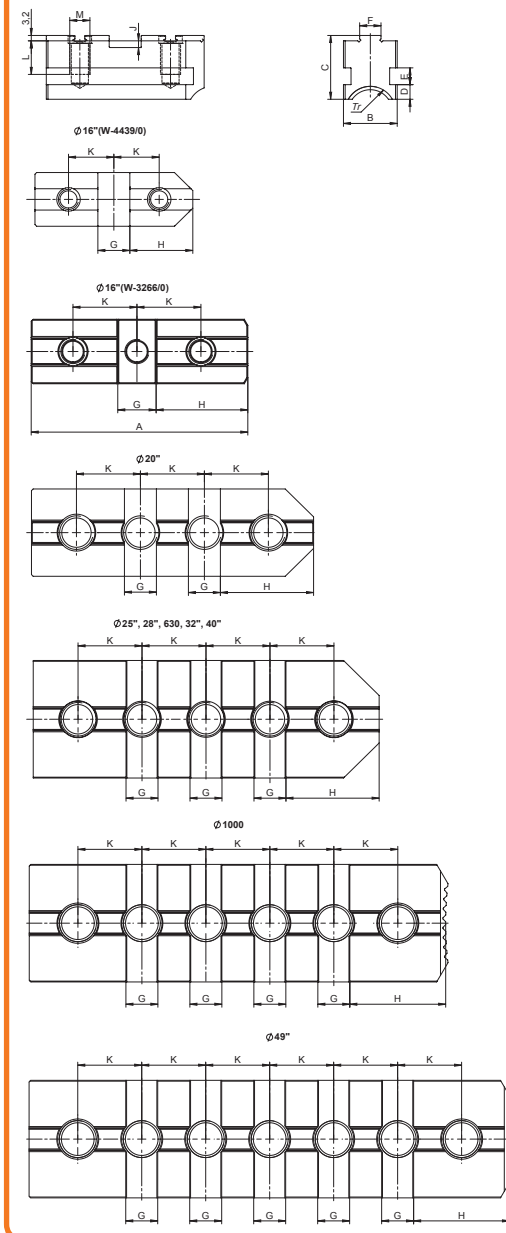

- 1
- 2
- 3
- 4
- 5
- 6
- 7

Dystrybucja: unihurt.pl  
 Zamówienia: info@unihurt.pl

PS

1  
2  
3  
4  
5  
6  
7  
A



**SZCZĘKI DZIELONE TWARDE ODWRACALNE**

КУЛАЧКИ СБОРНЫЕ КАЛЕННЫЕ ПЕРЕВОРАЧИВАЮЩИЕСЯ

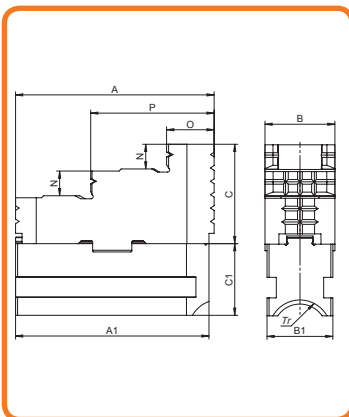

Uchwyt BISON	Wielkość uchwytu	Nr produktu	A	A1	B	B1	C	C1	N	O	P	LH Gwint	kg / szt.
												LH Резьба	
43**	200	398573820200	82	79	34	32	40,3	28,8	9,5	22,0	53,0	Tr 28x5	0,9
43**	250	398573830400	96,5	94	34	32	48,3	34,8	12,0	25,0	62,0	Tr 28x5	1,2
43**	315	398573840600	112,5	110	42	40	51,8	35,8	13,0	27,0	70,5	Tr 32x6	2,0
43**	400	398573850800	129	129	42	40	58,2	40,8	14,0	26,5	79,0	Tr 32x6	2,9
43**	500	398573960000	136	168	54	52	75,7	55,8	21,0	37,5	87,0	Tr 36x6	5,6
43**	630	398573870100	136	206	54	52	75,7	55,8	21,0	37,5	87,0	Tr 40x6	5,7
43**	800	398573880300	136	206	72	70	81,7	55,8	24,0	56,0	88,0	Tr 44x8	8,7
43**	915	398574290800	160	244	72	70	90,7	55,8	50,0	60,0	-	Tr 44x6	10,1
43**	1000	398574290800	160	244	72	70	90,7	55,8	50,0	60,0	-	Tr 44x6	10,1
43**	1250	398574290800	160	244	72	70	90,7	55,8	50,0	60,0	-	Tr 44x6	10,1

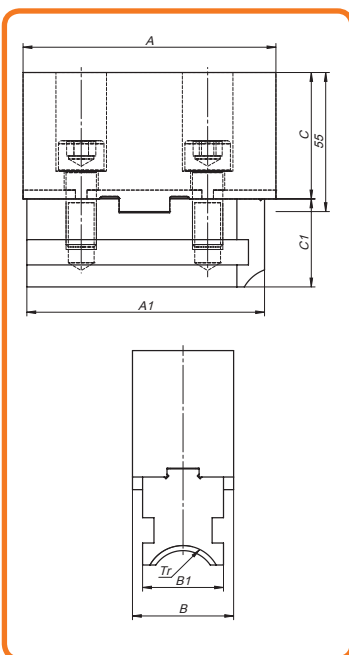

**SZCZĘKI DZIELONE MIĘKIE**

КУЛАЧКИ СБОРНЫЕ МЯГКИЕ



Uchwyt BISON	Wielkość uchwytu	Nr produktu	A	A1	B	B1	C	C1	LH Gwint	kg / szt.
43**	200	398574122100	90	79	27	32	40,3	28,8	Tr 28x5	1,0
43**	250	398574132100	106	94	32,5	32	48,3	34,8	Tr 28x5	1,9
43**	315	398574142300	120	110	37	40	51,8	35,8	Tr 32x6	2,6
43**	400	398574152500	140	129	42	40	58,2	40,8	Tr 32x6	3,3
43**	500	398574172900	140	168	42	52	68,2	55,8	Tr 36x6	5,1
43**	630	398574162700	140	206	54	52	75,7	55,8	Tr 40x6	6,6
43**	800	398574182000	140	206	72	70	81,7	55,8	Tr 44x8	9,7
43**	915	398574196300	160	244	72	70	90,7	55,8	Tr 44x6	12,9
43**	1000	398574196300	160	244	72	70	90,7	55,8	Tr 44x6	12,9
43**	1250	398574196300	160	244	72	70	90,7	55,8	Tr 44x6	12,9

SDT  
SDM

Dystrybucja: unihurt.pl  
Zamówienia: info@unihurt.pl



**SZCZĘKI DZIELONE TWARDE ODWRACALNE - HD**  
 КУЛАЧКИ СБОРНЫЕ КАЛЕННЫЕ ПЕРЕВОРАЧИВАЮЩИЕСЯ - HD

Uchwyt BISON	Nr produktu	A	A1	B	B1	C	C1	N	O	P	LH Gwint	kg / szt.
											LH Резьба	кг / шт.
4347-16"-8-5,3" HD 4317-16"-8A2-5,3" HD 4317-16"-11A2 DIN-6,5" HD 4347-16"-11-6,5" HD	398573865300	135	132	62	60	75,7	54,8	21	55,9	88,7	Tr 44x8	5,61
4347-20"-8-5,3" HD 4347-20"-11-6,5" HD 4317-20"-11A2 DIN-6,5" HD 4317-20"-15A2 DIN-10" HD 4317-20"-15A2 DIN-8" HD	398573866600	135	170	62	60	75,7	54,8	21	55,9	88,7	Tr 44x8	6,30
4317-25"-15A2 DIN-10,5" HD 4317-25"-20A2-10,5" HD 4317-25"-20A2-12,5" HD 4347-28"-11-7,5" HD 4317-28"-15A2 DIN-10,5" HD 4317-28"-20A2-12,5" HD 4317-32"-15A2 DIN-10,5" HD 4317-32"-20A2-12,5" HD 4317-32"-20A2-14,5" HD 4317-40"-28A2-20,5" HD	398573855100	135	208	75	70	90,7	57,8	28	57,3	89,9	Tr 50x8	9,17

Ø 400 - 1250 mm

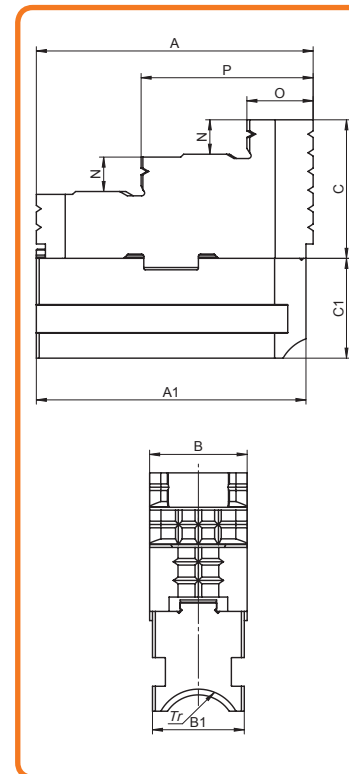

- 1
- 2
- 3
- 4
- 5
- 6

7

Dystrybucja: [unihurt.pl](http://unihurt.pl)



Zamówienia: [info@unihurt.pl](mailto:info@unihurt.pl) **IDS**



**SZCZĘKI GÓRNE TWARDE • DO UCHWYTU 2405-K**  
КУЛАЧКИ КАЛЕННЫЕ НАКЛАДНЫЕ • ДЛЯ ПАТРОНОВ 2405-K

**METRYCZNA WIELKOŚĆ KĄTA ZĄBKÓW 1,5 mm x 60° LUB 3,0 mm x 60°**  
МЕТРИЧЕСКОЕ ЗУБЧАТОЕ СОЕДИНЕНИЕ 1,5 мм x 60° ИЛИ 3,0 мм x 60°



Wkładki teowe str. 502  
Т-образные вкладки стр.

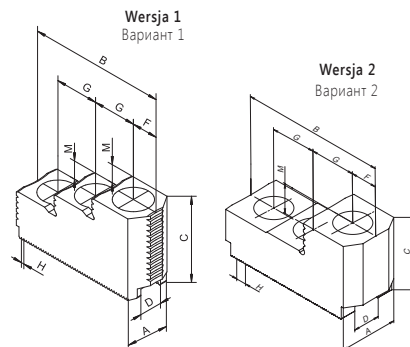

Uchwyt BISON	Nr produktu	Wielkość uchwytu	Wersja	A	B	C	D H7	F	G	H	M	LH Gwint	kg / szt.
												LH Резьба	
2405-135-34K	398521600400	135	1	23	53	36	10,0	13,0	14	1,5 mm x 60°	10	M8	1,4
2405-160-45K	398521611900	160	1	32	64	43	12,0	12,5	20	1,5 mm x 60°	10	M10	1,0
2405-200-52K	398521711000	200	1	35	79	49	14,0	14,5	25	1,5 mm x 60°	12	M12	1,6
2405-250-75K	398521721100	250	1	40	102	54	16,0	21,0	30	1,5 mm x 60°	14	M12	3,0
2405-315-91K	398521731300	315	1	45	102	58	21,0	21,0	30	1,5 mm x 60°	14	M16	3,1
2405-400-120K	398521741500	400	1	50	140	75	25,5	27	43	1,5 mm x 60°	18	M20	6,0
2405-500-160K	398521751700	500	1	50	140	75	25	27	43	3,0 mm x 60°	18	M20	6,2
2405-630-200K	398521762100	630	1	55	136	70	25	25	43	3,0 mm x 60°	28	M20	6,3
2405-800-255K	398521772300	800	2	55	136	70	25	25	43	3,0 mm x 60°	28	M20	6,3



**SZCZĘKI GÓRNE TWARDE • DO UCHWYTU 2405**  
КУЛАЧКИ КАЛЕННЫЕ НАКЛАДНЫЕ • ДЛЯ ПАТРОНОВ 2405

**CALOWA WIELKOŚĆ KĄTA ZĄBKÓW 1/16" x 90° LUB 3/32" x 90°**  
ДУЙМОВОЕ ЗУБЧАТОЕ СОЕДИНЕНИЕ 1/16" x 90° ИЛИ 3/32" x 90°



Wkładki teowe str. 502  
Т-образные вкладки стр.

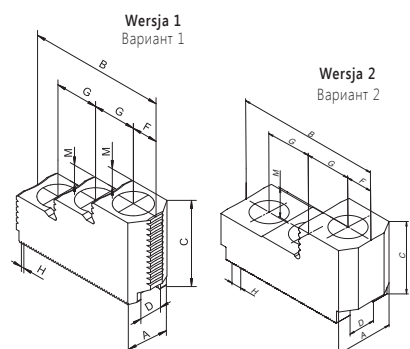

Uchwyt BISON	Nr produktu	Wielkość uchwytu	Wersja	A	B	C	D H7	F	G	H	M	LH Gwint	kg / szt.
												LH Резьба	
2405-160-45	398521610600	160	1	28	76	45	17	14	24	1/16" x 90°	10	M12	1,0
2405-200-52	398521710700	200	1	32	78	49	17	14,5	24,5	1/16" x 90°	12	M12	1,4
2405-250-75	398521720900	250	1	40	102	58	21	19	32	1/16" x 90°	14	M16	2,7
2405-315-91	398521730000	315	1	40	102	58	21	19	32	1/16" x 90°	14	M16	2,7
2405-400-120	398521742800	400	1	50	140	75	25,5	27	43	3/32" x 90°	18	M20	6,2
2405-500-160	398521742800	500	1	50	140	75	25,5	27	43	3/32" x 90°	18	M20	6,2
2405-630-200	398521761900	630	1	55	136	70	25,5	25	43	3/32" x 90°	28	M20	6,3
2405-800-255	398521771000	800	2	55	136	70	25,5	25	43	3/32" x 90°	28	M20	6,3





Wkładki teowe str. 502  
Т-образные вкладки стр.



SZCZĘKI GÓRNE TWARDE • DO UCHWYTU 2605-K  
КУЛАЧКИ КАЛЕННЫЕ НАКЛАДНЫЕ • ДЛЯ ПАТРОНОВ 2605-K

METRYCZNA WIELKOŚĆ KĄTA ZĄBKÓW 1,5 mm x 60°  
МЕТРИЧЕСКОЕ ЗУБЧАТОЕ СОЕДИНЕНИЕ 1,5 мм x 60°

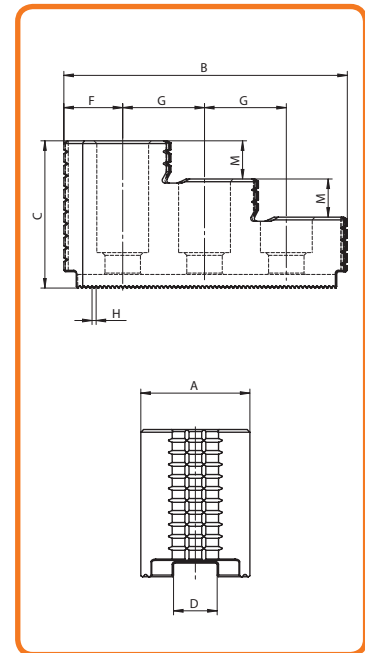

Ø 135 - 315 mm	Uchwyt BISON	Nr produktu	Wielkość uchwytu	A	B	C	D H7	F	G	H	M	LH Gwint	kg / szt.
	Патрон BISON	Код продукта	Размер патрона									LH Резьба	кг / шт.
	2605-135-34K	398521811000	135	23	53	36	10	13	14	1,5 mm x 60°	10	M8	0,5
	2605-160-45K	398521821200	160	32	64	43	12	12,5	20	1,5 mm x 60°	10	M10	1,3
	2605-200-52K	398521831400	200	35	79	49	14	14,5	25	1,5 mm x 60°	12	M12	2,1
	2605-250-75K	398521841600	250	40	102	54	16	21	30	1,5 mm x 60°	14	M12	2,9
	2605-315-91K	398521851800	315	45	102	58	21	21	30	1,5 mm x 60°	14	M16	4,0



Wkładki teowe str. 502  
Т-образные вкладки стр.



SZCZĘKI GÓRNE TWARDE • DO UCHWYTU 2605  
КУЛАЧКИ КАЛЕННЫЕ НАКЛАДНЫЕ • ДЛЯ ПАТРОНОВ 2605

SALOWA WIELKOŚĆ KĄTA ZĄBKÓW 1/16" x 90°  
ДЮЙМОВОЕ ЗУБЧАТОЕ СОЕДИНЕНИЕ 1/16" x 90°

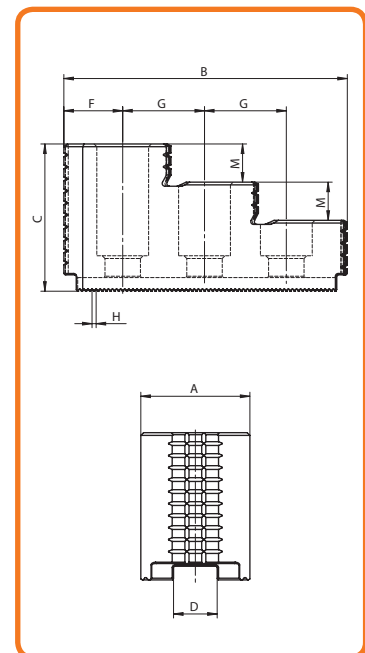

Ø 160 - 315 mm	Uchwyt BISON	Nr produktu	Wielkość uchwytu	A	B	C	D H7	F	G	H	M	LH Gwint	kg / szt.
	Патрон BISON	Код продукта	Размер патрона									LH Резьба	кг / шт.
	2605-160-45	398521810800	160	28	76	45	17	14	24	1/16" x 90°	10	M12	1,3
	2605-200-52	398521820000	200	32	78	49	17	14,5	24,5	1/16" x 90°	12	M12	1,8
	2605-250-75	398521830100	250	40	102	58	21	19	32	1/16" x 90°	14	M16	3,5
	2605-315-91	398521840300	315	40	102	58	21	19	32	1/16" x 90°	14	M16	3,5





1

2

3

4

5

6

7

B



**SZCZĘKI GÓRNE TWARDE - DO UCHWYTU 2409**  
КУЛАЧКИ КАЛЕННЫЕ НАКЛАДНЫЕ - ДЛЯ ПАТРОНОВ 2409

**CALOWA WIELKOŚĆ KĄTA ZĄBKÓW 1/16" x 90°**  
ДЮЙМОВОЕ ЗУБЧАТОЕ СОЕДИНЕНИЕ 1/16" x 90°



Wkładki teowe str. 502  
Т-образные вкладки кг / шт.

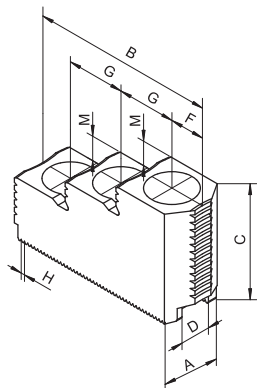

Ø 135 - 315 mm	Uchwyt BISON	Nr produktu	Wielkość uchwytu	A	B	C	D H7	F	G	H	M	LH Gwint	kg / szt.
	Патрон BISON	Код продукта	Размер патрона									LH Резьба	кг / шт.
	2409-160-46	398521780000	160	26	60	39	12	12,5	18,0	1/16" x 90°	10	M10	0,6
	2409-200-66	398521781200	200	28	76	45	17	14,0	24,0	1/16" x 90°	10	M12	1,0
	2409-250-91	398521782500	250	32	78	49	17	14,5	24,5	1/16" x 90°	12	M12	1,4
	2409-315-91	398521783800	315	32	78	49	17	14,5	24,5	1/16" x 90°	12	M12	1,4

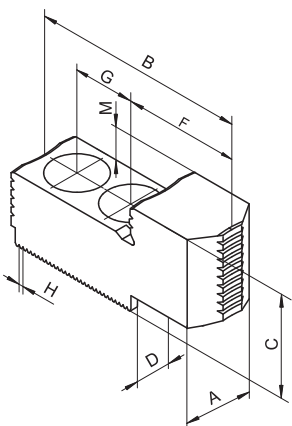

**SZCZĘKI GÓRNE TWARDE - DO UCHWYTU 2409**  
КУЛАЧКИ КАЛЕННЫЕ НАКЛАДНЫЕ - ДЛЯ ПАТРОНОВ 2409

**CALOWA WIELKOŚĆ KĄTA ZĄBKÓW 1/16" x 90°**  
ДЮЙМОВОЕ ЗУБЧАТОЕ СОЕДИНЕНИЕ 1/16" x 90°



Wkładki teowe str. 502  
Т-образные вкладки кг / шт.

Ø 160 - 315 mm	Uchwyt BISON	Nr produktu	Wielkość uchwytu	A	B	C	D H7	F	G	H	M	LH Gwint	kg / szt.
	Патрон BISON	Код продукта	Размер патрона									LH Резьба	кг / шт.
	2409-160-46	398521920000	160	26	67	29	12	38	18,0	1/16" x 90°	10	M10	0,6
	2409-200-66	398521930200	200	28	85	35	17	47	24,0	1/16" x 90°	10	M12	1,0
	2409-250-91	398521940400	250	32	95	38	17	55	24,5	1/16" x 90°	12	M12	1,5
	2409-315-91	398521940400	315	32	95	38	17	55	24,5	1/16" x 90°	12	M12	1,5





Wkładki teowe str. 502  
 Т-образные вкладки стр.



SZCZĘKI GÓRNE TWARDE • DO UCHWYTU 2488  
 КУЛАЧКИ КАЛЕННЫЕ НАКЛАДНЫЕ • ДЛЯ ПАТРОНОВ 2488

CALOWA WIELKOŚĆ KĄTA ZĄBKÓW 1/16" x 90°  
 ДЮЙМОВОЕ ЗУБЧАТОЕ СОЕДИНЕНИЕ 1/16" x 90°



Uchwyt BISON	Nr produktu	Wielkość uchwytu	A	B	C	D H7	F	G	H	M	LH Gwint	kg / szt.
											LH Резьба	кг / шт.
2488-160	398521610600	160	28	76	45	17	14	24	1/16" x 90°	10	M12	1,0
2488-200	398521710700	200	32	78	49	17	14,5	24,5	1/16" x 90°	12	M12	1,4
2488-250	398521720900	250	40	102	58	21	19	32	1/16" x 90°	14	M16	2,7
2488-315	398521730000	315	40	102	58	21	19	32	1/16" x 90°	14	M16	2,7

Ø 160 - 315 mm

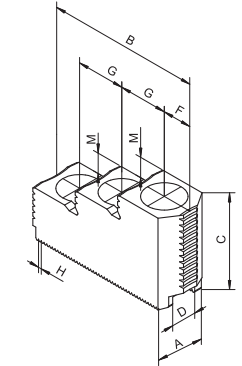

- 1
- 2
- 3
- 4
- 5
- 6
- 7

Dystrybucja: unihurt.pl  
 Zamówienia: info@unihurt.pl ; LGS



- 1
- 2
- 3
- 4
- 5
- 6
- 7
- B



**SZCZĘKI GÓRNE MIĘKKE - DO UCHWYTU 2105-K**  
КУЛАЧКИ МЯГКИЕ НАКЛАДНЫЕ (СЫРЫЕ) • ДЛЯ ПАТРОНОВ 2105-K

**METRYCZNA WIELKOŚĆ KĄTA ZĄBKÓW 1,5 mm x 60°**  
МЕТРИЧЕСКОЕ ЗУБЧАТОЕ СОЕДИНЕНИЕ 1,5 мм x 60°



Wkładki teowe str. 502  
T-образные вкладки стр.

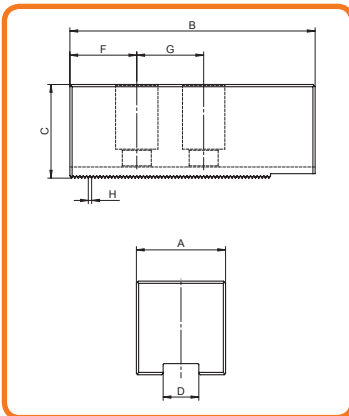

Ø 135 - 315 mm	Uchwyt BISON	Nr produktu	Wielkość uchwytu	A	B	C	D H7	F	G	H	LH Gwint	kg / szt.
	Патрон BISON	Код продукта	Размер патрона								LH Резьба	кг / шт.
	2105-135-34K	398521210200	135	25	54	25	10	12	14	1,5 mm x 60°	M8	0,4
	2105-160-45K	398521220400	160	40	65	40	12	12	20	1,5 mm x 60°	M10	1,3
	2105-200-52K	398521240800	200	40	95	40	14	24	25	1,5 mm x 60°	M12	2,0
	2105-250-75K	398521250000	250	50	105	50	16	30	30	1,5 mm x 60°	M12	3,5
	2105-315-91K	398521260100	315	50	110	50	21	21	30	1,5 mm x 60°	M16	3,4



**SZCZĘKI GÓRNE MIĘKKE - DO UCHWYTU 2105**  
КУЛАЧКИ МЯГКИЕ НАКЛАДНЫЕ (СЫРЫЕ) • ДЛЯ ПАТРОНОВ 2105

**CALOWA WIELKOŚĆ KĄTA ZĄBKÓW 1/16" x 90°**  
ДЮЙМОВОЕ ЗУБЧАТОЕ СОЕДИНЕНИЕ 1/16" x 90°



Wkładki teowe str. 502  
T-образные вкладки стр.

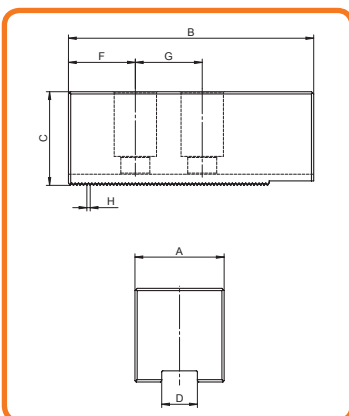

Ø 160 - 315 mm	Uchwyt BISON	Nr produktu	Wielkość uchwytu	A	B	C	D H7	F	G	H	LH Gwint	kg / szt.
	Патрон BISON	Код продукта	Размер патрона								LH Резьба	кг / шт.
	2105-160-45	398520010200	160	40	65	40	17	15	24	1/16" x 90°	M12	1,2
	2105-200-52	398520020400	200	40	95	40	17	15	24	1/16" x 90°	M12	1,9
	2105-250-75	398520030600	250	45	105	50	21	20	28	1/16" x 90°	M16	3,2
	2105-315-91	398520040800	315	45	110	50	21	20	28	1/16" x 90°	M16	3,4

SGM 2105-K  
SGM 2105

Dystrybucja: unihurt.pl  
Zamówienia: info@unihurt.pl



Wkładki teowe str. 502  
 Т-образные вкладки стр.



SZCZĘKI GÓRNE MIĘKKIE • DO UCHWYTU 2405-K  
 КУЛАЧКИ МЯГКИЕ НАКЛАДНЫЕ (СЫРЫЕ) • ДЛЯ ПАТРОНОВ 2405-K

METRYCZNA WIELKOŚĆ KĄTA ZĄBKÓW 1,5 mm x 60° LUB 3,0 mm x 60°  
 МЕТРИЧЕСКОЕ ЗУБЧАТОЕ СОЕДИНЕНИЕ 1,5 мм x 60° ИЛИ 3,0 мм x 60°



Ø 135 - 800 mm

Uchwyt BISON	Nr produktu	Wielkość uchwytu	Wersja	A	B	C	D H7	F	G	G1	H	LH Gwint	kg / szt.
Патрон BISON	Код продукта	Размер патрона	Вариант									LH Резьба	кг / шт.
2405-135-34K	398521500300	135	1	25	54	25	10	12	14	-	1,5 mm x 60°	M8	0,6
2405-160-45K	398521511800	160	1	40	65	40	12	12	20	-	1,5 mm x 60°	M10	1,8
2405-200-52K	398521521000	200	1	40	95	40	14	24	25	-	1,5 mm x 60°	M12	2,8
2405-250-75K	398521531100	250	1	50	105	50	16	30	30	-	1,5 mm x 60°	M12	5,1
2405-315-91K	398521541300	315	1	50	110	50	21	21	30	-	1,5 mm x 60°	M16	5,0
2405-400-120K	398521552800	400	2	60	140	60	25,5	26	43	-	1,5 mm x 60°	M20	9,5
2405-500-160K	398521553000	500	2	60	140	60	25	26	43	-	3,0 mm x 60°	M20	9,5
2405-630-200K	398521554300	630	3	70	170	70	25	27	43	43	3,0 mm x 60°	M20	15,2
2405-800-255K	398521554300	800	3	70	170	70	25	27	43	43	3,0 mm x 60°	M20	15,2

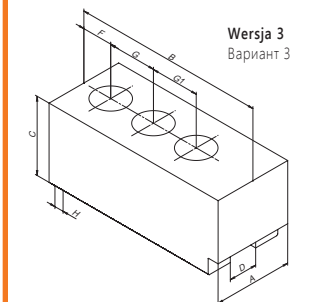
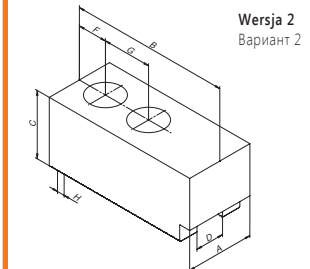
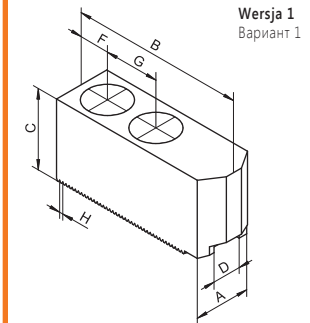

- 1
- 2
- 3
- 4
- 5
- 6
- 7

Dystrybucja: unihurt.pl  
 Zamówienia: info@unihurt.pl  
 SGM 2





**SZCZĘKI GÓRNE MIĘKIE - DO UCHWYTU 2405**  
КУЛАЧКИ МЯГКИЕ НАКЛАДНЫЕ (СЫРЫЕ) • ДЛЯ ПАТРОНОВ 2405



**WIELKOŚĆ KĄTA ZĄBKÓW 1/16" x 90° LUB 3/32" x 90°**  
ДЮЙМОВОЕ ЗУБЧАТОЕ СОЕДИНЕНИЕ 1/16" x 90° ИЛИ 3/32" x 90°



Wkładki teowe str. 502  
T-образные вкладки стр.

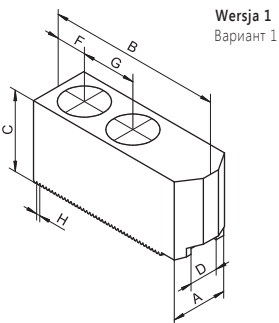

Wersja 1  
Вариант 1

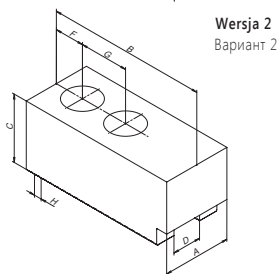

Wersja 2  
Вариант 2

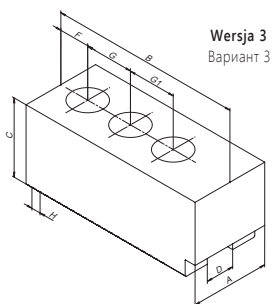

Wersja 3  
Вариант 3

Uchwyt BISON Патрон BISON	Nr produktu Код продукта	Wielkość uchwytu Размер патрона	Wersja Вариант	A	B	C	D H7	F	G	G1	H	LH Gwint	kg / szt.
												LH Резьба	
2405-160-45	398521510500	160	1	40	65	40	17	15	24	-	1/16" x 90°	M12	1,7
2405-200-52	398521520700	200	1	40	95	40	17	15	24	-	1/16" x 90°	M12	2,8
2405-250-75	398521530900	250	1	50	105	50	21	20	28	-	1/16" x 90°	M16	4,7
2405-315-91	398521540000	315	1	50	110	50	21	20	28	-	1/16" x 90°	M16	5,0
2405-400-120	398521550200	400	2	60	140	60	25,5	25	35	-	3/32" x 90°	M20	6,5
2405-500-160	398521550200	500	2	60	140	60	25,5	25	35	-	3/32" x 90°	M20	9,5
2405-630-200	398521555600	630	3	70	170	70	25,5	27	43	43	3/32" x 90°	M20	15,2
2405-800-255	398521555600	800	3	70	170	70	25,5	27	43	43	3/32" x 90°	M20	15,2

Ø 160 - 800 mm



1

2

3

4

5

6

7

B





Wkładki teowe str. 502  
 T-образные вкладки стр.



**SZCZĘKI GÓRNE MIĘKKIE • DO UCHWYTU 2605-K**  
 КУЛАЧКИ МЯГКИЕ НАКЛАДНЫЕ (СЫРЫЕ) • ДЛЯ ПАТРОНОВ 2605-K

**METRYCZNA WIELKOŚĆ KĄTA ZĄBKÓW 1,5 mm x 60° LUB 3,0 mm x 60°**  
 МЕТРИЧЕСКОЕ ЗУБЧАТОЕ СОЕДИНЕНИЕ 1,5 мм x 60° ИЛИ 3,0 мм x 60°



Ø 135 - 800 mm

Uchwyt BISON	Nr produktu	Wielkość uchwytu	Wersja	A	B	C	D H7	F	G	G1	H	LH Gwint	kg / szt.		
Патрон BISON	Код продукта	Размер патрона	Вариант											LH Резьба	кг / шт.
2605-135-34K	398521843100	135	1	25	54	25	10	12	14	-	1,5 mm x 60°	M8	0,8		
2605-160-45K	398521853300	160	1	40	65	40	12	12	20	-	1,5 mm x 60°	M10	2,3		
2605-200-52K	398521875200	200	1	40	95	40	14	24	25	-	1,5 mm x 60°	M12	3,7		
2605-250-75K	398521885400	250	1	50	105	50	16	30	30	-	1,5 mm x 60°	M12	6,6		
2605-315-91K	398521896800	315	1	50	110	50	21	21	30	-	1,5 mm x 60°	M16	6,6		
2405-400-120K	398521898400	400	2	60	140	60	25,5	26	43	-	1,5 mm x 60°	M20	9,5		
2405-500-160K	398521899700	500	2	60	140	60	25	26	43	-	3,0 mm x 60°	M20	9,5		
2405-630-200K	398521892800	630	3	70	170	70	25	27	43	43	3,0 mm x 60°	M20	15,2		
2405-800-255K	398521892800	800	3	70	170	70	25	27	43	43	3,0 mm x 60°	M20	15,2		

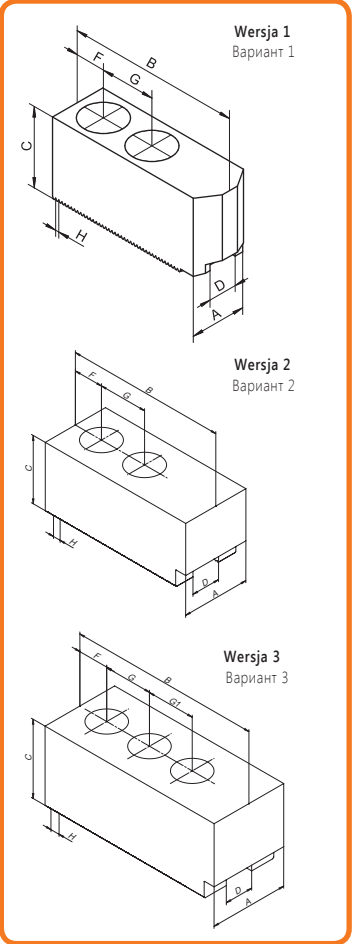

- 1
- 2
- 3
- 4
- 5
- 6

7

Dystrybucja: unihurt.pl  
  
 Zamówienia: info@unihurt.pl  
 SGM 2







**SZCZĘKI GÓRNE MIĘKKIE - DO UCHWYTU 2605**  
 КУЛАЧКИ МЯГКИЕ НАКЛАДНЫЕ (СЫРЫЕ) - ДЛЯ ПАТРОНОВ 2605

**CALOWA WIELKOŚĆ KĄTA ZĄBKÓW 1/16" x 90° LUB 3/32" x 90°**  
 ДЮЙМОВОЕ ЗУБЧАТОЕ СОЕДИНЕНИЕ 1/16" x 90° ИЛИ 3/32" x 90°



Wkładki teowe str. 502  
 T-образные вкладки стр.

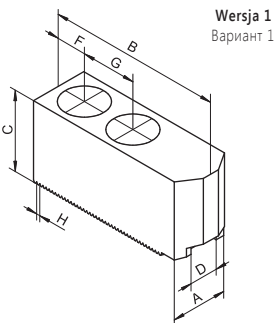

Wersja 1  
 Вариант 1

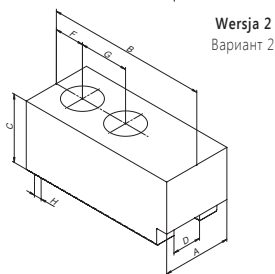

Wersja 2  
 Вариант 2

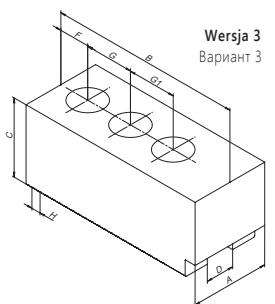

Wersja 3  
 Вариант 3

Uchwyt BISON Патрон BISON	Nr produktu Код продукта	Wielkość uchwytu Размер патрона	Wersja Вариант	A	B	C	D H7	F	G	G1	H	LH Gwint	kg / szt.
												LH Резьба	кг / шт.
2605-160-45	398521560700	160	1	40	65	40	17	15	24	-	1/16" x 90°	M12	2,1
2605-200-52	398521870900	200	1	40	95	40	17	15	24	-	1/16" x 90°	M12	3,6
2605-250-75	398521880000	250	1	50	105	50	21	20	28	-	1/16" x 90°	M16	6,0
2605-315-91	398521890200	315	1	50	110	50	21	20	28	-	1/16" x 90°	M16	6,6
2405-400-120	398521801900	400	2	60	140	60	25,5	25	35	-	3/32x90	M20	9,5
2405-500-160	398521801900	500	2	60	140	60	25,5	25	35	-	3/32x90	M20	9,5
2405-630-200	398521802100	630	3	70	170	70	25,5	27	43	43	3/32x90	M20	15,2
2405-800-255	398521802100	800	3	70	170	70	25,5	27	43	43	3/32x90	M20	15,2

Ø 160 - 800 mm



- 1
- 2
- 3
- 4
- 5
- 6
- 7

B

SGM 2605



Wkładki teowe str. 502  
 Т-образные вкладки стр.



**SZCZĘKI GÓRNE MIĘKIE - DO UCHWYTU 2409**  
 КУЛАЧКИ МЯГКИЕ НАКЛАДНЫЕ (СЫРЫЕ) • ДЛЯ ПАТРОНОВ 2409

**CALOWA WIELKOŚĆ KĄTA ZĄBKÓW 1/16" x 90°**  
 ДЮЙМОВОЕ ЗУБЧАТОЕ СОЕДИНЕНИЕ 1/16" x 90°



Ø 160 - 315 mm	Uchwyt BISON	Nr produktu	Wielkość uchwytu	A	B	C	D H7	F	G	H	LH Gwint	kg / szt.
	Патрон BISON	Код продукта	Размер патрона								LH Резьба	кг / шт.
	2409-160-46	398521570600	160	26	56	38	12	11	18	1/16" x 90°	M10	0,9
	2409-200-66	398521510500	200	40	65	40	17	15	24	1/16" x 90°	M12	1,7
	2409-250-91	398521520700	250	40	95	40	17	15	24	1/16" x 90°	M12	2,8
	2409-315-91	398521520700	315	50	95	40	17	15	24	1/16" x 90°	M12	2,8

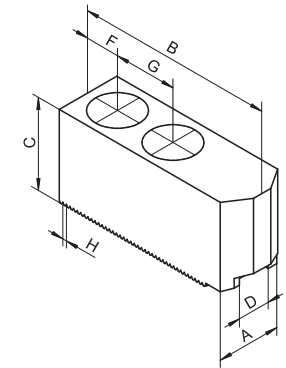

Wkładki teowe str. 502  
 Т-образные вкладки стр.



**SZCZĘKI GÓRNE MIĘKIE - DO UCHWYTU 2488**  
 КУЛАЧКИ МЯГКИЕ НАКЛАДНЫЕ (СЫРЫЕ) • ДЛЯ ПАТРОНОВ 2488

**CALOWA WIELKOŚĆ KĄTA ZĄBKÓW 1/16" x 90°**  
 ДЮЙМОВОЕ ЗУБЧАТОЕ СОЕДИНЕНИЕ 1/16" x 90°



Ø 160 - 315 mm	Uchwyt BISON	Nr produktu	Wielkość uchwytu	A	B	C	D H7	F	G	H	LH Gwint	kg / szt.
	Патрон BISON	Код продукта	Размер патрона								LH Резьба	кг / шт.
	2488-160	398521510500	160	40	65	40	17	15	24	1/16" x 90°	M12	1,7
	2488-200	398521520700	200	40	95	40	17	15	24	1/16" x 90°	M12	2,8
	2488-250	398521530900	250	50	105	50	21	20	28	1/16" x 90°	M16	4,7
	2488-315	398521540000	315	50	110	50	21	20	28	1/16" x 90°	M16	5,0

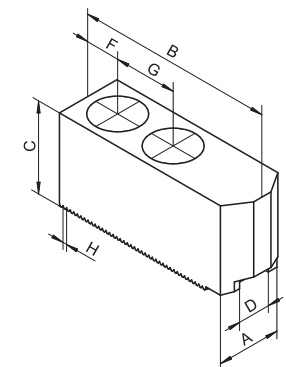

1  
2  
3  
4  
5  
6  
7  
B

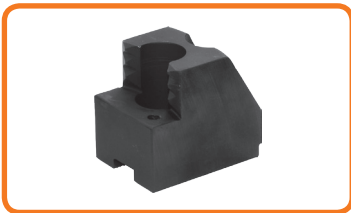

**SZCZĘKI CHWYTAKOWE - MOCOWANIE WEWNĘTRZNE**  
 КУЛАЧКИ ЗУБЧАТЫЕ - ВНУТРЕННИЙ ЗАЖИМ

**METRYCZNA WIELKOŚĆ KĄTA ZĄBKÓW 1,5 mm x 60°**  
 МЕТРИЧЕСКОЕ ЗУБЧАТОЕ СОЕДИНЕНИЕ 1,5 мм x 60°

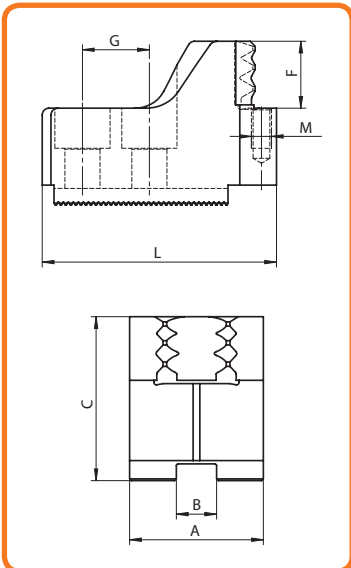

Uchwyt BISON	Nr produktu	Wielkość uchwytu	Zakres mocowania	A	B	C	F	G	L	M	kg / kpl.
Патрон BISON	Код продукта	Размер патрона	Диапазон зажима								кг / кпл.
2405-160-45K	398521609900	160	28 - 55	40	12	49	20	20	74,0	M6	1,9
2405-160-45K	398521612100	160	36 - 68	40	12	49	20	20	68,0	M6	1,7
2405-160-45K	398521613400	160	50 - 81	40	12	49	20	20	70,0	M6	1,8
2405-160-45K	398521614700	160	63 - 97	40	12	49	20	20	60,0	M6	1,5
2405-160-45K	398521615000	160	80 - 112	40	12	49	20	20	60,0	M6	1,7
2405-200-52K	398521716300	200	29 - 72	40	14	49	20	25	83,0	M6	2,0
2405-200-52K	398521714800	200	63 - 100	40	14	49	20	25	69,0	M6	1,8
2405-200-52K	398521713500	200	92 - 129	40	14	49	20	25	57,0	M6	1,5
2405-200-52K	398521717600	200	111 - 158	40	14	49	20	25	50,0	M6	1,2
2405-200-52K	398521715000	200	150 - 189	40	14	49	20	25	73,5	M6	2,0
2405-250-75K	398521722400	250	40 - 94	40	16	59	25	30	97,0	M6	2,9
2405-250-75K	398521723700	250	78 - 130	40	16	59	25	30	78,0	M6	2,2
2405-250-75K	398521724000	250	121 - 173	40	16	59	25	30	67,0	M6	2,0
2405-250-75K	398521725200	250	166 - 215	40	16	59	25	30	66,5	M6	2,0
2405-250-75K	398521726500	250	203 - 252	40	16	59	25	30	85,5	M6	2,6
2405-315-91K	398521732600	315	41 - 127	50	21	59	30	30	120,0	M8	4,0
2405-315-91K	398521733900	315	89 - 181	50	21	59	30	30	95,0	M8	3,2
2405-315-91K	398521734100	315	153 - 245	50	21	59	30	30	75,0	M8	2,4
2405-315-91K	398521735400	315	219 - 300	50	21	59	30	30	85,0	M8	3,1

**Kolki опорowe** str. 503  
 Опорные шпильки стр.

**Wkładki teowe** str. 502  
 Т-образные вкладки стр.

SW KB 2405-K

Dystrybucja: unihurt.pl  
 Zamówienia: info@unihurt.pl



SZCZĘKI CHWYTAKOWE - MOCOWANIE ZEWNĘTRZNE  
КУЛАЧКИ ЗУБЧАТЫЕ - ВНЕШНИЙ ЗАЖИМ

METRYCZNA WIELKOŚĆ KĄTA ZĄBKÓW 1,5 mm x 60°  
МЕТРИЧЕСКОЕ ЗУБЧАТОЕ СОЕДИНЕНИЕ 1,5 мм x 60°



Uchwyt BISON Патрон BISON	Nr produktu Код продукта	Wielkość uchwytu Размер патрона	Zakres mocowania Диапазон зажима	A	B	C	F	G	L	M	kg / kpl.
											кг / кпл.
2405-160-45K	398521616200	160	43 - 70	40	12	49	20	20	75	M6	1,7
2405-160-45K	398521617500	160	48 - 81	40	12	49	20	20	72	M6	1,6
2405-160-45K	398521618800	160	67 - 99	40	12	49	20	20	72	M6	1,7
2405-160-45K	398521619000	160	89 - 123	40	12	49	20	20	64	M6	1,8
2405-200-52K	398521718900	200	46 - 89	40	14	49	20	25	82	M6	1,8
2405-200-52K	398521712200	200	80 - 117	40	14	49	20	25	69	M6	1,7
2405-200-52K	398521719100	200	106 - 150	40	14	49	20	25	63	M6	1,7
2405-200-52K	398521700500	200	138 - 182	40	14	49	20	25	60	M6	1,8
2405-250-75K	398521727800	250	59 - 110	40	16	59	25	30	97	M6	2,5
2405-250-75K	398521728000	250	95 - 147	40	16	59	25	30	80	M6	2,4
2405-250-75K	398521729300	250	133 - 185	40	16	59	25	30	71	M6	2,2
2405-250-75K	398521701800	250	172 - 224	40	16	59	25	30	65	M6	2,6
2405-315-91K	398521736700	315	74 - 156	50	21	49	20	30	105	M8	3,0
2405-315-91K	398521737000	315	134 - 216	50	21	49	20	30	82	M8	2,5
2405-315-91K	398521738200	315	192 - 278	50	21	49	20	30	82	M8	2,6
2405-315-91K	398521739500	315	252 - 330	50	21	49	20	30	90	M8	3,3

1,5 mm x 60°

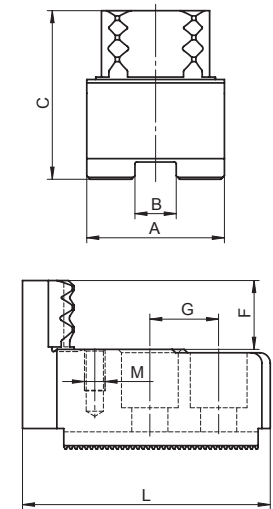

**Kotki oporowe** str. 503  
Опорные шпильки стр.

**Wkładki teowe** str. 502  
Т-образные вкладки стр.

- 1
- 2
- 3
- 4
- 5
- 6
- 7



**SZCZĘKI CHWYTAKOWE - MOCOWANIE WEWNĘTRZNE**  
 КУЛАЧКИ ЗУБЧАТЫЕ - ВНУТРЕННИЙ ЗАЖИМ

**CAŁOWA WIELKOŚĆ KĄTA ZĄBKÓW 1/16" x 90°**  
 ДЮЙМОВОЕ ЗУБЧАТОЕ СОЕДИНЕНИЕ 1/16" x 90°

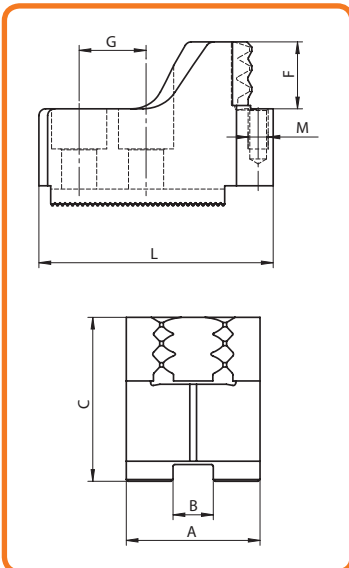

1/16" x 90°

Uchwyt BISON	Nr produktu	Wielkość uchwytu	Zakres mocowania	A	B	C	F	G	L	M	kg / kpl.
Патрон BISON	Код продукта	Размер патрона	Диапазон зажима								кг / кпл.
2405-160-45	398522520500	160	28 - 55	40	17	49	20	24	74,0	M6	1,8
2405-160-45	398522521800	160	36 - 68	40	17	49	20	24	68,0	M6	1,6
2405-160-45	398522522000	160	50 - 81	40	17	49	20	24	70,0	M6	1,6
2405-160-45	398522523300	160	63 - 97	40	17	49	20	24	60,0	M6	1,3
2405-160-45	398522524600	160	80 - 112	40	17	49	20	24	60,0	M6	1,5
2405-200-52	398522530700	200	29 - 72	40	17	49	20	23	83,0	M6	2,0
2405-200-52	398522531000	200	63 - 100	40	17	49	20	23	69,0	M6	1,8
2405-200-52	398522532200	200	92 - 129	40	17	49	20	23	57,0	M6	1,5
2405-200-52	398522533500	200	111 - 158	40	17	49	20	23	50,0	M6	1,2
2405-200-52	398522534800	200	150 - 189	40	17	49	20	23	73,5	M6	2,0
2405-250-75	398522540900	250	40 - 94	40	21	59	25	30	97,0	M6	2,6
2405-250-75	398522541100	250	78 - 130	40	21	59	25	30	78,0	M6	1,9
2405-250-75	398522542400	250	121 - 173	40	21	59	25	30	67,0	M6	1,7
2405-250-75	398522543700	250	166 - 215	40	21	59	25	30	66,5	M6	1,6
2405-250-75	398522544000	250	203 - 252	40	21	59	25	30	85,5	M6	2,4
2405-315-91	398522550000	315	41 - 127	50	21	59	30	30	120,0	M8	4,0
2405-315-91	398522551300	315	89 - 181	50	21	59	30	30	95,0	M8	3,2
2405-315-91	398522552600	315	153 - 245	50	21	59	30	30	75,0	M8	2,4
2405-315-91	398522553900	315	219 - 300	50	21	59	30	30	85,0	M8	3,1

**Kółki опорowe** str. 503  
 Опорные шпильки стр.

**Wkładki teowe** str. 502  
 Т-образные вкладки стр.

SW KB 2405

Dystrybucja: unihurt.pl  
 Zamówienia: info@unihurt.pl



**SZCZĘKI CHWYТАKOWE - MOCOWANIE ZEWNĘTRZNE**  
КУЛАЧКИ ЗУБЧАТЫЕ - ВНЕШНИЙ ЗАЖИМ

**CAŁOWA WIELKOŚĆ KĄTA ZĄBKÓW 1/16" x 90°**  
ДЮЙМОВОЕ ЗУБЧАТОЕ СОЕДИНЕНИЕ 1/16" x 90°



Uchwyt BISON	Nr produktu	Wielkość uchwytu	Zakres mocowania	A	B	C	F	G	L	M	kg / kpl.
											Патрон BISON
2405-160-45	398522525900	160	43 - 70	40	17	49	20	24	75	M6	1,5
2405-160-45	398522526100	160	48 - 81	40	17	49	20	24	72	M6	1,5
2405-160-45	398522527400	160	67 - 99	40	17	49	20	24	72	M6	1,7
2405-160-45	398522528700	160	89 - 123	40	17	49	20	24	64	M6	1,7
2405-200-52	398522535000	200	46 - 89	40	17	49	20	23	82	M6	1,7
2405-200-52	398522536300	200	80 - 117	40	17	49	20	23	69	M6	1,7
2405-200-52	398522537600	200	106 - 150	40	17	49	20	23	63	M6	1,6
2405-200-52	398522538900	200	138 - 182	40	17	49	20	23	60	M6	1,7
2405-250-75	398522545200	250	59 - 110	40	21	59	25	30	97	M6	2,3
2405-250-75	398522546500	250	95 - 147	40	21	59	25	30	80	M6	2,1
2405-250-75	398522547800	250	133 - 185	40	21	59	25	30	71	M6	1,9
2405-250-75	398522548000	250	172 - 224	40	21	59	25	30	65	M6	1,9
2405-315-91	398522554100	315	74 - 156	50	21	49	20	30	105	M8	3,0
2405-315-91	398522555400	315	134 - 216	50	21	49	20	30	82	M8	2,5
2405-315-91	398522556700	315	192 - 278	50	21	49	20	30	82	M8	2,6
2405-315-91	398522557000	315	252 - 330	50	21	49	20	30	90	M8	3,3

1/16" x 90°

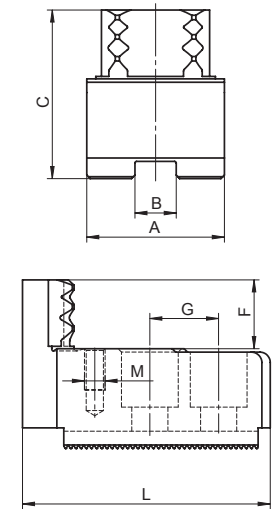

**Kółki oporowe** str. 503  
Опорные шпильки стр.

**Wkładki teowe** str. 502  
Т-образные вкладки стр.



**SZCZĘKI GÓRNE MIĘKIE**  
 КУЛАЧКИ МЯГКИЕ НАКЛАДНЫЕ (СЫРЫЕ)

**METRYCZNA WIELKOŚĆ KĄTA ZĄBKÓW 1,5 mm x 60°**  
 МЕТРИЧЕСКОЕ ЗУБЧАТОЕ СОЕДИНЕНИЕ 1,5 мм x 60°

- 1
- 2
- 3
- 4
- 5
- 6
- 7
- C

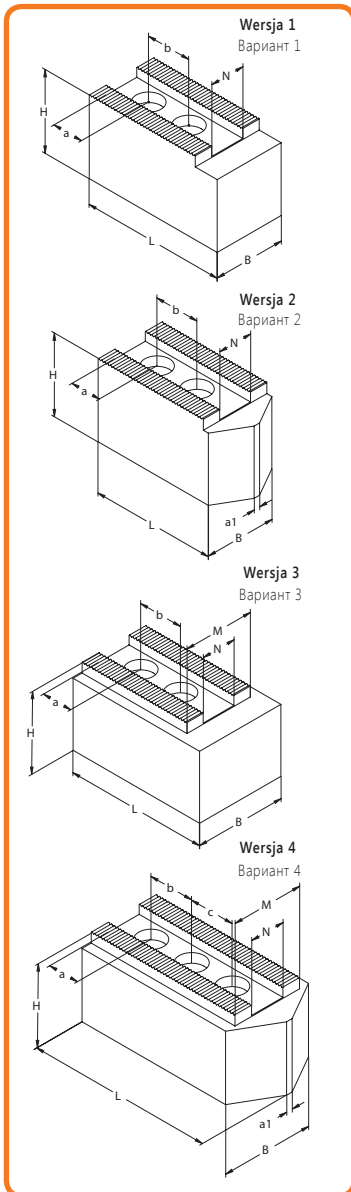

Nr produktu	Typ szczęk	Wersja	N	B	H	L	M	a <sub>1</sub>	a + b	Śruby		kg / kpl.
										Код продукта	Тип кулачков	
398525005500	SGM MVS 110-08-01	2	8	20	40	48	-	4	8 + 15	M 6	0,7	
398525010300	SGM MPS 110-10-01	1	8	25	32	54	-	-	10 + 14	M 8	0,8	
398525013100	SGM MVS 110-10-01	2	10	25	31	55	-	4	13 + 14	M 8	0,7	
398525014400	SGM MVS 110-10-02	2	10	22	47	55	-	4	13 + 14	M 8	0,8	
398525015700	SGM MVS 135-10-01	2	10	25	32	57	-	4	10 + 18	M 8	0,7	
398525016000	SGM MVS 135-10-02	2	10	22	47	55	-	4	10 + 18	M 8	0,9	
398525017200	SGM MVS 135-10-03	2	10	22	47	55	-	4	10 + 19	M 8	0,9	
398525020500	SGM MPS 110-11-01	1	11	25	32	46	-	-	8,5 + 16	M 8	0,6	
398525021800	SGM MPS 130-11-01	1	11	26	30	55	-	-	10 + 15	M 8	0,8	
398525024600	SGM MPS 160-11-01B	3	11	30	55	67	27	-	17 + 20	M 8	2,2	
398525027400	SGM MVS 160-11-01B	4	11	35	40	77	27	3	10 + 18 + 18	M 8	1,8	
398525031000	SGM MPS 160-12-02	1	12	32	32	72	-	-	15 + 20	M 10	1,3	
398525030700	SGM MPS 160-12-01	1	12	35	60	72	-	-	15 + 20	M 10	2,8	
398525034800	SGM MVS 160-12-01	2	12	32	32	82	-	4	15 + 20	M 10	1,5	
398525035000	SGM MVS 160-12-02	2	12	35	60	82	-	4	15 + 20	M 10	3,1	
398525038900	SGM MPS 200-14-02	1	14	35	40	95	-	-	24 + 25	M 12	2,4	
398525037600	SGM MPS 200-14-01	1	14	35	60	95	-	-	24 + 25	M 12	3,7	
398525039100	SGM MPS 200-14-03	1	14	38	80	95	-	-	24 + 25	M 12	5,9	
398525045200	SGM MVS 200-14-01	2	14	35	38	102	-	4	20 + 25	M 12	2,6	
398525046500	SGM MVS 200-14-02	2	14	40	80	102	-	4	20 + 25	M 12	6,0	
398525047800	SGM MVS 200-14-03	2	14	40	100	100	-	4	20 + 25	M 12	7,4	
398525042400	SGM MPS 200-14-01B	3	14	35	60	89	34	-	18 + 26	M 10	3,6	
398525050000	SGM MVS 200-14-01B	4	14	40	42	102	34	3	16 + 22 + 22	M 10	3,0	
398525054100	SGM MPS 200-16-02	1	16	40	40	85	-	-	20 + 25	M 12	2,5	
398525053900	SGM MPS 200-16-01	1	16	40	60	86	-	-	20 + 25	M 12	3,9	
398525064300	SGM MVS 200-16-01	2	16	40	40	102	-	4	20 + 25	M 12	3,0	
398525059500	SGM MPS 250-16-05	1	16	40	42	110	-	-	30 + 30	M 12	3,6	
398525061500	SGM MPS 250-16-07	1	16	50	50	120	-	-	30 + 30	M 12	6,1	
398525055400	SGM MPS 250-16-01	1	16	38	60	90	-	-	15 + 30	M 12	4,1	
398525056700	SGM MPS 250-16-02	1	16	38	60	110	-	-	30 + 30	M 12	5,2	
398525060200	SGM MPS 250-16-06	1	16	50	80	90	-	-	15 + 30	M 12	7,1	
398525057000	SGM MPS 250-16-03	1	16	38	78	110	-	-	30 + 30	M 12	6,9	
398525058200	SGM MPS 250-16-04	1	16	40	100	120	-	-	30 + 30	M 12	9,6	
398525065600	SGM MVS 250-16-01	2	16	40	42	125	-	4	30 + 30	M 12	3,1	
398525067100	SGM MVS 250-16-03	2	16	40	60	125	-	4	30 + 30	M 12	5,7	
398525066900	SGM MVS 250-16-02	2	16	40	100	125	-	4	30 + 30	M 12	9,6	

1,5 mm x 60°

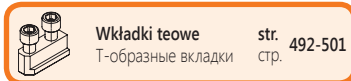



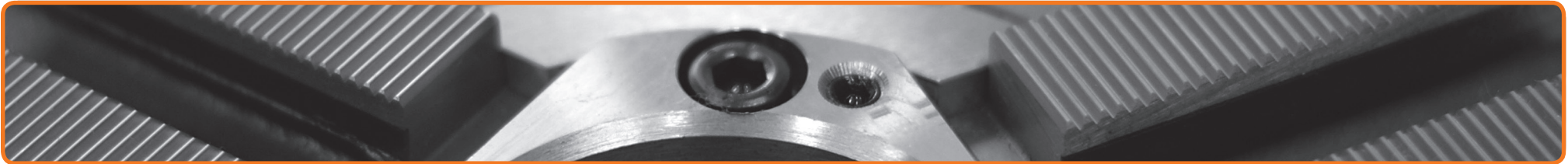

	SCHUNK	KITAGAWA	RÖHM	SMW-AUTOBLOK	MMK / MATSUMOTO	HOWA	
1,5 mm x 60°		B 04; HOB 04				HO 1 MA 4; HO 24 M 5	
		AS 110; B 204; B 205; HJ 4; N 04	KFD-HE 130; KFN 105		ZA 5-5		
		B 05; HOB 05					
		HJ 5; N 05					
						HO 27 M 4; HO 27 M 5	
			KFM 130; KFN 130-135				
			KFG 160; KFM 160; KFN 160; KFE 170		ZA 5-6-42		
		ROTA NCD 165-185; ROTA NCK 165; ROTA NC/NCF 165; HSL 165 ; ROTA NCK plus 165; ROTA NC plus 185; ROTA NCF plus 185	AS 165; B 06; BB 06; B 106; B 160; B 206; BB 206; B 7; B 07; HJA 5-6; HO 6; HOB 6; HOH 06; HOH 106; HOH 160; HOH 206; HOS 6; N 06; N 160	KFD-HE 170	AL-M 165; AN-M 165; BB-M 175; BH-M 165; BH-M FC 165; HB-M 165; HFKN-M 165; PB-M/PBI-M 165	YA 5-6-46; ZA 5-6-46	
		ROTA NCD 210; ROTA NCK 210; ROTA NC/NCF 210; HSL 210 ; ROTA NCK plus 210; ROTA NC plus 215; ROTA NCF plus 215	AS 210; B 08; B 108; B 200; B 208; BB 08; BB 208; HJA 6-8; HO 8; HOB 8; HOH 8; HOH 108; HOH 200; HOH 208; HOS 8; N 08; N 200	KFD-HE 210	AL-M 210; AN-M 210; BB-M 210; BH-M 210; BH-M FC 210; HB-M 210; HFKN-M 210; PB-M/PBI-M 210	ZA 6-8-52; ZA 6-8-66	
				KFE 215; KFG 215; KFM 215			
						HO 22 M 8; HO 24 M 8; HO 27 M 8; HO 37 M 8; HO 47 M 8; HO 7 MA 10; HO 15 M 10; HO 23 M 10	
	ROTA NCD 250; ROTA NCK 250; ROTA NC/NCF 250; HSL 250; ROTA NCK plus 250; ROTA NC plus 260; ROTA NCF plus 260	AS 250; B 10; B 110; B 210; B 250; BB 10; BB 210; HJA 6-10; HJA 8-10; HO 10; HOB 10; HOH 10; HOH 110; HOH 210; HOH 250; HOS 10; N 10; N 250	KFD-HE 254	AL-M 250; AN-M 250; BB-M 250; BH-M 250; BH-M FC 250; HBM 250; HFKN-M 260; PB-M/PBI-M 250	ZA 8-10-66; HA 8-10-66; ZA 6-10-75		

1

2

3

4

5

6

7

Dystrybucja: [unihurt.pl](http://unihurt.pl)



Zamówienia: [info@unihurt.pl](mailto:info@unihurt.pl) **SGM**



**SZCZĘKI GÓRNE MIĘKIE**  
 КУЛАЧКИ МЯГКИЕ НАКЛАДНЫЕ (СЫРЫЕ)

**METRYCZNA WIELKOŚĆ KĄTA ZĄBKÓW 1,5 mm x 60° LUB 3,0 mm x 60°**  
 МЕТРИЧЕСКОЕ ЗУБЧАТОЕ СОЕДИНЕНИЕ 1,5 мм x 60° ИЛИ 3,0 мм x 60°

- 1
- 2
- 3
- 4
- 5
- 6
- 7
- C

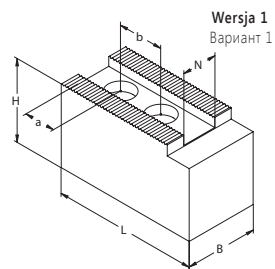

Wersja 1  
Вариант 1

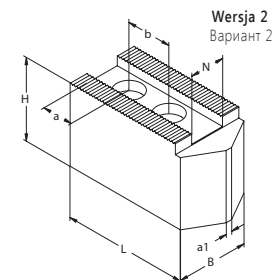

Wersja 2  
Вариант 2

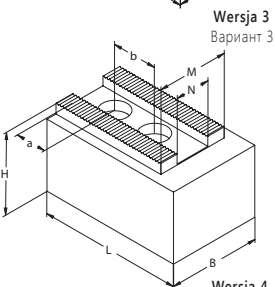

Wersja 3  
Вариант 3

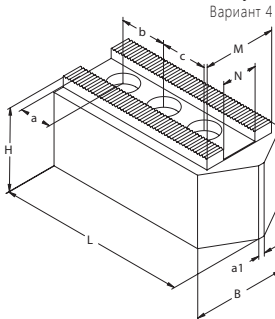

Wersja 4  
Вариант 4

Nr produktu Код продукта	Typ szczęk Тип кулачков	Wersja Вариант	N	B	H	L	M	a <sub>1</sub>	a + b	Śruby Винты		kg / kpl. кг / кпл.
										Винты	кг / кпл.	
398525071700	SGM MPS 250-18-02	1	18	50	50	108	-	-	24 + 30	M 14	5,2	
398525070400	SGM MPS 250-18-01	1	18	50	80	108	-	-	24 + 30	M 14	8,4	
398525077300	SGM MVS 250-18-01	2	18	50	50	120	-	6	25 + 30	M 14	5,6	
398525072000	SGM MPS 315-18-01	1	18	50	50	130	-	-	40 + 30	M 14	6,5	
398525073200	SGM MPS 315-18-02	1	18	50	80	130	-	-	40 + 30	M 14	10,4	
398525074500	SGM MPS 315-18-03	1	18	50	120	130	-	-	40 + 30	M 14	15,6	
398525078600	SGM MVS 315-18-01	2	18	50	50	145	-	10	30 + 30	M 14	7,0	
398525079900	SGM MVS 315-18-02	2	18	50	100	145	-	10	30 + 30	M 14	14,2	
398525082100	SGM MPS 250-20-01B	3	20	50	80	90	44	-	19 + 26	M 12	7,0	
398525083400	SGM MVS 250-20-01B	4	20	50	50	130	44	3,5	19 + 29,5 + 29,5	M 12	5,9	
398525090800	SGM MPS 350-21-01B	3	21	50	80	120	49	-	28 + 28	M 16	9,1	
398525085000	SGM MPS 315-21-01	1	21	50	60	111	-	-	25 + 35	M 16	6,2	
398525086200	SGM MPS 315-21-02	1	21	48	60	129	-	-	39 + 30	M 16	7,4	
398525088800	SGM MPS 315-21-04	1	21	48	78	129	-	-	39 + 30	M 16	10,0	
398525087500	SGM MPS 315-21-03	1	21	50	100	140	-	-	30 + 30	M 16	13,8	
398525092300	SGM MVS 315-21-01	2	21	48	48	145	-	10	30 + 30	M 16	6,9	
398525093600	SGM MVS 315-21-02	2	21	50	100	145	-	10	30 + 30	M 16	13,9	
398525096400	SGM MPS 400-22-01	1	22	60	80	156	-	-	36 + 60	M 20	14,2	
398525097700	SGM MPS 400-22-02	1	22	60	78	165	-	-	37 + 43	M 20	15,2	
398525098000	SGM MPS 400-22-03	1	22	60	120	165	-	-	37 + 43	M 20	22,8	
398525100200	SGM MVS 400-22-01	2	22	60	60	185	-	10	37 + 43	M 20	12,4	
398525131000	SGM MPS 200-14-10	1	14	40	40	90	-	-	20 + 25	M 12	2,7	
398525133600	SGM MPS 250-16-10	1	16	40	60	110	-	-	25 + 30	M 12	5,1	
398525135100	SGM MPS 315-18-10	1	18	50	80	130	-	-	40 + 30	M 14	10,2	
398525137700	SGM MPS 400-22-10	1	22	60	80	150	-	-	45 + 50	M 20	13,5	
398525139200	SGM MPS 500-25-01	1	25	80	80	195	-	-	50 + 60	M 20	25,3	
398525141200	SGM MPS 400-26-01	1	26	60	80	156	-	-	34 + 50	M 20	14,0	



Wkładki teowe  
Т-образные вкладки  
str. 492-501  
стр. 492-501



Materiał szczęk  
Материал кулачков



Wielkość kąta zębów  
Зубчатое соединение

Dystrybucja: unihurt.pl  
Zamówienia: info@unihurt.pl

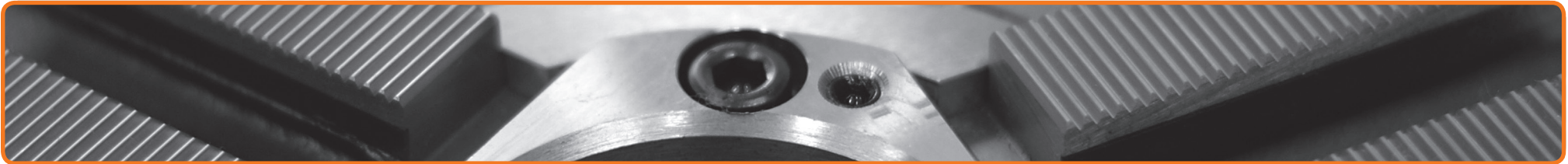

	SCHUNK	KITAGAWA	RÖHM	SMW-AUTOBLOK	MMK / MATSUMOTO	HOWA
1,5 mm x 60°						HO 22 M 10; HO 24 M 10; HO 27 M 10; HO 37 M 10; HO 47 M 10; HO 7 MA 12; HO 15 M 12; HO 23 M 12
	ROTA NC/NCF 315; HSL 315	B 12; B 300; HJA 6-12; HJA 8-12; HLA 6-15; HLA 8-15; HO 12; HOB 12; HOH 12; HOH 300; HOS 12; N 12; N 300			ZA 8-12-78	
			KFE 280; KFG 280; KFM 280; KFN 250-280			
			KFE 350; KFG 350; KFM 350; KFN 350			
						HO 27 M 12; HO 37 M 12; HO 47 M 12
	ROTA NCD 315; ROTA NCK 315; HSL 315; ROTA NCK plus 315; ROTA NC plus 315; ROTA NCF plus 315	B 112; B 212; BB 212; HOH 112; HOH 212	KFD-HE 315  KFD-HE 315	AL-M 315; AN-M 315; BB-M 305-315; BH-M 315; BH-M FC 315; GH-M 400; HB-M 305-315; HFKN-M 315; PB-M/PBI-M 315; RC-M 305-315-400		
	HJ 15; HJ 380; HJA 8-18; HJA 8-21; HJA 11-15; HLA 8-18; HLA 8-21					
ROTA NC/NCF 400; HSL 400	B 15; B 380; B 18; B 215; B 450; HOB 15; HOB 18; HOH 15; HOH 15-K; N15					
3,0 mm x 60°						HO 1 MA 8; HO 2 M 8
						HO 1 MA 10; HO 2 M 10
						HO 1 MA 12; HO 2 M 12
					ZA 11-15-120; HA 15-18-16; ZA 8-15-120	
		B 21; B 24; HJ 18; HJ 21; HJ 24; HOB 21; HOB 24; N 21; N 24				HO 1 MA 15; HO 1 M 18; HO 1 MA 21; HO 1 MA 24

- 1
- 2
- 3
- 4
- 5
- 6
- 7

Dystrybucja: [unihurt.pl](http://unihurt.pl)  
 Zamówienia: [info@unihurt.pl](mailto:info@unihurt.pl)

- 1
- 2
- 3
- 4
- 5
- 6
- 7
- C

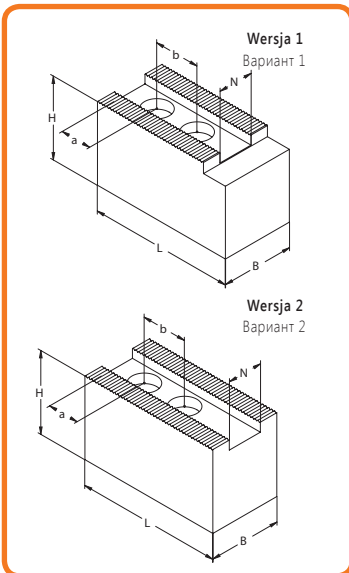

**SZCZĘKI GÓRNE MIĘKKIE**  
 КУЛАЧКИ МЯГКИЕ НАКЛАДНЫЕ (СЫРЫЕ)

**METRYCZNA WIELKOŚĆ KĄTA ZĄBKÓW 1,5 mm x 60°**  
 МЕТРИЧЕСКОЕ ЗУБЧАТОЕ СОЕДИНЕНИЕ 1,5 мм x 60°



Nr produktu Код продукта	Typ szczęk Тип кулачков	Wersja Вариант	N	B	H	L	a + b	Śruby	kg / kpl.
								Винты	кг / кпл.
398525276200	SGM MPA 160-12-01	1	12	35	50	72	15 + 20	M 10	0,8
398525277500	SGM MPA 200-14-01	2	14	40	60	90	20 + 25	M 12	1,4
398525279000	SGM MPA 250-16-02	1	16	40	60	90	25 + 25	M 12	1,4
398525278800	SGM MPA 250-16-01	1	16	40	60	110	25 + 30	M 12	1,8
398525281000	SGM MPA 250-18-01	1	18	50	60	108	24 + 30	M 14	3,6
398525280800	SGM MPA 315-18-01	1	18	50	80	130	40 + 30	M 14	2,2
398525282300	SGM MPA 315-21-01	1	21	50	80	130	40 + 30	M 16	3,5
398525283600	SGM MPA 400-22-01	1	22	60	80	145	40 + 43	M 20	4,5

1,5 mm x 60°

**Wkładki teowe** str. 492-501  
 Т-образные вкладки стр. 492-501

SGM MA

Dystrybucja: unihurt.pl  
 Zamówienia: info@unihurt.pl

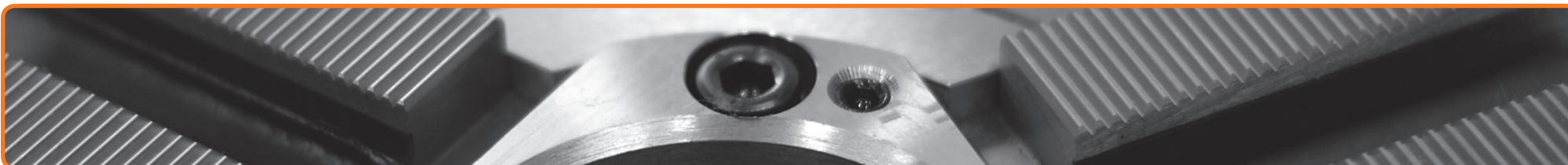

	SCHUNK	KITAGAWA	RÖHM	SMW-AUTOBLOK	HOWA
1,5 mm x 60°	ROTA NCK 165; HSL 165; ROTA NC/NCF 165; ROTA NCK plus 165; ROTA NCD 165-185; ROTA NC plus 185; ROTA NCF plus 185	AS 165; B 06; BB 06; B 106; B 160; B 206; BB 206; B 7; B 07; HJA 5-6; HO 6; HOB 6; HOH 06; HOH 106; HOH 160; HOH 206; HOS 6; N 06; N 160	KFD-HE 170	AL-M 165; AN-M 165; BB-M 175; BH-M 165; BH-M FC 165; HB-M 165; HFKN-M 165; PB-M/PBI-M 165	HO 7 MA 6; HO 15 M 6; HO 22 M 6; HO 24 M 6; HO 27 M 6; HO 37 M 6; HO 47 M 6
	ROTA NCK 210; HSL 210; ROTA NC/NCF 210; ROTA NCK plus 210; ROTA NC plus 215; ROTA NCF plus 215	AS 210; B 08; B 108; B 200; B 208; BB 208; BB 08; HJA 6-8; HO 8; HOB 8; HOH 8; HOH 108; HOH 200; HOH 208; HOS 8; N 08; N 200	KFD-HE 210	AL-M 210; AN-M 210; BB-M 210; BH-M 210; BH-M FC 210; HB-M 210; HFKN-M 210; PB-M/PBI-M 210	HO 7 MA 8; HO 15 M 8; HO 23 M 8  HO 22 M 8; HO 24 M 8; HO 27 M 8; HO 37 M 8; HO 47 M 8; HO 7 MA 10; HO 15 M 10; HO 23 M 10
	ROTA NCK 250; HSL 250; ROTA NC/NCF 250; ROTA NCK plus 250; ROTA NC plus 260; ROTA NCF plus 260	AS 250; B 10; B 110; B 210; BB 210; B 250; BB 10; HJA 6-10; HJA 8-10; HO 10; HOB 10; HOH 10; HOH 110; HOH 210; HOH 250; HOS 10; N 10; N 250	KFD-HE 254	AL-M 250; AN-M 250; BB-M 250; BH-M 250; BH-M FC 250; HBM 250; HFKN-M 260; PB-M/PBI-M 250	HO 22 M 10; HO 24 M 10; HO 27 M 10; HO 37 M 10; HO 47 M 10; HO 7 MA 12; HO 15 M 12; HO 23 M 12  HO 22 M 10; HO 24 M 10; HO 27 M 10; HO 37 M 10; HO 47 M 10; HO 7 MA 12; HO 15 M 12; HO 23 M 12
	ROTA NC/NCF 315; HSL 315	B 12; B 300; HJA 6-12; HJA 8-12; HLA 6-12; HLA 6-15; HLA 8-15; HO 12; HOB 12; HOH 12; HOH 300; HOS 12; N 12; N 300	KFD-HE 315	AL-M 315; AN-M 315; BB-M 305-315; BH-M 315; BH-M FC 315; HB-M 305-315; HFKN-M 315; PB-M/PBI-M 315; RC-M 305-315	
	ROTA NCK 315; HSL 315; ROTA NCD 315; ROTA NCK plus 315; ROTA NC plus 315; ROTA NCF plus 315	B 112; B 212; BB 212; HOH 112; HOH 212			
	ROTA NC/NCF 400	B 15; B 380; B 18; B 215; B 450; HOB 15; HOB 18; HOH 15; HOH 15-K; N15			

1

2

3

4

5

6

7

Dystrybucja: unihurt.pl



Zamówienia: info@unihurt.pl

SGM



**SZCZĘKI GÓRNE MIĘKKIE**  
 КУЛАЧКИ МЯГКИЕ НАКЛАДНЫЕ (СЫРЫЕ)

**CAŁOWA WIELKOŚĆ KĄTA ZĄBKÓW 1/16" x 90°**  
 ДЮЙМОВОЕ ЗУБЧАТОЕ СОЕДИНЕНИЕ 1/16" x 90°

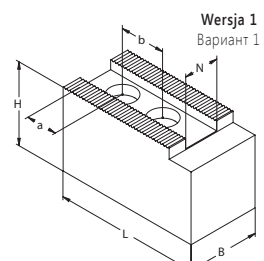

Wersja 1  
 Вариант 1

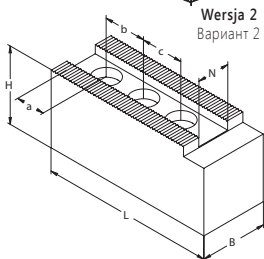

Wersja 2  
 Вариант 2

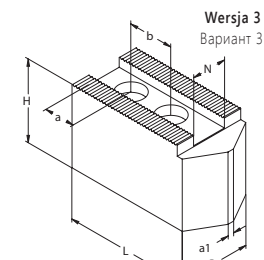

Wersja 3  
 Вариант 3

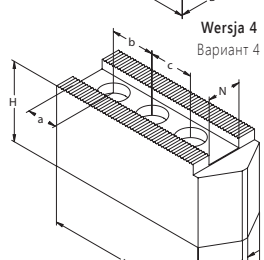

Wersja 4  
 Вариант 4

Nr produktu Код продукта	Typ szczęk Тип кулачков	Wersja Вариант	N	B	H	L	a <sub>1</sub>	Śruby	a + b (+c)	kg / kpl. кг / кпл.
								Винты		
398525150100	SGM CPS 110-08-01	1	8	20	40	50	-	M 6	26,5 + 12	0,7
398525151400	SGM CPS 110-08-02	1	8	20	40	55	-	M 9 x 1	11 + 14	0,7
398525158300	SGM CVS 110-10-01	4	10	25	30	55	3	M 6	11 + 12 + 12	0,7
398525153000	SGM CPS 110-10-01	2	10	22	47	53	-	M 6	9 + 12 + 12	0,9
398525159600	SGM CVS 110-10-02	4	10	32	32	62	3	M 6	9 + 12 + 12	1,1
398525156800	SGM CVS 130-10-01	3	10	25	32	45	5	M 8	12 + 15	0,6
398525155500	SGM CVS 140-10-01	3	10	30	45	70	4	M 10	13 + 19	1,5
398525157000	SGM CVS 140-10-02	4	10	30	50	70	3	M 8	20 + 15 + 15	1,8
398525162900	SGM CPS 130-11-01	1	11	30	40	55	-	M 8	10 + 18	1,2
398525164400	SGM CPS 130-12-01	1	12	30	38	55	-	M 8	10 + 16	1,2
398525167200	SGM CPS 130-12-02	1	12	32	32	60	-	M 10	12 + 19	1,0
398525168500	SGM CPS 160-12-01	1	12	30	38	55	-	M 8	9 + 15	1,2
398525169800	SGM CPS 160-12-02	1	12	30	55	55	-	M 8	9 + 15	1,7
398525172000	SGM CVS 160-12-01	3	12	35	40	72	3	M 8	12 + 15	1,9
398525165700	SGM CPS 200-12-01	1	12	30	55	84	-	M 12	18 + 21	2,3
398525166000	SGM CPS 200-12-02	1	12	35	60	90	-	M 12	14 + 21	3,4
398525171800	SGM CVS 200-12-01	3	12	35	60	95	4	M 12	14 + 21	3,4
398525175900	SGM CPS 160-14-01	1	14	35	60	68	-	M 10	15 + 20	2,6
398525178700	SGM CVS 160-14-01	3	14	35	38	80	4	M 10	15 + 20	2,0
398525176100	SGM CPS 160-14-02	1	14	35	40	72	-	M 12	15 + 21	1,7
398525181000	SGM CPS 250-16-01	1	16	40	60	111	-	M 16	18 + 29	4,7
398525182200	SGM CPS 250-16-02	1	16	40	80	111	-	M 16	18 + 29	6,3
398525185000	SGM CVS 250-16-01	3	16	40	60	120	4	M 16	18 + 29	4,9
398525188900	SGM CPS 160-17-01	1	17	60	60	70	-	M 12	12 + 22	3,3 *
398525191100	SGM CPS 160-17-03	1	17	38	60	70	-	M 12	15 + 22	3,0
398525189100	SGM CPS 160-17-02	1	17	35	40	70	-	M 12	15 + 22	1,6
398525198000	SGM CVS 160-17-01	3	17	35	38	78	4	M 12	15 + 22	1,8
398525193700	SGM CPS 200-17-03	1	17	40	80	90	-	M 14	18 + 24	4,9
398525194000	SGM CPS 200-17-04	1	17	38	60	70	-	M 12	12 + 19	2,9
398525192400	SGM CPS 200-17-02	1	17	38	60	90	-	M 12	25 + 22	4,1
398525190900	SGM CPS 200-17-01	1	17	40	40	90	-	M 12	25 + 22	2,7
398525199300	SGM CVS 200-17-01	3	17	35	40	98	4	M 12	15 + 22	2,4
398525195200	SGM CPS 250-17-01	1	17	38	60	90	-	M 12	12 + 19	4,0

1/16" x 90°

\* 2 szczęki w zestawie • 2 кулачки в комплекте



Wkładki teowe  
 Т-образные вкладки  
 str. 492-501  
 стр.



Materiał szczęk  
 Материал кулачков



Wielkość kąta ząbków  
 Зубчатое соединение





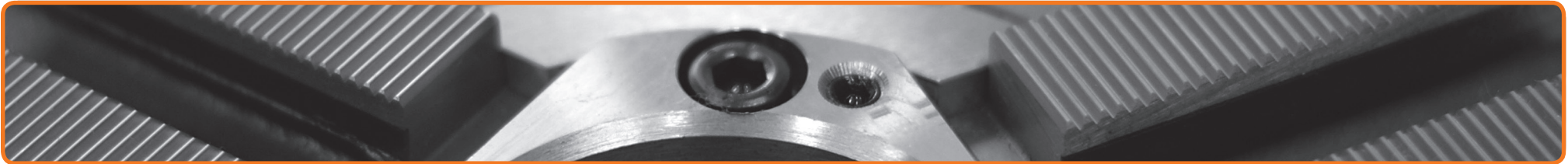

SCHUNK	FORKARDT	RÖHM	SMW-AUTOBLOK	BERG
			HFKS 110; HFKN-D 110	
				KH 110
HSG 140; ROTA NCD 130		KFD 110-125; KFD 140; KFD-HS 125-130-140		
		KFD-HS 110; KFD-HE 130-140		
				KH 140; KH 160
ROTA TP 125; TP 125		KFD-HE 140	SP/STP 125 bis Bj. 98; STWP 125; HFKS 130-32	
		LVE 125; LVE 160; KFD 130; KFH 140	AL-D/AN-D 125; BH-D 130; HB-D 130; KDV 130; PB-D 130; PBI-D 130; SP/STP 125 ab Bj. 98; BB-D 140	KF 130
	KTHS 130-140; QLC 140; QLK 140			
HSG 160; ROTA NCD 160-165		KFD-HE 170; KFD-HS 160-175		
				KH 175; KH 200
ROTA TP 160; TP 160; ROTA NCK plus 165; ROTA NC plus 185; ROTA NCF plus 185; ROTA NCR 250-315			AL-D/AN-D 165; BB-D 175; BH-D/BHD-FC 165; GHD-FC 165; GHDN 165; HBD 165; HFKN-D 165; HYDN-S 180; PB-D/PBI-D 165; SP/STP/STWP 160	
	KTHS 160-175			
HSG 315				KH 250; KH 315
ROTA 2B 160	2BLE-PS 160-200; 2BLEF 200			
HSL 165; ROTA NC 165; ROTA NCD 185; ROTA NCF 165; ROTA NCO 165; TH/THF 165	KGH/KGHF 160-175; KL/KS 160; KSF 175; KSH/KSPS 160; KT/KTG/KTN 160; KTH 160-175; NH/NHF 160-175; QLC 160-175; QLK 160-175; UVE 160	KFD 160; KFD-AF 160; KFD-HF 160; KFH 160; KFH-F 160; KFH-G 160; KFH-NC 160; LVE 160; SPD 160; SPO 160	HFK/HFKS 160; KDV/KDVG 160; KFMF 160; KVF 160	HES 160; HESF 160; KF 160
	KTHS 200-250-315			
HSG 200		KFD-HS 200		
HSL 210; ROTA NC 210; ROTA NCD 185-210; ROTA NCF 210; ROTA NCO 210; ROTA TP 200; TH/THF 210; TP 200; ROTA NCK plus 210-250; ROTA NC plus 215; ROTA NCF plus 215	KG/KGH/KGHF 200; KL/KLNC/KP 200; KS/KSHF 200; KSF/KSH/KSPS 200; KT/KTH/KTG/KTGF/KTN 200; NH/NHF 200; QLC/QLK 200; QLC-KS/QLK-KS 200-250; KL/KS 250 (Monforts); NHF 250-290 (Index); UVE 200-250; KS 250	KFD 200; KFD-AF 200; KFD-HE 210; KFD-HF 200; KFH 200; KFH-F 200; KFH-G 200; KFH-NC 200; KFL 250; LVE 200; SPD 215; SPO 215	AL-D/AN-D 210; BB-D 210; BH-D/BH-D FC 210; CD 200; GHD-FC/GHDN 210; HB-D 210; HDB 220; HDL 200; HDN 200-220-250S; HFK/HFKS 200; HFKN-D 210; HYDN-S 210-225; KFMF 200; KVF 200; LP 205; PB-D/PBI-D 210; RC-D 210; KDV/KDVG 200-250; ODL/ODN 200-220; SP/STP/STWP 200	HES 200; HESF 200; KF 200; KHFF 200
HSG 250		KFD-HS 250		

1/16" x 90°

1

2

3

4

5

6

7

Dystrybucja: unihurt.pl



Zamówienia: info@unihurt.pl

SGM



- 1
- 2
- 3
- 4
- 5
- 6
- 7
- C

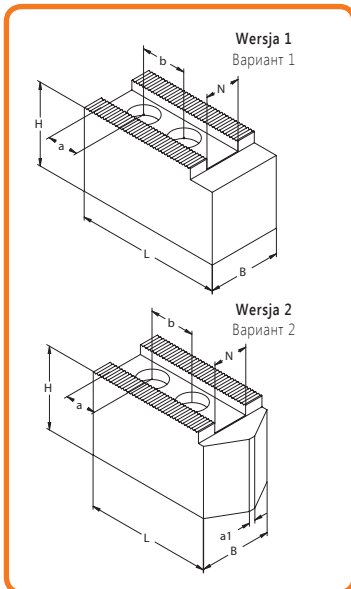

**SZCZĘKI GÓRNE MIĘKKIE**  
 КУЛАЧКИ МЯГКИЕ НАКЛАДНЫЕ (СЫРЫЕ)

**CAŁOWA WIELKOŚĆ KĄTA ZĄBKÓW 1/16" x 90° LUB 3/32" x 90°**  
 ДЮЙМОВОЕ ЗУБЧАТОЕ СОЕДИНЕНИЕ 1/16" x 90° ИЛИ 3/32" x 90°



	Nr produktu Код продукта	Typ szczęk Тип кулачков	Wersja Вариант	N	B	H	L	a <sub>1</sub>	Śruby	a + b (+c)	kg / kpl.
									Винты		кг / кпл.
1/16" x 90°	398525202900	SGM CPS 200-21-01	1	21	80	80	95	-	M 16	22 + 28	8,1 *
	398525204400	SGM CPS 250-21-02	1	21	48	78	120	-	M 16	30 + 28	9,1
	398525203100	SGM CPS 250-21-01	1	21	50	60	95	-	M 16	15 + 28	5,1
	398525208500	SGM CVS 250-21-01	2	21	48	48	120	4	M 16	20 + 28	5,3
	398525209800	SGM CVS 250-21-02	2	21	48	48	140	4	M 16	30 + 28	6,4
	398525205700	SGM CPS 315-21-01	1	21	48	60	105	-	M 16	15 + 25	5,6
	398525212000	SGM CPS 250-25,5-01	1	25,5	80	80	110	-	M 20	20 + 35	8,9 *
	398525213300	SGM CPS 315-25,5-01	1	25,5	80	80	125	-	M 20	28 + 35	10,4 *
398525214600	SGM CPS 400-25,5-01	1	25,5	80	80	150	-	M 20	28 + 35	12,8 *	
3/32" x 90°	398525249500	SGM CPS 400-20-01	1	20	50	80	150	-	M 20	31 + 38	10,7
	398525254300	SGM CPS 400-25,5-12	1	25,5	60	90	155	-	M 20	30 + 35	15,9
	398525251500	SGM CPS 400-25,5-10	1	25,5	60	80	140	-	M 20	30 + 35	12,5
	398525252800	SGM CPS 400-25,5-11	1	25,5	60	100	155	-	M 18	35 + 40	18,2
	398525253000	SGM CPS 500-25,5-01	1	25,5	60	100	195	-	M 18	37 + 40	23,7
	398525257100	SGM CPS 630-30-01	1	30	75	90	240	-	M 24	42 + 65	31,9
	398525258400	SGM CPS 800-30-01	1	30	75	90	300	-	M 24	68 + 65	41,0

\* 2 szczęki w zestawie • 2 кулачки в комплекте

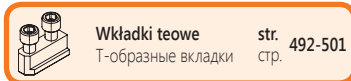

SGM CS

Dystrybucja: unihurt.pl  
 Zamówienia: info@unihurt.pl

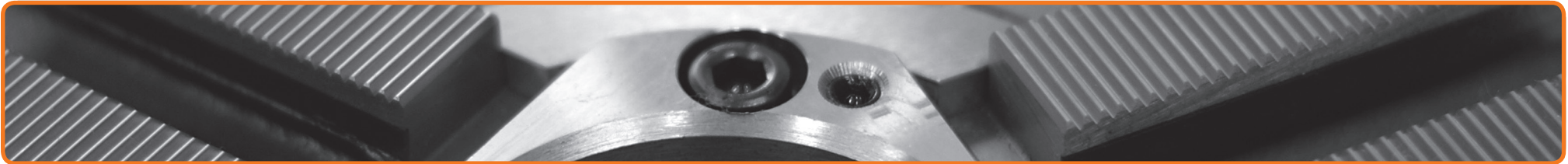

	SCHUNK	FORKARDT	RÖHM	SMW-AUTOBLOK	BERG
1/16" x 90°	ROTA 2B 200	2BLE 200-250 (Monforts); 2BLN 200	KFA 200	KZF 200; KZF-ES 200; 2 CLD 200; US-2 CLD 200	
	HSL 250-315; ROTA NC 250-315; ROTA NC plus 260-315; ROTA NCD 250-315; ROTA NCF 250-315; ROTA NCF plus 260-315; ROTA NCK plus 315; ROTA NCO 260-315; ROTA TP 250-315-350; ROTA NCR 500-630-800; TH/THF 250-315; TP 250-315; ROTA EP 500	KG 250-315; KL 250; KLNC/KP 250-315; KS 315-400; KSH/KSHF 250-400; KSPS 250-300; KT/KTG/KTGF/KTN 250-315; NH/NHF 250-315; NHF 257-290; NHF 400 (Index); QLC/QLK 250-315; QLC-KS/QLK-KS 315-400; UVE 315	KFD 250-315; KFD-AF 250-315; KFD-HE 254-315; KFD-HF 250-315; KFH 250-315; KFH-F 250-315; KFH-G 250-315; KFH-NC 250-315; KFL 315-400; LVE 250-305-315; SPD 300; SPO 300	AL-D/AN-D 250-315; BB-D 250-315; BH-D 250-315; BH-D FC 250-400; CD 250-315; GHD-FC/GHDN 250-305-315-400; GHD 400; HB-D 250-315; HDB 300; HDL/HDN 250-315-400; HFK/HFKS 250-315; HFKN-D 260-315; HYDN-S 250-315; KDV/KDVG 315-400; KFMF 250-315; KFV 250-315; LP 250; ODL/ODN 250-315-400; PB-D/PBI-D 250-315; RCD 250-305-400; SP 250-280-315-350; STP 250-280-315	HES 250; HESF 250; KF 250; KHFF 250; HES 315; HESF 315; KF 315; KHFF 315
	HSG 315		KFD-HS 315		
	ROTA 2B 250	2BLE 250-315; 2BLN 250-315	KFA 250-315	KZF 250-315; KZF-ES 250-315; 2 CLD 250-315; US-2 CLD 250-315	
	ROTA 2B 315				
ROTA 2B 400					
3/32" x 90°					KH 400; KH 500; KH 630
	HSG 400-500; HSL 400; ROTA NC 400-500; ROTA NCD 400-500; ROTA NCF 400-500; ROTA NCO 400-500-630-800; TH/THF 400-500; ROTA NCR 1000	KG 400-500; KL/KLNC 400-500; KP 400-500; KS 500-630; KSH 500; KSHF 630; KS-L 630; KSPS 400; KT/KTGF 400-630; KTG/KTN 400-500; NH/NHF 400-630; QLC/QLK 400; UVE 400-800	KFD 400-500-630-800; KFD-HE 400; KFD-HF 400; KFD-HF 500-630; KFD-HS 400-500; KFH 400-500; KFH-F 400-500; KFH-G 400-500; KFH-NC 400-500; KFL 500-600; LVE 400-500-630-800	AL-D/AN-D 400; BB-N 400-460-500 ab Bj. 98; BH-D 400-450; BHD-FC 500-630; GHD 500-610-640-800; HFK/HFKS 400-500; HFKN-D 400-500; ILD/IND 500-630-800; KDV/KDVG 500; KFV 400-500-630-800; RCD 500-630; BHD 630-800	HES 400; HESF 400; KF 400; KHFF 400; HES 500; HESF 500; KF 500; HES 630; HESF 630; KF 630
	ROTA EP 380; ROTA TB 400; ROTA TB-LH 400; TB 400			BB 400; BB 400 ES; LP 380-460; STP 400	
	ROTA EP 460; ROTA EP-LH 460; ROTA TB 500-610; ROTA TB-LH 500-610; ROTA TB-LH 630-265; TB 500			BB 500; BB 500 ES; BB 630-265 ES; LP 500; STP 500	
	ROTA NC 630-800; ROTA TB 630; ROTA TB 630-325 LH; TB 630			BB 630; BB 630-325 ES; STP 630; BB-N 630	
ROTA TB 800-1000; ROTA TB-LH 850-1000-1200		KFD 1000-1200	BB 800-1000; BB 850-1000 ES; BB-N 800-1000; STP 800		

1

2

3

4

5

6

7

Dystrybucja: unihurt.pl



Zamówienia: info@unihurt.pl

SGM

- 1
- 2
- 3
- 4
- 5
- 6
- 7
- C

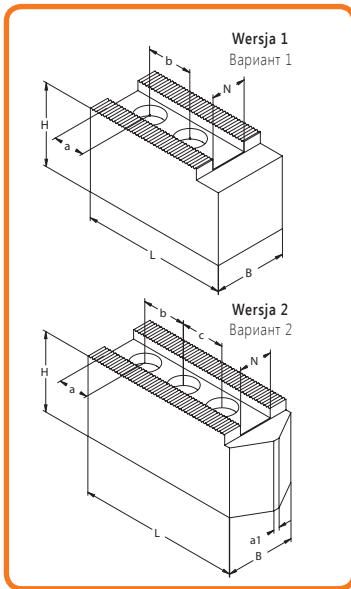

**SZCZĘKI GÓRNE MIĘKKIE**  
 КУЛАЧКИ МЯГКИЕ НАКЛАДНЫЕ (СЫРЫЕ)

**CALOWA WIELKOŚĆ KĄTA ZĄBKÓW 1/16" x 90° LUB 3/32" x 90°**  
 ДЮЙМОВОЕ ЗУБЧАТОЕ СОЕДИНЕНИЕ 1/16" x 90° ИЛИ 3/32" x 90°



Nr produktu Код продукта	Typ szczęk Тип кулачков	Wersja Вариант	N	B	H	L	a <sub>1</sub>	a + b (+c)	Śruby	kg / kpl.
									Винты	кг / клп.
398525285100	SGM CVA 130-10-01	2	10	25	45	53	3	9 + 12 + 12	M 6	0,3
398525284900	SGM CPA 160-10-01	1	10	25	50	70	-	13 + 19	M 10	0,5
398525286400	SGM CPA 130-12-01	1	12	30	38	55	-	10 + 16	M 8	0,4
398525288000	SGM CPA 160-12-01	1	12	30	55	70	-	9 + 15	M 8	0,8
398525287700	SGM CPA 200-12-01	1	12	30	60	84	-	18 + 21	M 12	0,9
398525289200	SGM CPA 160-14-01	1	14	35	60	80	-	15 + 20	M 10	1,1
398525290000	SGM CPA 250-16-01	1	16	40	60	111	-	18 + 29	M 16	1,6
398525291200	SGM CPA 160-17-01	1	17	40	60	70	-	15 + 22	M 12	1,0
398525293800	SGM CPA 200-17-02	1	17	40	60	90	-	12 + 19	M 12	1,4
398525292500	SGM CPA 200-17-01	1	17	40	60	90	-	25 + 22	M 12	1,4
398525294000	SGM CPA 250-21-01	1	21	50	80	120	-	30 + 28	M 16	3,1
398525295300	SGM CPA 400-25,5-01	1	25,5	60	100	155	-	30 + 35	M 20	6,1

**Wkładki teowe**  
 Т-образные вкладки str. 492-501  
 str. 492-501

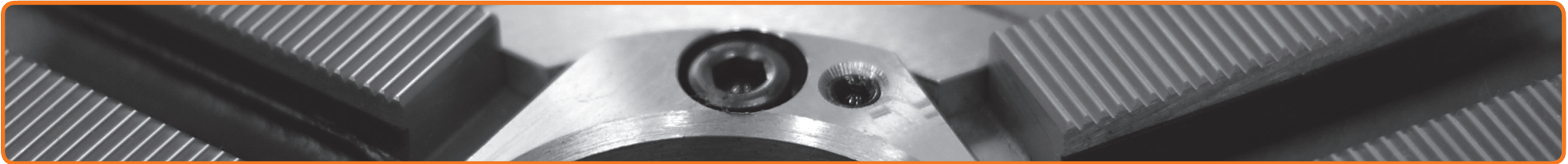

	SCHUNK	FORKARDT	RÖHM	SMW-AUTOBLOK	BERG
1/16" x 90°	HSG 140; ROTA NCD 130		KFD 110-125-140; KFD-HS 125-130-140; KFD-HS 110; KFD-HE 130		KH 140; KH 160
			LVE 125; LVE 160; KFD 130; KFH 140	AL-D/AN-D 125; BH-D 130; HB-D 130; KDV 130; PB-D/PBI-D 130; SP/STP 125 ab Bj. 98; BB-D 140	KF 130
	HSG 160; ROTA NCD 160-165	KGH/KGHF 160-175; KL/KS 160; KSF 175; KSH/KSPS 160; KT/KTG/KTN 160; KTH 160-175; NH/NHF 160-175; QLC 160-175; QLK 160-175; UVE 160	KFD-HE 170; KFD-HS 160-175		KH 175; KH 200
	ROTA TP 160; TP 160; ROTA NCK plus 165; ROTA NCR 250-315; ROTA NC plus 185; ROTA NCF plus 185			AL-D/AN-D 165; BB-D 175; BH-D/BHD-FC 165; GHD-FC 165; GHDN 165; HB-D 165; HFKN-D 165; HYDN-S 180; PB-D/PBI-D 165; SP/STP/STWP 160	HES 200; HESF 200; KF 200; KHFF 200
	HSL 165; ROTA NC 165; ROTA NCD 185; ROTA NCF 165; TH/THF 165; ROTA NCO 165		KFD 160; KFD-AF 160; KFD-HF 160; KFH 160; KFH-F 160; KFH-G 160; KFH-NC 160; LVE 160; SPD 160; SPO 160	HFH/HFKS 160; KDV/KDVG 160; KFMF 160; KFV 160	HES 160; HESF 160; KF 160
	HSG 200; HSG 250		KFD-HS 200-250		
3/32" x 90°	HSL 210; ROTA NC 210; ROTA NCD 185-210; ROTA NCF 210; ROTA NCO 210; ROTA TP 200; TH/THF 210; TP 200; ROTA NCK plus 210-250; ROTA NC plus 215; ROTA NCF plus 215	KG/KGH/KGHF 200; KL/KLNC/KP 200; KS/KSHF 200-250; KSF/KSH/KSPS 200; KT/KTH/KTG/KTGF/KTN 200; NH/NHF 200; QLC/QLK 200; QLC-KS/QLK-KS 200-250; KL/KS 250 (Monforts); NHF 250-290 (Index); UVE 200-250	KFD 200; KFD-AF 200; KFD-HE 210; KFD-HF 200; KFH 200; KFH-F 200; KFH-G 200; KFH-NC 200; KFL 250; LVE 200; SPD 215; SPO 215	AL-D/AN-D 210; BB-D 210; BH-D/BHD-FC 210; CD 200; GHD-FC/GHDN 210; HB-D 210; HDB 220; HDN 200-220-250S; HFH/HFKS 200; HFKN-D 210; HYDN-S 210-226; KFMF 200; KFV 200; LP 205; PB-D/PBI-D 210; RCD 210; KDV/KDVG 200-250; ODL/ODN 200-220; SP/STP/STWP 200	HES 200; HESF 200; KF 200; KHFF 200
	HSL 250-315; ROTA NC 250-315; ROTA NC plus 260-315; ROTA NCD 250-315; ROTA NCF 250-315; ROTA NCF plus 260-315; ROTA NCO 260-315; ROTA TP 250-315; HSG 315; TH/THF 250-315; TP 250-315; ROTA EP 500; ROTA NCK plus 315; ROTA NCR 500-630-800	KG 250-315; KL 250; KLNC/KP 250-315; KS 315-400; KSH/KSHF 250-400; KSPS 250-300; KT/KTG/KTGF/KTN 250-315; NH/NHF 250-315; NHF 250-290; NHF 400 (Index); QLC/QLK 250-315; QLC-KS/QLK-KS 315-400; UVE 315	KFD 250-315; KFD-AF 250-315; KFD-HE 254-315; KFD-HF 250-315; KFD-HS 315; KFH 250-315; KFH-F 250-315; KFH-G 250-315; KFH-NC 250-315; KFL 315-400; LVE 250-305-315; SPD 300; SPO 300	AL-D/AN-D 250-315; BB-D 250-315; BH-D 250-315; BHD-FC 250-400; CD 250-315; GHD-FC/GHDN 250-305-315-400; GHD 400; HB-D 250-315; HDB 300; HDL/HDN 250-315-400; HFH/HFKS 250-315; HFKN-D 260-315; HYDN-S 250-315; KDV/KDVG 315-400; KFMF 250-315; KFV 250-315; LP 250; ODL/ODN 250-315-400; PB-D/PBI-D 250-315; RCD 250-305-400; SP 250-280-305-350; STP 250-280-315	HES 250; HESF 250; KF 250; KHFF 250; HES 315; HESF 315; KF 315; KHFF 315
	HSG 400-500; HSL 400; ROTA NC 400-500-630-800; ROTA NCD 400-500; ROTA NCF 400-500; ROTA NCO 400-500; TH/THF 400-500; ROTA NCR 1000	KG 400-500; KL/KLNC 400-500; KP 400-500; KS 500-630; KSH 500; KSHF 630; KS-L 630; KSPS 400; KT/KTG 400-630; KTG/KTN 400-500; NH/NHF 400-630; QLC/QLK 400; UVE 400-800	KFD 400-500-630-800; KFD-HE 400; KFD-HF 400-500-630; KFD-HS 400-500; KFH 400-500; KFH-F 400-500; KFH-G 400-500; KFH-NC 400-500; KFL 500-600; LVE 400-500-630-800	AL-D/AN-D 400; BB-N 400-460-500 ab Bj. 98; BH-D 400-450; BHD-FC 500-630; GHD 500-610-640-800; HFH/HFKS 400-500; HFKN-D 400-500; ILD/JND 500-630-800; KDV/KDVG 500; KFV 400-500-630-800; RCD 500-630; BH-D 630-800	HES 400; HESF 400; KF 400; KHFF 400; HES 500; HESF 500; KF 500; HES 630; HESF 630; KF 630



- 1
- 2
- 3
- 4
- 5
- 6
- 7
- C

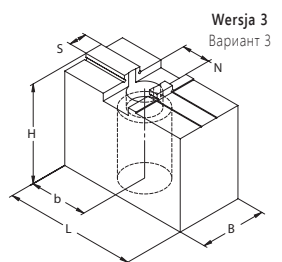
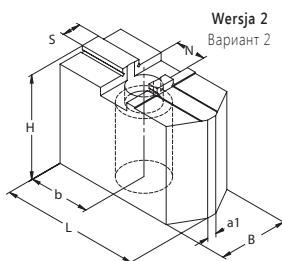
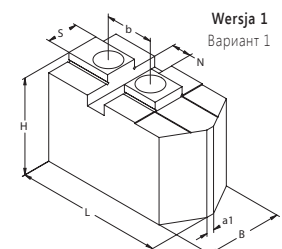

**SZCZĘKI GÓRNE MIĘKKIE**  
 КУЛАЧКИ МЯГКИЕ НАКЛАДНЫЕ (СЫРЫЕ)

**Z WPUSTEM I ROWKIEM**  
 С СИСТЕМОЙ ПАЗ-ШПОНКА

Nr produktu	Typ szczęk	Wersja	N	S	B	H	L	a <sub>1</sub>	b	Śruby		kg / kpl.
										Код продукта	Тип кулачков	
398525419100	SGM Z2VS 85-01	2	8	8	22	30	40	3	11	M 8	0,4	
398525405900	SGM Z1VS 110-01	1	8	8	25	30	51	3	15	M 6	0,6	
398525408700	SGM Z1VS 110-20	1	8	8	22	47	55,3	1	17	M 8	0,8	
398525409000	SGM Z1VS 130-01	1	8	10	25	30	60	3	22	M 8	0,7	
398525406100	SGM Z1VS 110-10	1	10	10	22	30	53	3	17	M 8	0,5	
398525410700	SGM Z1VS 160-01	1	10	16	40	60	76	4	25	M 12	3,0	
398525411000	SGM Z1VS 200-01	1	12	16	40	60	94	8	30	M 12	4,0	
398525413500	SGM Z1VS 200-21	1	12	16	40	60	94	8	30	M 12	2,6 *	
398525422400	SGM Z2VS 130-01	2	13	8	30	45	60	4	26,5	M 12	1,4	
398525421100	SGM Z2PS 125-01	3	16	14	40	48	60	-	29	M 12	2,3 *	
398525423700	SGM Z2PS 160-01	3	18	18	60	60	76	-	35	M 16	5,6 *	
398525412200	SGM Z1VS 250-01	1	16	20	50	80	117	12	40	M 16	8,2	
398525414800	SGM Z1VS 250-21	1	16	20	50	80	117	12	40	M 16	5,5 *	
398525415000	SGM Z1VS 315-01	1	16	20	50	80	149	6	50	M 16	10,9	
398525416300	SGM Z1VS 315-21	1	16	20	50	80	149	6	50	M 16	7,4 *	
398525417600	SGM Z1VS 400-01	1	18	22	60	100	180	12	60	M 16	21,1	
398525418900	SGM Z1VS 400-21	1	18	22	60	100	180	12	60	M 16	14,7 *	

\* 2 szczęki w zestawie • 2 кулачки в комплекте

Dystrybucja: unihurt.pl



Zamówienia: info@unihurt.pl

SGM ZS

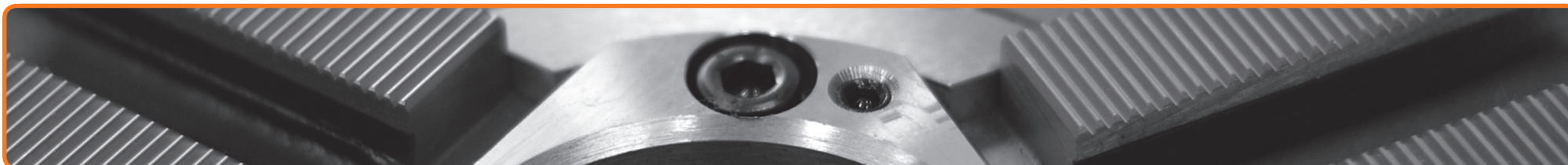

	SCHUNK	FORKARDT	RÖHM	SMW-AUTOBLOK	BERG
Ø 85 - 400 mm			KFD 85		
			KFD 110; KFD 125	HFK 110; HFKS 110	
	TH 110-25,5		KFD 110; KFD-HS 110		
	ROTA NCR 165	KGH 130-30	KFD-HS 130		
	HSG 110		KFD-HS 110		
	ROTA NCO 165	KG 160; KT 160	KFD 160; KFD-HS 160-175; KF/SK 160		GFK 2/157; GFK 3/157; KF 3/160; KFN 2/160
	ROTA NCO 200-210	KG 200; KT 200; KTG 200	KFD 200; KFD-HN 220; KFD-HS 200; KF/SK 200		GFK 2/187; GFK 3/187; KF 3/200; KFN 2/200
	ROTA 2B 200				
		KG 130; KS 130; KS/PK 130	KFD 130-140; KF/SK 130		
	ROTA 2B 125	2BLE 125; 2BLN 125	KFA 125; KFD-G 125	CL-C 125; KZF 125; KZF-ES 125	
	ROTA 2B 160	2BLE 160; 2BLEPK 160; 2BLN 160	KFA 160; KFD-G 160	CL-C 160; KZF 160; KZF-ES 160	
	ROTA NCO 250-260	KG 250; KT 250; KTG 250; KTN 250	KFD 250; KFD-HN 280; KFD-HS 250		KF 3/250; KFN 2/250; GFK 2/280; GFK 3/280
	ROTA 2B 250				
	ROTA NCO 315		KFD 315; KFD-HN 350		
	ROTA 2B 315				
	ROTA NCO 400				
ROTA 2B 400					

- 1
- 2
- 3
- 4
- 5
- 6
- 7

Dystrybucja: [unihurt.pl](http://unihurt.pl)  
  
 Zamówienia: [info@unihurt.pl](mailto:info@unihurt.pl) **MG**



- 1
- 2
- 3
- 4
- 5
- 6
- 7
- C

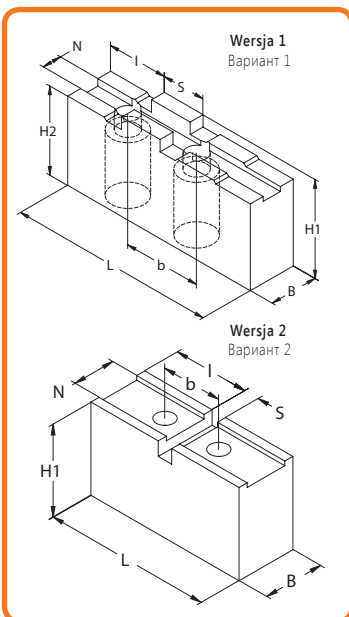

**SZCZĘKI GÓRNE MIĘKKIE**  
 КУЛАЧКИ МЯГКИЕ НАКЛАДНЫЕ (СЫРЫЕ)

**Z WPUSTEM I ROWKIEM**  
 С СИСТЕМОЙ ПАЗ-ШПОНКА

Nr produktu Код продукта	Typ szczęk Тип кулачков	Wersja Вариант	N	S	B	H <sub>1</sub>	H <sub>2</sub>	L	b	I	kg / kpl.
											кг / кпл.
398525436700	SGM Z5PS 140-01	1	8	18	20	40	36	69	32	25	0,9
398525438200	SGM Z5PS 160-01 F	1	8	18	25	42	38	85	32	25	1,5
398525443000	SGM Z5PS 200-01 F	1	10	20	22	47	43	105	40	34	2,0
398525449700	SGM Z5PS 250-01 F	1	12	20	32	55	50	125	40	36	3,7
398525458600	SGM Z5PS 315-01 F	1	12	26	37	62	56	145	54	45	6,1
398525478000	SGM Z6PS 125-01	2	14	5	20	30	-	55	20	25	0,6
398525468800	SGM Z5PS 400-01 F	1	18	30	45	82	75	180	60	50	13,6
398525475100	SGM Z5PS 500-01	1	18	40	60	90	82	220	76	58	23,3
398525476400	SGM Z5PS 630-01	1	24	40	65	118	110	260	82	70	39,1
398525477700	SGM Z5PS 1000-01	1	24	40	76	150	142	350	82	70	82,5

Ø 140 - 1000 mm

Dystrybucja: unihurt.pl  
 Zamówienia: info@unihurt.pl



Zamówienia: info@unihurt.pl



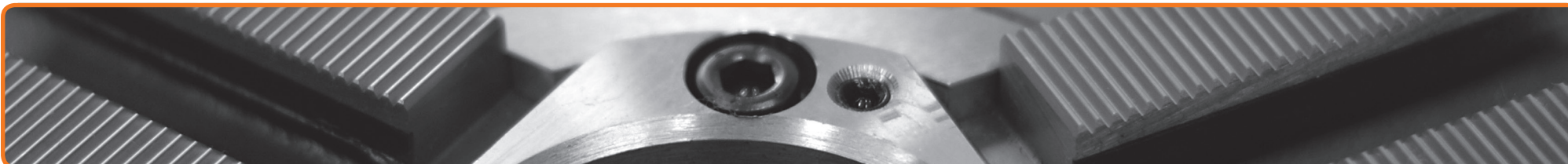

	SCHUNK	FORKARDT	RÖHM	SMW-AUTOBLOK	BERG
Ø 140 - 1000 mm			DURO-NC 140-168	KNCS 140; KNCS-N 140	
	ROTA-G 160; ROTA NCW 185; ROTA-S 160; ROTA-S plus 160; ROTA THW 165; ROTA NCR 200; ROTA THW plus 165-185; THW 165	F 160; F+ 160; FNC 175; KTNC 160; KTNCV 160-175	DURO 160; DURO-NC 160-175; DURO NCE 160; DURO-NCE 175; DURO-NCES 175	HG 160; HG-F 160; HG-N 160; KNCS 160-175; KNCS-N 170; KNSP 160; RMG 160	KHNC 160; KHNC 185
	ROTA-G 200; ROTA NCW 225; ROTA NCWF 210; ROTA-S 200; ROTA-S plus 200; ROTA THW 210; ROTA THW plus 215; ROTA THWB 210; THW 210 R/F; ROTA THW vario 215	F 200; F+ 200; FNC 200; KTNC 200; KTNCV 200	DURO 200; DURO-NC 200-225; DURO-NCE 200; DURO-NCES 200	HG 200; HG-F 210; HG-N 210; KNCS 200-210; KNCS-N 210-225; KNCS-NB 210; KNSP 200; RMG 200	KHNC 200
	ROTA-G 250-315; ROTA NCW 265-315; ROTA NCWF 250-315; ROTA-S 250; ROTA-S plus 250; ROTA THW 250-315; ROTA THW plus 260-315; ROTA THWB 265; THW 250-265-R/F; THW 315-R	F 250; F+ 250; FNC 250-315; KTNC/KTNCV 250-315; UNC 250-315	DURO 250; DURO-NC 250; DURO-NCE 250-315; DURO-NCES 250; DURO-NCES 315	HG 250-315; HG-F 260; HG-N 260-315; KNCS 250-315; KNCS-N 260-275-315-340; KNCS-NB 260; KNCS-NB 315; RMG 250	KHNC 250; KHNC 315
	ROTA-G 400; ROTA-S 315; ROTA-S plus 315; ROTA THW 400; ROTA THWB 315; THW 315-F; THW 400-R/F	F 315; F+ 315; FNC 400; KTNC 360-400; KTNCV 400; UNC 400	DURO 315; DURO-NC 315; DURO-NCE 400; DURO-NCES 315; DURO-NCES 400	HG-F 315; HG 400; HG-N 400; KNCS/KNCS-N 400; KNCS-NB 400; RMG 315	KHNC 400
		F 125; F+ 125	DURO 125	RMG 125	
	ROTA-G 500; ROTA-S 400-500; ROTA-S plus 400-500; ROTA THW 500-630-800; ROTA THWB 400-500; THW 500-R/F; THW 630-R	F 400-500 L; F+ 400-500 L; FNC 500-630; KTNC/KTNCV 500-630; UNC 500	DURO 400-500; DURO-NC 400-500; DURO-NCE 500; DURO-NCES 400	HG 500-630; HG-N 500-630; HG-F 400-500; KNCS 500-630; KNCS-N 500-630; KNCS-NB 500-630-800	KHNC 500
		F 500			
	ROTA-G 630; ROTA-S 630-800; ROTA-S plus 630-800	F 630; F+ 630	DURO 630; DURO-NC 630	HG-F 630	
	ROTA-S 1000; ROTA-S plus 1000				





- 1
- 2
- 3
- 4
- 5
- 6
- 7
- C

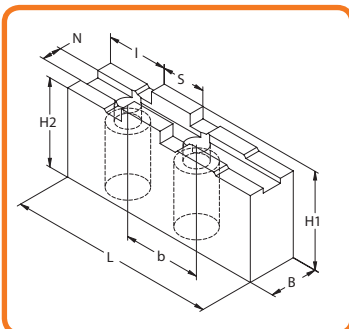

**SZCZĘKI GÓRNE MIĘKIE**  
 КУЛАЧКИ МЯГКИЕ НАКЛАДНЫЕ (СЫРЫЕ)

**Z WPUSTEM I ROWKIEM**  
 С СИСТЕМОЙ ПАЗ-ШПОНКА

Nr produktu	Typ szczęk	N	S	B	H <sub>1</sub>	H <sub>2</sub>	L	b	I	kg / kpl.
										Код продукта
398525437000	SGM Z5PS 140-02	8	18	30	45	41	63	32	19	1,5
398525439500	SGM Z5PS 160-02	8	18	30	55,5	51,5	85	32	19	2,7
398525440200	SGM Z5PS 160-03	8	18	35	40	36	63	32	19	1,6
398525441500	SGM Z5PS 160-04	8	18	40	60	56	70	32	19	3,3
398525442800	SGM Z5PS 160-05	8	18	40	80	76	85	32	19	5,4
398525444300	SGM Z5PS 200-02	10	20	30	55,5	51,5	100	40	23	3,2
398525445600	SGM Z5PS 200-03	10	20	22	55,5	51,5	100	40	23	2,2
398525446900	SGM Z5PS 200-04	10	20	40	40	36	70	40	23	2,1
398525447100	SGM Z5PS 200-05	10	20	40	60	56	85	40	23	4,0
398525448400	SGM Z5PS 200-06	10	20	40	80	76	95	40	23	6,1
398525450400	SGM Z5PS 250-02	12	20	40	60	55	90	40	26	3,9
398525451700	SGM Z5PS 250-03	12	20	40	60	55	125	40	26	5,6
398525452000	SGM Z5PS 250-04	12	20	40	80	75	125	40	26	7,7
398525453200	SGM Z5PS 250-05	12	20	40	100	95	125	40	26	9,7
398525454500	SGM Z5PS 250-06	12	20	40	120	115	125	40	26	11,7
398525455800	SGM Z5PS 250-07	12	20	60	60	55	90	40	26	6,2
398525456000	SGM Z5PS 250-08	12	20	80	60	55	90	40	26	8,6
398525457300	SGM Z5PS 250-09	12	20	80	100	95	125	40	26	20,8
398525459900	SGM Z5PS 315-02	12	26	40	60	54	110	54	30	4,9
398525460600	SGM Z5PS 315-03	12	26	40	60	54	145	54	30	6,6
398525461900	SGM Z5PS 315-04	12	26	40	100	94	145	54	30	11,4
398525462100	SGM Z5PS 315-05	12	26	40	120	114	145	54	30	13,8
398525463400	SGM Z5PS 315-06	12	26	40	150	144	145	54	30	17,5
398525464700	SGM Z5PS 315-07	12	26	50	80	74	145	54	30	11,5
398525465000	SGM Z5PS 315-08	12	26	60	60	54	110	54	30	7,7
398525466200	SGM Z5PS 315-09	12	26	80	60	54	110	54	30	10,5
398525467500	SGM Z5PS 315-10	12	26	80	80	74	110	54	30	14,4
398525469000	SGM Z5PS 400-02	18	30	60	80	73	130	60	35	11,7
398525470800	SGM Z5PS 400-03	18	30	60	100	93	155	60	35	18,0
398525471000	SGM Z5PS 400-04	18	30	60	120	113	155	60	35	21,9
398525472300	SGM Z5PS 400-05	18	30	80	80	73	130	60	35	16,2
398525473600	SGM Z5PS 400-06	18	30	60	180	173	160	60	35	34,6
398525474900	SGM Z5PS 400-07	18	30	96	115	108	115	60	35	25,6

Ø 140 - 400 mm

Dystrybucja: unihurt.pl Zamówienia: info@unihurt.pl



Zamówienia: info@unihurt.pl

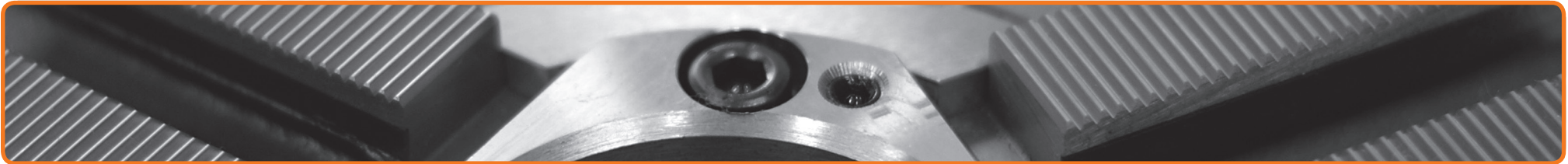

	SCHUNK	FORKARDT	RÖHM	SMW-AUTOBLOK	BERG
Ø 140 - 400 mm	ROTA-G 160; ROTA NCW 185; ROTA-S 160; ROTA-S plus 160; ROTA THW 165; ROTA THW plus 165-185; THW 165; ROTA NCR 200	F 160; F+ 160; FNC 175; KTNC 160; KTNCV 160-175	DURO-NC 140-168  DURO 160; DURO-NC 160-175; DURO-NCE 160-175; DURO-NCES 175	KNCS 140; KNCS-N 140  HG 160; HG-F 160; HG-N 160; KNCS 160-175; KNCS-N 170; KNSP 160; RMG 160	KHNC 160; KHNC 185
	ROTA-G 200; ROTA NCW 225; ROTA NCWF 210; ROTA-S 200; ROTA-S plus 200; ROTA THW 210; ROTA THW plus 215; ROTA THWB 210; THW 210 R/F; ROTA THW vario 215	F 200; F+ 200; FNC 200; KTNC 200; KTNCV 200	DURO 200; DURO-NC 200-225; DURO-NCE 200; DURO-NCES 200	HG 200; HG-F 210; HG-N 210; KNCS 200-210; KNCS-N 210-225; KNCS-NB 210; KNSP 200; RMG 200	KHNC 200
	ROTA-G 250-315; ROTA NCW 265-315; ROTA NCWF 250-315; ROTA-S 250; ROTA-S plus 250; ROTA THW 250-315; ROTA THW plus 260-315; ROTA THWB 265; THW 250-265-R/F; THW 315-R	F 250; F+ 250; FNC 250-315; KTNC/KTNCV 250-315; UNC 250-315	DURO 250; DURO-NC 250; DURO-NCE 250-315; DURO-NCES 250; DURO-NCES 315	HG 250-315; HG-F 260; HG-N 260-315; KNCS 250-315; KNCS-N 260-275-315-340; KNCS-NB 260; RMG 250	KHNC 250; KHNC 315
	ROTA-G 400; ROTA-S 315; ROTA-S plus 315; ROTA THW 400; ROTA THWB 315; THW 315-F; THW 400-R/F	F 315; F+ 315; FNC 400; KTNC 360-400; KTNCV 400; UNC 400	DURO 315; DURO-NC 315; DURO-NCE 400; DURO-NCES 315; DURO-NCES 400	HG-F 315; HG 400; HG-N 400; KNCS/KNCS-N 400; RMG 315	KHNC 400
	ROTA-G 500; ROTA-S 400-500; ROTA-S plus 400-500; ROTA THW 500-630-800; ROTA THWB 400-500; THW 500-R/F; THW 630-R	F 400-500 L; F+ 400-500 L; FNC 500-630; KTNC/KTNCV 500-630; UNC 500	DURO 400-500; DURO-NC 400-500; DURO-NCE 500; DURO-NCES 400	HG 500-630; HG-N 500-630; HG-F 400-500; KNCS 500-630; KNCS-N 500-630	



- 1
- 2
- 3
- 4
- 5
- 6
- 7
- C

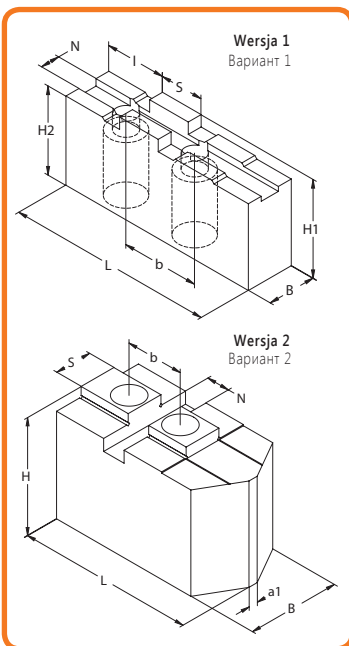

**SZCZĘKI GÓRNE MIĘKKIE**  
 КУЛАЧКИ МЯГКИЕ НАКЛАДНЫЕ (СЫРЫЕ)

**Z WPUSTEM I ROWKIEM**  
 С СИСТЕМОЙ ПАЗ-ШПОНКА

Nr produktu	Typ szczęk	Wersja	N	S	B	H	L	a <sub>1</sub>	b	Śruby	kg / kpl.
Код продукта	Тип кулачков	Вариант								Винты	кг / кпл.
398525480000	SGM Z1VA 110-20	2	8	8	22	47	55,3	1	17	M 8	0,3

Ø 110 - 1000 mm	Nr produktu	Typ szczęk	Wersja	N	S	B	H <sub>1</sub>	H <sub>2</sub>	L	b	I	kg / kpl.
	Код продукта	Тип кулачков	Вариант									кг / кпл.
	398525482500	SGM Z5PA 160-01	1	8	18	25	50	46	85	32	25	0,7
	398525483800	SGM Z5PA 200-01	1	10	20	25	50	46	105	40	35	0,8
	398525484000	SGM Z5PA 250-01	1	12	20	40	60	55	125	40	35	1,9
	398525485300	SGM Z5PA 315-01	1	12	26	40	60	54	145	54	45	2,3
	398525486600	SGM Z5PA 400-01	1	18	30	50	80	73	180	60	50	4,7
	398525487900	SGM Z5PA 630-01	1	24	40	65	118	110	260	82	70	13,6
	398525488100	SGM Z5PA 1000-01	1	24	40	80	155	147	350	82	70	31,2

Dystrybucja: unihurt.pl  
 Zamówienia: info@unihurt.pl



Zamówienia: info@unihurt.pl

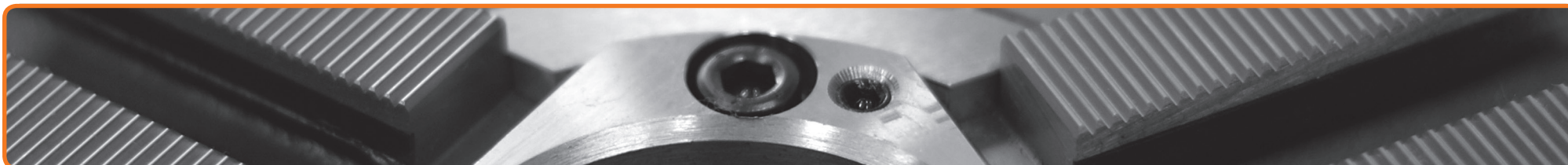

	SCHUNK	FORKARDT	RÖHM	SMW-AUTOBLOK	BERG
	TH 110-25.5		KFD 110; KFD-HS 110		
Ø 110 - 1000 mm	ROTA-G 160; ROTA NCW 185; ROTA-S 160; ROTA-S plus 160; ROTA THW 165; ROTA NCR 200; ROTA THW plus 165-185; THW 165	F 160; F+ 160; FNC 175; KTNC 160; KTNCV 160-175	DURO 160; DURO-NC 160-175; DURO-NCE 160-175; DURO-NCES 175	HG 160; HG-F 160; HG-N 160; KNCS 160-175; KNCS-N 170; KNSP 160; RMG 160	KHNC 160; KHNC 185
	ROTA-G 200; ROTA NCW 225; ROTA NCWF 210; ROTA-S 200; ROTA-S plus 200; ROTA THW 210; ROTA THW plus 215; ROTA THWB 210; THW 210 R/F; ROTA THW vario 215	F 200; F+ 200; FNC 200; KTNC 200; KTNCV 200	DURO 200; DURO-NC 200-225; DURO-NCE 200; DURO-NCES 200	HG 200; HG-F 210; HG-N 210; KNCS 200-210; KNCS-N 210-225; KNCS-NB 210; KNSP 200; RMG 200	KHNC 200
	ROTA-G 250-315; ROTA NCW 265-315; ROTA NCWF 250-315; ROTA-S 250; ROTA-S plus 250; ROTA THW 250-315; ROTA THW plus 260-315; ROTA THWB 265; THW 250-265-R/F; THW 315-R	F 250; F+ 250; FNC 250-315; KTNC/KTNCV 250-315; UNC 250-315	DURO 250; DURO-NC 250; DURO-NCE 250-315; DURO-NCES 250; DURO-NCES 315	HG 250-315; HG-F 260; HG-N 260-315; KNCS 250-315; KNCS-N 260-275-315-340; KNCS-NB 260; KNCS-NB 315; RMG 250	KHNC 250; KHNC 315
	ROTA-G 400; ROTA-S 315; ROTA-S plus 315; ROTA THW 400; ROTA THWB 315; THW 315-F; THW 400-R/F	F 315; F+ 315; FNC 400; KTNC 360-400; KTNCV 400; UNC 400	DURO 315; DURO-NC 315; DURO-NCE 400; DURO-NCES 315; DURO-NCES 400	HG-F 315; HG 400; HG-N 400; KNCS/KNCS-N 400; KNCS-NB 400; RMG 315	KHNC 400
	ROTA-G 500; ROTA-S 400-500; ROTA-S plus 400-500; ROTA THW 500-630-800; ROTA THWB 400-500; THW 500-R/F; THW 630-R	F 400-500 L; F+ 400-500 L; FNC 500-630; KTNC/KTNCV 500-630; UNC 500	DURO 400-500; DURO-NC 400-500; DURO-NCE 500; DURO-NCES 400	HG 500-630; HG-N 500-630; HG-F 400-500; KNCS 500-630; KNCS-N 500-630; KNCS-NB 500-630-800	KHNC 500
	ROTA-G 630; ROTA-S 630-800; ROTA-S plus 630-800	F 630; F+ 630	DURO 630; DURO-NC 630	HG-F 630	
	ROTA-S 1000; ROTA-S plus 1000				

1  
2  
3  
4  
5  
6  
7  
Dystrybucja: [unihurt.pl](mailto:unihurt.pl)  
  
 Zamówienia: [info@unihurt.pl](mailto:info@unihurt.pl) **SGM**

- 1
- 2
- 3
- 4
- 5
- 6
- 7
- C

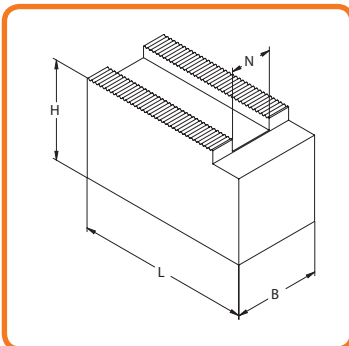

**SZCZĘKI GÓRNE MIĘKIE BEZ OTWORÓW**  
 КУЛАЧКИ МЯГКИЕ НЕОБРАБОТАННЫЕ НАКЛАДНЫЕ

**METRYCZNA WIELKOŚĆ KĄTA ZĄBKÓW 1,5 mm x 60°**  
 МЕТРИЧЕСКОЕ ЗУБЧАТОЕ СОЕДИНЕНИЕ 1,5 мм x 60°



Nr produktu	Typ szczęk	N	B	H	L	kg / kpl.
Код продукта	Тип кулачков					кг / кпл.
<b>z rowkiem 10 mm • с пазом 10 мм</b>						
398525102800	SGM MPS 110-10-01R	10	22	47	55	1,3
<b>z rowkiem 12 mm • с пазом 12 мм</b>						
398525104300	SGM MPS 160-12-01R	12	35	60	80	3,8
<b>z rowkiem 14 mm • с пазом 14 мм</b>						
398525107100	SGM MPS 200-14-02R	14	40	40	70	2,5
398525108400	SGM MPS 200-14-03R	14	40	40	95	3,3
398525109700	SGM MPS 200-14-04R	14	40	60	70	3,8
398525110400	SGM MPS 200-14-05R	14	40	60	95	5,1
398525106900	SGM MPS 200-14-01R	14	40	80	95	6,9
398525111700	SGM MPS 200-14-06R	14	40	100	95	8,7
398525112000	SGM MPS 200-14-07R	14	60	60	70	5,7
398525113200	SGM MPS 200-14-08R	14	80	60	70	7,6
<b>z rowkiem 16 mm • с пазом 16 мм</b>						
398525117300	SGM MPS 250-16-02R	16	40	60	90	4,8
398525118600	SGM MPS 250-16-03R	16	40	60	110	5,9
398525116000	SGM MPS 250-16-01R	16	40	80	120	8,7
398525119900	SGM MPS 250-16-04R	16	40	100	110	10,0
398525120600	SGM MPS 250-16-05R	16	50	120	110	15,2
398525121900	SGM MPS 250-16-06R	16	60	60	95	7,7
398525122100	SGM MPS 250-16-07R	16	60	90	95	11,7
398525123400	SGM MPS 250-16-08R	16	80	60	95	10,4
<b>z rowkiem 21 mm • с пазом 21 мм</b>						
398525125000	SGM MPS 315-21-01R	21	50	60	130	8,8
398525126200	SGM MPS 315-21-02R	21	50	80	130	11,8
398525127500	SGM MPS 315-21-03R	21	50	120	130	17,9
398525128800	SGM MPS 315-21-04R	21	60	150	130	27,0
398525129000	SGM MPS 315-21-05R	21	80	80	130	19,1

1,5 mm x 60°

Dystrybucja: unihurt.pl  
 Zamówienia: info@unihurt.pl

SGM MSR

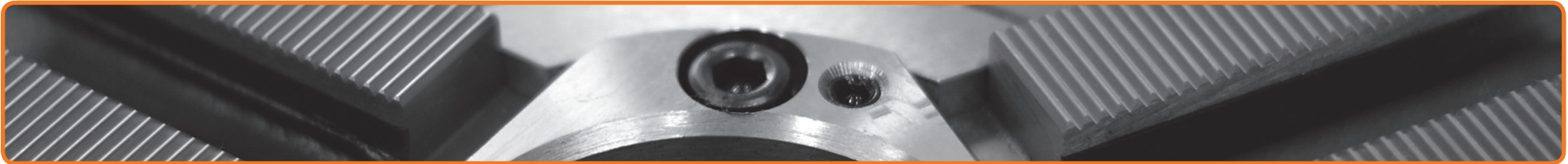

SCHUNK	KITAGAWA	RÖHM	SMW-AUTOBLOK	HOWA
<b>z rowkiem 10 mm • с пазом 10 мм</b>				
				HO 1 MA 4; HO 24 M 5; HO 1 MA 5
<b>z rowkiem 12 mm • с пазом 12 мм</b>				
ROTA NCD 165-185; ROTA NC/NCF 165; ROTA NCK 165; HSL 165; ROTA NCK plus 165; ROTA NC/NCF plus 185	AS 165; B 06; BB 06; B 106; B 160; B 206; BB 206; B 7; B 07; HJA 5-6; HO 6; HOB 6; HOH 06; HOH 106; HOH 160; HOH 206; HOS 6; N 06; N 160	KFD-HE 170	AL-M 125-165; AN-M 125-165; BB-M 140-175; BH-M 130-165; BH-M FC 165; HB-M 130-165; HFKN-M 165; PB-M/PBI-M 130-165	HO 7 MA 6; HO 15 M 6; HO 22 M 6; HO 24 M 6; HO 27 M 6; HO 37 M 6; HO 47 M 6
<b>z rowkiem 14 mm • с пазом 14 мм</b>				
ROTA NCD 210; ROTA NC/NCF 210; ROTA NCK 210; HSL 210; ROTA NCK plus 210; ROTA NC plus 215; ROTA NCF plus 215	AS 210; B 08; B 108; B 200; B 208; BB 08; BB 208; HJA 6-8; HO 8; HOB 8; HOH 8; HOH 108; HOH 200; HOH 208; HOS 8; N 08; N 200	KFD-HE 210	AL-M 210; AN-M 210; BB-M 210; BH-M 210; BH-M FC 210; HB-M 210; HFKN-M 210; PB-M/PBI-M 210	HO 7 MA 8; HO 15 M 8; HO 23 M 8
<b>z rowkiem 16 mm • с пазом 16 мм</b>				
ROTA NCD 250; ROTA NC/NCF 250; ROTA NCK 250; HSL 250; ROTA NCK plus 250; ROTA NC plus 260; ROTA NCF plus 260	AS 250; B 10; B 110; B 210; B 250; BB 10; BB 210; HJA 6-10; HJA 8-10; HO 10; HOB 10; HOH 10; HOH 110; HOH 210; HOH 250; HOS 10; N 10; N 250	KFD-HE 254	AL-M 250; AN-M 250; BB-M 250; BH-M 250; BH-M FC 250; HBM 250; HFKN-M 260; PB-M/PBI-M 250	HO 22 M 8; HO 24 M 8; HO 27 M 8; HO 37 M 8; HO 47 M 8; HO 7 MA 10; HO 15 M 10; HO 23 M 10
<b>z rowkiem 21 mm • с пазом 21 мм</b>				
ROTA NCD 315; ROTA NCK 315; HSL 315; ROTA NCK plus 315; ROTA NC plus 315; ROTA NCF plus 315	B 112; B 212; BB 212; HOH 112; HOH 212	KFD-HE 315	AL-M 315; AN-M 315; BB-M 305-315; BH-M 315; BH-M FC 315-400; GH-M 400; HB-M 305-315; HFKN-M 315; PB-M/PBI-M 315; RC-M 305-315-400	HO 27 M 12; HO 37 M 12; HO 47 M 12

1,5 mm x 60°

- 1
- 2
- 3
- 4
- 5
- 6
- 7

Dystrybucja: unihurt.pl  
Zamówienia: info@unihurt.pl | I GMS



**SZCZĘKI GÓRNE MIĘKIE BEZ OTWORÓW**  
 КУЛАЧКИ МЯГКИЕ НЕОБРАБОТАННЫЕ НАКЛАДНЫЕ

**CALOWA WIELKOŚĆ KĄTA ZĄBKÓW 1/16" x 90° LUB 3/32" x 90°**  
 ДЮЙМОВОЕ ЗУБЧАТОЕ СОЕДИНЕНИЕ 1/16" x 90° ИЛИ 3/32" x 90°

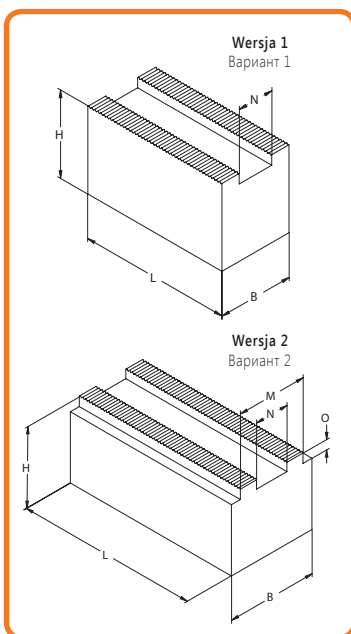

Nr produktu Код продукта	Typ szczęk Тип кулачков	Wersja Вариант	M	N	O	B	H	L	kg / kpl.	
									кг / кпл.	
<b>z rowkiem 17 mm • с пазом 17 мм</b>										
1/16" x 90°	398525217400	SGM CPS 160-17-01R	1	-	17	-	40	40	70	2,5
	398525218700	SGM CPS 160-17-02R	1	-	17	-	40	40	90	3,2
	398525219000	SGM CPS 160-17-03R	1	-	17	-	40	40	105	3,7
	398525220700	SGM CPS 160-17-04R	1	-	17	-	40	60	70	3,8
	398525221000	SGM CPS 160-17-05R	1	-	17	-	40	60	90	4,8
	398525222200	SGM CPS 160-17-06R	1	-	17	-	40	60	105	5,7
	398525223500	SGM CPS 160-17-07R	1	-	17	-	40	60	120	6,5
	398525227600	SGM CPS 160-17-11R	1	-	17	-	40	80	90	6,5
	398525224800	SGM CPS 160-17-08R	1	-	17	-	40	100	90	8,2
	398525225000	SGM CPS 160-17-09R	1	-	17	-	40	120	90	9,9
	398525226300	SGM CPS 160-17-10R	2	40	17	5	50	80	90	8,2
	398525228900	SGM CPS 160-17-12R	2	40	17	5	60	60	70	5,7
	398525229100	SGM CPS 160-17-13R	2	40	17	5	60	60	90	7,3
	398525230900	SGM CPS 160-17-14R	2	40	17	5	80	60	90	9,8
<b>z rowkiem 21 mm • с пазом 21 мм</b>										
1/16" x 90°	398525233700	SGM CPS 250-21-01R	1	-	21	-	50	60	90	6,1
	398525234000	SGM CPS 250-21-02R	1	-	21	-	50	60	105	7,1
	398525238000	SGM CPS 250-21-06R	1	-	21	-	50	80	120	10,9
	398525239300	SGM CPS 250-21-07R	1	-	21	-	50	80	150	13,6
	398525235200	SGM CPS 250-21-03R	1	-	21	-	50	100	120	13,7
	398525236500	SGM CPS 250-21-04R	1	-	21	-	50	120	120	16,5
	398525237800	SGM CPS 250-21-05R	1	-	21	-	50	150	120	20,7
	398525240000	SGM CPS 250-21-08R	2	50	21	5	60	60	90	7,3
	398525241300	SGM CPS 250-21-09R	2	50	21	5	60	60	105	8,5
	398525242600	SGM CPS 250-21-10R	2	50	21	5	60	80	90	9,8
	398525243900	SGM CPS 250-21-11R	2	50	21	5	60	80	105	11,5
	398525244100	SGM CPS 250-21-12R	2	50	21	5	60	80	120	13,1
	398525245400	SGM CPS 250-21-13R	2	50	21	5	80	60	90	9,8
	398525246700	SGM CPS 250-21-14R	2	50	21	5	80	80	120	17,6
<b>z rowkiem 25,5 mm • с пазом 25,5 мм</b>										
3/32" x 90°	398525261700	SGM CPS 400-25,5-01R	1	-	25,5	-	60	60	140	11,3
	398525262000	SGM CPS 400-25,5-02R	1	-	25,5	-	60	80	140	15,2
	398525263200	SGM CPS 400-25,5-03R	1	-	25,5	-	60	100	140	19,1
	398525264500	SGM CPS 400-25,5-04R	1	-	25,5	-	60	100	155	21,2
	398525265800	SGM CPS 400-25,5-05R	1	-	25,5	-	60	100	195	26,7
	398525266000	SGM CPS 400-25,5-06R	1	-	25,5	-	60	120	155	25,6
	398525267300	SGM CPS 400-25,5-07R	1	-	25,5	-	60	160	155	34,3
	398525268600	SGM CPS 400-25,5-08R	1	-	25,5	-	60	200	155	43,0
	398525269900	SGM CPS 400-25,5-09R	2	60	25,5	5	80	80	155	22,6
	398525270600	SGM CPS 400-25,5-10R	2	60	25,5	5	100	100	155	35,6

Dystrybucja: unihurt.pl  
 Zamówienia: info@unihurt.pl



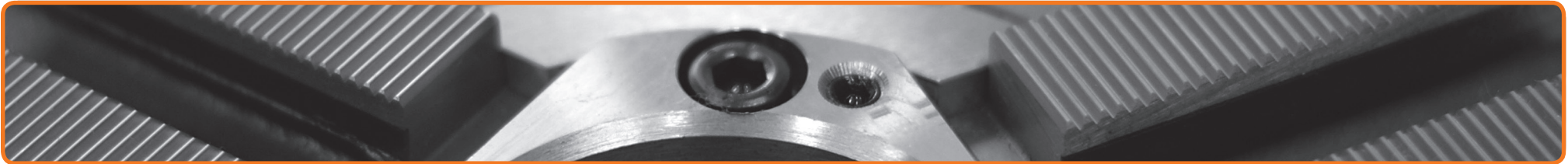

	SCHUNK	FORKARDT	RÖHM	SMW-AUTOBLOK	BERG
	<b>z rowkiem 17 mm • с пазом 17 мм</b>				
1/16" x 90°	HSG 200-250; HSL 165-210; ROTA 2B 160; ROTA NC 165-210; ROTA NCD 185-210; ROTA NCF 165-210; ROTA NCO 165-210; ROTA TP 200; TH/THF 165-210; TP 200; ROTA NCK plus 210-250; ROTA NC plus 215; ROTA NCF plus 215	KGH/KGHF 160-175-200; KL/KS 160-200; KSF 175-200; KSH/KSPS 160-200; KT/KTG/KTN 160-200; KTH 160-175-200; NH/NHF 160-175-200; QLC 160-175-200; QLK 160-175-200; QLC-KS/QLK-KS 200-250; KLNC/KP 200; KS/KSHF 200-250; KTGf 200; KL/KS 250 (Monforts); NHF 250-290 (Index); UVE 160-200-250	KFD 160-200; KFD-AF 160-200; KFD-HE 210; KFD-HF 160-200; KFD-HS 200-250; KFH 160-200; KFH-F 160-200; KFH-G 160-200; KFH-NC 160-200; LVE 160-200; SPD 160-215; SPO 160-215	AL-D/AN-D 210; BB-D 210; BH-D/BHD-FC 210; CD 200; GHD-FC/GHDN 210; HB-D 210; HDB 220; HDN 200-220-250S; HFK/HFKS 160-200; HFKN-D 210; HYDN-S 210-226; KFMF 160-200; KfV 160-200; LP 205; PB-D/PBI-D 210; RCD 210; KDV/KDVG 160-200-250; ODL/ODN 200-220; SP/STP/STWP 200	HES 160; HESF 160; KF 160; HES 200; HESF 200; KF 200; KHFF 200
	<b>z rowkiem 21 mm • с пазом 21 мм</b>				
1/16" x 90°	ROTA 2B 200; HSG 315; HSL 250-315; ROTA NC 250-315; ROTA NCD 250-315; ROTA NCF 250-315; ROTA NCO 260-315; ROTA TP 250-315; TH/THF 250-315; TP 250-315; ROTA NCK plus 315; ROTA NC plus 260-315; ROTA NCF plus 260-315; ROTA NCR 500-630-800	2BLE 200; 2 BLE 250 (Monforts); 2BLN 200; KG 250-315; KL 250; KLNC/KP 250-315; KS 315-400; KSH/KSHF 250-400; KSPS 250-300; KT/KTG/KTGF/KTN 250-315; NH/NHF 250-315; NHF 257-290; NHF 400 (Index); QLC/QLK 250-315; QLC-KS/QLK-KS 315-400; UVE 315	KFD 250-315; KFD-AF 250-315; KFD-HE 254-315; KFD-HF 250-315; KFD-HS 315; KFH 250-315; KFH-F 250-315; KFH-G 250-315; KFH-NC 250-315; KFL 315-400; LVE 250-305-315; SPD 300; SPO 300	AL-D/AN-D 250-315; BB-D 250-315; BH-D 250-315; BHD-FC 250-400; CD 250-315; GHD-FC/GHDN 250-305-315-400; GHD 400; HB-D 250-315; HDB 300; HDL/HDN 250-315-400; HFK/HFKS 250-315; HFKN-D 260-315; HYDN-S 250-315; KDV/KDVG 315-400; KFMF 250-315; KfV 250-315; LP 250; ODL/ODN 250-315-400; PB-D/PBI-D 250-315; RCD 250-305-400; SP 250-280-305-350; STP 250-280-315	HES 250; HESF 250; KF 250; KHFF 250; HES 315; HESF 315; KF 315; KHFF 315
	<b>z rowkiem 25,5 mm • с пазом 25,5 мм</b>				
3/32" x 90°	HSG 400-500; HSL 400; ROTA NC 400-500; ROTA NCD 400-500; ROTA NCF 400-500; ROTA NCO 400-500; ROTA NCR 1000; TH/THF 400-500; ROTA EP 500; ROTA NC 630-800	KG 400-500; KL/KLNC 400-500; KP 400-500; KS 500-630; KSH 500; KSHF 630; KS-L 630; KSPS 400; KT/KTGf 400-630; KTG/KTN 400-500; NH/NHF 400-630; QLC/QLK 400; UVE 400-800	KFD 400-500-630-800; KFD-HE 400; KFD-HF 400-500-630; KFD-HS 400-500; KFH 400-500; KFH-F 400-500; KFH-G 400-500; KFH-NC 400-500; KFL 500-600; LVE 400-500-630-800	AL-D/AND 400; BB-N 400-460-500 ab Bj. 98; BH-D 400-450; BHD-FC 500-630; GHD 500-610-640-800; HFK/HFKS 400-500; HFKN-D 400-500; İLD/İND 500-630-800; KDV/KDVG 500; KfV 400-500-630-800; RCD 500-630; BH-D 630-800	HES 400; HESF 400; KF 400; KHFF 400; HES 500; HESF 500; KF 500; HES 630; HESF 630; KF 630

- 1
- 2
- 3
- 4
- 5
- 6

7

Dystrybucja: [unihurt.pl](http://unihurt.pl)



Zamówienia: [info@unihurt.pl](mailto:info@unihurt.pl) | GSM





- 1
- 2
- 3
- 4
- 5
- 6
- 7
- C

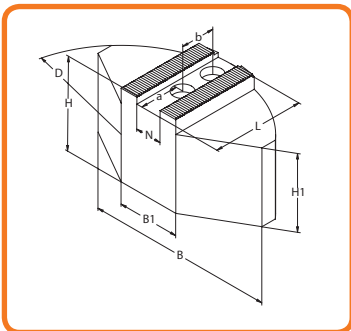

**SZCZĘKI MIĘKKIE Z PEŁNYM CHWYTEM**  
 КУЛАЧКИ МЯГКИЕ СЕГМЕНТНЫЕ НАКЛАДНЫЕ

**METRYCZNA WIELKOŚĆ KĄTA ZĄBKÓW 1,5 mm x 60°**  
 МЕТРИЧЕСКОЕ ЗУБЧАТОЕ СОЕДИНЕНИЕ 1,5 мм x 60°



Nr produktu	Typ szczęk	Materiał	N	B	H	L	Ø D	B <sub>1</sub>	H <sub>1</sub>	a + b	Śruby	kg / kpl.
											Винты	кг / кпл.
398525530100	SGM MMS 160-12-01	Stal / Сталь	12	120	50	60	160	50	40	25 + 20	M 10	5,1
398525531400	SGM MMA 160-12-01	Alu. / Алю.	12	120	58	59,5	165	40	48	25 + 20	M10	2,0
398525532700	SGM MMS 200-14-01	Stal / Сталь	14	140	60	70	200	70	50	30 + 25	M 12	9,0
398525533000	SGM MMS 200-14-02	Stal / Сталь	14	140	80	70	200	70	70	30 + 25	M12	12,3
398525534200	SGM MMA 200-14-01	Alu. / Алю.	14	140	58	72,5	200	50	48	35 + 25	M 12	2,9
398525535500	SGM MMA 200-14-02	Alu. / Алю.	14	140	80	72,5	200	50	70	35 + 25	M 12	4,2
398525536800	SGM MMS 250-16-01	Stal / Сталь	16	180	60	80	250	100	45	30 + 30	M 12	12,2
398525537000	SGM MMS 250-16-02	Stal / Сталь	16	180	80	80	250	100	70	30 + 30	M 12	18,1
398525538300	SGM MMA 250-16-01	Alu. / Алю.	16	180	58	87,5	250	70	43	40 + 30	M 12	4,3
398525539600	SGM MMA 250-16-02	Alu. / Алю.	16	180	80	87,5	250	70	65	40 + 30	M 12	6,3
398525540300	SGM MMS 315-18-01	Stal / Сталь	18	240	70	110	300	120	55	40 + 30	M 14	26,2
398525541600	SGM MMA 315-18-01	Alu. / Алю.	18	240	78	117	320	80	63	40 + 30	M 14	10,5
398525542900	SGM MMS 315-21-01	Stal / Сталь	21	240	70	110	300	120	55	45 + 30	M 16	25,9
398525543100	SGM MMA 315-21-01	Alu. / Алю.	21	240	78	117	320	80	63	45 + 30	M 16	10,4

**Wkładki teowe** str. 492-501  
 Т-образные вкладки стр.

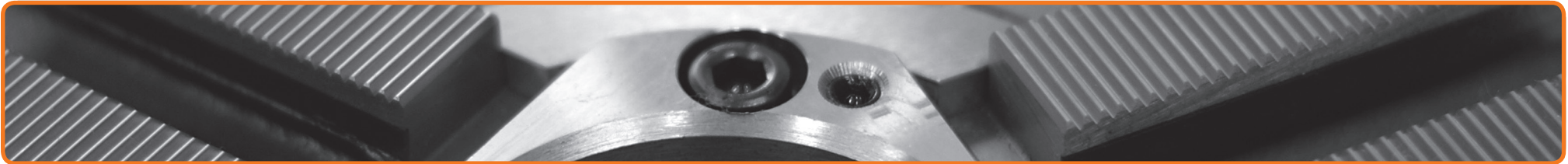

	SCHUNK	KITAGAWA	RÖHM	SMW-AUTOBLOK	HOWA
Ø 160 - 315 mm	ROTA NCD 160-185; ROTA NCK 165; HSL 165; ROTA NC/NCF 165; ROTA NCK plus 165; ROTA NC plus 185; ROTA NCF plus 185	AS 165; B 06; BB 06; B 106; B 160; B 206; BB 206; B7; B 07; HJA 5-6; HO 6; HOB 6; HOH 06; HOH 106; HOH 160; HOH 206; HOS 6; N 06; N 160	KFD-HE 170	AL-M 165; AN-M 165; BB-M 175; BH-M 165; BH-M FC 165; HB-M 165; HFKN-M 165; PB-M/PBI-M 165	HO 7 MA 6; HO 15 M 6; HO 22 M 6; HO 24 M 6; HO 27 M 6; HO 37 M 6; HO 47 M 6
	ROTA NCD 210; ROTA NCK 210; HSL 210; ROTA NC/NCF 210; ROTA NCK plus 210; ROTA NC plus 215; ROTA NCF plus 215	AS 210; B 08; B 108; B 200; B 208; BB 08; BB 208; HJA 6-8; HO 8; HOB 8; HOH 8; HOH 108; HOH 200; HOH 208; HOS 8; N 08; N 200	KFD-HE 210	AL-M 210; AN-M 210; BB-M 210; BH-M 210; BH-M FC 210; HB-M 210; HFKN-M 210; PB-M/PBI-M 210	HO 7 MA 8; HO 15 M 8; HO 23 M 8
	ROTA NCD 250; ROTA NCK 250; HSL 250; ROTA NC/NCF 250; ROTA NCK plus 250; ROTA NC plus 260; ROTA NCF plus 260	AS 250; B 10; B 110; B 210; B 250; BB 10; BB 210; HJA 6-10; HJA 8-10; HO 10; HOB 10; HOH 10; HOH 110; HOH 210; HOH 250; HOS 10; N 10; N 250	KFD-HE 254	AL-M 250; AN-M 250; BB-M 250; BH-M 250; BH-M FC 250; HBM 250; HFKN-M 260; PB-M/PBI-M 250	
		B 12; B 300; HJA 6-12; HJA 8-12; HLA 6-12; HLA 6-15; HLA 8-15; HO 12; HOB 12; HOH 12; HOH 300; HOS 12; N 12; N 300			
	ROTA NCD 315; ROTA NCK 315; HSL 315; ROTA NCK plus 315; ROTA NC plus 315; ROTA NCF plus 315	B 112; B 212; BB 212; HOH 112; HOH 212	KFD-HE 315	AL-M 315; AN-M 315; BB-M 305-315; BH-M 315; BH-M FC 315; HB-M 305-315; HFKN-M 315; PB-M/PBI-M 315; RC-M 305-315	

- 1
- 2
- 3
- 4
- 5
- 6

7

Dystrybucja: [unihurt.pl](http://unihurt.pl)



Zamówienia: [info@unihurt.pl](mailto:info@unihurt.pl) | **SGM**



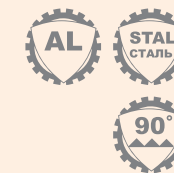

**SZCZĘKI MIĘKIE Z PEŁNYM CHWYTEM**  
КУЛАЧКИ МЯГКИЕ СЕГМЕНТНЫЕ НАКЛАДНЫЕ

**CALOWA WIELKOŚĆ KĄTA ZĄBKÓW 1/16" x 90° LUB 3/32" x 90°**  
ДЮЙМОВОЕ ЗУБЧАТОЕ СОЕДИНЕНИЕ 1/16" x 90° ИЛИ 3/32" x 90°

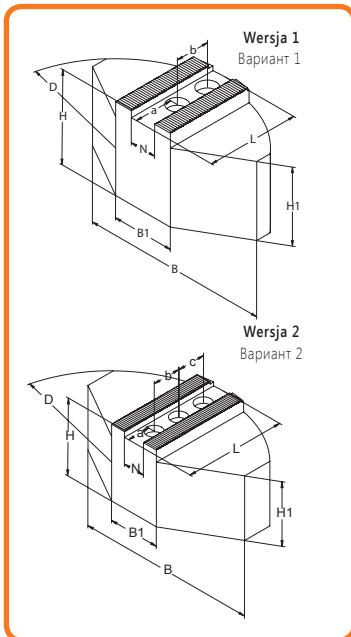

Nr produktu	Typ szczęk	Wersja	Materiał	N	B	H	L	Ø D	B <sub>1</sub>	H <sub>1</sub>	a + b (+c)	Śruby		kg / kpl.
												Winyty	кг / кпл.	
398525550500	SGM CMS 130-10-01	2	Stal / Stal	10	100	40	50	130	35	35	15 + 12 + 12	M 6	2,8	
398525551800	SGM CMA 130-10-01	2	Alu. / Alju.	10	100	48	50	130	35	43	15 + 12 + 12	M 6	1,2	
398525553300	SGM CMS 160-12-01	2	Stal / Stal	12	120	60	60	160	40	50	20 + 15 + 15	M 8	5,8	
398525555900	SGM CMA 160-12-01	2	Alu. / Alju.	12	120	58	59,5	165	40	48	20 + 15 + 15	M 8	1,9	
398525552000	SGM CMS 200-12-01	1	Stal / Stal	12	120	60	60	175	50	50	24 + 21	M 12	6,1	
398525554600	SGM CMA 200-12-01	1	Alu. / Alju.	12	120	58	59,5	165	40	48	24 + 21	M 12	1,9	
398525556100	SGM CMS 160-14-01	1	Stal / Stal	14	120	60	60	160	40	50	25 + 20	M 10	6,0	
398525557400	SGM CMA 160-14-01	1	Alu. / Alju.	14	120	58	59,5	165	40	48	25 + 20	M 10	2,0	
398525558700	SGM CMS 250-16-01	1	Stal / Stal	16	180	60	80	250	80	50	33 + 29	M 16	11,9	
398525559000	SGM CMA 250-16-01	1	Alu. / Alju.	16	180	58	87,5	250	70	48	43 + 29	M 16	4,4	
398525560700	SGM CMS 160-17-01	1	Stal / Stal	17	120	60	60	160	40	50	25 + 22	M 12	5,8	
398525565000	SGM CMA 160-17-01	1	Alu. / Alju.	17	120	58	59,5	165	40	48	22 + 22	M 12	1,9	
398525563500	SGM CMS 200-17-03	1	Stal / Stal	17	140	60	70	200	50	50	36 + 19	M 12	8,3	
398525568900	SGM CMA 200-17-03	1	Alu. / Alju.	17	140	58	72,5	200	50	48	41 + 19	M 12	2,9	
398525561000	SGM CMS 200-17-01	1	Stal / Stal	17	140	60	70	200	64	50	35 + 22	M 12	8,8	
398525562200	SGM CMS 200-17-02	1	Stal / Stal	17	140	75	70	200	64	65	35 + 22	M 12	11,2	
398525566300	SGM CMA 200-17-01	1	Alu. / Alju.	17	140	58	72,5	200	50	48	35 + 22	M 12	2,9	
398525567600	SGM CMA 200-17-02	1	Alu. / Alju.	17	140	75	72,5	200	50	65	35 + 22	M 12	3,9	
398525564800	SGM CMS 250-17-01	1	Stal / Stal	17	180	60	80	250	104	45	45 + 22	M 12	12,3	
398525569100	SGM CMS 250-21-01	1	Stal / Stal	21	180	70	80	250	104	55	30 + 28	M 16	14,3	
398525570900	SGM CMS 250-21-02	1	Stal / Stal	21	180	100	80	250	104	85	30 + 28	M 16	21,6	
398525572400	SGM CMA 250-21-01	1	Alu. / Alju.	21	180	78	87,5	250	70	63	40 + 28	M 16	5,9	
398525573700	SGM CMA 250-21-02	1	Alu. / Alju.	21	180	100	87,5	250	70	85	40 + 28	M 16	7,9	
398525571100	SGM CMS 315-21-01	1	Stal / Stal	21	240	70	110	320	120	55	60 + 28	M 16	26,2	
398525574000	SGM CMA 315-21-01	1	Alu. / Alju.	21	240	78	117	320	80	63	70 + 28	M 16	10,4	
398525575200	SGM CMS 400-25,5-01	1	Stal / Stal	25,5	330	85	155	440	150	55	85 + 35	M 20	53,0	
398525576500	SGM CMA 400-25,5-01	1	Alu. / Alju.	25,5	330	98	160	440	150	68	85 + 35	M 20	23,2	

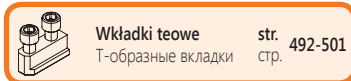

- 1
- 2
- 3
- 4
- 5
- 6
- 7
- C

SGM CMA

SGM CMS

Dystrybucja: unihurt.pl Zamówienia: info@unihurt.pl

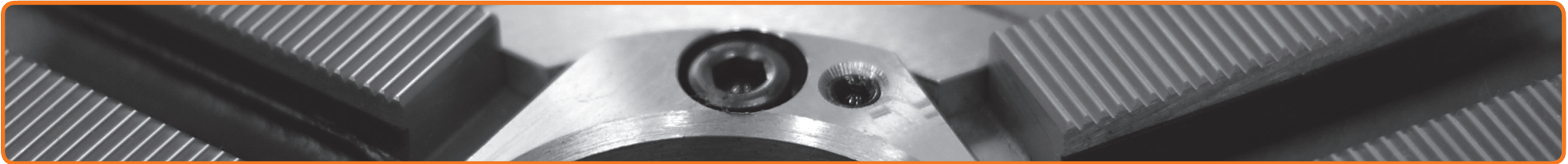

	SCHUNK	FORKARDT	RÖHM	SMW-AUTOBLOK	BERG
1/16" x 90°	HSG 140; ROTA NCD 130		KFD 140; KFD-HS 130-140		
	HSG 160; ROTA NCD 160-165	KGH/KGHF 160-175; KL/KS 160; KSF 175; KSH/KSPS 160; KT/KTG/KTN 160;KTH 160-175; NH/NHF 160-175; QLC 160-175; QLK 160-175	KFD-HE 170; KFD-HS 160-175		KH 175; KH 200
	ROTA NCF plus 185; ROTA NC plus 185; ROTA TP 160; TP 160; ROTA NCK plus 165			AL-D/AN-D 165; BB-D 175; BH-D/BHD-FC 165; GHD-FC 165; GHDN 165; HB-D 165; HFKN-D 165; HYDN-S 180; PB-D/PBI-D 165; SP/STP/STWP 160	
					KH 250; KH 315
	HSL 165; ROTA NC 165; ROTA NCD 185; ROTA NCF 165; TH/THF 165; ROTA NCO 165		KFD 160; KFD-AF 160; KFD-HF 160; KFH 160; KFH-F 160; KFH-G 160; KFH-NC 160; LVE 160; SPD 160; SPO 160	HFK/HFKS 160; KDV/KDVG 160; KFMF 160; KVF 160	HES 160; HESF 160; KF 160
	HSG 200-250		KFD-HS 200-250		
	HSL 210; ROTA NC 210; ROTA NCD 210; ROTA NCF 210; ROTA NCO 210; ROTA TP 200; TH/THF 210; TP 200; ROTA NCK plus 210-250; ROTA NCF plus 215; ROTA NC plus 215	KG/KGH/KGHF 200; KL/KLNC/KP 200; KS/KSHF 200; KSF/KSH/KSPS 200; KT/KTH/KTG/KTGF/KTN 200; NH/NHF 200; QLC/QLK 200; QLC-KS/QLK-KS 200; UVE 200	KFD 200; KFD-AF 200; KFD-HE 210; KFD-HF 200; KFH 200; KFH-F 200; KFH-G 200; KFH-NC 200; KFL 250; LVE 200; SPD 215; SPO 215	AL-D/AN-D 210; BB-D 210; BH-D/BHD-FC 210; CD 200; GHD-FC/GHDN 210; HB-D 210; HDB 220; HDN 200-220-250S; HFK/HFKS 200; HFKN-D 210; HYDN-S 210-226; KFMF 200; KVF 200; LP 205; PB-D/PBI-D 210; RCD 210; KDV/KDVG 200-250; ODL/ODN 200-220; SP/STP/STWP 200	HES 200; HESF 200; KF 200; KHFF 200
	KL/KS 250 (Monforts); KS/KSHF 250; NHF 250-290 (Index); QLC-KS/QLK-KS 250; UVE 250				
	HSL 250; ROTA NC 250; ROTA NCD 250; ROTA NCF 250; ROTA NCO 260; ROTA TP 250; TH/THF 250; TP 250; ROTA NCF plus 260; ROTA NC plus 260	KG 250; KL 250; KLNC/KP 250; KSH/KSHF 250; KSPS 250; KT/KTG/KTGF/KTN 250; NH/NHF 250; NHF 257-290; QLC/QLK 250	KFD 250; KFD-AF 250; KFD-HE 254; KFD-HF 250; KFH 250; KFH-F 250; KFH-G 250; KFH-NC 250; LVE 250	AL-D/AN-D 250; BB-D 250; BH-D 250; BHD-FC 250; CD-RCD 250; GHD-FC/GHDN 250; HB-D 250; HDL/HDN 250; HFK/HFKS 250; HFKN-D 260; HYDN-S 250; KFMF 250; KVF 250; LP 250; ODL/ODN 250; PB-D/PBI-D 250; RC-D 250-305; SP 250; STP 250	HES 250; HESF 250; KF 250; KHFF 250
	HSL 315; ROTA NC 315; ROTA NCD 315; ROTA NCF 315; ROTA NCO 315; ROTA TP 315; TH/THF 315; TP 315; ROTA NCK plus 315; ROTA NCF plus 315; ROTA NC plus 315	KG 315; KLNC/KP 315; KS 315-400; KSH/KSHF 315-400; KSPS 300; KT/KTG/KTGF/KTN 315; NH/NHF 315; NHF 400 (Index); QLC/QLK 315; QLC-KS/QLK-KS 315-400; UVE 315	KFD 315; KFD-AF 315; KFD-HE 315; KFD-HF 315; KFH 315; KFH-F 315; KFH-G 315; KFH-NC 315; KFL 315-400; LVE 305-315; SPD 300; SPO 300	AL-D/AN-D 315; BB-D 315; BH-D 315; BHD-FC 315-400; CD-RCD 315;GHD-FC/GHDN 315; HB-D 315; HDB 300; HDL/HDN 315; HFK/HFKS 315; HFKN-D 315; HYDN-S 315; KDV/KDVG 315; KFMF 315; KVF 315; ODL/ODN 315-400; PB-D/PBI-D 315; SP 350; STP 315	HES 315; HESF 315; KF 315; KHFF 315
3/32" x 90°	HSG 400-500; HSL 400; ROTA NC 400-500; ROTA NCD 400-500; ROTA NCF 400-500; ROTA NCO 400-500; TH/THF 400-500	KG 400-500; KL/KLNC 400-500; KP 400-500; KS 500; KSH 500; KSPS 400; KT/KTG 400-500; KTG/KTN 400-500; NH/NHF 400-500; QLC/QLK 400; UVE 400-500	KFD 400-500; KFD-HE 400; KFD-HF 400-500; KFD-HS 400-500; KFH 400-500; KFH-F 400-500; KFH-G 400-500; KFH-NC 400-500; KFL 500; LVE 400-500	AL-D/AN-D 400; BB-N 400-460-500 ab Bj. 98; BH-D 400-450; BHD-FC 500-630; GHD 500-610; HFK/HFKS 400-500; HFKN-D 400-500; IL-D/IN-D 500-630; KDV/KDVG 500; KVF 400-500-630; RCD 500-630	HES 400; HESF 400; KF 400; KHFF 400; HES 500; HESF 500; KF 500

- 1
- 2
- 3
- 4
- 5
- 6
- 7

Dystrybucja: unihurt.pl

Zamówienia: info@unihurt.pl



- 1
- 2
- 3
- 4
- 5
- 6
- 7
- C

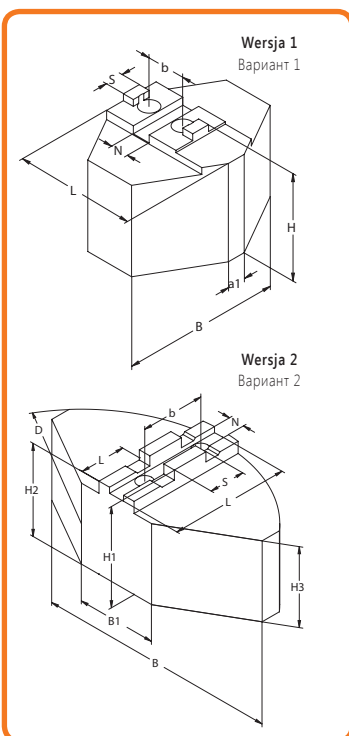

**SZCZĘKI MIĘKIE Z PEŁNYM CHWYTEM**  
 КУЛАЧКИ МЯГКИЕ СЕГМЕНТНЫЕ НАКЛАДНЫЕ

**Z WPUSTEM I ROWKIEM**  
 С СИСТЕМОЙ ПАЗ-ШПОНКА

Nr produktu	Typ szczęk	Wersja	Materiał	N	S	B	H	L	a <sub>1</sub>	B <sub>1</sub>	b	Śruby	kg / kpl.
Код продукта	Тип кулачков	Вариант	Материал									Винты	кг / кпл.
398525505000	SGM Z1MS 110-01	1	Stal/ Сталь	8	8	70	47	53	-	8	17	M 8	2,5

Nr produktu	Typ szczęk	Wersja	Materiał	N	S	B	H1	H2	L	b	Ø D	B1	H3	I	kg / kpl.
															Код продукта
398525507500	SGM Z5MS 160-01	2	Stal / Сталь	8	18	120	50	46	60	32	160	40	40	23	4,8
398525508800	SGM Z5MA 160-01	2	Alu. / Алю.	8	18	120	50	46	59,5	32	160	40	40	23	1,6
398525509000	SGM Z5MS 200-01	2	Stal / Сталь	10	20	140	60	56	70	40	200	64	50	27	8,8
398525510800	SGM Z5MS 200-02	2	Stal / Сталь	10	20	140	80	76	70	40	200	64	70	27	12,3
398525511000	SGM Z5MA 200-01	2	Alu. / Алю.	10	20	140	58	54	72,5	40	200	50	48	32	2,9
398525512300	SGM Z5MA 200-02	2	Alu. / Алю.	10	20	140	80	76	72,5	40	200	50	70	32	4,3
398525513600	SGM Z5MS 250-01	2	Stal / Сталь	12	20	180	60	55	90	40	250	70	45	44	12,8
398525514900	SGM Z5MS 250-02	2	Stal / Сталь	12	20	180	80	75	90	40	250	70	65	44	18,3
398525515100	SGM Z5MA 250-01	2	Alu. / Алю.	12	20	180	58	53	87,5	40	250	70	43	44	4,1
398525516400	SGM Z5MA 250-02	2	Alu. / Алю.	12	20	180	80	75	87,5	40	250	70	65	44	6,1
398525517700	SGM Z5MS 315-01	2	Stal / Сталь	12	26	240	75	69	110	54	320	120	60	54	28,5
398525518000	SGM Z5MA 315-01	2	Alu. / Алю.	12	26	240	75	69	117	54	320	80	60	54	9,9
398525519200	SGM Z5MS 400-01	2	Stal / Сталь	18	30	330	85	78	160	60	440	150	55	95	54,7
398525520000	SGM Z5MA 400-01	2	Alu. / Алю.	18	30	330	90	83	160	60	440	150	60	95	20,5

Ø 160 - 400 mm

Dystrybucja: unihurt.pl  
 Zamówienia: info@unihurt.pl

SGM ZM

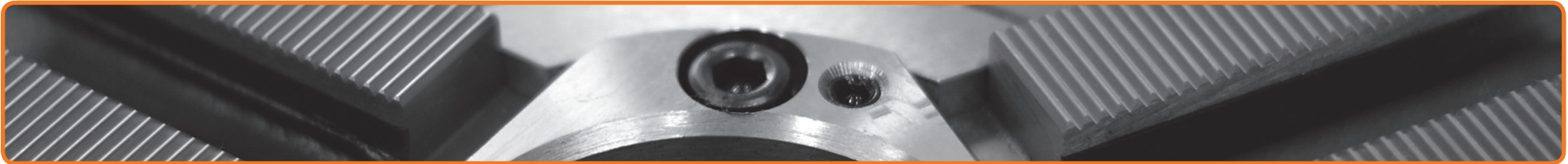

	SCHUNK	FORKARDT	RÖHM	SMW-AUTOBLOK	BERG
	KFD 110; KFD-HS 110				
	SCHUNK	FORKARDT	RÖHM	SMW-AUTOBLOK	BERG
Ø 160 - 400 mm	ROTA-G 160; ROTA NCW 185; ROTA-S 160; ROTA-S plus 160; ROTA THW 165; ROTA THW plus 165-185; THW 165	F 160; F+ 160; FNC 175; KTNC 160; KTNCV 160-175	DURO 160; DURO-NC 160-175; DURO-NCE 160-175; DURO-NCES 175	HG 160; HG-F 160; HG-N 160; KNCS 160-175; KNCS-N 170; KNSP 160; RMG 160	KHNC 160; KHNC 185
	ROTA-G 200; ROTA NCW 225; ROTA NCWF 210; ROTA-S 200; ROTA-S plus 200; ROTA THW 210; ROTA THW plus 215; ROTA THWB 210; THW 210 R/F; ROTA THW vario 215	F 200; F+ 200; FNC 200; KTNC 200; KTNCV 200	DURO 200; DURO-NC 200-225; DURO-NCE 200; DURO-NCES 200	HG 200; HG-F 210; HG-N 210; KNCS 200-210; KNCS-N 210-225; KNCS-NB 210; KNSP 200; RMG 200	KHNC 200
	ROTA-G 250-315; ROTA NCW 265-315; ROTA NCWF 250-315; ROTA-S 250; ROTA-S plus 250; ROTA THW 250-315; ROTA THW plus 260-315; ROTA THWB 265; THW 250-265-R/F; THW 315-R	F 250; F+ 250; FNC 250-315; KTNC/KTNCV 250-315; UNC 250-315	DURO 250; DURO-NC 250; DURO-NCE 250-315; DURO-NCES 250; DURO-NCES 315	HG 250-315; HG-F 260; HG-N 260-315; KNCS 250-315; KNCS-N 260-275-315-340; KNCS-NB 260; RMG 250	KHNC 250; KHNC 315
	ROTA-G 400; ROTA-S 315; ROTA-S plus 315; ROTA THW 400; ROTA THWB 315; THW 315-F; THW 400-R/F	F 315; F+ 315; FNC 400; KTNC 360-400; KTNCV 400; UNC 400	DURO 315; DURO-NC 315; DURO-NCE 400; DURO-NCES 315; DURO-NCES 400	HG-F 315; HG 400; HG-N 400; KNCS/KNCS-N 400; RMG 315	KHNC 400
	ROTA-G 500; ROTA-S 400-500; ROTA-S plus 400-500; ROTA THW 500-630; ROTA THWB 400-500; THW 500-R/F; THW 630-R	F 400-500 L; F+ 400-500 L; FNC 500-630; KTNC/KTNCV 500-630; UNC 500	DURO 400-500; DURO-NC 400-500; DURO-NCE 500; DURO-NCES 400	HG 500-630; HG-N 500-630; HG-F 400-500; KNCS 500-630; KNCS-N 500-630	

- 1
- 2
- 3
- 4
- 5
- 6
- 7

Dystrybucja: [unihurt.pl](http://unihurt.pl)  
  
 Zamówienia: [info@unihurt.pl](mailto:info@unihurt.pl) **SGM**



**SZCZĘKI GÓRNE TWARDE**  
 КУЛАЧКИ КАЛЕННЫЕ НАКЛАДНЫЕ

**METRYCZNA WIELKOŚĆ KĄTA ZĄBKÓW 1,5 mm x 60°**  
 МЕТРИЧЕСКОЕ ЗУБЧАТОЕ СОЕДИНЕНИЕ 1,5 мм x 60°

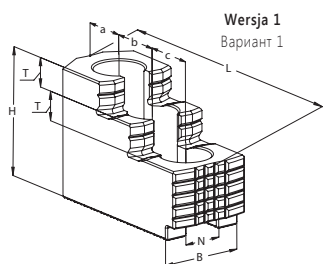

Wersja 1  
 Вариант 1

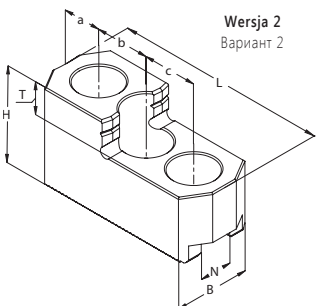

Wersja 2  
 Вариант 2

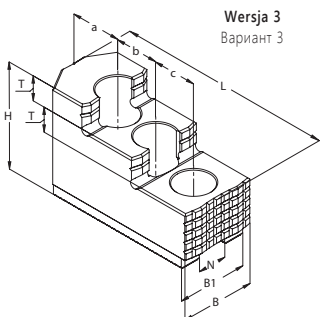

Wersja 3  
 Вариант 3

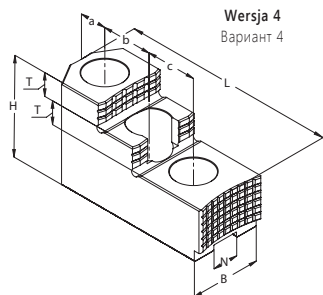

Wersja 4  
 Вариант 4

1,5 mm x 60°

Nr produktu	Typ szczęk	Wersja	N	B	H	L	T	a + b + c	Śruby	kg / kpl.
Код продукта	Тип кулачков	Вариант							Винты	кг / кпл.
398522575800	SGT M160-11-60	1	11	26	37,5	62	10	17,5 + 16,5 + 16,5	M 8	0,7
398522576000	SGT M160-12-60	2	12	28	36	67	12	14 + 20 + 20	M 10	0,8
398522578600	SGT M200-14-80	1	14	35	51	87	12	15,5 + 25 + 25	M 12	1,9
398522577300	SGT M200-14-15	3	14	36	52,5	81	12	25 + 21 + 21	M 10	1,9
398522579900	SGT M250-16-00	1	16	40	54	101,5	13	25,5 + 30 + 30	M 12	2,9
398522580600	SGT M315-20-80	1	20	44,5	54	96	12	30 + 26 + 26	M 12	3,0
398522581900	SGT M315-21-26	1	21	50	62	128	14	22 + 30 + 30	M 16	5,0
398522582100	SGT M400-22-50	4	22	60	86	143	20	23,5 + 43 + 43	M 20	8,6



Wkładki teowe  
 Т-образные вкладки str. 492-501  
 str. 492-501



Materiał szczęk  
 Материал кулачков



Wielkość kąta ząbków  
 Зубчатое соединение



- 1
- 2
- 3
- 4
- 5
- 6
- 7
- C

SGT M



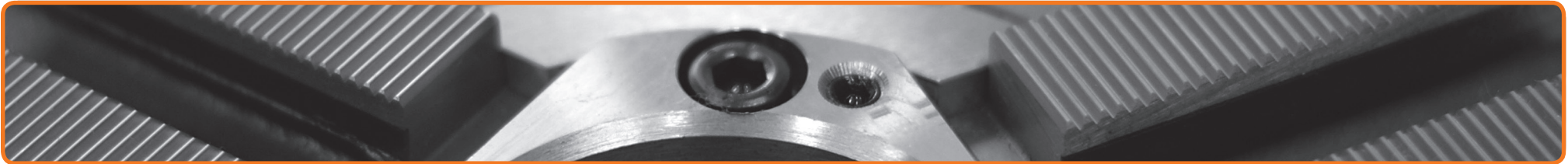

	SCHUNK	KITAGAWA	RÖHM	SMW-AUTOBLOK	HOWA - MMK / MATSUMOTO
1,5 mm x 60°			KFG 160; KFM 160; KFN 160; KFE 170		ZA 5-6-42
	ROTA NCK 165; HSL 165; ROTA NC/NCF 165; ROTA NCD 165-185; ROTA NCK plus 165; ROTA NC plus 185; ROTA NCF plus 185	AS 165; B 06; BB 06; B 106; B 160; B 206; BB 206; B 7; B 07; HJA 5-6; HO 6; HOB 6; HOH 06; HOH 106; HOH 160; HOH 206; HOS 6; N 06; N 160	KFD-HE 170	AL-M 165; AN-M 165; BB-M 175; BH-M 165; BH-M FC 165; HB-M 165; HFKN-M 165; PB-M/PBI-M 165	HO 7 MA 6; HO 15 M 6; HO 22 M 6; HO 24 M 6; HO 27 M 6; HO 37 M 6; HO 47 M 6 YA 5-6-46; ZA 5-6-46
	ROTA NCK 210; HSL 210; ROTA NCD 210; ROTA NC/NCF 210; ROTA NCK plus 210; ROTA NC plus 215; ROTA NCF plus 215	AS 210; B 08; B 108; B 200; B 208; BB 08; BB 208; HJA 6-8; HO 8; HOB 8; HOH 8; HOH 108; HOH 200; HOH 208; HOS 8; N 08; N 200	KFD-HE 210	AL-M 210; AN-M 210; BB-M 210; BH-M 210; BH-M FC 210; HB-M 210; HFKN-M 210; PB-M/PBI-M 210	HO 7 MA 8; HO 15 M 8; HO 23 M 8; ZA 6-8-52; ZA 6-8-66
			KFE 215; KFG 215; KFM 215		
	ROTA NCK 250; HSL 250; ROTA NC/NCF/NCD 250; ROTA NCK plus 250; ROTA NC plus 260; ROTA NCF plus 260	AS 250; B 10; B 110; B 210; B 250; BB 10; BB 210; HJA 6-10; HJA 8-10; HO 10; HOB 10; HOH 10; HOH 110; HOH 210; HOH 250; HOS 10; N 10; N 250	KFD-HE 254	AL-M 250; AN-M 250; BB-M 250; BH-M 250; BH-M FC 250; HBM 250; HFKN-M 260; PB-M/PBI-M 250	ZA 8-10-66; HA 8-10-66; ZA 6-10-75
			KFE 280; KFG 280; KFM 280; KFN 250-280		
	ROTA NCK 315; HSL 315; ROTA NCD 315; ROTA NCK plus 315; ROTA NC plus 315; ROTA NCF plus 315	B 112; B 212; BB 212; HOH 112; HOH 212	KFD-HE 315	AL-M 315; AN-M 315; BB-M 305-315; BH-M 315; BH-M FC 315; HB-M 305-315; HFKN-M 315; PB-M/PBI-M 315; RC-M 305-315	HO 27 M 12; HO 37 M 12; HO 47 M 12
ROTA NC/NCF 400	B 15; B 380; B 18; B 215; B 450; HOB 15; HOB 18; HOH 15; HOH 15-K; N 15				

1

2

3

4

5

6

7

Dystrybucja: unihurt.pl



Zamówienia: info@unihurt.pl LGS





1  
2  
3  
4  
5  
6  
7  
C

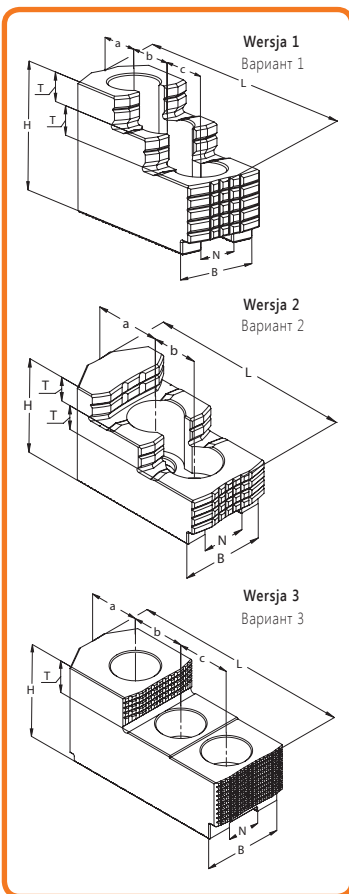

**SZCZĘKI GÓRNE TWARDE**  
 КУЛАЧКИ КАЛЕННЫЕ НАКЛАДНЫЕ

**CAŁOWA WIELKOŚĆ KĄTA ZĄBKÓW 1/16" x 90° LUB 3/32" x 90°**  
 ДЮЙМОВОЕ ЗУБЧАТОЕ СОЕДИНЕНИЕ 1/16" x 90° ИЛИ 3/32" x 90°

	Nr produktu	Typ szczęk	Wersja	N	B	H	L	T	a + b (+c)	Śruby	kg / kpl.
	Код продукта	Тип кулачков	Вариант							Винты	кг / кпл.
1/16" x 90°	398522560200	SGT C125-11-25	1	11	26	40	58,5	9	14,5 + 16 + 16	M 8	0,7
	398522561500	SGT C135-10-30	1	10	26	37,5	56	10	10 + 12 + 12	M 6	0,6
	398522562800	SGT C135-12-30	1	12	30	38	57	10	16 + 15 + 15	M 8	0,7
	398522563000	SGT C160-10-32	1	10	25	38	66,5	6,5	17 + 19 + 17	M 10	0,7
	398522564300	SGT C160-14-65	1	14	30	46	78	11	16 + 22 + 22	M 10	1,3
	398522566900	SGT C160-17-75	2	17	35	40	64,7	10	28 + 19	M 12	1,0
	398522565600	SGT C160-17-00	1	17	40	49	72,5	12	18 + 19 + 19	M 12	1,6
	398522567100	SGT C200-12-37	1	12	30	44	79	8	23 + 21 + 21	M 12	1,3
	398522568400	SGT C200-17-10	1	17	40	49	84	12	29 + 19 + 19	M 12	2,1
	398522570400	SGT C250-21-50	1	21	50	58	103,5	14	34 + 25 + 25	M 16	3,5
3/32" x 90°	398522569700	SGT C250-16-40	1	16	40	60	112	12	33 + 29 + 29	M 16	2,8
	398522571700	SGT C315-21-15	1	21	50	58	128	14	46 + 30 + 30	M 16	4,7
	398522572000	SGT C400-25,5-00	1	25,5	60	75	140	18	53 + 31 + 31	M 20	7,6
	398522573200	SGT C500-25,5-00	3	25,5	57	73	160	22	40 + 42 + 42	M 18	10,0
	398522574500	SGT C630-30-30	3	30	75	88	175	30	48 + 50 + 50	M 24	16,3

**Wkładki teowe** str. 492-501  
 Т-образные вкладки стр.

Dystrybucja: unihurt.pl  
 Zamówienia: info@unihurt.pl

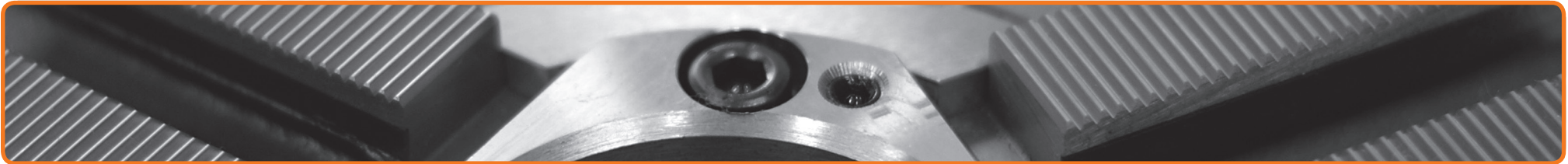

	SCHUNK	FORKARDT	RÖHM	SMW-AUTOBLOK	BERG
1/16" x 90°	ROTA TP 125; TP 125			SP/STP 125 bis Bj. 98; HFKS 130-32	
	HSG 140; ROTA NCD 130		KFD 110-125; KFD 140; KFD-HS 125-130-140		
	HSG 160; ROTA NCD 160-165		KFD 130; KFD-HE 170; KFD-HS 160-175; KFH 140; LVE 125; LVE 160	AL-D/AN-D 125; BH-D 130; HB-D 130; KDV 130; PB-D/PBI-D 130; SP/STP 125 ab Bj. 98; BH-D 140	KF 130
					KH 140; KH 160
	ROTA TP 160; TP 160; ROTA NCK plus 165; ROTA NC plus 185; ROTA NCF plus 185; ROTA NCR 250-315			AL-D/AN-D 165; BB-D 175; BH-D/BHD-FC 165; GHD-FC 165; GHDN 165; HB-D 165; HFKN-D 165; HYDN-S 180; PBD/PBI-D 165; SP/STP/STWP 160	
	HSL 165; ROTA NC 165; ROTA NCD 185; ROTA NCF 165; TH/THF 165; ROTA NCO 165	KGH/KGHF 160-175; KL/KS 160; KSF 175; KSH/KSPS 160; KT/KTG/KTN 160; KTH 160-175; NH/NHF 160-175; QLC 160-175; QLK 160-175; UVE 160	KFD 160; KFD-AF 160; KFD-HF 160; KFD-HS 200; KFH 160; KFH-F 160; KFH-G 160; KFH-NC 160; LVE 160; SPD 160; SPO 160	HFH/HFKS 160; KDV/KDVG 160; KFMF 160; KVF 160	HES 160; HESF 160; KF 160
3/32" x 90°	HSG 200; HSL 210; ROTA NC 210; TP 200; ROTA NCD 210; ROTA NCF 210; TH/THF 210; ROTA NCO 210; ROTA TP 200; ROTA NCK plus 210-250; ROTA NC plus 215; ROTA NCF plus 215	KG/KGH/KGHF 200; KL/KLNC/KP 200; KS/KSHF 200-250; KSF/KSH/KSPS 200; KT/KTH/KTG/KTGF/KTN 200; NH/NHF 200; QLC/QLK 200; QLC-KS/QLK-KS 200-250; KL/KS 250 (Monforts); NHF 250-290 (Index); UVE 200-250	KFD 200; KFD-AF 200; KFD-HE 210; KFD-HF 200; KFD-HS 200; KFD-HS 250; KFH 200; KFH-F 200; KFH-G 200; KFH-NC 200; KFL 250; LVE 200; SPD 215; SPO 215	AL-D/AN-D 210; BB-D 210; BHD/BHD-FC 210; CD 200; GHD-FC/GHDN 210; HB-D 210; HDB 220; HDN 200-220-250S; HFH/HFKS 200; HFKN-D 210; HYDN-S 210-226; KFMF 200; KVF 200; LP 205; PB-D/PBI-D 210; RCD 210; KDV/KDVG 200-250; ODL/ODN 200-220; SP/STP/STWP 200	KH 175; KH 200
	HSG 315; HSL 250; ROTA NC 250; ROTA NCD 250; ROTA NCF 250; ROTA NC plus 260; ROTA NCF plus 260; ROTA NCO 260; ROTA TP 250; TH/THF 250; TP 250	KG 250; KL 250; KLNC/KP 250; KSH/KSHF 250; KSPS 250-300; KT/KTG/KTGF/KTN 250; NH/NHF 250; NHF 257-290; QLC/QLK 250	KFD 250; KFD-AF 250; KFD-HE 254; KFD-HF 250; KFD-HS 315; KFH 250; KFH-F 250; KFH-G 250; KFH-NC 250; LVE 250-305	AL-D/AN-D 250; BB-D 250; BH-D 250; BH-D-FC 250; CD 250; GHD-FC/GHDN 250; HB-D 250; HDL/HDN 250; HFH/HFKS 250; HFKN-D 260; HYDN-S 250; KFMF 250; KVF 250; LP 250; ODL/ODN 250; PB-D/PBI-D 250; RCD 250-305; SP 250; STP 250	HES 250; HESF 250; KF 250; KHFF 250
					KH 250; KH 315
	HSL 315; ROTA NC 315; ROTA NCD 315; ROTA NCF 315; ROTA NCO 315; ROTA TP 315; ROTA NC plus 315; ROTA NCF plus 315; TH/THF 315; TP 315; ROTA NCK plus 315; ROTA EP 500	KG 315; KLNC/KP 315; KS 315-400; KSH/KSHF 315-400; KSPS 300; KT/KTG 315; KTGF/KTN 315; NH/NHF 315; NHF 400 (Index); QLC/QLK 315; QLC-KS/QLK-KS 315-400; UVE 315	KFD 315; KFD-AF 315; KFD-HE 315; KFD-HF 315; KFH 315; KFH-F 315; KFH-G 315; KFH-NC 315; KFL 315-400; LVE 315; SPD 300; SPO 300; KFD-HS 315	AL-D/AN-D 315; BB-D 315; BH-D 315; BH-D FC 315; CD/RCD 315; GHD-FC/GHDN 315; HB-D 315; HDB 300; HDL/HDN 315; HFH/HFKS 315; HFKN-D 315; HYDN-S 315; KDV/KDVG 315; KFMF 315; KVF 315; ODL/ODN 315-400; PB-D/PBI-D 315; SP 350; STP 315	HES 315; HESF 315; KF 315; KHFF 315
	HSG 400-500; HSL 400; ROTA NC 400-500; ROTA NCD 400-500; ROTA NCF 400-500; ROTA NCO 400-500; TH/THF 400-500	KG 400-500; KL/KLNC 400-500; KP 400-500; KS 500-630; KSH 500; KSHF 630; KS-L 630; KSPS 400; KT/KTG 400-630; KTG/KTN 400-500; NH/NHF 400-630; QLC/QLK 400; UVE 400-800	KFD 400-500-630-800; KFD-HE 400; KFD-HF 400-500-630; KFD-HS 400-500; KFH 400-500; KFH-F 400-500; KFH-G 400-500; KFH-NC 400-500; KFL 500-600; LVE 400-500-630-800	AL-D/AN-D 400; BB-N 400-460-500 ab Bj. 98; BH-D 400-450; BHD-FC 500-630; GHD 500-610-640-800; HFH/HFKS 400-500; HFKN-D 400-500; IL-D/IN-D 500-630-800; KDV/KDVG 500; KVF 400-500-630-800; RCD 500-630; BH-D 630-800	HES 400; HESF 400; KF 400; KHFF 400; HES 500; HESF 500; KF 500; HES 630; HESF 630; KF 630
	ROTA EP 380-460; ROTA TB 400-500-610; ROTA TB-LH 630-265; TB 400-500; ROTA TB-LH 400-500-610			BB 400-500; BB 400-500 ES; BB 630-265 ES; LP 380-460-500; STP 400-500	
ROTA NC 630; ROTA TB 630-265; ROTA TB-LH 630-325; TB 630					

- 1
- 2
- 3
- 4
- 5
- 6
- 7

Dystrybucja: unihurt.pl  
Zamówienia: info@unihurt.pl  
LGS



- 1
- 2
- 3
- 4
- 5
- 6
- 7
- C

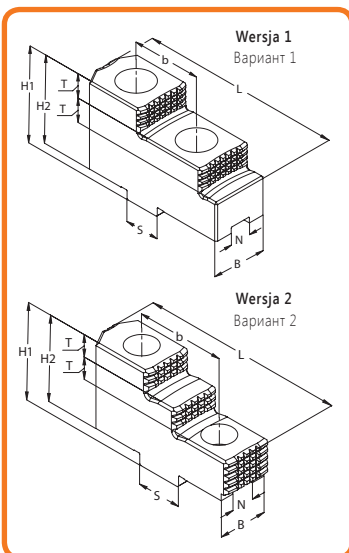

**SZCZĘKI GÓRNE TWARDE**  
 КУЛАЧКИ КАЛЕННЫЕ НАКЛАДНЫЕ

**Z WPUSTEM I ROWKIEM**  
 С СИСТЕМОЙ ПАЗ-ШПОНКА

Nr produktu	Typ szczęk	Wersja	N	S	B	H1	H2	L	T	b	kg / kpl.
											Код продукта
398531080000	SGT 160 F	2	8	18	20	37	32,5	63	7,5	32	0,6
398531086700	SGT 200 F	2	10	20	22	43	38	72	10	40	0,8
398531087000	SGT 250 F	1	12	20	32	55	50	90	14	40	2,1
398531088200	SGT 315 F	1	12	26	36	62	56	104	15	54	3,3
398531089500	SGT 400 F	1	18	30	45	82	75	130	20	60	6,7

Ø 160 - 400 mm

Dystrybucja: [unihurt.pl](mailto:unihurt.pl)  
 Zamówienia: [info@unihurt.pl](mailto:info@unihurt.pl)



Zamówienia: [info@unihurt.pl](mailto:info@unihurt.pl)

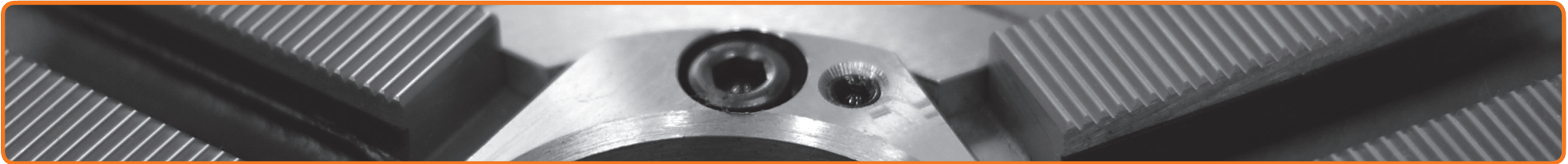

	SCHUNK	FORKARDT	RÖHM	SMW-AUTOBLOK	BERG
Ø 160 - 400 mm	ROTA-G 160; ROTA NCW 185; ROTA-S 160; ROTA-S plus 160; ROTA THW 165; ROTA THW plus 165-185; THW 165	F 160; F+ 160; FNC 175; KTNC 160; KTNCV 160-175	DURO 160; DURO-NC 140-160-175; DURO-NCE 160-175; DURO-NCES 175	HG 160; HG-F 160; HG-N 160; KNCS 160-175; KNCS-N 170; KNSP 160; RMG 160	KHNC 160; KHNC 185
	ROTA-G 200; ROTA NCW 225; ROTA NCWF 210; ROTA-S 200; ROTA-S plus 200; ROTA THW 210; ROTA THW plus 215; ROTA THWB 210; THW 210 R/F; ROTA THW vario 215	F 200; F+ 200; FNC 200; KTNC 200; KTNCV 200	DURO 200; DURO-NC 200-225; DURO-NCE 200; DURO-NCES 200	HG 200; HG-F 210; HG-N 210; KNCS 200-210; KNCS-N 210-225; KNCS-NB 210; KNSP 200; RMG 200	KHNC 200
	ROTA-G 250-315; ROTA NCW 265-315; ROTA NCWF 250-315; ROTA-S 250; ROTA-S plus 250; ROTA THW 250-315; ROTA THW plus 260-315; ROTA THWB 265; THW 250-265-R/F; THW 315-R	F 250; F+ 250; FNC 250-315; KTNC/KTNCV 250-315; UNC 250-315	DURO 250; DURO-NC 250; DURO-NCE 250-315; DURO-NCES 250; DURO-NCES 315	HG 250-315; HG-F 260; HG-N 260-315; KNCS 250-315; KNCS-N 260-275-315-340; KNCS-NB 260; KNCS-NB 315; RMG 250	KHNC 250; KHNC 315
	ROTA-G 400; ROTA-S 315; ROTA-S plus 315; ROTA THW 400; ROTA THWB 315; THW 315-F; THW 400-R/F	F 315; F+ 315; FNC 400; KTNC 360-400; KTNCV 400; UNC 400	DURO 315; DURO-NC 315; DURO-NCE 400; DURO-NCES 315; DURO-NCES 400	HG-F 315; HG 400; HG-N 400; KNCS/KNCS-N 400; KNCS-NB 400; RMG 315	KHNC 400
	ROTA-G 500; ROTA-S 400-500; ROTA-S plus 400-500; ROTA THW 500-630-800; ROTA THWB 400-500; THW 500-R/F; THW 630-R	F 400-500 L; F+ 400-500 L; FNC 500-630; KTNC/KTNCV 500-630; UNC 500	DURO 400-500; DURO-NC 400-500; DURO-NCE 500; DURO-NCES 400	HG 500-630; HG-N 500-630; HG-F 400-500; KNCS 500-630; KNCS-N 500-630; KNCS-NB 500-630-800	

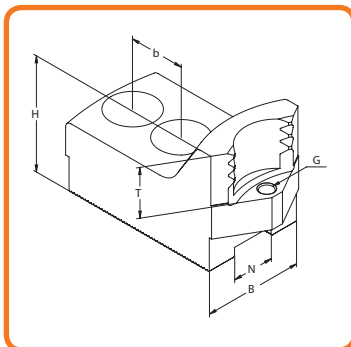

**SZCZĘKI CHWYTAKOWE - MOCOWANIE WEWNĘTRZNE**  
 КУЛАЧКИ ЗУБЧАТЫЕ - ВНУТРЕННИЙ ЗАЖИМ

**METRYCZNA WIELKOŚĆ KĄTA ZĄBKÓW 1,5 mm x 60°**  
 МЕТРИЧЕСКОЕ ЗУБЧАТОЕ СОЕДИНЕНИЕ 1,5 мм x 60°

- 1
- 2
- 3
- 4
- 5
- 6
- 7

- **Możliwość regulacji głębokości mocowania przedmiotu obrabianego „T”, za pomocą wymiennych kołków опорowych.**
- **Śruby nie wchodzą w zakres dostawy i muszą być zamawiane oddzielnie.**
- **Возможность регулировки глубины крепления обрабатываемой детали «Т» при помощи съемных опорных шпилек.**
- **Эти шпильки не входят в комплект поставки и должны быть заказаны отдельно.**

Ø 160 - 200 mm

Nr produktu	Typ szczęk	N	B	H	T	G	b	Śruby	kg / kpl.
Код продукта	Тип кулачков							Винты	кг / кпл.
398522666000	SWKB M160-12-06	12	30	47	20	M 6	20	M 10	1,3
398522667200	SWKB M160-12-07	12	30	47	20	M 6	20	M 10	1,1
398522668500	SWKB M160-12-08	12	30	47	20	M 6	20	M 10	1,0
398522669800	SWKB M160-12-09	12	35	47	20	M 6	20	M 10	1,1
398522670500	SWKB M160-12-10	12	40	47	20	M 6	20	M 10	1,3
398522671800	SWKB M200-14-01	14	35	53	25	M 6	25	M 12	2,0
398522672000	SWKB M200-14-02	14	35	53	25	M 6	25	M 12	1,6
398522673300	SWKB M200-14-03	14	40	53	25	M 6	25	M 12	1,6
398522674600	SWKB M200-14-04	14	40	53	25	M 6	25	M 12	1,6
398522675900	SWKB M200-14-16	14	40	53	25	M 6	25	M 12	1,8

**Kołki опорowe** str. 503  
 Опорные шпильки стр.

**Wkładki teowe** str. 492-501  
 Т-образные вкладки стр.

Dystrybucja: unihurt.pl  
 Zamówienia: info@unihurt.pl

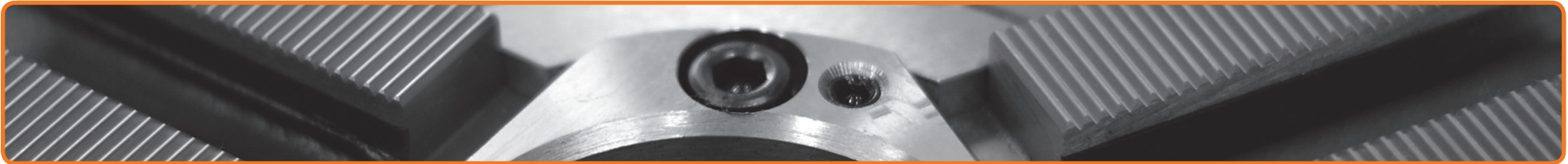

Ø 160 - 200 mm	SCHUNK			KITAGAWA			SMW-AUTOBLOK			HOWA				
	Zakres mocowania	Max. wysięg szczęk	Typ uchwytu	Zakres mocowania	Max. wysięg szczęk	Typ uchwytu	Zakres mocowania	Max. wysięg szczęk	Typ uchwytu	Zakres mocowania	Max. wysięg szczęk	Typ uchwytu		
	Диапазон зажима	Макс. вылет кулачков	Тип патрона	Диапазон зажима	Макс. вылет кулачков	Тип патрона	Диапазон зажима	Макс. вылет кулачков	Тип патрона	Диапазон зажима	Макс. вылет кулачков	Тип патрона		
31 - 50	170	ROTA NCK 165; ROTA NCK plus 165	31 - 52	172	B 206	33 - 65	185	AL-M 165	27 - 56	181	HO 7 MA 6			
			31 - 52	172	HOH 6; HOH 206	29 - 58	178	AN-M 165	32 - 52	177	HO 22 M 6			
			32 - 47	166	N 160; N 6	38 - 69	190	BB-M 175	27 - 52	177	HO 27 M 6			
			36 - 54	174	BB 06; BB 206	28 - 58	178	BH-M 165						
						31 - 56	176	HFKN-M 165						
			42 - 65	170	ROTA NCK 165; ROTA NCK plus 165	42 - 67	172	B 206	49 - 81	185	AL-M 165	48 - 68	175	HO 22 M 6
						32 - 65	170	B 160; B 6	43 - 74	178	AN-M 165			
						42 - 67	172	HOH 6; HOH 206	54 - 85	190	BB-M 175			
						47 - 63	166	N 160; N 6	42 - 74	178	BH-M 165			
						51 - 69	174	BB 06; BB 206	46 - 72	176	HFKN-M 165			
						58 - 81	170	B 206	65 - 97	185	AL-M 165	56 - 88	178	HO 7 MA 6
			58 - 81	170	ROTA NCK 165; ROTA NCK plus 165	47 - 81	170	B 160; B 6	59 - 90	178	AN-M 165	64 - 84	173	HO 22 M 6
						58 - 83	172	HOH 6; HOH 206	70 - 101	190	BB-M 175	48 - 84	173	HO 27 M 6
						63 - 77	166	N 160; N 6	58 - 90	178	BH-M 165			
						67 - 85	174	BB 06; BB 206	62 - 88	176	HFKN-M 165			
						72 - 97	172	B 206	79 - 111	185	AL-M 165	78 - 98	174	HO 22 M 6
						61 - 95	170	B 160; B 6	73 - 104	178	AN-M 165			
			72 - 95	170	ROTA NCK 165; ROTA NCK plus 165	72 - 97	172	HOH 6; HOH 206	84 - 115	190	BB-M 175			
						77 - 93	166	N 160; N 6	72 - 104	178	BH-M 165			
						81 - 99	174	BB 06; BB 206	76 - 102	176	HFKN-M 165			
88 - 113	172	B 206				95 - 127	185	AL-M 165	81 - 118	178	HO 7 MA 6			
77 - 111	170	B 160; B 6				89 - 120	178	AN-M 165	94 - 118	173	HO 22 M 6			
88 - 113	172	HOH 6; HOH 206				100 - 131	190	BB-M 175	71 - 114	173	HO 27 M 6			
88 - 111	170	ROTA NCK 165; ROTA NCK plus 165	93 - 107	166	N 160; N 6	88 - 120	178	BH-M 165						
			97 - 115	174	BB 06; BB 206	92 - 118	176	HFKN-M 165						
			35 - 64	211	B 208	45 - 79	225	AL-M 210	34 - 72	211	HO 7 MA 8			
			33 - 61	208	B 200; B 8	36 - 69	216	AN-M 210	34 - 78	211	HO 23 M 8			
			35 - 64	211	HOH 8; HOH 208	41 - 71	218	BB-M 210						
			42 - 68	212	N 200; N 8	33 - 70	217	BH-M 210						
62 - 90	209	ROTA NCK 210; ROTA NCK plus 210	42 - 64	211	BB 08; BB 208	42 - 81	228	HFKN-M 210						
			62 - 92	211	B 208	73 - 107	225	AL-M 210	62 - 100	218	HO 7 MA 8			
			47 - 89	208	B 200; B 8	63 - 97	216	AN-M 210	62 - 106	218	HO 23 M 8			
			62 - 92	211	HOH 8; HOH 208	68 - 99	218	BB-M 210						
			68 - 96	216	N 200; N 8	54 - 98	217	BH-M 210						
			70 - 92	211	BB 08; BB 208	69 - 109	228	HFKN-M 210						
92 - 121	209	ROTA NCK 210; ROTA NCK plus 210	92 - 122	211	B 208	103 - 137	225	AL-M 210	92 - 130	218	HO 7 MA 8			
			77 - 119	208	B 200; B 8	94 - 127	216	AN-M 210	92 - 136	223	HO 23 M 8			
			92 - 122	211	HOH 8; HOH 208	98 - 129	218	BB-M 210						
			98 - 128	217	N 200; N 8	84 - 128	217	BH-M 210						
			100 - 122	211	BB 08; BB 208	100 - 139	228	HFKN-M 210						
			122 - 153	211	B 208	133 - 167	225	AL-M 210	122 - 160	218	HO 7 MA 8			
122 - 151	209	ROTA NCK 210; ROTA NCK plus 210	113 - 150	208	B 200; B 8	124 - 158	216	AN-M 210	122 - 166	223	HO 23 M 8			
			122 - 153	211	HOH 8; HOH 208	128 - 160	218	BB-M 210						
			128 - 153	212	N 200; N 8	114 - 159	217	BH-M 210						
			131 - 153	211	BB 08; BB 208	130 - 170	228	HFKN-M 210						
			144 - 173	229	B 208				150 - 180	238	HO 7 MA 8			
			135 - 170	226	B 200; B 8				150 - 187	245	HO 23 M 8			
144 - 173	229	ROTA NCK 210; ROTA NCK plus 210	144 - 173	229	HOH 8; HOH 208									
			153 - 173	230	N 200; N 8									
			153 - 174	229	BB 08; BB 208									

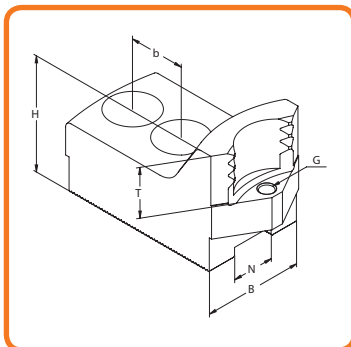

**SZCZĘKI CHWYTAKOWE - MOCOWANIE WEWNĘTRZNE**  
 КУЛАЧКИ ЗУБЧАТЫЕ - ВНУТРЕННИЙ ЗАЖИМ

**METRYCZNA WIELKOŚĆ KĄTA ZĄBKÓW 1,5 mm x 60°**  
 МЕТРИЧЕСКОЕ ЗУБЧАТОЕ СОЕДИНЕНИЕ 1,5 мм x 60°

- Możliwość regulacji głębokości mocowania przedmiotu obrabianego „T”, za pomocą wymiennych kołków опорowych.
- Śruby nie wchodzą w zakres dostawy i muszą być zamawiane oddzielnie.
- Возможность регулировки глубины крепления обрабатываемой детали «Т» при помощи съемных опорных шпилек.
- Эти шпильки не входят в комплект поставки и должны быть заказаны отдельно.

Nr produktu	Typ szczęk	N	B	H	T	G	b	Śruby		kg / kpl.
								Винты	кг / кпл.	
398522676100	SWKB M200-16-05	16	35	53	25	M 6	25	M 12	1,8	
398522677400	SWKB M200-16-06	16	35	53	25	M 6	25	M 12	1,6	
398522678700	SWKB M200-16-07	16	40	53	25	M 6	25	M 12	1,4	
398522679000	SWKB M200-16-08	16	40	53	25	M 6	25	M 12	1,4	
398522680700	SWKB M250-16-01	16	40	58	25	M 6	30	M 12	3,0	
398522681000	SWKB M250-16-02	16	40	58	25	M 6	30	M 12	2,4	
398522682200	SWKB M250-16-03	16	40	58	25	M 6	30	M 12	2,1	
398522683500	SWKB M250-16-04	16	40	58	25	M 6	30	M 12	2,0	
398522684800	SWKB M250-16-15	16	40	58	25	M 6	30	M 12	2,7	
398522685000	SWKB M250-18-09	18	40	58	25	M 6	30	M 14	2,7	
398522686300	SWKB M250-18-10	18	40	58	25	M 6	30	M 14	2,1	
398522687600	SWKB M250-18-11	18	45	58	25	M 6	30	M 14	1,9	
398522688900	SWKB M250-18-12	18	45	58	25	M 6	30	M 14	2,3	
398522689100	SWKB M315-18-01	18	50	65	25	M 8	30	M 14	5,0	
398522690900	SWKB M315-18-02	18	50	65	25	M 8	30	M 14	3,7	
398522691100	SWKB M315-18-03	18	50	65	25	M 8	30	M 14	3,3	
398522692400	SWKB M315-18-04	18	50	65	25	M 8	30	M 14	4,6	

Ø 200 - 315 mm

**Kołki опорowe** str. 503  
 Опорные шпильки стр.

**Wkładki teowe** str. 492-501  
 Т-образные вкладки стр.

Dystrybucja: unihurt.pl  
 Zamówienia: info@unihurt.pl



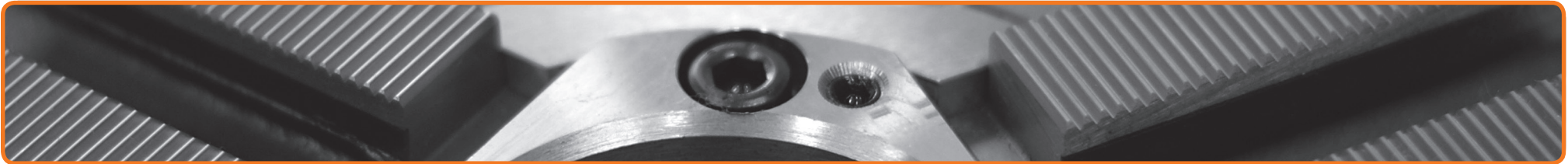

Ø 200 - 315 mm	SCHUNK			KITAGAWA			SMW-AUTOBLOK			HOWA		
	Zakres mocowania	Max. wysięg szczęk	Typ uchwytu	Zakres mocowania	Max. wysięg szczęk	Typ uchwytu	Zakres mocowania	Max. wysięg szczęk	Typ uchwytu	Zakres mocowania	Max. wysięg szczęk	Typ uchwytu
	Диапазон зажима	Макс. вылет кулачков	Тип патрона	Диапазон зажима	Макс. вылет кулачков	Тип патрона	Диапазон зажима	Макс. вылет кулачков	Тип патрона	Диапазон зажима	Макс. вылет кулачков	Тип патрона
										38 - 70	214	HO 22 M 8
										30 - 68	214	HO 27 M 8
										66 - 98	214	HO 22 M 8
										48 - 96	214	HO 27 M 8
										96 - 128	218	HO 22 M 8
										78 - 126	213	HO 27 M 8
										126 - 158	218	HO 22 M 8
										108 - 155	213	HO 27 M 8
	43 - 81	258	ROTA NCK 250; ROTA NCK plus 250	43 - 84	260	B 210	55 - 93	269	AL-M 250			
				40 - 81	258	B 250; B 10	43 - 81	258	AN-M 250			
				38 - 79	255	HOH 10 K; HOH 250	52 - 81	258	BB-M 250			
				37 - 78	255	N 250; N 10	42 - 80	257	BH-M 250			
				48 - 74	251	BB 10; BB 210	40 - 81	258	HFKN-M 260			
	84 - 123	258	ROTA NCK 250; ROTA NCK plus 250	84 - 128	260	B 210	97 - 135	269	AL-M 250			
				76 - 123	258	B 250; B 10	85 - 123	258	AN-M 250			
				79 - 123	255	HOH 10 K; HOH 250	94 - 123	258	BB-M 250			
				78 - 122	257	N 250; N 10	83 - 122	257	BH-M 250			
				90 - 116	251	BB 10; BB 210	76 - 123	258	HFKN-M 260			
	128 - 167	262	ROTA NCK 250; ROTA NCK plus 250	128 - 173	264	B 210	141 - 179	273	AL-M 250			
				120 - 167	262	B 250; B 10	128 - 167	262	AN-M 250			
				123 - 168	259	HOH 10 K; HOH 250	138 - 167	262	BB-M 250			
				122 - 167	263	N 250; N 10	127 - 166	261	BH-M 250			
				134 - 160	255	BB 10; BB 210	119 - 167	262	HFKN-M 260			
	173 - 212	278	ROTA NCK 250; ROTA NCK plus 250	173 - 214	280	B 210	176 - 224	289	AL-M 250			
				165 - 212	278	B 250; B 10	173 - 213	278	AN-M 250			
				168 - 209	275	HOH 10 K; HOH 250	183 - 213	278	BB-M 250			
				167 - 208	274	N 250; N 10	172 - 212	277	BH-M 250			
				179 - 205	271	BB 10; BB 210	164 - 213	278	HFKN-M 260			
	202 - 260	322	ROTA NCK 250; ROTA NCK plus 250	208 - 247	310	B 210	208 - 258	320	AL-M 250			
				203 - 242	305	B 250; B 10	208 - 248	310	AN-M 250			
				203 - 242	305	HOH 10 K; HOH 250	218 - 248	310	BB-M 250			
				202 - 242	304	N 250; N 10	207 - 247	309	BH-M 250			
				214 - 241	303	BB 10; BB 210	207 - 266	328	HFKN-M 260			
										38 - 88	262	HO 22 M 10
										38 - 90	264	HO 27 M 10
										80 - 130	262	HO 22 M 10
										76 - 132	264	HO 27 M 10
										118 - 168	265	HO 22 M 10
										120 - 176	268	HO 27 M 10
										169 - 219	286	HO 22 M 10
										165 - 221	286	HO 27 M 10
				45 - 108	320	B 300; B 12						
				45 - 110	322	HOH 12 K; HOH 300						
				42 - 116	328	N 300; N 12						
				93 - 168	334	B 300; B 12						
				99 - 170	336	HOH 12 K; HOH 300						
				102 - 176	342	N 300; N 12						
				158 - 234	325	B 300; B 12						
				163 - 236	327	HOH 12 K; HOH 300						
				166 - 242	333	N 300; N 12						
				227 - 299	370	B 300; B 12						
				228 - 301	372	HOH 12 K; HOH 300						
				231 - 307	378	N 300; N 12						



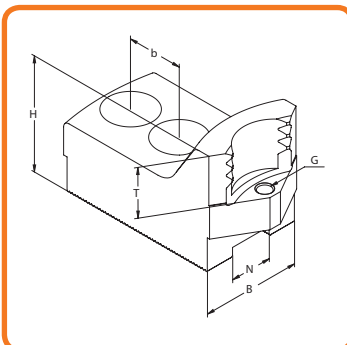

**SZCZĘKI CHWYTAKOWE - MOCOWANIE WEWNĘTRZNE**  
 КУЛАЧКИ ЗУБЧАТЫЕ - ВНУТРЕННИЙ ЗАЖИМ

**METRYCZNA WIELKOŚĆ KĄTA ZĄBKÓW 1,5 mm x 60°**  
 МЕТРИЧЕСКОЕ ЗУБЧАТОЕ СОЕДИНЕНИЕ 1,5 мм x 60°

- Możliwość regulacji głębokości mocowania przedmiotu obrabianego „T”, za pomocą wymiennych kołków опорowych.
- Śruby nie wchodzą w zakres dostawy i muszą być zamawiane oddzielnie.
- Возможность регулировки глубины крепления обрабатываемой детали «Т» при помощи съемных опорных шпилек.
- Эти шпильки не входят в комплект поставки и должны быть заказаны отдельно.

Nr produktu	Typ szczęk	N	B	H	T	G	b	Śruby	kg / kpl.
								Винты	кг / кпл.
398522693700	SWKB M315-21-05	21	50	65	25	M 8	30	M 16	5,0
398522694000	SWKB M315-21-06	21	50	65	25	M 8	30	M 16	3,9
398522695200	SWKB M315-21-07	21	50	65	25	M 8	30	M 16	3,4
398522696500	SWKB M315-21-08	21	50	65	25	M 8	30	M 16	4,5
398522697800	SWKB M400-22-01	22	60	85	33	M 8	43	M 20	10,6
398522698000	SWKB M400-22-02	22	60	85	33	M 8	43	M 20	9,2
398522699300	SWKB M400-22-03	22	60	85	33	M 8	43	M 20	6,5
398522700300	SWKB M400-22-04	22	60	85	33	M 8	43	M 20	7,0
398522701600	SWKB M400-22-05	22	60	85	33	M 8	43	M 20	8,2
398522702900	SWKB M400-22-06	22	60	85	33	M 8	43	M 20	9,5

Ø 315 - 400 mm

**Kołki опорowe** str. 503  
 Опорные шпильки стр.

**Wkładki teowe** str. 492-501  
 Т-образные вкладки стр.

Dystrybucja: unihurt.pl Zamówienia: info@unihurt.pl

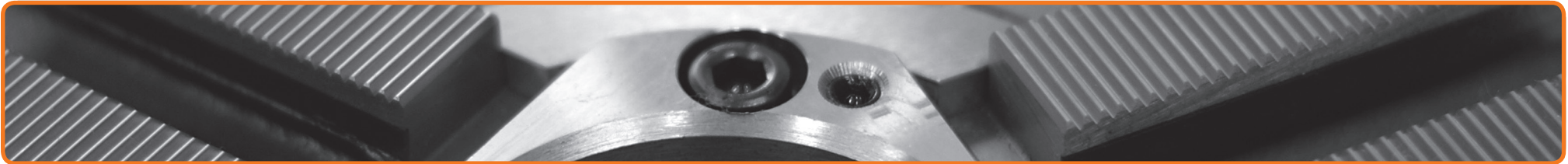

SCHUNK			KITAGAWA			SMW-AUTOBLOK		
Zakres mocowania	Max. wysięg szczęk	Typ uchwytu	Zakres mocowania	Max. wysięg szczęk	Typ uchwytu	Zakres mocowania	Max. wysięg szczęk	Typ uchwytu
Диапазон зажима	Макс. вылет кулачков	Тип патрона	Диапазон зажима	Макс. вылет кулачков	Тип патрона	Диапазон зажима	Макс. вылет кулачков	Тип патрона
48 - 109	321	ROTA NCK 315; ROTA NCK plus 315	45 - 111	323	B 212	57 - 139	349	AL-M 315
			59 - 120	332	BB 212	45 - 125	336	AN-M 315
						85 - 124	335	BB-M 315
108 - 169	335	ROTA NCK 315; ROTA NCK plus 315	108 - 173	337	B 212	54 - 125	336	BH-M 315
			119 - 180	346	BB 212	70 - 137	348	HFKN-M 315
						117 - 199	363	AL-M 315
						100 - 184	350	AN-M 315
						144 - 183	349	BB-M 315
173 - 235	326	ROTA NCK 315; ROTA NCK plus 315	173 - 238	328	B 212	114 - 184	350	BH-M 315
						130 - 196	362	HFKN-M 315
						182 - 264	399	AL-M 315
						165 - 250	341	AN-M 315
						210 - 249	340	BB-M 315
						179 - 250	341	BH-M 315
238 - 300	371	ROTA NCK 315; ROTA NCK plus 315	184 - 246	337	BB 212	195 - 262	353	HFKN-M 315
			238 - 302	373	B 212	247 - 315	385	AL-M 315
						230 - 316	386	AN-M 315
						275 - 315	385	BB-M 315
						244 - 316	386	BH-M 315
						260 - 315	385	HFKN-M 315
						169 - 133	414	ALM 400
						159 - 123	404	ANM 400
						249 - 311	382	BB 212
						50 - 107	390	B 380; B 15; HOH 15 K
Ø 315 - 400 mm			50 - 105	388	HOH 380; HOH 15			
			47 - 97	381	B 215			
			49 - 167	451	B 18			
			96 - 160	394	B 380; B 15	126 - 190	420	ALM 400
			98 - 161	392	HOH 380; HOH 15	116 - 180	410	ANM 400
			106 - 166	396	HOH 15 K			
			90 - 154	386	B 215			
			105 - 225	457	B 18			
			156 - 220	394	B 380; B 15	186 - 250	420	ALM 400
			158 - 221	392	HOH 380; HOH 15	176 - 240	410	ANM 400
			166 - 226	396	HOH 15 K			
			148 - 214	386	B 215			
			165 - 285	457	B 18			
			216 - 280	415	B 380; B 15	247 - 311	441	ALM 400
		218 - 280	412	HOH 380; HOH 15	237 - 301	431	ANM 400	
		226 - 286	417	HOH 15 K				
		209 - 276	407	B 215				
		225 - 346	478	B 18				
		276 - 340	431	B 380; B 15	307 - 371	457	ALM 400	
		278 - 340	428	HOH 380; HOH 15	297 - 361	447	ANM 400	
		286 - 346	433	HOH 15 K				
		268 - 336	423	B 215				
		285 - 407	494	B 18				
		336 - 400	483	B 380; B 15	367 - 400	478	ALM 400	
		338 - 400	480	HOH 380; HOH 15	357 - 400	478	ANM 400	
		346 - 400	485	HOH 15 K				
		328 - 396	475	B 215				
		345 - 467	546	B 18				

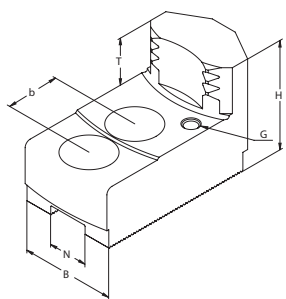

**SZCZĘKI CHWYTAKOWE - MOCOWANIE ZEWNĘTRZNE**

КУЛАЧКИ ЗУБЧАТЫЕ - ВНЕШНИЙ ЗАЖИМ

**METRYCZNA WIELKOŚĆ KĄTA ZĄBKÓW 1,5 mm x 60°**

МЕТРИЧЕСКОЕ ЗУБЧАТОЕ СОЕДИНЕНИЕ 1,5 мм x 60°

Nr produktu	Typ szczęk	N	B	H	T	G	b	Śruby	kg / kpl.
								Винты	кг / кпл.
398522617300	SZKB M200-14-01	14	35	53	20	M 6	25	M 12	2,0
398522618600	SZKB M200-14-02	14	40	53	20	M 6	25	M 12	2,2
398522619900	SZKB M200-14-03	14	40	53	20	M 6	25	M 12	2,0
398522620600	SZKB M200-14-04	14	40	53	20	M 6	25	M 12	1,7
398522621900	SZKB M250-16-01	16	40	58	25	M 6	30	M 12	3,1
398522622100	SZKB M250-16-02	16	40	58	25	M 6	30	M 12	2,8
398522623400	SZKB M250-16-03	16	40	58	25	M 6	30	M 12	2,4
398522624700	SZKB M250-16-04	16	40	58	25	M 6	30	M 12	2,2

Ø 200 - 250 mm

Możliwość regulacji głębokości mocowania przedmiotu obrabianego „T”, za pomocą wymiennych kołków опорowych.

Śruby nie wchodzą w zakres dostawy i muszą być zamawiane oddzielnie.

Возможность регулировки глубины крепления обрабатываемой детали «Т» при помощи съемных опорных шпилек.

Эти шпильки не входят в комплект поставки и должны быть заказаны отдельно.

**Kołki опорowe** str. 503  
 Опорные шпильки стр.

**Wkładki teowe** str. 492-501  
 Т-образные вкладки стр.

Dystrybucja: unihurt.pl Zamówienia: info@unihurt.pl

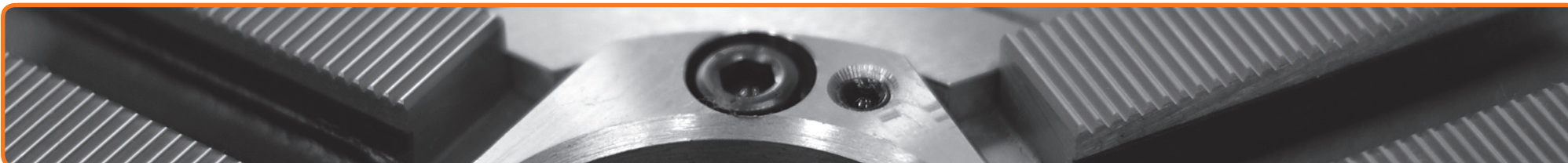

Ø 200 - 250 mm	SCHUNK			KITAGAWA			SMW-AUTOBLOK			HOWA				
	Zakres mocowania	Max. wysięg szczęk	Typ uchwytu	Zakres mocowania	Max. wysięg szczęk	Typ uchwytu	Zakres mocowania	Max. wysięg szczęk	Typ uchwytu	Zakres mocowania	Max. wysięg szczęk	Typ uchwytu		
	Диапазон зажима	Макс. вылет кулачков	Тип патрона	Диапазон зажима	Макс. вылет кулачков	Тип патрона	Диапазон зажима	Макс. вылет кулачков	Тип патрона	Диапазон зажима	Макс. вылет кулачков	Тип патрона		
60 - 78	219	ROTA NCK 210; ROTA NCK plus 210	60 - 78	213	B 208	58 - 85	219	AL-M 210	60 - 84	221	HO 7 MA 8			
			60 - 78	213	B 200; B 8	60 - 85	220	AN-M 210	60 - 91	225	HO 23 M 8			
			60 - 78	213	HOH 8; HOH 208	57 - 87	222	BB-M 210						
			60 - 78	214	N 200; N 8	58 - 87	221	BH-M 210						
			58 - 79	215	BB 08; BB 208									
			80 - 108	219	ROTA NCK 210; ROTA NCK plus 210	73 - 80	213	B 208	81 - 115	219	AL-M 210	76 - 114	223	HO 7 MA 8
						79 - 108	214	B 200; B 8	81 - 115	220	AN-M 210	76 - 121	225	HO 23 M 8
						73 - 108	213	HOH 8; HOH 208	86 - 117	222	BB-M 210			
						79 - 108	214	N 200; N 8	74 - 117	221	BH-M 210			
						88 - 110	215	BB 08; BB 208						
			110 - 139	209	ROTA NCK 210; ROTA NCK plus 210	103 - 139	209	B 208	111 - 145	219	AL-M 210	106 - 144	218	HO 7 MA 8
						106 - 139	209	B 200; B 8	112 - 146	216	AN-M 210	106 - 151	220	HO 23 M 8
						103 - 139	209	HOH 8; HOH 208	116 - 147	218	BB-M 210			
						109 - 139	210	N 200; N 8	101 - 147	217	BH-M 210			
						118 - 141	211	BB 08; BB 208						
			140 - 168	219	ROTA NCK 210; ROTA NCK plus 210	133 - 168	219	B 208	141 - 175	219	AL-M 210	136 - 174	228	HO 7 MA 8
						138 - 168	219	B 200; B 8	141 - 175	226	AN-M 210	136 - 181	230	HO 23 M 8
						133 - 168	219	HOH 8; HOH 208	146 - 177	228	BB-M 210			
						139 - 169	220	N 200; N 8	131 - 177	227	BH-M 210			
						148 - 171	221	BB 08; BB 208						
60 - 98	260	ROTA NCK 250; ROTA NCK plus 250	63 - 98	260	B 210	62 - 99	259	AL-M 250						
			63 - 93	255	B 250; B 10	61 - 99	260	AN-M 250						
			63 - 93	255	HOH 10 K; HOH 250	70 - 99	260	BB-M 250						
			63 - 93	254	N 250; N 10	62 - 98	258	BH-M 250						
			66 - 92	253	BB 10; BB 210									
100 - 138	260	ROTA NCK 250; ROTA NCK plus 250	92 - 138	260	B 210	101 - 139	259	AL-M 250						
			95 - 133	255	B 250; B 10	100 - 139	260	AN-M 250						
			95 - 134	255	HOH 10 K; HOH 250	110 - 139	260	BB-M 250						
			95 - 133	254	N 250; N 10	100 - 138	258	BH-M 250						
			106 - 132	253	BB 10; BB 210									
137 - 176	256	ROTA NCK 250; ROTA NCK plus 250	129 - 176	256	B 210	138 - 176	255	AL-M 250						
			128 - 170	251	B 250; B 10	137 - 177	256	AN-M 250						
			124 - 171	251	HOH 10 K; HOH 250	147 - 177	256	BB-M 250						
			123 - 170	250	N 250; N 10	137 - 175	254	BH-M 250						
			143 - 169	249	BB 10; BB 210									
171 - 210	266	ROTA NCK 250; ROTA NCK plus 250	162 - 210	266	B 210	172 - 210	265	AL-M 250						
			160 - 205	260	B 250; B 10	171 - 211	266	AN-M 250						
			157 - 205	261	HOH 10 K; HOH 250	181 - 211	266	BB-M 250						
			157 - 204	260	N 250; N 10	171 - 209	264	BH-M 250						
			177 - 203	259	BB 10; BB 210									

- 1
- 2
- 3
- 4
- 5
- 6
- 7

Dystrybucja: unihurt.pl  

 Zamówienia: info@unihurt.pl IKZS

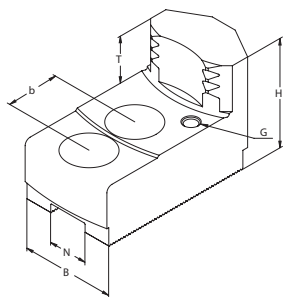

**SZCZĘKI CHWYTAKOWE - MOCOWANIE ZEWNĘTRZNE**  
 КУЛАЧКИ ЗУБЧАТЫЕ - ВНЕШНИЙ ЗАЖИМ

**METRYCZNA WIELKOŚĆ KĄTA ZĄBKÓW 1,5 mm x 60°**  
 МЕТРИЧЕСКОЕ ЗУБЧАТОЕ СОЕДИНЕНИЕ 1,5 мм x 60°

- Możliwość regulacji głębokości mocowania przedmiotu obrabianego „T”, za pomocą wymiennych kołków опорowych.
- Śruby nie wchodzą w zakres dostawy i muszą być zamawiane oddzielnie.
- Возможность регулировки глубины крепления обрабатываемой детали «Т» при помощи съемных опорных шпилек.
- Эти шпильки не входят в комплект поставки и должны быть заказаны отдельно.

Ø 315 - 400 mm

Nr produktu	Typ szczęk	N	B	H	T	G	b	Śruby	kg / kpl.
Код продукта	Тип кулачков							Винты	кг / кпл.
398522625000	SZKB M315-18-09	18	50	65	25	M 8	30	M 14	5,0
398522626200	SZKB M315-18-10	18	50	65	25	M 8	30	M 14	4,2
398522627500	SZKB M315-18-11	18	50	65	25	M 8	30	M 14	3,4
398522628800	SZKB M315-18-12	18	50	65	25	M 8	30	M 14	4,0
398522629000	SZKB M315-21-13	21	50	65	25	M 8	30	M 16	5,1
398522630800	SZKB M315-21-14	21	50	65	25	M 8	30	M 16	4,3
398522631000	SZKB M315-21-15	21	50	65	25	M 8	30	M 16	3,4
398522632300	SZKB M315-21-16	21	50	65	25	M 8	30	M 16	3,9
398522633600	SZKB M400-22-01	22	60	85	33	M 8	43	M 20	10,2
398522634900	SZKB M400-22-02	22	60	85	33	M 8	43	M 20	9,1
398522635100	SZKB M400-22-03	22	60	85	33	M 8	43	M 20	7,0
398522636400	SZKB M400-22-04	22	60	85	33	M 8	43	M 20	5,8
398522637700	SZKB M400-22-05	22	60	85	33	M 8	43	M 20	8,0

**Kołki опорowe** str. 503  
 Опорные шпильки стр.

**Wkładki teowe** str. 492-501  
 Т-образные вкладки стр.

Dystrybucja: unihurt.pl  
 Zamówienia: info@unihurt.pl

SZKB M

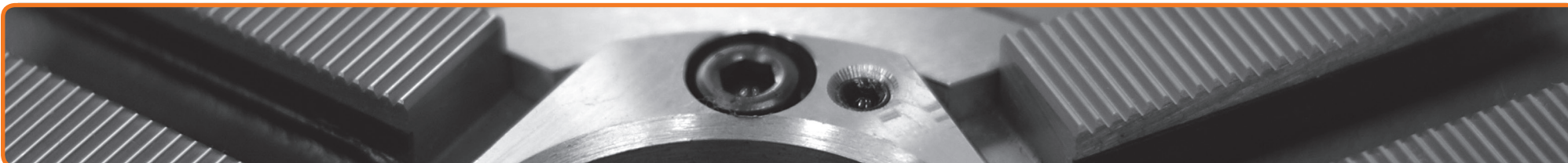

SCHUNK			KITAGAWA			SMW-AUTOBLOK					
Zakres mocowania	Max. wysięg szczęk	Typ uchwytu	Zakres mocowania	Max. wysięg szczęk	Typ uchwytu	Zakres mocowania	Max. wysięg szczęk	Typ uchwytu			
Диапазон зажима	Макс. вылет кулачков	Тип патрона	Диапазон зажима	Макс. вылет кулачков	Тип патрона	Диапазон зажима	Макс. вылет кулачков	Тип патрона			
Ø 315 - 400 mm	78 - 138	ROTA NCK 315; ROTA NCK plus 315	81 - 140	315	B 12; N 12;	80 - 153	327	AL-M 315			
			81 - 137	314	HOH 12 K; HOH 300						
			123 - 204	320	B 12; N 12;						
			118 - 199	320	HOH 12 K; HOH 300						
			186 - 258	308	B 12; N 12;						
			182 - 263	301	HOH 12 K; HOH 300						
			238 - 310	358	B 12; N 12;						
			234 - 315	356	HOH 12 K; HOH 300						
			81 - 138	315	B 212				81 - 153	330	AN-M 315
			79 - 138	315	BB 212				114 - 152	329	BB-M 315
	138 - 199	ROTA NCK 315; ROTA NCK plus 315	128 - 199	321	B 212	85 - 155	329	BH-M 315			
			138 - 200	321	BB 212	131 - 213	333	AL-M 315			
						130 - 215	336	AN-M 315			
						175 - 214	335	BB-M 315			
	202 - 264	ROTA NCK 315; ROTA NCK plus 315	191 - 264	305	B 212	145 - 215	335	BH-M 315			
			202 - 264	305	BB 212	195 - 277	317	AL-M 315			
						194 - 279	320	AN-M 315			
						239 - 278	319	BB-M 315			
	254 - 316	ROTA NCK 315; ROTA NCK plus 315	243 - 316	357	B 212	209 - 279	319	BH-M 315			
			254 - 316	357	BB 212	247 - 329	369	AL-M 315			
					246 - 331	372	AN-M 315				
					291 - 330	371	BB-M 315				
						261 - 331	371	BH-M 315			
			100 - 160	384	B 380; B 15	113 - 177	399	ALM 400			
			100 - 160	384	HOH 380; HOH 15	113 - 179	401	ANM 400			
			100 - 161	385	HOH 15 K						
			158 - 215	392	B 380; B 15	168 - 232	404	ALM 400			
			156 - 218	390	HOH 380; HOH 15	168 - 234	406	ANM 400			
			152 - 217	390	HOH 15 K						
			208 - 270	390	B 380; B 15	223 - 291	403	ALM 400			
			210 - 273	389	HOH 380; HOH 15	223 - 293	405	ANM 400			
			204 - 272	385	HOH 15 K						
			271 - 339	395	B 380; B 15	293 - 357	409	ALM 400			
			274 - 340	394	HOH 380; HOH 15	293 - 359	411	ANM 400			
			274 - 342	395	HOH 15 K						
			334 - 400	443	B 380; B 15	353 - 405	447	ALM 400			
			337 - 401	446	HOH 380; HOH 15	353 - 405	447	ANM 400			
			333 - 402	445	HOH 15 K						

1  
2  
3  
4  
5  
6  
7  
Dystrybucja: unihurt.pl  
Zamówienia: info@unihurt.pl  
IKZS

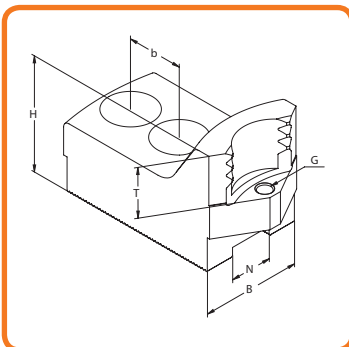

**SZCZĘKI CHWYTAKOWE - MOCOWANIE WEWNĘTRZNE**  
 КУЛАЧКИ ЗУБЧАТЫЕ - ВНУТРЕННИЙ ЗАЖИМ

**CAŁOWA WIELKOŚĆ KĄTA ZĄBKÓW 1/16" x 90°**  
 ДЮЙМОВОЕ ЗУБЧАТОЕ СОЕДИНЕНИЕ 1/16" x 90°

- Możliwość regulacji głębokości mocowania przedmiotu obrabianego „T”, za pomocą wymiennych kołków опорowych.
- Śruby nie wchodzą w zakres dostawy i muszą być zamawiane oddzielnie.
- Возможность регулировки глубины крепления обрабатываемой детали «Т» при помощи съемных опорных шпилек.
- Эти шпильки не входят в комплект поставки и должны быть заказаны отдельно.

Nr produktu	Typ szczęk	N	B	H	T	G	b	Śruby		kg / kpl.
								Винты	кг / кпл.	
398522703100	SWKB C160-12-10	12	32	40	20	M 5	2 x 15	M 8	0,9	
398522704400	SWKB C160-12-11	12	32	40	20	M 5	2 x 15	M 8	0,8	
398522705700	SWKB C160-12-12	12	32	40	20	M 5	2 x 15	M 8	0,8	
398522710500	SWKB C160-17-30	17	35	50	20	M 5	19	M 12	1,3	
398522711800	SWKB C160-17-31	17	35	50	20	M 5	19	M 12	1,2	
398522712000	SWKB C160-17-32	17	35	50	20	M 5	19	M 12	1,1	
398522713300	SWKB C160-17-33	17	40	50	20	M 5	19	M 12	1,2	
398522714600	SWKB C160-17-34	17	40	50	20	M 5	19	M 12	1,5	
398522715900	SWKB C200-12-70	12	35	50	20	M 6	21	M 12	1,8	
398522716100	SWKB C200-12-71	12	35	50	20	M 6	21	M 12	1,5	
398522717400	SWKB C200-12-72	12	35	50	20	M 6	21	M 12	1,2	
398522718700	SWKB C200-12-73	12	35	50	20	M 6	21	M 12	1,2	
398522719000	SWKB C200-12-74	12	35	50	20	M 6	21	M 12	1,3	
398522720700	SWKB C200-12-75	12	35	50	20	M 6	21	M 12	1,5	
398522721000	SWKB C200-12-76	12	35	50	20	M 6	21	M 12	1,9	

**Kołki опорowe** str. 503  
 Опорные шпильки стр.

**Wkładki teowe** str. 492-501  
 Т-образные вкладки стр.

Dystrybucja: unihurt.pl Zamówienia: info@unihurt.pl



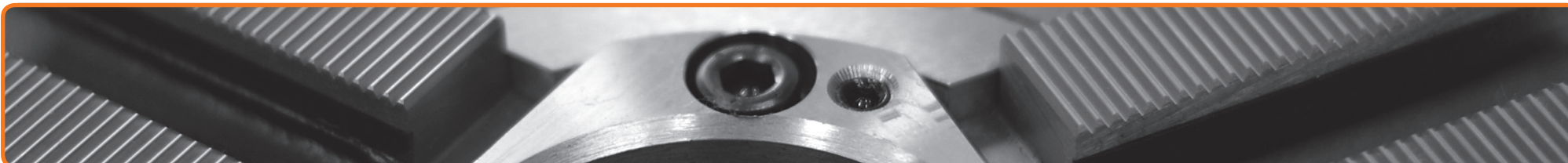

Ø 160 - 200 mm	SCHUNK			FORKARDT			RÖHM			SMW-AUTOBLOK			BERG		
	Zakres mocowania	Max. wysięg szczęk	Typ uchwytu	Zakres mocowania	Max. wysięg szczęk	Typ uchwytu	Zakres mocowania	Max. wysięg szczęk	Typ uchwytu	Zakres mocowania	Max. wysięg szczęk	Typ uchwytu	Zakres mocowania	Max. wysięg szczęk	Typ uchwytu
	Диапазон зажима	Макс. вылет кулачков	Тип патрона	Диапазон зажима	Макс. вылет кулачков	Тип патрона	Диапазон зажима	Макс. вылет кулачков	Тип патрона	Диапазон зажима	Макс. вылет кулачков	Тип патрона	Диапазон зажима	Макс. вылет кулачков	Тип патрона
	35 - 64	171	HSG 160				29 - 63	170	KFD-HS 160						
	32 - 70	178	ROTA NCD 160-165				38 - 73	188	KFD-HS 175						
	63 - 104	181	HSG 160				64 - 91	168	KFD-HS 160						
	60 - 98	176	ROTA NCD 160-165				66 - 102	179	KFD-HS 175						
	83 - 134	191	HSG 160				85 - 111	168	KFD-HS 160						
	85 - 118	176	ROTA NCD 160-165				86 - 122	179	KFD-HS 175						
	43 - 61	173	HSL 165	33 - 52	164	NH/NHF 160	28 - 52	164	KFD 160	38 - 62	175	HFKS/KFMF 160	30 - 48	160	HES/HESH 160
	38 - 60	173	ROTA NC/TH 165; ROTA NCF/THF 165	30 - 55	169	KGH/KGHF 160	30 - 52	164	KFD-HF 160	30 - 53	166	KDV/KDVG/KFV 160	30 - 44	156	KF 160
				30 - 55	169	KS/KT/KTG 160	36 - 52	164	KFH 160						
				41 - 67	184	KGH/KGHF 175									
				41 - 67	184	KSF/KTH 175									
				29 - 59	171	QLC 160									
				33 - 67	179	QLC/QLK 175									
	62 - 82	175	HSL 165	52 - 71	164	NH/NHF 160	46 - 71	164	KFD 160	58 - 82	175	HFKS/KFMF 160	46 - 68	160	HES/HESH 160
	58 - 79	173	ROTA NC/TH 165; ROTA NCF/THF 165	50 - 72	169	KGH/KGHF 160	49 - 71	164	KFD-HF 160	50 - 73	166	KDV/KDVG/KFV 160	42 - 64	156	KF 160
				50 - 72	169	KS/KT/KTG 160	55 - 71	164	KFH 160						
				61 - 87	184	KGH/KGHF 175									
				61 - 87	184	KSF/KTH 175									
				43 - 78	171	QLC 160									
				51 - 86	179	QLC/QLK 175									
	83 - 103	174	HSL 165	74 - 94	164	NH/NHF 160	68 - 94	164	KFD 160	80 - 104	178	HFKS/KFMF 160	68 - 90	160	HES/HESH 160
	79 - 102	173	ROTA NC/TH 165; ROTA NCF/THF 165	70 - 94	169	KGH/KGHF 160	71 - 94	164	KFD-HF 160	70 - 93	166	KDV/KDVG/KFV 160	64 - 86	156	KF 160
				70 - 94	169	KS/KT/KTG 160	77 - 94	164	KFH 160						
				83 - 109	184	KGH/KGHF 175									
				83 - 109	184	KSF/KTH 175									
				66 - 100	171	QLC 160									
				74 - 108	179	QLC/QLK 175									
	102 - 122	182	HSL 165	92 - 112	172	NH/NHF 160	86 - 112	172	KFD 160	100 - 122	183	HFKS/KFMF 160	86 - 110	170	HES/HESH 160
	98 - 120	181	ROTA NC/TH 165; ROTA NCF/THF 165	90 - 114	180	KGH/KGHF 160	89 - 112	172	KFD-HF 160	90 - 113	174	KDV/KDVG/KFV 160	82 - 106	166	KF 160
				90 - 114	180	KS/KT/KTG 160	95 - 112	172	KFH 160						
				103 - 129	194	KGH/KGHF 175									
				103 - 129	194	KSF/KTH 175									
				83 - 119	179	QLC 160									
				91 - 127	187	QLC/QLK 175									
	123 - 143	202	HSL 165	114 - 134	192	NH/NHF 160	108 - 134	192	KFD 160	120 - 144	203	HFKS/KFMF 160	106 - 130	190	HES/HESH 160
	119 - 142	201	ROTA NC/TH 165; ROTA NCF/THF 165	115 - 135	199	KGH/KGHF 160	111 - 134	192	KFD-HF 160	110 - 135	194	KDV/KDVG/KFV 160	102 - 126	186	KF 160
				115 - 135	199	KS/KT/KTG 160	117 - 134	192	KFH 160						
				123 - 149	214	KGH/KGHF 175									
				123 - 149	214	KSF/KTH 175									
				105 - 140	199	QLC 160									
				113 - 148	207	QLC/QLK 175									
													38 - 60	187	KH 175
													52 - 84	210	KH 200
													52 - 74	185	KH 175
													66 - 98	210	KH 200
													74 - 96	185	KH 175
													88 - 120	210	KH 200
													96 - 118	185	KH 175
													110 - 142	210	KH 200
													118 - 140	185	KH 175
													132 - 164	210	KH 200
													140 - 162	205	KH 175
													150 - 185	230	KH 200
													160 - 182	225	KH 175
													174 - 206	250	KH 200

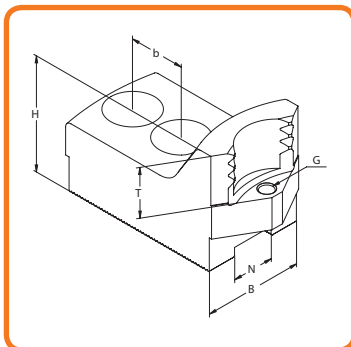

**SZCZĘKI CHWYTAKOWE - MOCOWANIE WEWNĘTRZNE**  
 КУЛАЧКИ ЗУБЧАТЫЕ - ВНУТРЕННИЙ ЗАЖИМ

**CAŁOWA WIELKOŚĆ KĄTA ZĄBKÓW 1/16" x 90°**  
 ДЮЙМОВОЕ ЗУБЧАТОЕ СОЕДИНЕНИЕ 1/16" x 90°

- Możliwość regulacji głębokości mocowania przedmiotu obrabianego „T”, za pomocą wymiennych kołków опорowych.
- Śruby nie wchodzą w zakres dostawy i muszą być zamawiane oddzielnie.
- Возможность регулировки глубины крепления обрабатываемой детали «Т» при помощи съемных опорных шпилек.
- Эти шпильки не входят в комплект поставки и должны быть заказаны отдельно.

Ø 160 - 200 mm

Nr produktu	Typ szczęk	N	B	H	T	G	b	Śruby	kg / kpl.
Код продукта	Тип кулачков							Винты	кг / кпл.
398522706000	SWKB C160-14-01	14	30	47	20	M 6	20	M 10	1,2
398522707200	SWKB C160-14-02	14	30	47	20	M 6	20	M 10	1,0
398522708500	SWKB C160-14-03	14	30	47	20	M 6	20	M 10	0,9
398522709800	SWKB C160-14-04	14	35	47	20	M 6	20	M 10	1,1
398522722200	SWKB C200-17-14	17	35	50	25	M 6	22	M 12	1,6
398522723500	SWKB C200-17-15	17	35	50	25	M 6	22	M 12	1,4
398522724800	SWKB C200-17-16	17	40	50	25	M 6	22	M 12	1,4
398522725000	SWKB C200-17-17	17	40	50	25	M 6	22	M 12	1,3
398522726300	SWKB C200-17-18	17	40	50	25	M 6	22	M 12	1,6

**Kołki опорowe** str. 503  
 Опорные шпильки стр.

**Wkładki teowe** str. 492-501  
 Т-образные вкладки стр.

Dystrybucja: unihurt.pl  
 Zamówienia: info@unihurt.pl

SWKB C

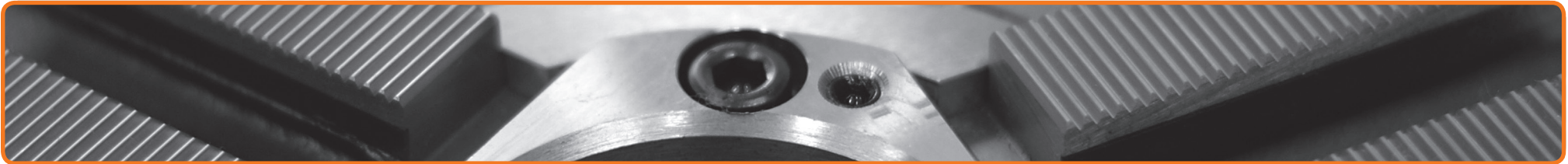

Ø 160 - 200 mm	SCHUNK			FORKARDT			RÖHM			SMW-AUTOBLOK			BERG		
	Zakres mocowania	Max. wysięg szczęk	Typ uchwytu	Zakres mocowania	Max. wysięg szczęk	Typ uchwytu	Zakres mocowania	Max. wysięg szczęk	Typ uchwytu	Zakres mocowania	Max. wysięg szczęk	Typ uchwytu	Zakres mocowania	Max. wysięg szczęk	Typ uchwytu
	Диапазон зажима	Макс. вылет кулачков	Тип патрона	Диапазон зажима	Макс. вылет кулачков	Тип патрона	Диапазон зажима	Макс. вылет кулачков	Тип патрона	Диапазон зажима	Макс. вылет кулачков	Тип патрона	Диапазон зажима	Макс. вылет кулачков	Тип патрона
	34 - 66 33 - 64	182 187	TP 160; RORA TP 160 ROTA NCK plus 165							30 - 53 33 - 50 33 - 55 37 - 61 30 - 55	176 171 177 183 176	GHDN/GHD-FC 165 AN-D/BH-D 165 AL-D 165 BB-D 175 HFKN-D 165			
	56 - 83 48 - 87	185 189	TP 160; RORA TP 160 ROTA NCK plus 165							50 - 76 49 - 72 49 - 78 60 - 85 52 - 77	177 173 179 185 178	GHDN/GHD-FC 165 AN-D/BH-D 165 AL-D 165 BB-D 175 HFKN-D 165			
	82 - 110 74 - 114	186 190	TP 160; RORA TP 160 ROTA NCK plus 165							76 - 102 76 - 99 74 - 99 75 - 105 86 - 111 78 - 104	177 174 174 180 186 179	GHDN/GHD-FC 165 AN-D BH-D 165 AL-D 165 BB-D 175 HFKN-D 165			
	108 - 136 100 - 140	193 198	TP 160; RORA TP 160 ROTA NCK plus 165							102 - 128 101 - 125 100 - 125 100 - 131 112 - 137 104 - 130	185 182 182 188 194 187	GHDN/GHD-FC 165 AN-D BH-D 165 AL-D 165 BB-D 175 HFKN-D 165			
	32 - 62 32 - 66 23 - 67 32 - 73 32 - 79	210 213 216 221 228	HSL 210 ROTA NC/TH 210; ROTA NCF/THF 210 ROTA NCD 210 TP 200; ROTA TP 200 ROTA NCK plus 210	32 - 57 30 - 56 34 - 60 32 - 66 38 - 71	205 210 216 215 219	NH/NHF 200 KG/KS/KT 200 KGH/KGHF 200 QLC/QLK 200 QLC-KS/QLK-KS 200	32 - 57 31 - 57	205 205	KFD 200; KFD-HF 200 KFH 200	30 - 66 30 - 60 30 - 70 32 - 63 32 - 71 33 - 65 34 - 78	215 209 220 211 219 213 227	HFV/HFVS 200 KDV/KDVG/KFV/KFMF 200 GHDN/GHD-FC 210 AN-D/BH-D 210 AL-D 210 BB-D 210 HFKN-D 210	30 - 54 30 - 60	204 210	HES/HESF 200; KF 200 KHFF 200
	60 - 92 54 - 96 43 - 95 60 - 100 47 - 107	213 213 216 221 228	HSL 210 ROTA NC/TH 210; ROTA NCF/THF 210 ROTA NCD 210 TP 200; ROTA TP 200 ROTA NCK plus 210	44 - 85 50 - 84 62 - 88 48 - 94 65 - 98	205 208 216 215 219	NH/NHF 200 KG/KS/KT 200 KGH/KGHF 200 QLC/QLK 200 QLC-KS/QLK-KS 200	47 - 85 44 - 85 58 - 85	205 205 205	KFD 200 KFD-HF 200 KFH 200	60 - 92 60 - 88 60 - 100 55 - 90 55 - 90 60 - 92 61 - 106	215 211 220 211 219 213 227	HFV/HFVS/KDV/KDVG 200 KFV/KFMF 200 GHDN/GHD-FC 210 AN-D/BH-D 210 AL-D 210 BB-D 210 HFKN-D 210	50 - 84 50 - 90	204 210	HES/HESF 200; KF 200 KHFF 200
	88 - 121 82 - 124 70 - 123 88 - 129 75 - 136	212 212 215 220 231	HSL 210 ROTA NC/TH 210; ROTA NCF/THF 210 ROTA NCD 210 TP 200; ROTA TP 200 ROTA NCK plus 210	72 - 113 80 - 113 91 - 117 76 - 123 94 - 127	204 207 214 214 218	NH/NHF 200 KG/KS/KT 200 KGH/KGHF 200 QLC/QLK 200 QLC-KS/QLK-KS 200	75 - 113 72 - 113 86 - 113	204 204 204	KFD 200 KFD-HF 200 KFH 200	80 - 119 88 - 117 85 - 127 83 - 119 83 - 127 88 - 121 89 - 135	212 208 217 210 218 212 226	HFV/HFVS/KDV/KDVG 200 KFV/KFMF 200 GHDN/GHD-FC 210 AN-D/BH-D 210 AL-D 210 BB-D 210 HFKN-D 210	80 - 111 80 - 117	201 210	HES/HESF 200; KF 200 KHFF 200
	117 - 150 111 - 153 99 - 152 116 - 158 103 - 164	216 216 219 224 231	HSL 210 ROTA NC/TH 210; ROTA NCF/THF 210 ROTA NCD 210 TP 200; ROTA TP 200 ROTA NCK plus 210	100 - 142 110 - 142 120 - 146 104 - 152 123 - 156	208 211 217 218 222	NH/NHF 200 KG/KS/KT 200 KGH/KGHF 200 QLC/QLK 200 QLC-KS/QLK-KS 200	103 - 142 100 - 142 115 - 142	208 208 208	KFD 200 KFD-HF 200 KFH 200	110 - 152 110 - 148 114 - 146 114 - 156 112 - 148 112 - 156 117 - 150 118 - 163	217 213 212 221 214 222 216 230	HFV/HFVS 200 KDV/KDVG 200 KFV/KFMF 200 GHDN/GHD-FC 210 AN-D/BH-D 210 AL-D 210 BB-D 210 HFKN-D 210	110 - 140 110 - 146	205 211	HES/HESF 200; KF 200 KHFF 200
	148 - 181 142 - 184 129 - 183 147 - 188 133 - 195	241 240 243 248 255	HSL 210 ROTA NC/TH 210; ROTA NCF/THF 210 ROTA NCD 210 TP 200; ROTA TP 200 ROTA NCK plus 210	130 - 172 140 - 171 149 - 175 134 - 182 153 - 186	232 245 252 242 246	NH/NHF 200 KG/KS/KT 200 KGH/KGHF 200 QLC/QLK 200 QLC-KS/QLK-KS 200	134 - 172 130 - 172 145 - 172	232 232 232	KFD 200 KFD-HF 200 KFH 200	140 - 181 140 - 176 144 - 185 142 - 178 142 - 186 147 - 180 148 - 194	251 247 255 238 246 240 254	HFV/HFVS 200 KDV/KDVG/KFV/KFMF 200 GHDN/GHD-FC 210 AN-D/BH-D 210 AL-D 210 BB-D 210 HFKN-D 210	140 - 169 140 - 175	239 245	HES/HESF 200; KF 200 KHFF 200

- 1
- 2
- 3
- 4
- 5
- 6

7

Distrybucja: unihurt.pl



Zamówienia: info@unihurt.pl KMS

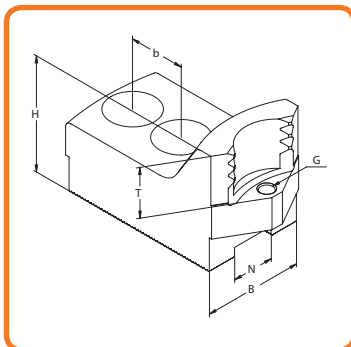

**SZCZĘKI CHWYTAKOWE - MOCOWANIE WEWNĘTRZNE**  
КУЛАЧКИ ЗУБЧАТЫЕ - ВНУТРЕННИЙ ЗАЖИМ

**CAŁOWA WIELKOŚĆ KĄTA ZĄBKÓW 1/16" x 90°**  
ДЮЙМОВОЕ ЗУБЧАТОЕ СОЕДИНЕНИЕ 1/16" x 90°

- Możliwość regulacji głębokości mocowania przedmiotu obrabianego „T”, za pomocą wymiennych kołków опорowych.
- Śruby nie wchodzą w zakres dostawy i muszą być zamawiane oddzielnie.
- Возможность регулировки глубины крепления обрабатываемой детали «Т» при помощи съемных опорных шпилек.
- Эти шпильки не входят в комплект поставки и должны быть заказаны отдельно.

Nr produktu	Typ szczęk	N	B	H	T	G	b	Śruby	kg / kpl.
								Винты	кг / кпл.
398522732400	SWKB C250-17-06	17	35	55	25	M 6	22	M 12	2,1
398522733700	SWKB C250-17-07	17	35	55	25	M 6	22	M 12	1,7
398522734000	SWKB C250-17-08	17	40	55	25	M 6	22	M 12	1,7
398522735200	SWKB C250-17-09	17	40	55	25	M 6	22	M 12	2,2
398522736500	SWKB C250-21-37	21	50	58	25	M 8	28	M 16	3,4
398522737800	SWKB C250-21-38	21	50	58	25	M 8	28	M 16	2,7
398522738000	SWKB C250-21-39	21	50	58	25	M 8	28	M 16	2,5
398522739300	SWKB C250-21-40	21	50	58	25	M 8	28	M 16	3,1
398522727600	SWKB C250-16-50	16	45	60	22	M 6	29	M 16	3,5
398522728900	SWKB C250-16-51	16	45	60	22	M 6	29	M 16	2,9
398522729100	SWKB C250-16-52	16	45	60	22	M 6	29	M 16	2,4
398522730900	SWKB C250-16-53	16	45	60	22	M 6	29	M 16	2,3
398522731100	SWKB C250-16-54	16	45	60	22	M 6	29	M 16	2,7

Ø 250 mm

**Kołki опорowe** str. 503  
Опорные шпильки стр.

**Wkładki teowe** str. 492-501  
Т-образные вкладки стр.

Dystrybucja: unihurt.pl  
Zamówienia: info@unihurt.pl



Zamówienia: info@unihurt.pl

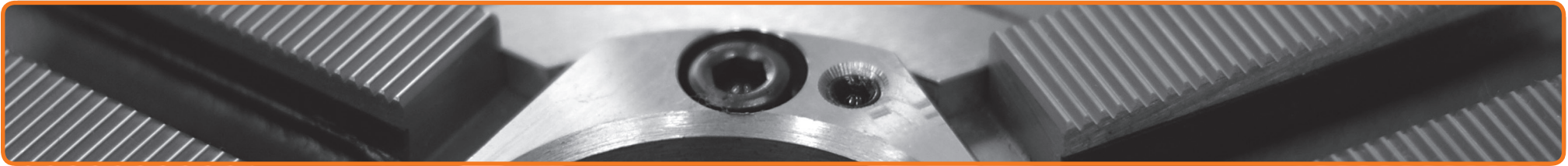

Ø 250 mm	SCHUNK			FORKARDT			RÖHM			SMW-AUTOBLOK			BERG		
	Zakres mocowania	Max. wysięg szczęk	Typ uchwytu	Zakres mocowania	Max. wysięg szczęk	Typ uchwytu	Zakres mocowania	Max. wysięg szczęk	Typ uchwytu	Zakres mocowania	Max. wysięg szczęk	Typ uchwytu	Zakres mocowania	Max. wysięg szczęk	Typ uchwytu
	Диапазон зажима	Макс. вылет кулачков	Тип патрона	Диапазон зажима	Макс. вылет кулачков	Тип патрона	Диапазон зажима	Макс. вылет кулачков	Тип патрона	Диапазон зажима	Макс. вылет кулачков	Тип патрона	Диапазон зажима	Макс. вылет кулачков	Тип патрона
	58 - 89	260	HSG 250	40 - 82	261	NFH 250-65 (Index)	35 - 84	274	KFD-HS 250; KFL 250						
	52 - 118	274	ROTA NCK plus 250	40 - 82	261	KL/KS 250 (Monforts)									
	89 - 138	259	HSG 250	70 - 133	262	NFH 250-65 (Index)	70 - 133	255	KFD-HS 250						
	68 - 133	255	ROTA NCK plus 250	70 - 133	262	KL/KS 250 (Monforts)	68 - 133	255	KFL 250						
	148 - 196	266	HSG 250	130 - 192	270	NFH 250-65 (Index)	130 - 192	262	KFD-HS 250						
	126 - 192	262	ROTA NCK plus 250	130 - 192	270	KL/KS 250 (Monforts)	126 - 192	262	KFL 250						
	182 - 231	301	HSG 250	160 - 227	305	NFH 250-65 (Index)	164 - 227	297	KFD-HS 250						
	160 - 227	297	ROTA NCK plus 250	160 - 227	305	KL/KS 250 (Monforts)	160 - 227	297	KFL 250						
	49 - 93	264	HSL 250	41 - 83	251	NH/NHF 250	49 - 90	258	KFD 250	53 - 99	264	HFV/HFVKS 250	43 - 88	253	HES 250; HESF 250; KHFF 250
	47 - 95	264	ROTA NC/TH 250; ROTA NCF/THF 250	40 - 89	260	KG/KL/KT 250	46 - 90	258	KFD-HF 250; KFH 250	48 - 94	262	KFV/KFMF 250	40 - 85	250	KF 250
	40 - 104	273	ROTA NCD 250	40 - 89	260	KTGF/KTN 250				45 - 98	263	GHDN/GHD-FC 250			
	54 - 110	279	TP 250; ROTA TP 250	43 - 97	265	QLC/QLK 250				48 - 89	258	AN-D/BH-D 250			
										48 - 100	268	AL-D 250			
										57 - 90	258	BB-D 250			
										40 - 90	258	HFKN-D 260			
										56 - 88	267	BHD-FC 250			
	88 - 133	261	HSL 250	69 - 123	251	NH/NHF 250	82 - 130	258	KFD 250	91 - 138	266	HFV/HFVKS 250	81 - 127	255	HES 250; HESF 250; KHFF 250
	86 - 135	264	ROTA NC/TH 250; ROTA NCF/THF 250	76 - 128	262	KG/KL/KT 250	88 - 130	258	KFD-HF 250; KFH 250	88 - 134	263	KFV/KFMF 250	76 - 124	252	KF 250
	80 - 144	273	ROTA NCD 250	76 - 128	262	KTGF/KTN 250				83 - 137	265	GHDN/GHD-FC 250			
	94 - 150	279	TP 250; ROTA TP 250	82 - 137	265	QLC/QLK 250				87 - 130	258	AN-D/BH-D 250			
										87 - 140	268	AL-D 250			
										97 - 130	258	BB-D 250			
										79 - 130	258	HFKN-D 260			
										95 - 128	257	BHD-FC 250			
	138 - 182	269	HSL 250	118 - 173	253	NH/NHF 250	131 - 179	260	KFD 250	138 - 188	268	HFV/HFVKS 250	128 - 177	257	HES 250; HESF 250; KHFF 250
	136 - 184	266	ROTA NC/TH 250; ROTA NCF/THF 250	125 - 178	264	KG/KL/KT 250	134 - 179	260	KFD-HF 250	135 - 183	265	KFV/KFMF 250	124 - 174	254	KF 250
	129 - 193	273	ROTA NCD 250	125 - 178	264	KTGF/KTN 250	135 - 179	260	KFH 250	132 - 187	267	GHDN/GHD-FC 250			
	144 - 200	281	TP 250; ROTA TP 250	131 - 186	267	QLC/QLK 250				137 - 179	260	AN-D/BH-D 250			
										137 - 189	270	AL-D 250			
										146 - 179	260	BB-D 250			
										128 - 179	260	HFKN-D 260			
										145 - 177	259	BHD-FC 250			
	182 - 229	300	HSL 250	164 - 220	290	NH/NHF 250	178 - 226	297	KFD 250	187 - 235	305	HFV/HFVKS 250	176 - 224	294	HES 250; HESF 250; KHFF 250
	182 - 231	303	ROTA NC/TH 250; ROTA NCF/THF 250	170 - 225	301	KG/KL/KT 250	181 - 226	297	KFD-HF 250; KFH 250	183 - 230	303	KFV/KFMF 250	168 - 221	291	KF 250
	174 - 241	312	ROTA NCD 250	170 - 225	301	KTGF/KTN 250				180 - 234	304	GHDN/GHD-FC 250			
	190 - 247	318	TP 250; ROTA TP 250	178 - 233	304	QLC/QLK 250				183 - 226	297	AN-D/BH-D 250			
										183 - 236	307	AL-D 250			
										193 - 226	297	BB-D 250			
										174 - 226	297	HFKN-D 260			
										191 - 225	297	BHD-FC 250			
													50 - 100	320	KH 250
													50 - 164	384	KH 315
													92 - 126	266	KH 250
													118 - 186	326	KH 315
													126 - 160	266	KH 250
													148 - 216	322	KH 315
													160 - 194	266	KH 250
													189 - 154	326	KH 315
													194 - 228	286	KH 250
													220 - 288	346	KH 315

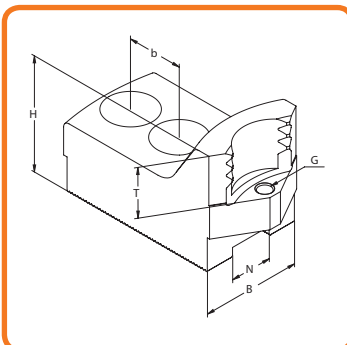

**SZCZĘKI CHWYTAKOWE - MOCOWANIE WEWNĘTRZNE**  
 КУЛАЧКИ ЗУБЧАТЫЕ - ВНУТРЕННИЙ ЗАЖИМ

**CAŁOWA WIELKOŚĆ KĄTA ZĄBKÓW 1/16" x 90°**  
 ДЮЙМОВОЕ ЗУБЧАТОЕ СОЕДИНЕНИЕ 1/16" x 90°

- Możliwość regulacji głębokości mocowania przedmiotu obrabianego „T”, za pomocą wymiennych kołków опорowych.
- Śruby nie wchodzą w zakres dostawy i muszą być zamawiane oddzielnie.
- Возможность регулировки глубины крепления обрабатываемой детали «Т» при помощи съемных опорных шпилек.
- Эти шпильки не входят в комплект поставки и должны быть заказаны отдельно.

Nr produktu	Typ szczęk	N	B	H	T	G	b	Śruby		kg / kpl.
								Код продукта	Тип кулачков	
398522740000	SWKB C315-21-10	21	50	58	25	M 8	28	M 16		4,3
398522741300	SWKB C315-21-11	21	50	58	25	M 8	28	M 16		3,3
398522742600	SWKB C315-21-12	21	50	58	25	M 8	28	M 16		2,9
398522743900	SWKB C315-21-13	21	50	58	25	M 8	28	M 16		3,9
398522740000	SWKB C315-21-10	21	50	58	25	M 8	28	M 16		4,3
398522741300	SWKB C315-21-11	21	50	58	25	M 8	28	M 16		3,3
398522742600	SWKB C315-21-12	21	50	58	25	M 8	28	M 16		2,9
398522743900	SWKB C315-21-13	21	50	58	25	M 8	28	M 16		3,9

Ø 315 mm

**Kołki опорowe** str. 503  
 Опорные шпильки стр.

**Wkładki teowe** str. 492-501  
 Т-образные вкладки стр.

Dystrybucja: unihurt.pl  
 Zamówienia: info@unihurt.pl



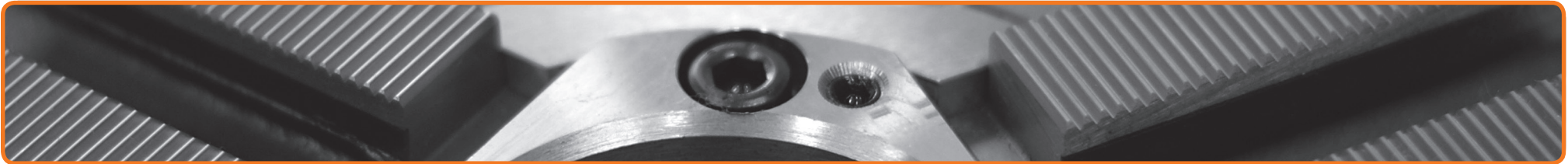

Ø 315 mm	SCHUNK			FORKARDT			RÖHM			SMW-AUTOBLOK			BERG		
	Zakres mocowania	Max. wysięg szczęk	Typ uchwytu	Zakres mocowania	Max. wysięg szczęk	Typ uchwytu	Zakres mocowania	Max. wysięg szczęk	Typ uchwytu	Zakres mocowania	Max. wysięg szczęk	Typ uchwytu	Zakres mocowania	Max. wysięg szczęk	Typ uchwytu
	Диапазон зажима	Макс. вылет кулачков	Тип патрона	Диапазон зажима	Макс. вылет кулачков	Тип патрона	Диапазон зажима	Макс. вылет кулачков	Тип патрона	Диапазон зажима	Макс. вылет кулачков	Тип патрона	Диапазон зажима	Макс. вылет кулачков	Тип патрона
63 - 130	330	HSG 315		47 - 131	332	NH/NHF 315	50 - 117	316	KFD 315	50 - 122	321	HFH/HFKS 315	50 - 113	312	HES 315; HESF 315
54 - 136	337	HSL 315		50 - 112	318	KG/KS/KT 315	50 - 119	318	KFD-HF 315	50 - 125	324	KFMF 315	50 - 110	309	KF 315
51 - 132	333	ROTA NC/TH 315; ROTA NCF/THF 315		47 - 136	337	QLC/QLK 315	47 - 118	317	KFD-HS 315	47 - 138	339	AL-D 315	50 - 115	314	KHFF 315
49 - 137	338	ROTA NCD 315		50 - 146	353	NHF 400 S 12	46 - 119	318	KFH 315	47 - 126	327	AN-D 315			
59 - 151	353	TP 315; ROTA TP 315		50 - 146	353	KS/KSH/KSHF 400	47 - 117	316	KFL 315	82 - 125	326	BB-D 315			
46 - 135	336	ROTA NCK plus 315								52 - 126	327	BH-D 315			
										68 - 168	339	HFKN-D 315			
										56 - 122	322	BHD-FC 315			
120 - 187	331	HSG 315		93 - 189	345	NH/NHF 315	100 - 176	320	KFD 315	100 - 181	325	HFH/HFKS 315	110 - 172	316	HES 315; HESF 315
113 - 187	354	HSL 315		100 - 171	322	KG/KS/KT 315	107 - 178	322	KFD-HF 315	105 - 185	329	KFMF 315	100 - 169	313	KF 315
107 - 189	346	ROTA NC/TH 315; ROTA NCF/THF 315		92 - 194	350	QLC/QLK 315	100 - 177	321	KFD-HS 315	96 - 196	352	AL-D 315	100 - 174	318	KHFF 315
105 - 195	351	ROTA NCD 315		110 - 255	407	NHF 400 S 12	104 - 178	322	KFH 315	96 - 184	340	AN-D 315			
111 - 209	366	TP 315; ROTA TP 315		110 - 255	407	KS/KSH/KSHF 400	100 - 176	320	KFL 315	140 - 183	339	BB-D 315			
104 - 192	349	ROTA NCK plus 315								110 - 184	340	BH-D 315			
										126 - 196	352	HFKN-D 315			
										117 - 183	340	BHD-FC 315			
187 - 253	330	HSG 315		157 - 255	331	NH/NHF 315	170 - 242	318	KFD 315	165 - 247	323	HFH/HFKS 315	172 - 238	314	HES 315; HESF 315
178 - 263	340	HSL 315		160 - 237	320	KG/KS/KT 315	170 - 244	320	KFD-HF 315	175 - 248	322	KFMF 315	168 - 235	311	KF 315
174 - 255	332	ROTA NC/TH 315; ROTA NCF/THF 315		156 - 260	336	QLC/QLK 315	170 - 243	319	KFD-HS 315	161 - 262	338	AL-D 315	168 - 240	316	KHFF 315
171 - 261	337	ROTA NCD 315					169 - 244	320	KFH 315	160 - 250	326	AN-D 315			
176 - 275	352	TP 315; ROTA TP 315					170 - 242	318	KFL 315	205 - 249	325	BB-D 315			
169 - 258	335	ROTA NCK plus 315								175 - 250	326	BH-D 315			
										191 - 262	338	HFKN-D 315			
										183 - 250	326	BHD-FC 315			
251 - 317	389	HSG 315		221 - 319	391	NH/NHF 315	220 - 294	366	KFD 315	228 - 299	371	HFH/HFKS 315	234 - 290	362	HES 315; HESF 315
242 - 315	388	HSL 315		220 - 290	368	KG/KS/KT 315	226 - 296	368	KFD-HF 315	235 - 300	372	KFMF 315	220 - 287	359	KF 315
237 - 315	388	ROTA NC/TH 315; ROTA NCF/THF 315		220 - 324	396	QLC/QLK 315	222 - 295	367	KFD-HS 315	225 - 326	398	AL-D 315	220 - 292	364	KHFF 315
233 - 315	387	ROTA NCD 315		237 - 375	453	NHF 400 S 12	233 - 296	368	KFH 315	224 - 314	386	AN-D 315			
241 - 315	390	TP 315; ROTA TP 315		237 - 375	453	KS/KSH/KSHF 400	222 - 294	366	KFL 315	269 - 313	385	BB-D 315			
233 - 315	395	ROTA NCK plus 315								240 - 314	386	BH-D 315			
										255 - 315	387	HFKN-D 315			
										248 - 313	385	BHD-FC 315			
							50 - 146	345	KFL 400	95 - 216	408	BHD-FC 400			
							100 - 255	399	KFL 400	152 - 274	416	BHD-FC 400			
										219 - 340	410	BHD-FC 400			
							222 - 373	445	KFL 400	283 - 390	462	BHD-FC 400			

- 1
- 2
- 3
- 4
- 5
- 6

7

Distybuycja: unihurt.pl



Zamówienia: info@unihurt.pl | KMS



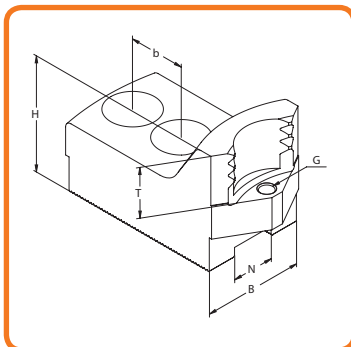

**SZCZĘKI CHWYTAKOWE - MOCOWANIE WEWNĘTRZNE**  
 КУЛАЧКИ ЗУБЧАТЫЕ - ВНУТРЕННИЙ ЗАЖИМ

**CAŁOWA WIELKOŚĆ KĄTA ZĄBKÓW 3/32" x 90°**  
 ДЮЙМОВОЕ ЗУБЧАТОЕ СОЕДИНЕНИЕ 3/32" x 90°

- Możliwość regulacji głębokości mocowania przedmiotu obrabianego „T”, za pomocą wymiennych kołków опорowych.
- Śruby nie wchodzą w zakres dostawy i muszą być zamawiane oddzielnie.
- Возможность регулировки глубины крепления обрабатываемой детали «Т» при помощи съемных опорных шпилек.
- Эти шпильки не входят в комплект поставки и должны быть заказаны отдельно.

Nr produktu	Typ szczęk	N	B	H	T	G	b	Śruby	kg / kpl.
								Винты	кг / кпл.
398522744100	SWKB C400-25,5-11	25,5	60	78	33	M 8	35	M 20	8,1
398522746700	SWKB C400-25,5-13	25,5	60	78	33	M 8	35	M 20	6,9
398522747000	SWKB C400-25,5-14	25,5	60	78	33	M 8	35	M 20	6,0
398522748200	SWKB C400-25,5-15	25,5	60	78	33	M 8	35	M 20	7,1
398522745400	SWKB C400-25,5-12	25,5	60	78	33	M 8	35	M 20	9,9
398522746700	SWKB C400-25,5-13	25,5	60	78	33	M 8	35	M 20	6,9
398522747000	SWKB C400-25,5-14	25,5	60	78	33	M 8	35	M 20	6
398522748200	SWKB C400-25,5-15	25,5	60	78	33	M 8	35	M 20	7,1
398522749500	SWKB C400-25,5-16	25,5	60	78	33	M 8	35	M 20	7,1

**Kołki опорowe** str. 503  
 Опорные шпильки стр.

**Wkładki teowe** str. 492-501  
 Т-образные вкладки стр.

Dystrybucja: unihurt.pl  
 Zamówienia: info@unihurt.pl

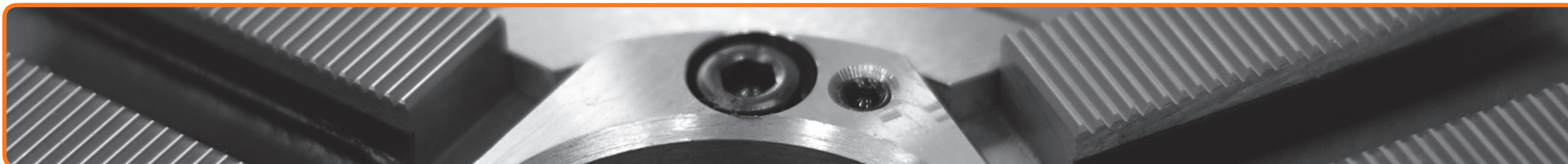

Ø 400 mm	SCHUNK			FORKARDT			RÖHM			SMW-AUTOBLOK			BERG		
	Zakres mocowania	Max. wysięg szczęk	Typ uchwytu	Zakres mocowania	Max. wysięg szczęk	Typ uchwytu	Zakres mocowania	Max. wysięg szczęk	Typ uchwytu	Zakres mocowania	Max. wysięg szczęk	Typ uchwytu	Zakres mocowania	Max. wysięg szczęk	Typ uchwytu
	Диапазон зажима	Макс. вылет кулачков	Тип патрона	Диапазон зажима	Макс. вылет кулачков	Тип патрона	Диапазон зажима	Макс. вылет кулачков	Тип патрона	Диапазон зажима	Макс. вылет кулачков	Тип патрона	Диапазон зажима	Макс. вылет кулачков	Тип патрона
	65 - 165	429	HSG 400	57 - 158	422	NH/NHF 400	70 - 156	420	KFD 400	75 - 187	452	HFH/HFKS 400	70 - 150	414	HES 400; KF 400; KHFF 400
	86 - 158	440	HSL 400	70 - 150	414	KG/KL 400; KT/KTGF 400	70 - 156	420	KFD-HF 400	74 - 166	434	AL-D 400; AN-D 400			
	75 - 157	438	ROTA NC/TH 400; ROTA NCF/THF 400	60 - 156	420	QLC/QLK 400	67 - 156	420	KFD-HS 400	71 - 187	452	HFKN-D 400			
	60 - 161	426	ROTA NCD 400				70 - 156	420	KFH 400	73 - 156	420	BH-D 400			
										73 - 215	480	BH-D 450			
	140 - 220	445	HSG 400	126 - 233	452	NH/NHF 400	150 - 231	456	KFD 400	150 - 263	488	HFH/HFKS 400	150 - 230	454	HES 400; KF 400; KHFF 400
	158 - 233	455	HSL 400	150 - 230	454	KG/KL 400; KT/KTGF 400	150 - 231	456	KFD-HF 400	150 - 241	470	AL-D 400; AN-D 400			
	148 - 248	474	ROTA NC/TH 400; ROTA NCF/THF 400	134 - 231	456	QLC/QLK 400	150 - 231	456	KFD-HS 400	145 - 263	488	HFKN-D 400			
	134 - 236	462	ROTA NCD 400				148 - 231	456	KFH 400	148 - 231	456	BH-D 400			
										148 - 291	516	BH-D 450			
	225 - 325	446	HSG 400	209 - 317	438	NH/NHF 400	224 - 315	436	KFD 400	234 - 347	468	HFH/HFKS 400	230 - 310	430	HES 400; KF 400; KHFF 400
	241 - 317	438	HSL 400	230 - 310	430	KG/KL 400; KT/KTGF 400	221 - 315	436	KFD-HF 400	235 - 325	450	AL-D 400; AN-D 400			
	232 - 317	454	ROTA NC/TH 400; ROTA NCF/THF 400	217 - 315	436	QLC/QLK 400	225 - 315	436	KFD-HS 400	229 - 347	468	HFKN-D 400			
	217 - 321	442	ROTA NCD 400				226 - 315	436	KFH 400	232 - 315	436	BH-D 400			
										232 - 375	496	BH-D 450			
	295 - 295	486	HSG 400	279 - 388	479	NH/NHF 400	279 - 386	477	KFD 400	304 - 400	491	HFH/HFKS 400	310 - 380	470	HES 400; KF 400; KHFF 400
	314 - 383	479	HSL 400	310 - 380	470	KG/KL 400; KT/KTGF 400	291 - 386	477	KFD-HF 400	303 - 396	491	AL-D 400; AN-D 400			
	299 - 388	495	ROTA NC/TH 400; ROTA NCF/THF 400	287 - 386	477	QLC/QLK 400	295 - 386	477	KFD-HS 400	299 - 400	491	HFKN-D 400			
	297 - 391	483	ROTA NCD 400				287 - 386	477	KFH 400	302 - 386	477	BH-D 400			
										302 - 446	597	BH-D 450			
	86 - 220	429	HSG 500	74 - 230	572	NH/NHF 500	96 - 220	564	KFD 500	120 - 260	540	HFH/HFKS 500	100 - 200	540	HES 500; KF 500
	108 - 205	587	ROTA NC/TH 500; ROTA NCF/THF 500	74 - 226	568	KS 500	100 - 206	548	KFH 500	100 - 250	540	HFKN-D 500	100 - 200	540	HES 630; KF 630
	74 - 234	577	ROTA NCD 500	100 - 200	540	KT/KTGF 630	100 - 220	562	KFD-HF 500	111 - 245	587	BH-D 500			
				90 - 260	620	NH/NHF 630	100 - 220	568	KFD-HS 500						
	186 - 320	445	HSG 500	165 - 330	556	NH/NHF 500	200 - 300	524	KFD 500	191 - 342	568	HFH/HFKS 500	200 - 300	524	HES 500; KF 500
	206 - 345	571	ROTA NC/TH 500; ROTA NCF/THF 500	184 - 326	552	KS 500	190 - 310	534	KFH 500	175 - 340	524	HFKN-D 500	200 - 300	524	HES 630; KF 630
	133 - 334	561	ROTA NCD 500	200 - 300	524	KT/KTGF 630	195 - 315	540	KFD-HF 500	270 - 345	571	BH-D 500			
				190 - 400	626	NH/NHF 630	190 - 310	535	KFD-HS 500						
	270 - 425	446	HSG 500	248 - 414	536	NH/NHF 500	270 - 380	528	KFD 500	275 - 426	548	HFH/HFKS 500	300 - 380	500	HES 500; KF 500
	290 - 429	551	ROTA NC/TH 500; ROTA NCF/THF 500	265 - 385	517	KS 500	300 - 390	526	KFH 500	260 - 425	548	HFKN-D 500	300 - 380	500	HES 630; KF 630
	216 - 419	541	ROTA NCD 500	300 - 380	500	KT/KTGF 630	270 - 390	526	KFD-HF 500	294 - 429	551	BH-D 500			
				275 - 510	632	NH/NHF 630	270 - 390	526	KFD-HS 500						
	340 - 495	486	HSG 500	319 - 450	540	NH/NHF 500	350 - 430	520	KFD 500	346 - 498	520	HFH/HFKS 500	350 - 430	520	HES 500; KF 500
	360 - 500	592	ROTA NC/TH 500; ROTA NCF/THF 500	249 - 450	520	KS 500	340 - 430	520	KFH 500	330 - 495	589	HFKN-D 500	350 - 450	540	HES 630; KF 630
	286 - 490	582	ROTA NCD 500	350 - 430	520	KT/KTGF 630	340 - 440	530	KFD-HF 500	365 - 501	592	BH-D 500			
				345 - 615	707	NH/NHF 630	340 - 435	535	KFD-HS 500						
	440 - 500	637	ROTA NC/TH 500; ROTA NCF/THF 500	398 - 565	596	NH/NHF 500	420 - 500	596	KFD 500				430 - 500	596	HES 500; KF 500
	366 - 500	633	ROTA NCD 500	329 - 500	596	KS 500	400 - 500	596	KFH 500				450 - 560	656	HES 630; KF 630
				430 - 560	656	KT/KTGF 630	420 - 500	596	KFD-HF 500						
							420 - 500	596	KFD-HS 500						

1  
2  
3  
4  
5  
6  
7  
Dystrybucja: unihurt.pl  
Zamówienia: info@unihurt.pl  
SWK

1  
2  
3  
4  
5  
6  
7  
C

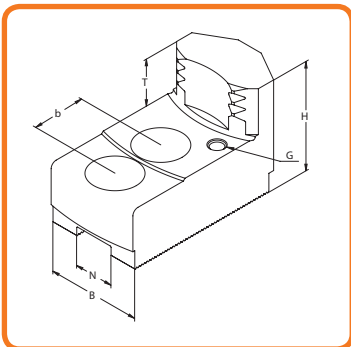

**SZCZĘKI CHWYTAKOWE - MOCOWANIE ZEWNĘTRZNE**  
 КУЛАЧКИ ЗУБЧАТЫЕ - ВНЕШНИЙ ЗАЖИМ

**CAŁOWA WIELKOŚĆ KĄTA ZĄBKÓW 1/16" x 90°**  
 ДЮЙМОВОЕ ЗУБЧАТОЕ СОЕДИНЕНИЕ 1/16" x 90°



- Możliwość regulacji głębokości mocowania przedmiotu obrabianego „T”, za pomocą wymiennych kołków опорowych.
- Śruby nie wchodzą w zakres dostawy i muszą być zamawiane oddzielnie.
- Возможность регулировки глубины крепления обрабатываемой детали «Т» при помощи съемных опорных шпилек.
- Эти шпильки не входят в комплект поставки и должны быть заказаны отдельно.

Nr produktu	Typ szczęk	N	B	H	T	G	b	Śruby		kg / kpl.
								Винты	кг / кпл.	
398522600200	SZKB C200-17-10	17	35	50	20	M 6	22	M 12	1,6	
398522601500	SZKB C200-17-11	17	40	50	20	M 6	22	M 12	1,8	
398522602800	SZKB C200-17-12	17	40	50	20	M 6	22	M 12	1,5	

Ø 200 mm

**Kołki опорowe** str. 503  
 Опорные шпильки стр.

**Wkładki teowe** str. 492-501  
 Т-образные вкладки стр.

Dystrybucja: unihurt.pl  
 Zamówienia: info@unihurt.pl

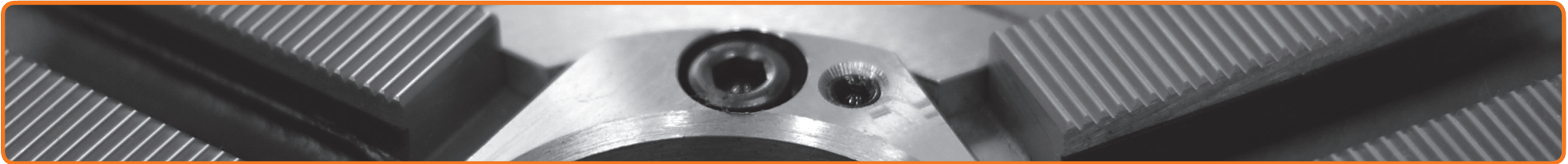

Zakres mocowania	SCHUNK			FORKARDT			RÖHM			SMW-AUTOBLOK			BERG		
	Max. wysięg szczęk	Typ uchwytu		Max. wysięg szczęk	Typ uchwytu		Max. wysięg szczęk	Typ uchwytu		Max. wysięg szczęk	Typ uchwytu		Max. wysięg szczęk	Typ uchwytu	
	Диапазон зажима	Макс. вылет кулачков	Тип патрона	Диапазон зажима	Макс. вылет кулачков	Тип патрона	Диапазон зажима	Макс. вылет кулачков	Тип патрона	Диапазон зажима	Макс. вылет кулачков	Тип патрона	Диапазон зажима	Макс. вылет кулачков	Тип патрона
Ø 200 mm	69 - 102	215	HSL 210	62 - 93	206	NH/NHF 200	62 - 93	206	KFD 200	60 - 103	215	HFH/HFKS 200	60 - 91	203	HES/HESF 200; KF 200
	61 - 103	216	ROTA NC/TH 210; ROTA NCF/THF 210	60 - 93	209	KG/KS/KT 200	62 - 93	206	KFD-HF 200	62 - 95	208	KFMF/KFV 200	60 - 97	209	KHFF 200
	62 - 104	217	ROTA NCD 210	73 - 97	210	KGH/KGHF 200	66 - 93	206	KFH 200	60 - 107	219	GHDN/GHD-FC 210			
	68 - 109	222	TP 200; ROTA TP 200	62 - 103	216	QLC/QLK 200				63 - 99	212	AL-D/AN-D 210			
	62 - 106	220	ROTA NCK plus 210							68 - 101	214	BB-D 210			
										62 - 100	213	BH-D 210			
										72 - 110	218	HFKN-D 210			
	97 - 130	215	HSL 210	81 - 122	206	NH/NHF 200	84 - 122	206	KFD 200	88 - 131	215	HFH/HFKS 200	88 - 115	203	HES/HESF 200; KF 200
	91 - 136	216	ROTA NC/TH 210; ROTA NCF/THF 210	88 - 121	209	KG/KS/KT 200	81 - 122	206	KFD-HF 200	90 - 122	208	KFMF/KFV 200	88 - 121	209	KHFF 200
	79 - 132	217	ROTA NCD 210	99 - 125	210	KGH/KGHF 200	94 - 122	206	KFH 200	88 - 131	215	GHDN/GHD-FC 210			
	96 - 137	222	TP 200; ROTA TP 200	84 - 131	216	QLC/QLK 200				92 - 127	212	AL-D/AN-D 210			
	84 - 135	220	ROTA NCK plus 210							97 - 130	214	BB-D 210			
										82 - 128	213	BH-D 210			
										92 - 138	218	HFKN-D 210			
	129 - 167	215	HSL 210	112 - 153	206	NH/NHF 200	120 - 153	206	KFD 200	120 - 163	215	HFH/HFKS 200	115 - 151	203	HES/HESF 200; KF 200
	121 - 165	216	ROTA NC/TH 210; ROTA NCF/THF 210	120 - 153	209	KG/KS/KT 200	120 - 153	206	KFD-HF 200	122 - 154	208	KFMF/KFV 200	120 - 157	209	KHFF 200
	110 - 163	217	ROTA NCD 210	130 - 157	210	KGH/KGHF 200	121 - 153	206	KFH 200	120 - 167	219	GHDN/GHD-FC 210			
	127 - 168	222	TP 200; ROTA TP 200	115 - 163	216	QLC/QLK 200				123 - 159	212	AL-D/AN-D 210			
	115 - 166	220	ROTA NCK plus 210							128 - 161	214	BB-D 210			
										113 - 160	213	BH-D 210			
									123 - 170	218	HFKN-D 210				

- 1
- 2
- 3
- 4
- 5
- 6
- 7
- C

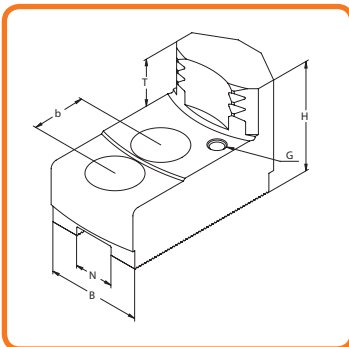

**SZCZĘKI CHWYTAKOWE - MOCOWANIE ZEWNĘTRZNE**  
 КУЛАЧКИ ЗУБЧАТЫЕ - ВНЕШНИЙ ЗАЖИМ

**CALOWA WIELKOŚĆ KĄTA ZĄBKÓW 1/16" x 90°**  
 ДЮЙМОВОЕ ЗУБЧАТОЕ СОЕДИНЕНИЕ 1/16" x 90°



- Możliwość regulacji głębokości mocowania przedmiotu obrabianego „T”, za pomocą wymiennych kołków опорowych.
- Śruby nie wchodzą w zakres dostawy i muszą być zamawiane oddzielnie.
- Возможность регулировки глубины крепления обрабатываемой детали «Т» при помощи съемных опорных шпилек.
- Эти шпильки не входят в комплект поставки и должны быть заказаны отдельно.

Nr produktu	Typ szczęk	N	B	H	T	G	b	Śruby	kg / kpl.
								Винты	кг / кпл.
398522603000	SZKB C250-17-17	17	35	55	25	M 6	22	M 12	1,9
398522604300	SZKB C250-17-18	17	40	55	25	M 6	22	M 12	2,2
398522605600	SZKB C250-17-19	17	40	55	25	M 6	22	M 12	1,9
398522606900	SZKB C250-21-34	21	50	58	25	M 8	28	M 16	3,3
398522607100	SZKB C250-21-35	21	50	58	25	M 8	28	M 16	3,0
398522608400	SZKB C250-21-36	21	50	58	25	M 8	28	M 16	3,0

Ø 250 mm

**Kołki опорowe** str. 503  
 Опорные шпильки стр.

**Wkładki teowe** str. 492-501  
 Т-образные вкладки стр.

Dystrybucja: unihurt.pl  
 Zamówienia: info@unihurt.pl

SZKB C

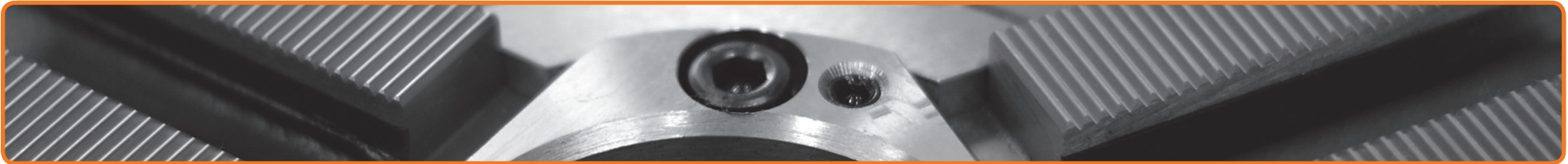

Ø 250 mm	SCHUNK			FORKARDT			RÖHM			SMW-AUTOBLOK			BERG		
	Zakres mocowania	Max. wysięg szczęk	Typ uchwytu	Zakres mocowania	Max. wysięg szczęk	Typ uchwytu	Zakres mocowania	Max. wysięg szczęk	Typ uchwytu	Zakres mocowania	Max. wysięg szczęk	Typ uchwytu	Zakres mocowania	Max. wysięg szczęk	Typ uchwytu
	Диапазон зажима	Макс. вылет кулачков	Тип патрона	Диапазон зажима	Макс. вылет кулачков	Тип патрона	Диапазон зажима	Макс. вылет кулачков	Тип патрона	Диапазон зажима	Макс. вылет кулачков	Тип патрона	Диапазон зажима	Макс. вылет кулачков	Тип патрона
	90 - 133	269	HSG 250	60 - 120	260	NHF 250-65 (Index)	62 - 129	266	KFD-HS 250						
	73 - 143	281	ROTA NCK plus 250	60 - 120	260	KL/KS 250 (Monforts)	63 - 129	266	KFL 250						
	122 - 165	263	HSG 250	106 - 160	266	NHF 250-65 (Index)	106 - 161	260	KFD-HS 250						
	98 - 167	267	ROTA NCK plus 250	106 - 160	266	KL/KS 250 (Monforts)	106 - 161	260	KFL 250						
	185 - 228	273	HSG 250	160 - 223	276	NHF 250-65 (Index)	158 - 225	170	KFD-HS 250						
	161 - 231	277	ROTA NCK plus 250	160 - 223	276	KL/KS 250 (Monforts)	158 - 225	270	KFL 250						
	83 - 121	267	HSL 250	81 - 122	257	NH/NHF 250	81 - 118	264	KFD 250	80 - 128	273	HFJ/HFJS 250	80 - 117	262	HES/HESF 250; KHFF 250
	81 - 121	267	ROTA NC/TH 250; ROTA NCF/THF 250	80 - 118	269	KG/KL/KT 250	81 - 118	264	KFD-HF 250	80 - 120	269	KFV/KFMF 250	80 - 114	259	KF 250
	81 - 132	277	ROTA NCD 250	80 - 188	269	KTGF/KTN 250	81 - 118	264	KFH 250	80 - 126	271	GHDN/GHD-FC 250			
	84 - 139	285	TP 250; ROTA TP 250	81 - 125	271	QLC/QLK 250				77 - 118	264	AL-D/AN-D 250			
										86 - 119	264	BB-D 250			
										81 - 117	263	BH-D 250			
										91 - 127	268	HFKN-D 260			
										81 - 113	264	BHD-FC 250			
	117 - 163	269	HSL 250	105 - 153	259	NH/NHF 250	113 - 160	266	KFD 250	128 - 168	275	HFJ/HFJS 250	117 - 157	264	HES/HESF 250; KHFF 250
	116 - 162	269	ROTA NC/TH 250; ROTA NCF/THF 250	118 - 158	271	KG/KL/KT 250	115 - 160	266	KFD-HF 250	118 - 162	271	KFV/KFMF 250	114 - 154	261	KF 250
	111 - 174	281	ROTA NCD 250	118 - 153	271	KTGF/KTN 250	116 - 160	266	KFH 250	120 - 166	273	GHDN/GHD-FC 250			
	125 - 180	287	TP 250; ROTA TP 250	112 - 167	273	QLC/QLK 250				118 - 160	266	AL-D/AN-D 250			
										127 - 160	266	BB-D 250			
										117 - 159	265	BH-D 250			
										127 - 169	270	HFKN-D 260			
										121 - 153	263	BHD-FC 250			
	164 - 214	275	HSL 250	143 - 199	259	NH/NHF 250	157 - 206	266	KFD 250	168 - 214	275	HFJ/HFJS 250	157 - 203	264	HES/HESF 250; KHFF 250
	160 - 208	269	ROTA NC/TH 250; ROTA NCF/THF 250	158 - 204	271	KG/KL/KT 250	160 - 206	266	KFD-HF 250	162 - 208	271	KFV/KFMF 250	154 - 200	261	KF 250
	155 - 220	281	ROTA NCD 250	158 - 204	271	KTGF/KTN 250	161 - 206	266	KFH 250	166 - 212	273	GHDN/GHD-FC 250			
	170 - 226	287	TP 250; ROTA TP 250	157 - 212	273	QLC/QLK 250				163 - 206	266	AL-D/AN-D 250			
										172 - 206	266	BB-D 250			
										162 - 205	265	BH-D 250			
										172 - 215	270	HFKN-D 260			
										167 - 200	263	BHD-FC 250			

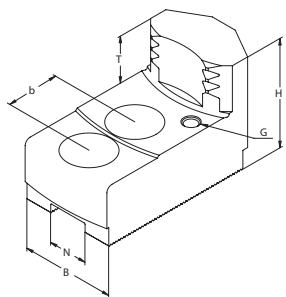

SZCZĘKI CHWYTAKOWE - MOCOWANIE ZEWNĘTRZNE

КУЛАЧКИ ЗУБЧАТЫЕ - ВНЕШНИЙ ЗАЖИМ

CAŁOWA WIELKOŚĆ KĄTA ZĄBKÓW 3/32" x 90°

ДЮЙМОВОЕ ЗУБЧАТОЕ СОЕДИНЕНИЕ 3/32" x 90°



- Możliwość regulacji głębokości mocowania przedmiotu obrabianego „T”, za pomocą wymiennych kołków oporowych.
- Śruby nie wchodzą w zakres dostawy i muszą być zamawiane oddzielnie.
- Возможность регулировки глубины крепления обрабатываемой детали «Т» при помощи съемных опорных шпилек.
- Эти шпильки не входят в комплект поставки и должны быть заказаны отдельно.

Nr produktu	Typ szczęk	N	B	H	T	G	b	Śruby	kg / kpl.
								Винты	кг / кпл.
398522609700	SZKB C315-21-11	21	50	58	25	M 8	28	M 16	4,1
398522610400	SZKB C315-21-12	21	50	58	25	M 8	28	M 16	3,6
398522611700	SZKB C315-21-13	21	50	58	25	M 8	28	M 16	3,2
398522609700	SZKB C315-21-11	21	50	58	25	M 8	28	M 16	4,1
398522611700	SZKB C315-21-13	21	50	58	25	M 8	28	M 16	3,2

Ø 315 mm

Kołki oporowe str. 503  
 Опорные шпильки стр.

Wkładki teowe str. 492-501  
 Т-образные вкладки стр.

Dystrybucja: unihurt.pl  
 Zamówienia: info@unihurt.pl

1  
2  
3  
4  
5  
6  
7  
C

SZKB C



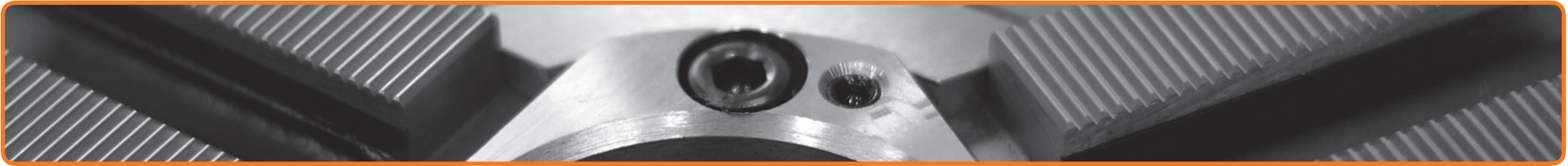

Ø 315 mm	SCHUNK			FORKARDT			RÖHM			SMW-AUTOBLOK			BERG		
	Zakres mocowania	Max. wysięg szczęk	Typ uchwytu	Zakres mocowania	Max. wysięg szczęk	Typ uchwytu	Zakres mocowania	Max. wysięg szczęk	Typ uchwytu	Zakres mocowania	Max. wysięg szczęk	Typ uchwytu	Zakres mocowania	Max. wysięg szczęk	Typ uchwytu
	Диапазон зажима	Макс. вылет кулачков	Тип патрона	Диапазон зажима	Макс. вылет кулачков	Тип патрона	Диапазон зажима	Макс. вылет кулачков	Тип патрона	Диапазон зажима	Макс. вылет кулачков	Тип патрона	Диапазон зажима	Макс. вылет кулачков	Тип патрона
	91 - 157	341	HSG 315	81 - 152	339	NH/NHF 315	81 - 152	338	KFD 315	80 - 145	331	HFK/HFKS 315	80 - 136	322	HES/HESF 315
	81 - 157	344	HSL 315	80 - 135	324	KG/KS/KT 315	81 - 152	339	KFD-HF 315	80 - 146	332	KFMK 315	80 - 133	319	KF 315
	82 - 150	337	ROTA NC/TH 315; ROTA NCF/THF 315	81 - 157	344	QLC/QLK 315	81 - 152	339	KFD-HS 315	81 - 148	334	AL-D/AN-D 315	80 - 138	324	KHFF 315
	81 - 163	345	ROTA NCD 315				81 - 152	339	KFH 315	104 - 147	333	BB-D 315			
	82 - 172	360	TP 315; ROTA TP 315				81 - 152	339	KFL 315	81 - 148	333	BH-D 315			
	81 - 161	348	ROTA NCK plus 315							81 - 148	333	HFKN-D 315			
										92 - 154	337	BHD-FC 315			
										136 - 240	428	GHD 400			
	146 - 217	341	HSG 315	128 - 207	331	NH/NHF 315	138 - 206	330	KFD 315	140 - 209	333	HFK/HFKS 315	130 - 200	324	HES/HESF 315
	130 - 211	336	HSL 315	135 - 200	326	KG/KS/KT 315	138 - 207	331	KFD-HF 315	140 - 208	332	KFMK 315	130 - 197	321	KF 315
	125 - 204	329	ROTA NC/TH 315; ROTA NCF/THF 315	128 - 212	336	QLC/QLK 315	138 - 207	331	KFD-HS 315	128 - 202	326	AL-D/AN-D 315	130 - 202	326	KHFF 315
	128 - 213	337	ROTA NCD 315	180 - 291	415	NHF 400 S 12	138 - 207	331	KFH 315	157 - 201	325	BB-D 315			
	129 - 227	352	TP 315; ROTA TP 315	180 - 283	407	KS/KSH/KSHF 400	138 - 207	331	KFL 315	127 - 202	326	BH-D 315			
	125 - 215	340	ROTA NCK plus 315							127 - 202	326	HFKN-D 315			
										131 - 197	325	BHD-FC 315			
										190 - 265	420	GHD 400			
	217 - 283	333	HSG 315	183 - 281	331	NH/NHF 315	204 - 280	330	KFD 315	208 - 283	333	HFK/HFKS 315	200 - 274	324	HES/HESF 315
	204 - 215	336	HSL 315	200 - 273	626	KG/KS/KT 315	205 - 281	331	KFD-HF 315	210 - 282	332	KFMK 315	196 - 271	321	KF 315
	199 - 278	329	ROTA NC/TH 315; ROTA NCF/THF 315	182 - 286	336	QLC/QLK 315	205 - 281	331	KFD-HS 315	188 - 276	326	AL-D/AN-D 315	200 - 276	326	KHFF 315
	195 - 287	337	ROTA NCD 315	270 - 357	415	NHF 400 S 12	205 - 281	331	KFH 315	231 - 275	325	BB-D 315			
	202 - 301	352	TP 315; ROTA TP 315	270 - 357	415	KS/KSH/KSHF 400	204 - 281	331	KFL 315	201 - 276	326	BH-D 315			
	199 - 289	340	ROTA NCK plus 315							201 - 276	326	HFKN-D 315			
										206 - 270	325	BHD-FC 315			
										264 - 369	420	GHD 400			
										125 - 245	431	BHD-FC 400			
										241 - 363	420	BHD-FC 400			

1  
2  
3  
4  
5  
6  
7  
C

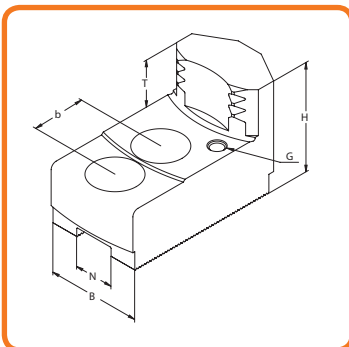

SZCZĘKI CHWYTAKOWE - MOCOWANIE ZEWNĘTRZNE

КУЛАЧКИ ЗУБЧАТЫЕ - ВНЕШНИЙ ЗАЖИМ

CAŁOWA WIELKOŚĆ KĄTA ZĄBKÓW 3/32" x 90°

ДЮЙМОВОЕ ЗУБЧАТОЕ СОЕДИНЕНИЕ 3/32" x 90°



Możliwość regulacji głębokości mocowania przedmiotu obrabianego „T”, za pomocą wymiennych kołków опорowych.

Śruby nie wchodzą w zakres dostawy i muszą być zamawiane oddzielnie.

Возможность регулировки глубины крепления обрабатываемой детали «Т» при помощи съемных опорных шпилек.

Эти шпильки не входят в комплект поставки и должны быть заказаны отдельно.

Nr produktu	Typ szczęk	N	B	H	T	G	b	Śruby	kg / kpl.
								Винты	кг / кпл.
398522612000	SZKB C400-25,5-11	25,5	60	78	33	M 8	35	M 20	8,8
398522614500	SZKB C400-25,5-13	25,5	60	78	33	M 8	35	M 20	7,4
398522615800	SZKB C400-25,5-14	25,5	60	78	33	M 8	35	M 20	5,1
398522616000	SZKB C400-25,5-15	25,5	60	78	33	M 8	35	M 20	6,3
398522613200	SZKB C400-25,5-12	25,5	60	78	33	M 8	35	M 20	8,7
398522614500	SZKB C400-25,5-13	25,5	60	78	33	M 8	35	M 20	7,4
398522615800	SZKB C400-25,5-14	25,5	60	78	33	M 8	35	M 20	5,1
398522616000	SZKB C400-25,5-15	25,5	60	78	33	M 8	35	M 20	6,3

Ø 400 mm

**Kołki опорowe** str. 503  
 Опорные шпильки стр.

**Wkładki teowe** str. 492-501  
 Т-образные вкладки стр.

Dystrybucja: unihurt.pl  
 Zamówienia: info@unihurt.pl

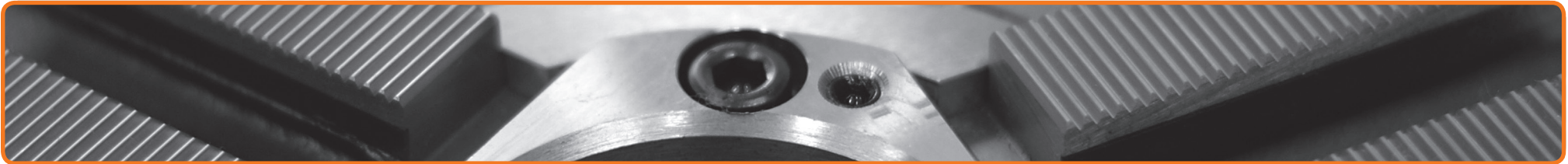

Ø 400 mm	SCHUNK			FORKARDT			RÖHM			SMW-AUTOBLOK			BERG		
	Zakres mocowania	Max. wysięg szczęk	Typ uchwytu	Zakres mocowania	Max. wysięg szczęk	Typ uchwytu	Zakres mocowania	Max. wysięg szczęk	Typ uchwytu	Zakres mocowania	Max. wysięg szczęk	Typ uchwytu	Zakres mocowania	Max. wysięg szczęk	Typ uchwytu
	Диапазон зажима	Макс. вылет кулачков	Тип патрона	Диапазон зажима	Макс. вылет кулачков	Тип патрона	Диапазон зажима	Макс. вылет кулачков	Тип патрона	Диапазон зажима	Макс. вылет кулачков	Тип патрона	Диапазон зажима	Макс. вылет кулачков	Тип патрона
	104 - 199	425	HSG 400	101 - 185	412	NH/NHF 400	101 - 183	410	KFD 400	100 - 180	407	HFH/HFKS 400	100 - 180	407	HES/HESF 400; KF/KHFF 400
	110 - 185	412	HSL 400	100 - 180	407	KG/KL 400	101 - 183	410	KFD-HF 400	101 - 183	410	BH-D 400			
	98 - 185	412	ROTA NC/TH 400; ROTA NCF/THF 400	100 - 180	407	KT/KTGF 400	101 - 183	410	KFD-HS 400	101 - 185	412	AL-D/AN-D 400			
	101 - 188	416	ROTA NCD 400	101 - 183	410	QLC/QLK 400	101 - 183	410	KFH 400	104 - 192 101 - 243	418 470	HFKN-D 400 BH-D 450			
	183 - 278	453	HSG 400	157 - 265	440	NH/NHF 400	176 - 263	438	KFD 400	180 - 260	435	HFH/HFKS 400	180 - 260	435	HES/HESF 400; KF/KHFF 400
	182 - 265	440	HSL 400	180 - 260	435	KG/KL 400	179 - 263	438	KFD-HF 400	181 - 263	438	BH-D 400			
	177 - 265	440	ROTA NC/TH 400; ROTA NCF/THF 400	180 - 260	435	KT/KTGF 400	173 - 263	438	KFD-HS 400	190 - 265	440	AL-D/AN-D 400			
	165 - 268	444	ROTA NCD 400	165 - 263	438	QLC/QLK 400	175 - 263	438	KFH 400	183 - 271 181 - 323	446 498	HFKN-D 400 BH-D 450			
	263 - 358	453	HSG 400	235 - 344	440	NH/NHF 400	235 - 342	438	KFD 400	260 - 340	435	HFH/HFKS 400	260 - 340	435	HES/HESF 400; KF/KHFF 400
	268 - 344	440	HSL 400	260 - 340	435	KG/KL 400	247 - 342	438	KFD-HF 400	258 - 342	438	BH-D 400			
	259 - 359	456	ROTA NC/TH 400; ROTA NCF/THF 400	260 - 340	435	KT/KTGF 400	251 - 342	438	KFD-HS 400	259 - 343	440	AL-D/AN-D 400			
	243 - 347	444	ROTA NCD 400	243 - 342	438	QLC/QLK 400	243 - 342	438	KFH 400	263 - 350 258 - 402	446 498	HFKN-D 400 BH-D 450			
	326 - 421	461	HSG 400	299 - 408	448	NH/NHF 400	310 - 400	446	KFD 400	340 - 400	440	HFH/HFKS 400	340 - 400	440	HES/HESF 400; KF/KHFF 400
	331 - 408	448	HSL 400	340 - 400	440	KG/KL 400	310 - 400	446	KFD-HF 400	322 - 406	446	BH-D 400			
	319 - 407	448	ROTA NC/TH 400; ROTA NCF/THF 400	340 - 400	440	KT/KTGF 400	314 - 400	446	KFD-HS 400	322 - 408	446	AL-D/AN-D 400			
	307 - 411	452	ROTA NCD 400	307 - 406	446	QLC/QLK 400	307 - 400	446	KFH 400	326 - 414 322 - 466	454 506	HFKN-D 400 BH-D 450			
	148 - 285	550	HSG 500	125 - 279	546	NHF 500				150 - 275	540	HFH/HFKS 500			
	156 - 278	545	ROTA NC/TH 500; ROTA NCF/THF 500	150 - 275	540	KG/KS 500				150 - 275	540	HFKN-D 500			
	125 - 283	551	ROTA NCD 500	150 - 275	540	KS/KT 630				190 - 440	708	BH-D 630			
				150 - 275	540	NHF 630									
	230 - 375	550	HSG 500	196 - 362	538	NHF 500				225 - 350	525	HFH/HFKS 500			
	238 - 361	537	ROTA NC/TH 500; ROTA NCF/THF 500	225 - 350	525	KG/KS 500				225 - 350	525	HFKN-D 500			
	164 - 366	543	ROTA NCD 500	275 - 400	575	KS/KT 630				275 - 520	700	BH-D 630			
				250 - 400	575	NHF 630									
	310 - 455	550	HSG 500	275 - 441	538	NHF 500				300 - 425	520	HFH/HFKS 500			
	316 - 440	537	ROTA NC/TH 500; ROTA NCF/THF 500	300 - 425	520	KG/KS 500				300 - 425	520	HFKN-D 500			
	242 - 445	543	ROTA NCD 500	350 - 500	595	KS/KT 630				355 - 603	700	BH-D 630			
	373 - 518	558	HSG 500	338 - 505	546	NHF 500				400 - 500	540	HFH/HFKS 500			
	386 - 520	561	ROTA NC/TH 500; ROTA NCF/THF 500	400 - 500	540	KG/KS 500				400 - 500	540	HFKN-D 500			
	300 - 509	551	ROTA NCD 500	500 - 600	640	KS/KT 630				415 - 665	708	BH-D 630			
				400 - 600	640	NHF 630									

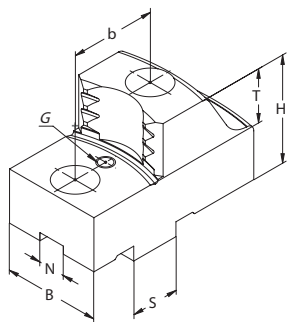

SZCZĘKI CHWYTAKOWE - MOCOWANIE WEWNĘTRZNE

КУЛАЧКИ ЗУБЧАТЫЕ - ВНУТРЕННИЙ ЗАЖИМ

Z WPUSTEM I ROWKIEM

С СИСТЕМОЙ ПАЗ-ШПОНКА

Możliwość regulacji głębokości mocowania przedmiotu obrabianego „T”, za pomocą wymiennych kołków опорowych.

Śruby nie wchodzą w zakres dostawy i muszą być zamawiane oddzielnie.

Возможность регулировки глубины крепления обрабатываемой детали «Т» при помощи съемных опорных шпилек.

Эти шпильки не входят в комплект поставки и должны быть заказаны отдельно.

Pozycja szczęk podstawowych  
 Положение мастер кулачков

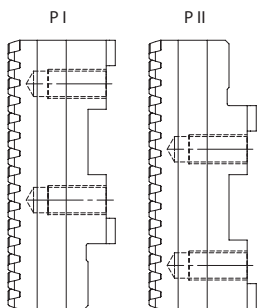

OŚ BISON  
 Ось BISON

Ø 160 - 185 mm

Nr produktu	Typ szczęk	N	S	B	H	T	G	b	kg / kpl.	Pozycja szczęk podstawowych
Код продукта	Тип кулачков								кг / кпл.	Положение мастер кулачков
398522753000	SWKB Z160-18-69	8	18	26	40	20	M 6	32	0,9	II
398522753000	SWKB Z160-18-69	8	18	26	40	20	M 6	32	0,9	I
398522750200	SWKB Z160-18-63	8	18	40	40	20	M 6	32	1,3	II
398522750200	SWKB Z160-18-63	8	18	40	40	20	M 6	32	1,3	I
398522751500	SWKB Z160-18-67	8	18	30	40	20	M 6	32	1,3	II
398522751500	SWKB Z160-18-67	8	18	30	40	20	M 6	32	1,3	I
398522752800	SWKB Z160-18-68	8	18	30	40	20	M 6	32	1,4	II
398522753000	SWKB Z160-18-69	8	18	26	40	20	M 6	32	0,9	II
398522753000	SWKB Z160-18-69	8	18	26	40	20	M 6	32	0,9	I
398522750200	SWKB Z160-18-63	8	18	40	40	20	M 6	32	1,3	II
398522750200	SWKB Z160-18-63	8	18	40	40	20	M 6	32	1,3	I
398522751500	SWKB Z160-18-67	8	18	30	40	20	M 6	32	1,3	II
398522752800	SWKB Z160-18-68	8	18	30	40	20	M 6	32	1,4	II
398522753000	SWKB Z160-18-69	8	18	26	40	20	M 6	32	0,9	I
398522750200	SWKB Z160-18-63	8	18	40	40	20	M 6	32	1,3	II
398522750200	SWKB Z160-18-63	8	18	40	40	20	M 6	32	1,3	I
398522751500	SWKB Z160-18-67	8	18	30	40	20	M 6	32	1,3	II
398522751500	SWKB Z160-18-67	8	18	30	40	20	M 6	32	1,3	I
398522752800	SWKB Z160-18-68	8	18	30	40	20	M 6	32	1,4	II
398522753000	SWKB Z160-18-69	8	18	26	40	20	M 6	32	0,9	I
398522750200	SWKB Z160-18-63	8	18	40	40	20	M 6	32	1,3	II
398522750200	SWKB Z160-18-63	8	18	40	40	20	M 6	32	1,3	I
398522751500	SWKB Z160-18-67	8	18	30	40	20	M 6	32	1,3	II
398522751500	SWKB Z160-18-67	8	18	30	40	20	M 6	32	1,3	I
398522753000	SWKB Z160-18-69	8	18	26	40	20	M 6	32	0,9	II
398522750200	SWKB Z160-18-63	8	18	40	40	20	M 6	32	1,3	II
398522750200	SWKB Z160-18-63	8	18	40	40	20	M 6	32	1,3	I
398522751500	SWKB Z160-18-67	8	18	30	40	20	M 6	32	1,3	II
398522751500	SWKB Z160-18-67	8	18	30	40	20	M 6	32	1,3	I
398522752800	SWKB Z160-18-68	8	18	30	40	20	M 6	32	1,4	II
398522753000	SWKB Z160-18-69	8	18	26	40	20	M 6	32	0,9	I
398522750200	SWKB Z160-18-63	8	18	40	40	20	M 6	32	1,3	I
398522751500	SWKB Z160-18-67	8	18	30	40	20	M 6	32	1,3	II
398522753000	SWKB Z160-18-69	8	18	26	40	20	M 6	32	0,9	I
398522750200	SWKB Z160-18-63	8	18	40	40	20	M 6	32	1,3	I
398522751500	SWKB Z160-18-67	8	18	30	40	20	M 6	32	1,3	II
398522751500	SWKB Z160-18-67	8	18	30	40	20	M 6	32	1,3	I
398522752800	SWKB Z160-18-68	8	18	30	40	20	M 6	32	1,4	II
398522753000	SWKB Z160-18-69	8	18	26	40	20	M 6	32	0,9	II

Kołki опорowe str. 503  
 Опорные шпильки стр.



1

2

3

4

5

6

7

C

SWKB Z

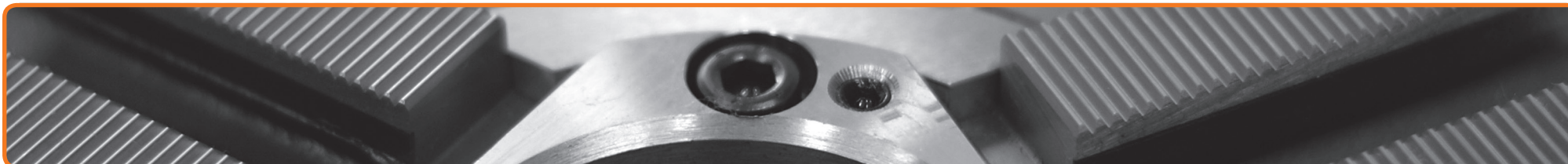

Ø 160 - 185 mm	SCHUNK			FORKARDT			RÖHM			SMW-AUTOBLOK			BERG		
	Zakres mocowania	Max. wysięg szczęk	Typ uchwytu	Zakres mocowania	Max. wysięg szczęk	Typ uchwytu	Zakres mocowania	Max. wysięg szczęk	Typ uchwytu	Zakres mocowania	Max. wysięg szczęk	Typ uchwytu	Zakres mocowania	Max. wysięg szczęk	Typ uchwytu
	Диапазон зажима	Макс. вылет кулачков	Тип патрона	Диапазон зажима	Макс. вылет кулачков	Тип патрона	Диапазон зажима	Макс. вылет кулачков	Тип патрона	Диапазон зажима	Макс. вылет кулачков	Тип патрона	Диапазон зажима	Макс. вылет кулачков	Тип патрона
	32 - 87	207	ROTA-G 160	26 - 53	209	F 160	36 - 53	213	DURO 160						
	63 - 116	206	ROTA-G 160	42 - 87	208	F 160	42 - 87	208	DURO 160	37 - 72	193	HG-F 160	40 - 85	207	KHNC 160
	81 - 133	213	ROTA-G 160	65 - 89	208	F 160	64 - 94	209	DURO 160	59 - 85	193	HG-F 160	59 - 105	214	KHNC 160
	113 - 167	228	ROTA-G 160	90 - 135	216	F 160	90 - 135	216	DURO 160	85 - 120	201	HG-F 160	88 - 133	215	KHNC 160
	131 - 185	246	ROTA-G 160				124 - 151	213	DURO 160				110 - 156	218	KHNC 160
				129 - 154	208	F 160				114 - 141	193	HG-F 160			
				27 - 53	209	F+ 160	43 - 52	208	DURO-NC 160	28 - 71	192	HG-N 160			
	41 - 97	217	ROTA-S plus 160	43 - 88	209	F+ 160	51 - 87	208	DURO-NC 160						
	55 - 109	217	ROTA-S plus 160	55 - 100	209	F+ 160	63 - 100	208	DURO-NC 160	57 - 91	181	HG-N 160			
	89 - 144	225	ROTA-S plus 160	90 - 136	217	F+ 160	98 - 145	226	DURO-NC 160	84 - 119	200	HG-N 160			
	104 - 160	221	ROTA-S plus 160				114 - 151	208	DURO-NC 160						
				110 - 157	209	F+ 160				112 - 156	191	HG-N 160			
	26 - 57	177	THW 165-R	48 - 84	205	KTNC 160	48 - 93	214	DURO-NCE 160						
	55 - 87	177	THW 165-R	61 - 97	206	KTNC 160	60 - 196	214	DURO-NCE 160						
	71 - 104	185	THW 165-R	95 - 132	213	KTNC 160	95 - 141	222	DURO-NCE 160						
	104 - 137	199	THW 165-R				120 - 157	214	DURO-NCE 160						
	122 - 155	217	THW 165-R												
				116 - 154	210	KTNC 160									
	33 - 68	190	ROTA THW plus 165												
	64 - 98	190	ROTA THW plus 165												
	72 - 116	198	ROTA THW plus 165												
	105 - 149	212	ROTA THW plus 165												
	123 - 167	230	ROTA THW plus 165												
										38 - 71	192	KNCS-N 170			
										68 - 102	192	KNCS-N 170			
										86 - 120	200	KNCS-N 170			
										119 - 153	214	KNCS-N 170			
				49 - 107	228	KTNCV 175	47 - 89	228	DURO-NC 175	31 - 66	186	KNCS 175			
							70 - 106	221	DURO-NC 175	61 - 95	186	KNCS 175			
				97 - 105	236	KTNCV 175	94 - 129	227	DURO-NC 175	79 - 113	194	KNCS 175			
							129 - 161	217	DURO-NC 175	111 - 146	186	KNCS 175			
				117 - 175	228	KTNCV 175				116 - 151	186	KNCS 175			
				54 - 101	222	FNC 175	46 - 103	224	DURO-NCES 175						
				101 - 149	230	FNC 175	94 - 141	232	DURO-NCES 175						
							109 - 166	224	DURO-NCES 175						
				122 - 169	222	FNC 175									
							36 - 74	192	DURO-NCES 175						
							74 - 119	200	DURO-NCES 175						
							106 - 153	214	DURO-NCES 175						
	27 - 90	212	ROTA THW plus 185										55 - 101	222	KHNC 185
	74 - 138	220	ROTA THW plus 185										102 - 148	258	KHNC 185
													125 - 170	233	KHNC 185
													153 - 199	262	KHNC 185
	111 - 176	234	ROTA THW plus 185												

- 1
- 2
- 3
- 4
- 5
- 6

7  
 Dystrybucja: unihurt.pl  
  
 Zamówienia: info@unihurt.pl KMS



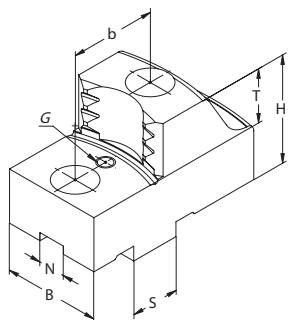

SZCZĘKI CHWYTAKOWE - MOCOWANIE WEWNĘTRZNE

КУЛАЧКИ ЗУБЧАТЫЕ - ВНУТРЕННИЙ ЗАЖИМ

Z WPUSTEM I ROWKIEM

С СИСТЕМОЙ ПАЗ-ШПОНКА

Możliwość regulacji głębokości mocowania przedmiotu obrabianego „T”, za pomocą wymiennych kołków опорowych.

Śruby nie wchodzi w zakres dostawy i muszą być zamawiane oddzielnie.

Возможность регулировки глубины крепления обрабатываемой детали «Т» при помощи съемных опорных шпилек.

Эти шпильки не входят в комплект поставки и должны быть заказаны отдельно.

Pozycja szczęk podstawowych  
 Положение мастер кулачков

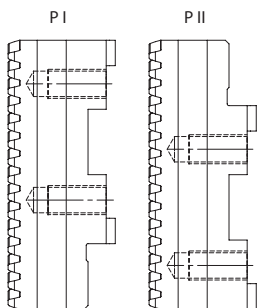

Oś BISON  
 Ось BISON

Nr produktu	Typ szczęk	N	S	B	H	T	G	b	kg / kpl.	Pozycja szczęk podstawowych
									кг / кпл.	Положение мастер кулачков
398522754300	SWKB Z200-20-12	10	20	26	45	25	M 6	40	1,3	I
398522755600	SWKB Z200-20-13	10	20	30	45	25	M 6	40	1,2	II
398522755600	SWKB Z200-20-13	10	20	30	45	25	M 6	40	1,2	I
398522756900	SWKB Z200-20-16	10	20	30	45	25	M 6	40	1,2	I
398522754300	SWKB Z200-20-12	10	20	26	45	25	M 6	40	1,3	I
398522755600	SWKB Z200-20-13	10	20	30	45	25	M 6	40	1,2	II
398522755600	SWKB Z200-20-13	10	20	30	45	25	M 6	40	1,2	I
398522756900	SWKB Z200-20-16	10	20	30	45	25	M 6	40	1,2	I
398522754300	SWKB Z200-20-12	10	20	26	45	25	M 6	40	1,3	I
398522755600	SWKB Z200-20-13	10	20	30	45	25	M 6	40	1,2	II
398522755600	SWKB Z200-20-13	10	20	30	45	25	M 6	40	1,2	I
398522756900	SWKB Z200-20-16	10	20	30	45	25	M 6	40	1,2	I
398522754300	SWKB Z200-20-12	10	20	26	45	25	M 6	40	1,3	I
398522755600	SWKB Z200-20-13	10	20	30	45	25	M 6	40	1,2	II
398522755600	SWKB Z200-20-13	10	20	30	45	25	M 6	40	1,2	I
398522756900	SWKB Z200-20-16	10	20	30	45	25	M 6	40	1,2	I
398522754300	SWKB Z200-20-12	10	20	26	45	25	M 6	40	1,3	I
398522755600	SWKB Z200-20-13	10	20	30	45	25	M 6	40	1,2	ii
398522755600	SWKB Z200-20-13	10	20	30	45	25	M 6	40	1,2	I
398522756900	SWKB Z200-20-16	10	20	30	45	25	M 6	40	1,2	I
398522757100	SWKB Z250-20-63	12	20	30	50	25	M 6	40	1,2	II
398522757100	SWKB Z250-20-63	12	20	30	50	25	M 6	40	1,2	I
398522758400	SWKB Z250-20-66	12	20	40	50	25	M 6	40	1,7	II
398522758400	SWKB Z250-20-66	12	20	40	50	25	M 6	40	1,7	I
398522759700	SWKB Z250-20-68	12	20	40	50	25	M 6	40	1,8	I
398522759700	SWKB Z250-20-68	12	20	40	50	25	M 6	40	1,8	II
398522757100	SWKB Z250-20-63	12	20	30	50	25	M 6	40	1,2	II
398522758400	SWKB Z250-20-66	12	20	40	50	25	M 6	40	1,7	II
398522758400	SWKB Z250-20-66	12	20	40	50	25	M 6	40	1,7	I
398522759700	SWKB Z250-20-68	12	20	40	50	25	M 6	40	1,8	I
398522759700	SWKB Z250-20-68	12	20	40	50	25	M 6	40	1,8	II
398522757100	SWKB Z250-20-63	12	20	30	50	25	M 6	40	1,2	II
398522758400	SWKB Z250-20-66	12	20	40	50	25	M 6	40	1,7	II
398522758400	SWKB Z250-20-66	12	20	40	50	25	M 6	40	1,7	I
398522759700	SWKB Z250-20-68	12	20	40	50	25	M 6	40	1,8	I
398522759700	SWKB Z250-20-68	12	20	40	50	25	M 6	40	1,8	II
398522757100	SWKB Z250-20-63	12	20	30	50	25	M 6	40	1,2	II
398522758400	SWKB Z250-20-66	12	20	40	50	25	M 6	40	1,7	II
398522758400	SWKB Z250-20-66	12	20	40	50	25	M 6	40	1,7	I
398522759700	SWKB Z250-20-68	12	20	40	50	25	M 6	40	1,8	I
398522759700	SWKB Z250-20-68	12	20	40	50	25	M 6	40	1,8	II
398522757100	SWKB Z250-20-63	12	20	30	50	25	M 6	40	1,2	II
398522758400	SWKB Z250-20-66	12	20	40	50	25	M 6	40	1,7	II
398522758400	SWKB Z250-20-66	12	20	40	50	25	M 6	40	1,7	I
398522759700	SWKB Z250-20-68	12	20	40	50	25	M 6	40	1,8	I
398522759700	SWKB Z250-20-68	12	20	40	50	25	M 6	40	1,8	II

Kołki опорowe str. 503  
 Опорные шпильки стр.



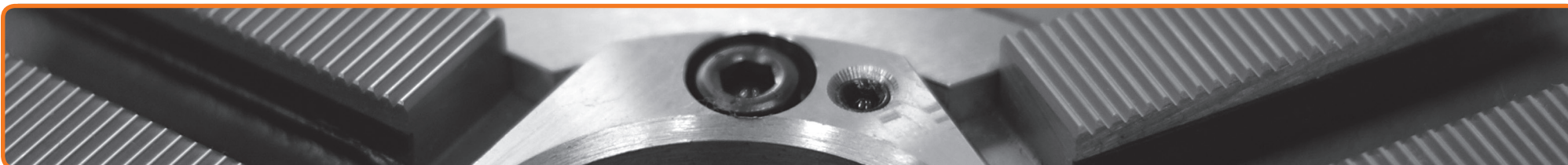

Ø 200 - 260 mm	SCHUNK			FORKARDT			RÖHM			SMW-AUTOBLOK			BERG		
	Zakres mocowania	Max. wysięg szczęk	Typ uchwytu	Zakres mocowania	Max. wysięg szczęk	Typ uchwytu	Zakres mocowania	Max. wysięg szczęk	Typ uchwytu	Zakres mocowania	Max. wysięg szczęk	Typ uchwytu	Zakres mocowania	Max. wysięg szczęk	Typ uchwytu
	Диапазон зажима	Макс. вылет кулачков	Тип патрона	Диапазон зажима	Макс. вылет кулачков	Тип патрона	Диапазон зажима	Макс. вылет кулачков	Тип патрона	Диапазон зажима	Макс. вылет кулачков	Тип патрона	Диапазон зажима	Макс. вылет кулачков	Тип патрона
23 - 107	278	ROTA-G 200	30 - 85	252	F 200	26 - 90	256	DURO 200	28 - 73	240	HG-F 210	33 - 71	236	KHNC 200	
73 - 145	274	ROTA-G 200	69 - 114	252	F 200	64 - 136	275	DURO 200	71 - 108	247	HG-F 210	67 - 112	253	KHNC 200	
110 - 184	276	ROTA-G 200	115 - 160	250	F 200	98 - 165	265	DURO 200	102 - 149	240	HG-F 210	109 - 146	239	KHNC 200	
145 - 220	282	ROTA-G 200	161 - 196	257	F 200	132 - 200	262	DURO 200	137 - 184	246	HG-F 210	145 - 190	255	KHNC 200	
34 - 83	254	ROTA-S plus 200	32 - 91	263	F+ 200	28 - 124	291	DURO-NC 200	29 - 73	240	HG-F 210				
64 - 128	267	ROTA-S plus 200	64 - 124	263	F+ 200	54 - 152	291	DURO-NC 200	66 - 111	240	HG-F 210				
109 - 175	267	ROTA-S plus 200	106 - 172	263	F+ 200	103 - 199	291	DURO-NC 200	103 - 149	240	HG-F 210				
141 - 208	244	ROTA-S plus 200	141 - 200	263	F+ 200	138 - 200	268	DURO-NC 200	138 - 184	246	HG-F 210				
28 - 82	248	THW 210-R	37 - 75	241	KTNC 200	34 - 90	256	DURO-NCE 200	34 - 70	236	KNCS 200				
66 - 119	250	THW 210-R	65 - 103	241	KTNC 200	64 - 107	246	DURO-NCE 200	71 - 107	236	KNCS 200				
103 - 157	248	THW 210-R	112 - 150	241	KTNC 200	108 - 165	256	DURO-NCE 200	108 - 145	236	KNCS 200				
138 - 192	254	THW 210-R	147 - 185	247	KTNC 200	143 - 200	262	DURO-NCE 200	143 - 180	242	KNCS 200				
36 - 83	254	ROTA NCWF 210	39 - 96	263	KTNCV 200	28 - 114	281	DURO-NCES 200	29 - 90	257	KNCS-N 210				
78 - 115	254	ROTA NCWF 210	66 - 124	263	KTNCV 200				74 - 137	267	KNCS-N 210				
101 - 157	254	ROTA NCWF 210	113 - 172	263	KTNCV 200	102 - 190	281	DURO-NCES 200							
142 - 198	260	ROTA NCWF 210	148 - 207	269	KTNCV 200	137 - 200	268	DURO-NCES 200	137 - 201	263	KNCS-N 210				
31 - 96	264	ROTA THW plus 215	39 - 96	263	FNC 200	26 - 100	267	DURO-NCES 200							
			67 - 124	263	FNC 200	64 - 137	267	DURO-NCES 200							
96 - 171	264	ROTA THW plus 215	114 - 172	263	FNC 200										
131 - 207	270	ROTA THW plus 215	149 - 207	269	FNC 200	135 - 200	263	DURO-NCES 200							
33 - 126	334	ROTA-G 250	40 - 88	306	F 250	31 - 103	326	DURO 250	31 - 61	283	HG-F 260	31 - 75	286	KHNC 250	
86 - 181	334	ROTA-G 250													
			86 - 158	318	F 250	80 - 160	326	DURO 250	74 - 129	295	HG-F 260	75 - 120	286	KHNC 250	
140 - 237	336	ROTA-G 250	158 - 212	304	F 250	155 - 224	319	DURO 250	135 - 204	298	HG-F 260				
176 - 250	348	ROTA-G 250	194 - 248	304	F 250	189 - 250	333	DURO 250	168 - 238	312	HG-F 260	180 - 248	304	KHNC 250	
												119 - 154	286	KHNC 250	
31 - 99	322	ROTA-S plus 250	31 - 97	320	F+ 250	31 - 101	336	DURO-NC 250	33 - 74	284	HG-N 260				
74 - 154	324	ROTA-S plus 250	74 - 148	320	F+ 250	76 - 170	336	DURO-NC 250	74 - 131	284	HG-N 260				
148 - 229	328	ROTA-S plus 250	148 - 223	324	F+ 250	151 - 246	340	DURO-NC 250	130 - 194	288	HG-N 260				
181 - 263	336	ROTA-S plus 250	163 - 250	324	F+ 250	184 - 250	330	DURO-NC 250	173 - 238	313	HG-N 260				
31 - 86	297	THW 250-R	31 - 84	307	KTNC 250	31 - 85	308	DURO-NCE 250	42 - 82	293	KNCS 250				
82 - 143	297	THW 250-R	82 - 151	317	KTNC 250	85 - 142	308	DURO-NCE 250	77 - 139	293	KNCS 250				
144 - 207	301	THW 250-R	159 - 217	311	KTNC 250	160 - 218	312	DURO-NCE 250	139 - 191	285	KNCS 250				
177 - 240	315	THW 250-R	192 - 250	325	KTNC 250	193 - 251	326	DURO-NCE 250	182 - 235	310	KNCS 250				
32 - 80	303	ROTA NCWF 250	31 - 107	326	KTNCV 250	31 - 99	312	DURO-NCES 250							
80 - 137	303	ROTA NCWF 250	82 - 164	326	KTNCV 250	76 - 152	324	DURO-NCES 250							
			157 - 240	334	KTNCV 250	151 - 222	316	DURO-NCES 250							
119 - 171	303	ROTA NCWF 250	190 - 250	325	KTNCV 250	195 - 255	330	DURO-NCES 250							
155 - 213	307	ROTA NCWF 250													
188 - 246	321	ROTA NCWF 250													
37 - 100	313	ROTA THW plus 260	40 - 107	330	FNC 250	31 - 92	303	DURO-NCES 250	39 - 103	314	KNCS-N 260				
82 - 157	313	ROTA THW plus 260	86 - 164	330	FNC 250	84 - 149	303	DURO-NCES 250	76 - 150	303	KNCS-N 260				
145 - 221	317	ROTA THW plus 260	157 - 228	322	FNC 250	137 - 224	318	DURO-NCES 250	139 - 213	307	KNCS-N 260				
178 - 255	331	ROTA THW plus 260	190 - 250	324	FNC 250	180 - 247	321	DURO-NCES 250	172 - 236	310	KNCS-N 260				

- 1
  - 2
  - 3
  - 4
  - 5
  - 6
  - 7
- Dystrybucja: unihurt.pl
- Zamówienia: info@unihurt.pl
- KMS





1  
2  
3  
4  
5  
6  
7  
C

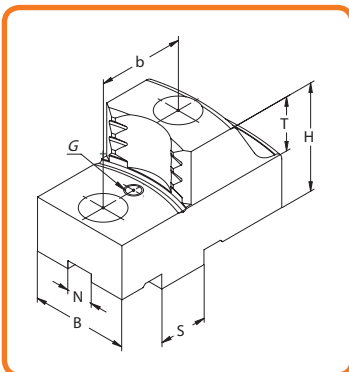

**SZCZĘKI CHWYTAKOWE • MOCOWANIE WEWNĘTRZNE**  
 КУЛАЧКИ ЗУБЧАТЫЕ • ВНУТРЕННИЙ ЗАЖИМ

**Z WPUSTEM I ROWKIEM**  
 С СИСТЕМОЙ ПАЗ-ШПОНКА

- Możliwość regulacji głębokości mocowania przedmiotu obrabianego „T”, za pomocą wymiennych kołków опорowych.
- Śruby nie wchodzą w zakres dostawy i muszą być zamawiane oddzielnie.
- Возможность регулировки глубины крепления обрабатываемой детали «Т» при помощи съемных опорных шпилек.
- Эти шпильки не входят в комплект поставки и должны быть заказаны отдельно.

**Pozycja szczęk podstawowych**  
 Положение мастер кулачков

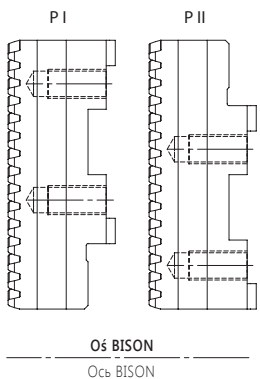

Ø 250 - 315 mm

Nr produktu	Typ szczęk	N	S	B	H	T	G	b	kg / kpl.	Pozycja szczęk podstawowych
Код продукта	Тип кулачков								кг / кпл.	Положение мастер кулачков
398522757100	SWKB Z250-20-63	12	20	30	50	25	M 6	40	1,4	II
398522757100	SWKB Z250-20-63	12	20	30	50	25	M 6	40	1,4	I
398522759700	SWKB Z250-20-68	12	20	40	50	25	M 6	40	2,2	I
398522760400	SWKB Z315-26-21	12	26	40	53	25	M 8	54	2,8	II
398522760400	SWKB Z315-26-21	12	26	40	53	25	M 8	54	2,8	I
398522761700	SWKB Z315-26-24	12	26	40	53	25	M 8	54	2,3	II
398522761700	SWKB Z315-26-24	12	26	40	53	25	M 8	54	2,3	I
398522760400	SWKB Z315-26-21	12	26	40	53	25	M 8	54	2,8	II
398522761700	SWKB Z315-26-24	12	26	40	53	25	M 8	54	2,3	II
398522761700	SWKB Z315-26-24	12	26	40	53	25	M 8	54	2,3	I
398522757100	SWKB Z250-20-63	12	20	30	50	25	M 6	40	1,4	II
398522758400	SWKB Z250-20-66	12	20	40	50	25	M 6	40	1,9	II
398522759700	SWKB Z250-20-68	12	20	40	50	25	M 6	40	2,2	II
398522759700	SWKB Z250-20-68	12	20	40	50	25	M 6	40	2,2	I
398522757100	SWKB Z250-20-63	12	20	30	50	25	M 6	40	1,4	II
398522758400	SWKB Z250-20-66	12	20	40	50	25	M 6	40	1,9	II
398522758400	SWKB Z250-20-66	12	20	40	50	25	M 6	40	1,9	I
398522759700	SWKB Z250-20-68	12	20	40	50	25	M 6	40	2,2	II
398522759700	SWKB Z250-20-68	12	20	40	50	25	M 6	40	2,2	I
398522757100	SWKB Z250-20-63	12	20	40	50	25	M 6	40	1,4	II
398522758400	SWKB Z250-20-66	12	20	40	50	25	M 6	40	1,9	II
398522758400	SWKB Z250-20-66	12	20	40	50	25	M 6	40	1,9	I
398522759700	SWKB Z250-20-68	12	20	40	50	25	M 6	40	2,2	II
398522759700	SWKB Z250-20-68	12	20	40	50	25	M 6	40	2,2	I
398522760400	SWKB Z315-26-21	12	26	40	53	25	M 8	54	2,8	II
398522761700	SWKB Z315-26-24	12	26	40	53	25	M 8	54	2,3	II
398522761700	SWKB Z315-26-24	12	26	40	53	25	M 8	54	2,3	I
398522757100	SWKB Z250-20-63	12	20	30	50	25	M 6	40	1,4	II
398522759700	SWKB Z250-20-68	12	20	40	50	25	M 6	40	2,2	II
398522759700	SWKB Z250-20-68	12	20	40	50	25	M 6	40	2,2	I
398522759700	SWKB Z250-20-68	12	20	40	50	25	M 6	40	2,2	I

**Kołki опорowe** str. 503  
 Опорные шпильки стр.



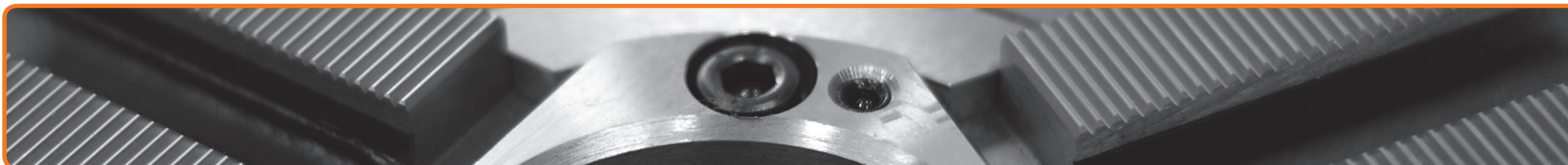

Ø 250 - 315 mm	SCHUNK			FORKARDT			RÖHM			SMW-AUTOBLOK			BERG		
	Zakres mocowania	Max. wysięg szczęk	Typ uchwytu	Zakres mocowania	Max. wysięg szczęk	Typ uchwytu	Zakres mocowania	Max. wysięg szczęk	Typ uchwytu	Zakres mocowania	Max. wysięg szczęk	Typ uchwytu	Zakres mocowania	Max. wysięg szczęk	Typ uchwytu
	Диапазон зажима	Макс. вылет кулачков	Тип патрона	Диапазон зажима	Макс. вылет кулачков	Тип патрона	Диапазон зажима	Макс. вылет кулачков	Тип патрона	Диапазон зажима	Макс. вылет кулачков	Тип патрона	Диапазон зажима	Макс. вылет кулачков	Тип патрона
	39 - 147	381	ROTA-G 315												
	111 - 232	385	ROTA-G 315												
	201 - 318	394	ROTA-G 315												
	44 - 133	400	ROTA-S plus 315	52 - 112	372	F 315	49 - 118	384	DURO 315						
	85 - 210	400	ROTA-S plus 315	105 - 150	330	F 315	110 - 181	370	DURO 315						
	115 - 233	402	ROTA-S plus 315	148 - 212	372	F 315	140 - 212	370	DURO 315						
	190 - 315	402	ROTA-S plus 315	214 - 292	372	F 315	208 - 303	392	DURO 315						
				50 - 118	384	F+ 315	55 - 153	419	DURO-NC 315	48 - 102	382	HG-F 315			
				119 - 218	384	F+ 315	133 - 261	419	DURO-NC 315	118 - 196	368	HG-F 315			
				191 - 295	384	F+ 315	210 - 311	399	DURO-NC 315	189 - 301	390	HG-F 315			
	31 - 112	346	THW 315-R	40 - 108	322	KTNC 315	57 - 138	362	DURO-NCE 315	39 - 117	351	HG-N 315	42 - 110	334	KHNC 315
	86 - 170	346	THW 315-R	85 - 165	331	KTNC 315							75 - 167	334	KHNC 315
	119 - 204	346	THW 315-R	129 - 199	354	KTNC 315	135 - 230	362	DURO-NCE 315	118 - 208	351	HG-N 315	119 - 201	334	KHNC 315
	206 - 291	366	THW 315-R	192 - 274	352	KTNC 315	211 - 305	380	DURO-NCE 315	205 - 296	371	HG-N 315	180 - 274	350	KHNC 315
	36 - 127	343	ROTA NCWF 315	40 - 100	318	KTNCV 315; FNC 315				49 - 101	335	KNCS 315			
	80 - 185	343	ROTA NCWF 315	86 - 152	318	KTNCV 315; FNC 315				95 - 170	346	KNCS 315			
										128 - 204	346	KNCS 315			
	124 - 217	343	ROTA NCWF 315	153 - 220	354	KTNCV 315; FNC 315									
	188 - 293	369	ROTA NCWF 315	218 - 296	352	KTNCV 315; FNC 315				204 - 280	355	KNCS 315			
	41 - 138	373	ROTA THW plus 315							38 - 124	357	KNCS-N 315			
										96 - 192	368	KNCS-N 315			
										173 - 269	363	KNCS-N 315			
	119 - 228	373	ROTA THW plus 315												
	202 - 313	389	ROTA THW plus 315							206 - 302	377	KNCS-N 315			
							46 - 139	267	DURO-NCES 315						
							123 - 247	267	DURO-NCES 315						
							200 - 315	413	DURO-NCES 315						
							35 - 131	370	DURO-NCES 315						
							123 - 222	370	DURO-NCES 315						
							204 - 302	377	DURO-NCES 315						



1  
2  
3  
4  
5  
6

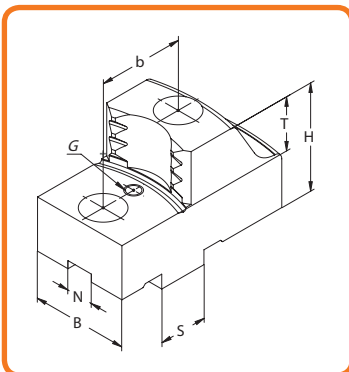

**SZCZĘKI CHWYTAKOWE - MOCOWANIE WEWNĘTRZNE**  
 КУЛАЧКИ ЗУБЧАТЫЕ - ВНУТРЕННИЙ ЗАЖИМ

**Z WPUSTEM I ROWKIEM**  
 С СИСТЕМОЙ ПАЗ-ШПОНКА

- Możliwość regulacji głębokości mocowania przedmiotu obrabianego „T”, za pomocą wymiennych kołków опорowych.
- Śruby nie wchodzą w zakres dostawy i muszą być zamawiane oddzielnie.
- Возможность регулировки глубины крепления обрабатываемой детали «Т» при помощи съемных опорных шпилек.
- Эти шпильки не входят в комплект поставки и должны быть заказаны отдельно.

**Pozycja szczęk podstawowych**  
 Положение мастер кулачков

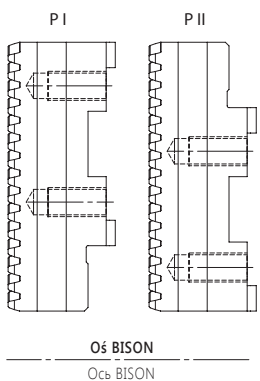

Oś BISON  
 Ось BISON

Nr produktu	Typ szczęk	N	S	B	H	T	G	b	kg / kpl.	Pozycja szczęk podstawowych
									кг / кпл.	Положение мастер кулачков
398522762000	SWKB Z400-30-09	18	30	50	71	33	M 8	60	5,2	II
398522763200	SWKB Z400-30-12	18	30	50	71	33	M 8	60	4,6	II
398522763200	SWKB Z400-30-12	18	30	50	71	33	M 8	60	4,6	I
398522762000	SWKB Z400-30-09	18	30	50	71	33	M 8	60	5,2	II
398522763200	SWKB Z400-30-12	18	30	50	71	33	M 8	60	4,6	II
398522763200	SWKB Z400-30-12	18	30	50	71	33	M 8	60	4,6	I
398522760400	SWKB Z315-26-21	12	26	40	53	25	M 8	54	3,1	I
398522760400	SWKB Z315-26-21	12	26	40	53	25	M 8	54	3,1	II
398522761700	SWKB Z315-26-24	12	26	40	53	25	M 8	54	2,8	II
398522761700	SWKB Z315-26-24	12	26	40	53	25	M 8	54	2,8	I
398522760400	SWKB Z315-26-21	12	26	40	53	25	M 8	54	3,1	II
398522761700	SWKB Z315-26-24	12	26	40	53	25	M 8	54	2,8	II
398522761700	SWKB Z315-26-24	12	26	40	53	25	M 8	54	2,8	I
398522762000	SWKB Z400-30-09	18	30	50	71	33	M 8	60	5,2	II
398522763200	SWKB Z400-30-12	18	30	50	71	33	M 8	60	4,6	II
398522763200	SWKB Z400-30-12	18	30	50	71	33	M 8	60	4,6	I
398522760400	SWKB Z315-26-21	12	26	40	53	25	M 8	54	3,1	II
398522761700	SWKB Z315-26-24	12	26	40	53	25	M 8	54	2,8	II
398522761700	SWKB Z315-26-24	12	26	40	53	25	M 8	54	2,8	I
398522760400	SWKB Z315-26-21	12	26	40	53	25	M 8	54	2,8	II
398522762000	SWKB Z400-30-09	18	30	50	71	33	M 8	60	5,2	II
398522763200	SWKB Z400-30-12	18	30	50	71	33	M 8	60	4,6	II
398522763200	SWKB Z400-30-12	18	30	50	71	33	M 8	60	4,6	I
398522762000	SWKB Z400-30-09	18	30	50	71	33	M 8	60	5,2	II
398522763200	SWKB Z400-30-12	18	30	50	71	33	M 8	60	4,6	II
398522763200	SWKB Z400-30-12	18	30	50	71	33	M 8	60	4,6	I
398522762000	SWKB Z400-30-09	18	30	50	71	33	M 8	60	5,2	II
398522763200	SWKB Z400-30-12	18	30	50	71	33	M 8	60	4,6	II
398522763200	SWKB Z400-30-12	18	30	50	71	33	M 8	60	4,6	I
398522760400	SWKB Z315-26-21	12	26	40	53	25	M 8	54	3,1	I
398522761700	SWKB Z315-26-24	12	26	40	53	25	M 8	54	2,8	II
398522762000	SWKB Z400-30-09	18	30	50	71	33	M 8	60	5,2	II
398522763200	SWKB Z400-30-12	18	30	50	71	33	M 8	60	4,6	II
398522763200	SWKB Z400-30-12	18	30	50	71	33	M 8	60	4,6	I
398522762000	SWKB Z400-30-09	18	30	50	71	33	M 8	60	5,2	II
398522763200	SWKB Z400-30-12	18	30	50	71	33	M 8	60	4,6	II
398522763200	SWKB Z400-30-12	18	30	50	71	33	M 8	60	4,6	I
398522762000	SWKB Z400-30-09	18	30	50	71	33	M 8	60	5,2	II
398522763200	SWKB Z400-30-12	18	30	50	71	33	M 8	60	4,6	II
398522763200	SWKB Z400-30-12	18	30	50	71	33	M 8	60	4,6	I
398522762000	SWKB Z400-30-09	18	30	50	71	33	M 8	60	5,2	II
398522763200	SWKB Z400-30-12	18	30	50	71	33	M 8	60	4,6	II
398522763200	SWKB Z400-30-12	18	30	50	71	33	M 8	60	4,6	I

Ø 400 - 500 mm



Kołki опорowe str. 503  
 Опорные шпильки стр.

SWKB Z

Dystrybucja: unihurt.pl



Zamówienia: info@unihurt.pl



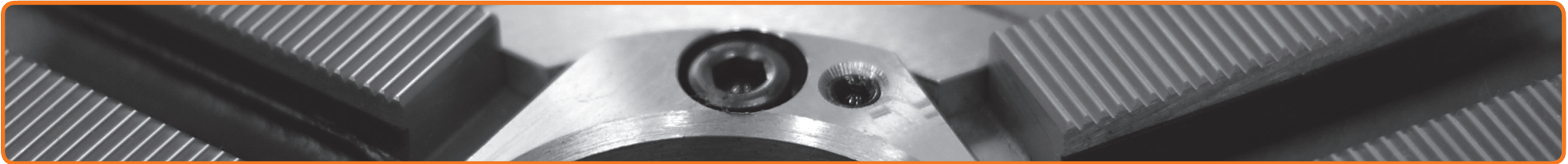

Ø 400 - 500 mm	SCHUNK			FORKARDT			RÖHM			SMW-AUTOBLOK			BERG		
	Zakres mocowania	Max. wysięg szczęk	Typ uchwytu	Zakres mocowania	Max. wysięg szczęk	Typ uchwytu	Zakres mocowania	Max. wysięg szczęk	Typ uchwytu	Zakres mocowania	Max. wysięg szczęk	Typ uchwytu	Zakres mocowania	Max. wysięg szczęk	Typ uchwytu
	Диапазон зажима	Макс. вылет кулачков	Тип патрона	Диапазон зажима	Макс. вылет кулачков	Тип патрона	Диапазон зажима	Макс. вылет кулачков	Тип патрона	Диапазон зажима	Макс. вылет кулачков	Тип патрона	Диапазон зажима	Макс. вылет кулачков	Тип патрона
							59 - 160	498	DURO 400						
							139 - 244	481	DURO 400						
							241 - 380	498	DURO 400						
							64 - 164	502	DURO-NC 400	66 - 149	487	HG-F 400			
							145 - 265	502	DURO-NC 400	131 - 250	487	HG-F 400			
							247 - 384	502	DURO-NC 400	214 - 367	485	HG-F 400			
	159 - 225	445	ROTA-G 400										55 - 108	375	KHNC 400
	50 - 178	445	ROTA-G 400	58 - 154	420	KTNC 400	90 - 199	466	DURO-NCE 400	62 - 144	411	HG-N 400	87 - 183	373	KHNC 400
	212 - 286	453	ROTA-G 400	152 - 262	420	KTNC 400	197 - 307	466	DURO-NCE 400	136 - 263	422	HG-N 400	148 - 242	402	KHNC 400
	267 - 364	453	ROTA-G 400	214 - 341	430	KTNC 400	275 - 385	474	DURO-NCE 400	213 - 341	430	HG-N 400	238 - 374	454	KHNC 400
				54 - 158	426	KTNCV 400				49 - 154	421	KNCS 400			
				160 - 262	420	KTNCV 400				143 - 251	410	KNCS 400			
				214 - 370	458	KTNCV 400				220 - 340	429	KNCS 400			
	51 - 168	507	ROTA-S plus 400				54 - 180	329	DURO-NCES 400						
	119 - 266	509	ROTA-S plus 400				134 - 282	519	DURO-NCES 400						
	230 - 382	509	ROTA-S plus 400				253 - 401	519	DURO-NCES 400						
	44 - 154	435	ROTA THW 400	58 - 181	448	FNC 400	53 - 181	449	DURO-NCES 400	63 - 181	449	KNCS-N 400			
	134 - 262	433	ROTA THW 400	135 - 289	448	FNC 400	158 - 290	449	DURO-NCES 400	169 - 290	449	KNCS-N 400			
	211 - 340	429	ROTA THW 400	200 - 355	444	FNC 400	236 - 368	457	DURO-NCES 400	256 - 368	457	KNCS-N 400			
	54 - 196	532	ROTA-G 500	80 - 154	485	F 500 L	61 - 213	552	DURO 500	66 - 166	504	HG-F 500			
	153 - 337	574	ROTA-G 500	146 - 285	520	F 500 L	175 - 314	552	DURO 500	147 - 267	504	HG-F 500			
	270 - 452	570	ROTA-G 500	282 - 448	566	F 500 L	277 - 451	569	DURO 500	266 - 402	520	HG-F 500			
	66 - 196	532	ROTA-S plus 500	80 - 154	485	F+ 500 L	60 - 193	532	DURO-NC 500	67 - 180	518	HG-N 500			
	162 - 328	575	ROTA-S plus 500	142 - 293	525	F+ 500 L	174 - 294	532	DURO-NC 500	138 - 267	504	HG-N 500			
	288 - 465	585	ROTA-S plus 500	248 - 460	588	F+ 500 L	259 - 431	549	DURO-NC 500	245 - 402	520	HG-N 500			
	55 - 177	520	ROTA THW 500	80 - 179	518	KTNC 500				71 - 179	518	KNCS 500			
	145 - 279	520	ROTA THW 500	140 - 280	518	KTNC 500				155 - 281	518	KNCS 500			
	265 - 400	520	ROTA THW 500	245 - 400	518	KTNC 500				260 - 400	518	KNCS 500			
				80 - 230	569	KTNCV 500				58 - 207	546	KNCS-N 500			
				143 - 284	530	KTNCV 500				141 - 309	546	KNCS-N 500			
				261 - 451	569	KTNCV 500				260 - 430	548	KNCS-N 500			
				80 - 164	578	FNC 500									
				153 - 330	578	FNC 500									
				269 - 448	576	FNC 500									

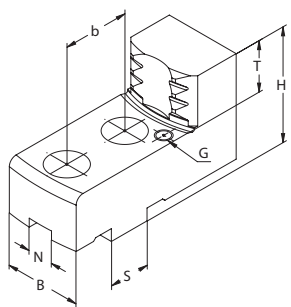

**SZCZĘKI CHWYTAKOWE - MOCOWANIE ZEWNĘTRZNE**

КУЛАЧКИ ЗУБЧАТЫЕ - ВНЕШНИЙ ЗАЖИМ

**Z WPUSTEM I ROWKIEM**

С СИСТЕМОЙ ПАЗ-ШПОНКА

Możliwość regulacji głębokości mocowania przedmiotu obrabianego „T”, za pomocą wymiennych kołków опорowych.

Śruby nie wchodzi w zakres dostawy i muszą być zamawiane oddzielnie.

Возможность регулировки глубины крепления обрабатываемой детали «Т» при помощи съемных опорных шпилек.

Эти шпильки не входят в комплект поставки и должны быть заказаны отдельно.

**Pozycja szczęk podstawowych**  
 Положение мастер кулачков

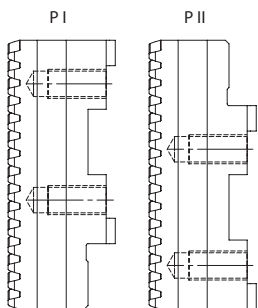

Oś BISON  
 Ось BISON

**Kółki опорowe** str. 503  
 Опорные шпильки стр.

Nr produktu	Typ szczęk	N	S	B	H	T	G	b	kg / kpl.	Pozycja szczęk podstawowych
Код продукта	Тип кулачков								кг / кпл.	Положение мастер кулачков
398522638000	SZKB Z160-18-67	8	18	26	40	20	M 6	32	0,7	I
398522639200	SZKB Z160-18-68	8	18	26	40	20	M 6	32	0,8	II
398522640000	SZKB Z160-18-69	8	18	30	40	20	M 6	32	0,8	II
398522640000	SZKB Z160-18-69	8	18	30	40	20	M 6	32	0,8	I
398522639200	SZKB Z160-18-68	8	18	26	40	20	M 6	32	0,8	I
398522640000	SZKB Z160-18-69	8	18	30	40	20	M 6	32	0,8	I
398522638000	SZKB Z160-18-67	8	18	26	40	20	M 6	32	0,7	I
398522639200	SZKB Z160-18-68	8	18	26	40	20	M 6	32	0,8	I
398522640000	SZKB Z160-18-69	8	18	30	40	20	M 6	32	0,8	II
398522640000	SZKB Z160-18-69	8	18	30	40	20	M 6	32	0,8	I
398522638000	SZKB Z160-18-67	8	18	26	40	20	M 6	32	0,7	I
398522639200	SZKB Z160-18-68	8	18	26	40	20	M 6	32	0,8	I
398522640000	SZKB Z160-18-69	8	18	30	40	20	M 6	32	0,8	II
398522640000	SZKB Z160-18-69	8	18	30	40	20	M 6	32	0,8	I
398522638000	SZKB Z160-18-67	8	18	26	40	20	M 6	32	0,7	I
398522639200	SZKB Z160-18-68	8	18	26	40	20	M 6	32	0,8	I
398522640000	SZKB Z160-18-69	8	18	30	40	20	M 6	32	0,8	II
398522640000	SZKB Z160-18-69	8	18	30	40	20	M 6	32	0,8	I
398522638000	SZKB Z160-18-67	8	18	26	40	20	M 6	32	0,7	I
398522639200	SZKB Z160-18-68	8	18	26	40	20	M 6	32	0,8	I
398522640000	SZKB Z160-18-69	8	18	30	40	20	M 6	32	0,8	II
398522640000	SZKB Z160-18-69	8	18	30	40	20	M 6	32	0,8	I
398522641200	SZKB Z200-20-09	10	20	30	45	20	M 6	40	1,3	I
398522642500	SZKB Z200-20-11	10	20	30	45	20	M 6	40	1,1	II
398522642500	SZKB Z200-20-11	10	20	30	45	20	M 6	40	1,1	I
398522641200	SZKB Z200-20-09	10	20	30	45	20	M 6	40	1,3	I
398522642500	SZKB Z200-20-11	10	20	30	45	20	M 6	40	1,1	II
398522642500	SZKB Z200-20-11	10	20	30	45	20	M 6	40	1,1	I
398522642500	SZKB Z200-20-11	10	20	30	45	20	M 6	40	1,1	II
398522641200	SZKB Z200-20-09	10	20	30	45	20	M 6	40	1,3	I
398522642500	SZKB Z200-20-11	10	20	30	45	20	M 6	40	1,1	II
398522642500	SZKB Z200-20-11	10	20	30	45	20	M 6	40	1,1	I
398522641200	SZKB Z200-20-09	10	20	30	45	20	M 6	40	1,3	I
398522642500	SZKB Z200-20-11	10	20	30	45	20	M 6	40	1,1	II
398522642500	SZKB Z200-20-11	10	20	30	45	20	M 6	40	1,1	I
398522641200	SZKB Z200-20-09	10	20	30	45	20	M 6	40	1,3	I
398522642500	SZKB Z200-20-11	10	20	30	45	20	M 6	40	1,1	II
398522642500	SZKB Z200-20-11	10	20	30	45	20	M 6	40	1,1	I

Ø 160 - 200 mm

Distybuycja: unihurt.pl



Zamówienia: info@unihurt.pl

1  
2  
3  
4  
5  
6

7  
C

SZKB Z

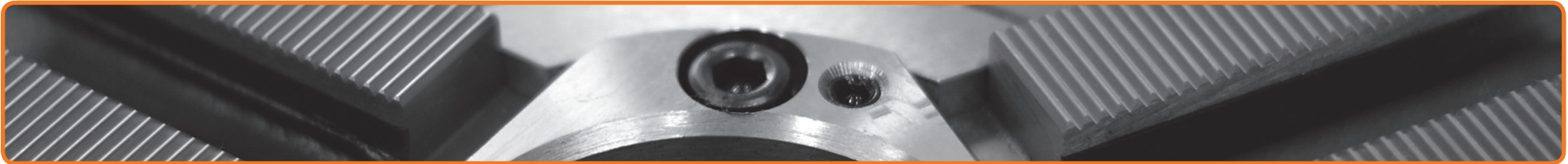

Ø 160 - 200 mm	SCHUNK			FORKARDT			RÖHM			SMW-AUTOBLOK			BERG		
	Zakres mocowania	Max. wysięg szczęk	Typ uchwytu	Zakres mocowania	Max. wysięg szczęk	Typ uchwytu	Zakres mocowania	Max. wysięg szczęk	Typ uchwytu	Zakres mocowania	Max. wysięg szczęk	Typ uchwytu	Zakres mocowania	Max. wysięg szczęk	Typ uchwytu
	Диапазон зажима	Макс. вылет кулачков	Тип патрона	Диапазон зажима	Макс. вылет кулачков	Тип патрона	Диапазон зажима	Макс. вылет кулачков	Тип патрона	Диапазон зажима	Макс. вылет кулачков	Тип патрона	Диапазон зажима	Макс. вылет кулачков	Тип патрона
										47 - 72	193	HG-F 160	47 - 76	197	KHNC 160
	55 - 92	207	ROTA-G 160												
	75 - 129	207	ROTA-G 160							67 - 97	193	HG-F 160	72 - 107	205	KHNC 160
	92 - 147	207	ROTA-G 160							97 - 132	193	HG-F 160	100 - 136	197	KHNC 160
	51 - 101	217	ROTA-S plus 160												
	101 - 156	217	ROTA-S plus 160												
	46 - 57	177	THW 165-R							46 - 71	192	HG-N 160			
	52 - 62	177	THW 165-R												
	67 - 99	177	THW 165-R							69 - 112	191	HG-N 160			
	84 - 117	177	THW 165-R							96 - 131	192	HG-N 160			
										46 - 65	186	KNCS 175			
	55 - 73	190	ROTA THW plus 165							51 - 71	186	KNCS 175			
	74 - 110	190	ROTA THW plus 165							73 - 108	186	KNCS 175			
	83 - 128	190	ROTA THW plus 165							91 - 126	186	KNCS 175			
	54 - 90		ROTA THW plus 185							47 - 71	192	KNCS-N 170	55 - 100	222	KHNC 185
										53 - 77	192	KNCS-N 170			
	86 - 150	212	ROTA THW plus 185							78 - 114	192	KNCS-N 170	86 - 132	229	KHNC 185
	53 - 124	212	ROTA-G 200	55 - 90	241	F 200	57 - 95	246	DURO 200	53 - 86	237	HG-F 210	115 - 160	222	KHNC 185
				87 - 127	252	F 200	83 - 135	265	DURO 200	83 - 117	237	HG-F 210	86 - 121	251	KHNC 200
	120 - 194	276	ROTA-G 200	125 - 170	251	F 200	117 - 174	256	DURO 200	99 - 155	237	HG-F 210	120 - 165	239	KHNC 200
	53 - 115	276	ROTA-S plus 200	53 - 111	263	F+ 200	62 - 120	271	DURO-NC 200	53 - 88	240	HG-N 210			
	83 - 137	267	ROTA-S plus 200	83 - 134	263	F+ 200	84 - 161	291	DURO-NC 200	83 - 120	240	HG-N 210			
	119 - 185	267	ROTA-S plus 200	115 - 181	263	F+ 200	112 - 190	271	DURO-NC 200	104 - 158	240	HG-N 210			
	53 - 96	248	THW 210-R	53 - 90	241	KTNC 200	53 - 95	246	DURO-NCE 200	58 - 84	236	KNCS 200			
	84 - 128	250	THW 210-R	83 - 112	241	KTNC 200	83 - 117	246	DURO-NCE 200	83 - 117	236	KNCS 200			
	113 - 166	248	THW 210-R	122 - 160	241	KTNC 200	118 - 174	256	DURO-NCE 200	109 - 154	236	KNCS 200			
	53 - 111	264	ROTA THW plus 215	54 - 111	263	KTNCV 200	53 - 129	281	DURO-NCES 200	53 - 115	267	KNCS-N 210			
				84 - 133	263	KTNCV 200				93 - 147	267	KNCS-N 210			
	106 - 181	264	ROTA THW plus 215	123 - 181	263	KTNCV 200	111 - 199	281	DURO-NCES 200	112 - 185	267	KNCS-N 210			
				54 - 111	263	FNC 200	53 - 115	267	DURO-NCES 200						
				83 - 133	263	FNC 200									
				124 - 181	263	FNC 200	110 - 185	267	DURO-NCES 200						





1  
2  
3  
4  
5  
6  
7  
C

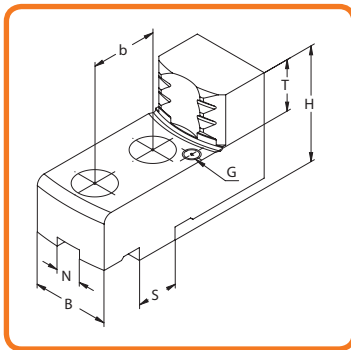

**SZCZĘKI CHWYTAKOWE - MOCOWANIE ZEWNĘTRZNE**  
 КУЛАЧКИ ЗУБЧАТЫЕ - ВНЕШНИЙ ЗАЖИМ

**Z WPUSTEM I ROWKIEM**  
 С СИСТЕМОЙ ПАЗ-ШПОНКА

- Możliwość regulacji głębokości mocowania przedmiotu obrabianego „T”, za pomocą wymiennych kołków опорowych.
- Śruby nie wchodzą w zakres dostawy i muszą być zamawiane oddzielnie.
- Возможность регулировки глубины крепления обрабатываемой детали «Т» при помощи съемных опорных шпилек.
- Эти шпильки не входят в комплект поставки и должны быть заказаны отдельно.

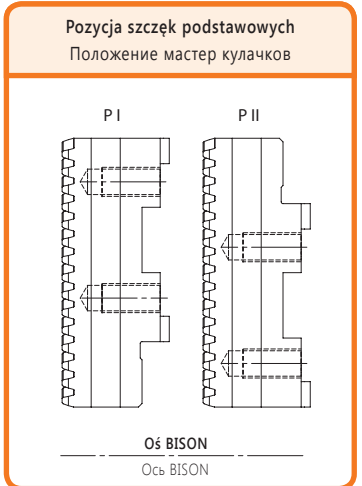

**Kołki опорowe** str. 503  
 Опорные шпильки стр.

Nr produktu	Typ szczęk	N	S	B	H	T	G	b	kg / kpl.	Pozycja szczęk podstawowych
									kg / kpl.	Положение мастер кулачков
398522643800	SZKB Z250-20-61	12	20	40	50	25	M 6	40	2,1	I
398522644000	SZKB Z250-20-64	12	20	40	50	25	M 6	40	1,9	II
398522644000	SZKB Z250-20-64	12	20	40	50	25	M 6	40	1,9	I
398522643800	SZKB Z250-20-61	12	20	40	50	25	M 6	40	2,1	I
398522644000	SZKB Z250-20-64	12	20	40	50	25	M 6	40	1,9	II
398522644000	SZKB Z250-20-64	12	20	40	50	25	M 6	40	1,9	I
398522643800	SZKB Z250-20-61	12	20	40	50	25	M 6	40	2,1	I
398522644000	SZKB Z250-20-64	12	20	40	50	25	M 6	40	1,9	II
398522644000	SZKB Z250-20-64	12	20	40	50	25	M 6	40	1,9	I
398522643800	SZKB Z250-20-61	12	20	40	50	25	M 6	40	2,1	I
398522644000	SZKB Z250-20-64	12	20	40	50	25	M 6	40	1,9	I
398522644000	SZKB Z250-20-64	12	20	40	50	25	M 6	40	1,9	II
398522645300	SZKB Z315-26-19	12	26	40	53	25	M 8	54	2,9	I
398522646600	SZKB Z315-26-22	12	26	40	53	25	M 8	54	2,3	II
398522646600	SZKB Z315-26-22	12	26	40	53	25	M 8	54	2,3	I
398522645300	SZKB Z315-26-19	12	26	40	53	25	M 8	54	2,9	I
398522646600	SZKB Z315-26-22	12	26	40	53	25	M 8	54	2,3	I
398522643800	SZKB Z250-20-61	12	20	40	50	25	M 6	40	2,1	I
398522644000	SZKB Z250-20-64	12	20	40	50	25	M 6	40	1,9	II
398522644000	SZKB Z250-20-64	12	20	40	50	25	M 6	40	1,9	I
398522645300	SZKB Z315-26-19	12	26	40	53	25	M 8	54	2,9	I
398522646600	SZKB Z315-26-22	12	26	40	53	25	M 8	54	2,3	II
398522646600	SZKB Z315-26-22	12	26	40	53	25	M 8	54	2,3	I
398522643800	SZKB Z250-20-61	12	20	40	50	25	M 6	40	2,1	I
398522644000	SZKB Z250-20-64	12	20	40	50	25	M 6	40	1,9	II
398522644000	SZKB Z250-20-64	12	20	40	50	25	M 6	40	1,9	I
398522643800	SZKB Z250-20-61	12	20	40	50	25	M 6	40	2,1	I
398522644000	SZKB Z250-20-64	12	20	40	50	25	M 6	40	1,9	II
398522644000	SZKB Z250-20-64	12	20	40	50	25	M 6	40	1,9	I

Dystrybucja: unihurt.pl  
 Zamówienia: info@unihurt.pl

SZKB Z



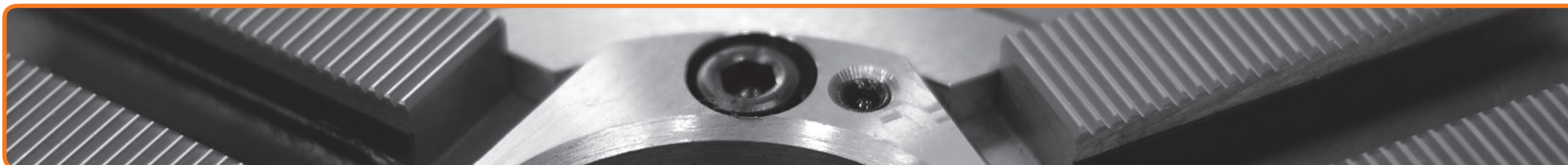

Ø 250 - 315 mm	SCHUNK			FORKARDT			RÖHM			SMW-AUTOBLOK			BERG		
	Zakres mocowania	Max. wysięg szczęk	Typ uchwytu	Zakres mocowania	Max. wysięg szczęk	Typ uchwytu	Zakres mocowania	Max. wysięg szczęk	Typ uchwytu	Zakres mocowania	Max. wysięg szczęk	Typ uchwytu	Zakres mocowania	Max. wysięg szczęk	Typ uchwytu
	Диапазон зажима	Макс. вылет кулачков	Тип патрона	Диапазон зажима	Макс. вылет кулачков	Тип патрона	Диапазон зажима	Макс. вылет кулачков	Тип патрона	Диапазон зажима	Макс. вылет кулачков	Тип патрона	Диапазон зажима	Макс. вылет кулачков	Тип патрона
	69 - 158	330	ROTA-G 250	80 - 134	304	F 250	76 - 143	315	DURO 250	69 - 124	294	HG-F 260	80 - 134	304	KHNC 250
	124 - 220	334	ROTA-G 250	123 - 198	328	F 250	118 - 199	326	DURO 250	110 - 168	295	HG-F 260	126 - 180	309	KHNC 250
	181 - 274	336	ROTA-G 250	198 - 246	305	F 250	193 - 263	317	DURO 250	173 - 242	296	HG-F 260	186 - 230	298	KHNC 250
	71 - 151	322	ROTA-S plus 250	69 - 148	320	F+ 250	83 - 153	324	DURO-NC 250	69 - 124	295	HG-N 260			
	113 - 192	309	ROTA-S plus 250	112 - 186	320	F+ 250	125 - 208	336	DURO-NC 250	108 - 180	295	HG-N 260			
	188 - 270	311	ROTA-S plus 250	186 - 262	322	F+ 250	189 - 260	314	DURO-NC 250	168 - 243	297	HG-N 260			
	69 - 126	297	THW 250-R	80 - 136	307	KTNC 250	80 - 137	308	DURO-NCE 250	69 - 121	292	KNCS 250			
	119 - 181	297	THW 250-R	122 - 180	307	KTNC 250	123 - 181	308	DURO-NCE 250	114 - 178	293	KNCS 250			
	182 - 245	299	THW 250-R	197 - 255	309	KTNC 250	198 - 256	310	DURO-NCE 250	176 - 240	294	KNCS 250			
	76 - 140	313	ROTA THW plus 260	77 - 158	330	KTNCV 250	71 - 165	336	DURO-NCES 250	69 - 143	314	KNCS-N 260			
	120 - 196	313	ROTA THW plus 260	120 - 203	326	KTNCV 250	114 - 209	336	DURO-NCES 250	114 - 199	314	KNCS-N 260			
	183 - 259	315	ROTA THW plus 260	195 - 278	332	KTNCV 250	189 - 284	338	DURO-NCES 250	177 - 262	316	KNCS-N 260			
	89 - 208	381	ROTA-G 315	77 - 158	330	FNC 250	78 - 143	314	DURO-NCES 250						
	207 - 328	383	ROTA-G 315	195 - 278	332	FNC 250	112 - 199	314	DURO-NCES 250						
				120 - 202	330	FNC 250	175 - 262	316	DURO-NCES 250						
	92 - 208	400	ROTA-S plus 315	102 - 168	358	F 315	95 - 179	370	DURO 315	92 - 191	382	HG-F 315			
	117 - 239	400	ROTA-S plus 315	144 - 230	402	F 315	138 - 224	384	DURO 315	124 - 208	382	HG-F 315			
	191 - 317	400	ROTA-S plus 315	210 - 282	370	F 315	202 - 301	384	DURO 315	187 - 299	382	HG-F 315			
				92 - 192	384	F+ 315	101 - 200	391	DURO-NC 315						
				189 - 293	384	F+ 315	195 - 322	405	DURO-NC 315						
	93 - 176	348	THW 315-R	80 - 160	331	KTNC 315	97 - 166	338	DURO-NCE 315	91 - 181	353	HG-N 315	80 - 134	304	KHNC 315
	124 - 208	346	THW 315-R	122 - 203	331	KTNC 315	152 - 222	350	DURO-NCE 315	123 - 213	351	HG-N 315	112 - 180	309	KHNC 315
	211 - 295	350	THW 315-R	197 - 279	333	KTNC 315	216 - 309	364	DURO-NCE 315	210 - 300	355	HG-N 315	184 - 278	334	KHNC 315
							105 - 200	391	DURO-NCES 315						
							135 - 231	391	DURO-NCES 315						
							212 - 309	391	DURO-NCES 315						
	89 - 197	371	ROTA THW PLUS 315	77 - 194	366	KTNCC 315	101 - 198	370	DURO-NCES 315	91 - 165	337	KNCS 315			
	124 - 234	373	ROTA THW PLUS 315	120 - 238	366	KTNCC 315	129 - 227	370	DURO-NCES 315	122 - 208	346	KNCS 315			
	207 - 317	373	ROTA THW PLUS 315	195 - 314	368	KTNCC 315	219 - 318	372	DURO-NCES 315	109 - 295	350	KNCS 315			
				77 - 194	366	FNC 315									
										92 - 187	359	KNCS-N 315			
										134 - 230	368	KNCS-N 315			
				195 - 313	368	FNC 315				220 - 318	372	KNCS-N 315			

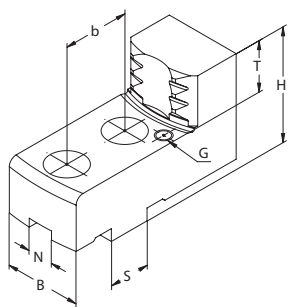

**SZCZĘKI CHWYTAKOWE - MOCOWANIE ZEWNĘTRZNE**

КУЛАЧКИ ЗУБЧАТЫЕ - ВНЕШНИЙ ЗАЖИМ

**Z WPUSTEM I ROWKIEM**

С СИСТЕМОЙ ПАЗ-ШПОНКА

- Możliwość regulacji głębokości mocowania przedmiotu obrabianego „T”, za pomocą wymiennych kołków опорowych.
- Śruby nie wchodzą w zakres dostawy i muszą być zamawiane oddzielnie.
- Возможность регулировки глубины крепления обрабатываемой детали «Т» при помощи съемных опорных шпилек.
- Эти шпильки не входят в комплект поставки и должны быть заказаны отдельно.

**Pozycja szczęk podstawowych**  
Положение мастер кулачков

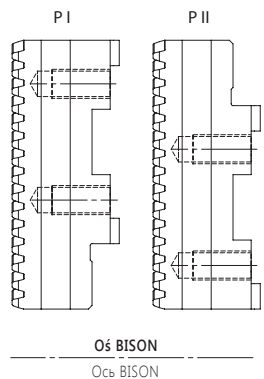

Nr produktu	Typ szczęk	N	S	B	H	T	G	b	kg / kpl.	Pozycja szczęk podstawowych
									кг / кпл.	Положение мастер кулачков
398522645300	SZKB Z315-26-09	12	26	40	53	25	M 8	54	3,9	I
398522646600	SZKB Z315-26-22	12	26	40	53	25	M 8	54	2,7	I
398522647900	SZKB Z400-30-09	18	30	60	71	33	M 8	60	6,0	II
398522648100	SZKB Z400-30-11	18	30	50	71	33	M 8	60	5,5	II
398522648100	SZKB Z400-30-11	18	30	50	71	33	M 8	60	5,5	I
398522647900	SZKB Z400-30-09	18	30	60	71	33	M 8	60	6,0	II
398522648100	SZKB Z400-30-11	18	30	50	71	33	M 8	60	5,5	II
398522648100	SZKB Z400-30-11	18	30	50	71	33	M 8	60	5,5	I
398522645300	SZKB Z315-26-09	12	26	40	53	25	M 8	54	3,9	I
398522646600	SZKB Z315-26-22	12	26	40	53	25	M 8	54	2,7	I
398522646600	SZKB Z315-26-22	12	26	40	53	25	M 8	54	2,7	II
398522645300	SZKB Z315-26-09	12	26	40	53	25	M 8	54	2,7	I
398522646600	SZKB Z315-26-22	12	26	40	53	25	M 8	54	3,9	I
398522646600	SZKB Z315-26-22	12	26	40	53	25	M 8	54	2,7	II
398522647900	SZKB Z400-30-09	18	30	60	71	33	M 8	60	6,0	II
398522648100	SZKB Z400-30-11	18	30	50	71	33	M 8	60	5,5	II
398522648100	SZKB Z400-30-11	18	30	50	71	33	M 8	60	5,5	I
398522645300	SZKB Z315-26-09	12	26	40	53	25	M 8	54	3,9	I
398522646600	SZKB Z315-26-22	12	26	40	53	25	M 8	54	2,7	I
398522647900	SZKB Z400-30-09	18	30	60	71	33	M 8	60	6,0	II
398522648100	SZKB Z400-30-11	18	30	50	71	33	M 8	60	5,5	II
398522648100	SZKB Z400-30-11	18	30	50	71	33	M 8	60	5,5	I
398522647900	SZKB Z400-30-09	18	30	60	71	33	M 8	60	6,0	II
398522648100	SZKB Z400-30-11	18	30	50	71	33	M 8	60	5,5	II
398522648100	SZKB Z400-30-11	18	30	50	71	33	M 8	60	5,5	I

Ø 315 - 400 mm

**Kołki опорowe** str. 503  
Опорные шпильки стр.

Dystrybucja: unihurt.pl  
Zamówienia: info@unihurt.pl

SZKB Z

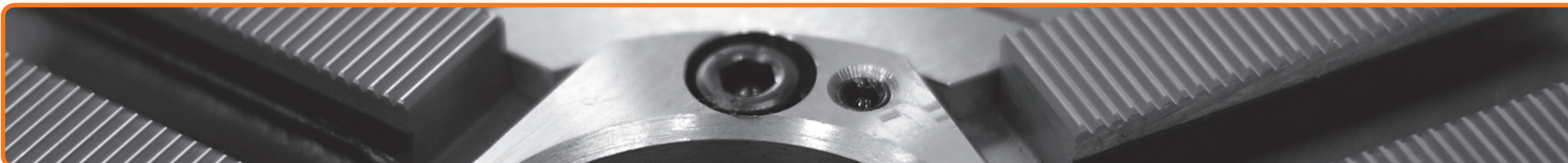

Ø 315 - 400 mm	SCHUNK			FORKARDT			RÖHM			SMW-AUTOBLOK			BERG		
	Zakres mocowania	Max. wysięg szczęk	Typ uchwytu	Zakres mocowania	Max. wysięg szczęk	Typ uchwytu	Zakres mocowania	Max. wysięg szczęk	Typ uchwytu	Zakres mocowania	Max. wysięg szczęk	Typ uchwytu	Zakres mocowania	Max. wysięg szczęk	Typ uchwytu
	Диапазон зажима	Макс. вылет кулачков	Тип патрона	Диапазон зажима	Макс. вылет кулачков	Тип патрона	Диапазон зажима	Макс. вылет кулачков	Тип патрона	Диапазон зажима	Макс. вылет кулачков	Тип патрона	Диапазон зажима	Макс. вылет кулачков	Тип патрона
	127 - 240	430	ROTA-G 400												
	236 - 360	444	ROTA-G 400												
	103 - 199	507	ROTA-S plus 400	117 - 190	409	F 400	119 - 191	503	DURO 400						
	156 - 289	507	ROTA-S plus 400	150 - 285	510	F 400	177 - 279	503	DURO 400						
	254 - 409	507	ROTA-S plus 400	270 - 400	504	F 400	262 - 399	504	DURO 400						
				108 - 192	510	F+ 400	114 - 178	489	DURO-NC 400						
				150 - 285	510	F+ 400	169 - 277	489	DURO-NC 400	88 - 200	487	HG-F 400			
				270 - 400	505	F+ 400	270 - 403	508	DURO-NC 400	198 - 317	485	HG-F 400			
	102 - 229	421	THW 400-R	105 - 230	422	KTNC 400	165 - 274	466	DURO-NCE 400	114 - 230	422	HG-N 400	98 - 181	373	KHNC 400
	210 - 338	421	THW 400-R	212 - 340	422	KTNC 400	273 - 383	466	DURO-NCE 400	211 - 339	422	HG-N 400	208 - 358	430	KHNC 400
										134 - 261	422	HG-N 400	146 - 268	440	KHNC 400
				104 - 258	450	KTNCV 400				100 - 196	388	KNCS 400			
				212 - 367	450	KTNCV 400				208 - 338	421	KNCS 400			
										131 - 260	421	KNCS 400			
				92 - 244	436	FNC 400				126 - 257	449	KNCS-N 400			
				199 - 353	436	FNC 400				237 - 366	449	KNCS-N 400			
										157 - 288	449	KNCS-N 400			
	110 - 255	568	ROTA-G 500	111 - 193	501	F 500 L	116 - 202	521	DURO-NCES 400						
	175 - 345	568	ROTA-G 500	194 - 292	504	F 500 L	171 - 300	521	DURO-NCES 400						
	290 - 470	568	ROTA-G 500	293 - 472	564	F 500 L	274 - 403	505	DURO-NCES 400						
							126 - 256	449	DURO-NCES 400						
							223 - 366	449	DURO-NCES 400						
	108 - 274	580	ROTA-S plus 500	111 - 280	592	F+ 500 L									
	190 - 360	580	ROTA-S plus 500												
	288 - 478	580	ROTA-S plus 500	216 - 421	576	F+ 500 L									
	106 - 209	519	ROTA THW 500	103 - 210	522	KTNC 500									
	165 - 298	519	ROTA THW 500	166 - 298	522	KTNC 500									
	285 - 420	519	ROTA THW 500	275 - 415	522	KTNC 500									
				109 - 261	572	KTNCV 500									
				160 - 300	572	KTNCV 500									
				291 - 469	572	KTNCV 500									

- 1
- 2
- 3
- 4
- 5
- 6

7

Dystrybucja: unihurt.pl



Zamówienia: info@unihurt.pl IKZS

- 1
- 2
- 3
- 4
- 5
- 6
- 7
- C

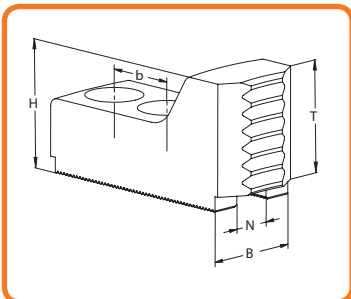

**SZCZĘKI CHWYTAKOWE DO MOCOWANIA WAŁKÓW**  
 КУЛАЧКИ ЗУБЧАТЫЕ ДЛЯ ЗАЖИМА ВАЛОВ

**METRYCZNA WIELKOŚĆ KĄTA ZĄBKÓW 1,5 mm x 60°**  
 МЕТРИЧЕСКОЕ ЗУБЧАТОЕ СОЕДИНЕНИЕ 1,5 мм x 60°



Nr produktu Код продукта	Typ szczęk Тип кулачков	N	B	H	T	b	Śruby	kg / kpl.
							Винты	кг / кпл.
398522649400	SWKB-B M160-12-02	12	30	40	34	20	M 10	1,1
398522650100	SWKB-B M200-14-02	14	35	45	39,5	25	M 12	1,8
398522651400	SWKB-B M250-16-03	16	40	50	40	30	M 12	2,5
398522653000	SWKB-B M315-18-01	18	50	50	40	30	M 14	3,5
398522652700	SWKB-B M315-21-03	21	50	50	40	30	M 16	3,5

Ø 165 - 315 mm



**Wkładki teowe**  
 Т-образные вкладки str. 492-501  
 Материал кулачков стр.



Материал szczęk  
 Материал кулачков



Wielkość kąta ząbków  
 Зубчатое соединение

Dystrybucja: unihurt.pl  
 Zamówienia: info@unihurt.pl



Zamówienia: info@unihurt.pl

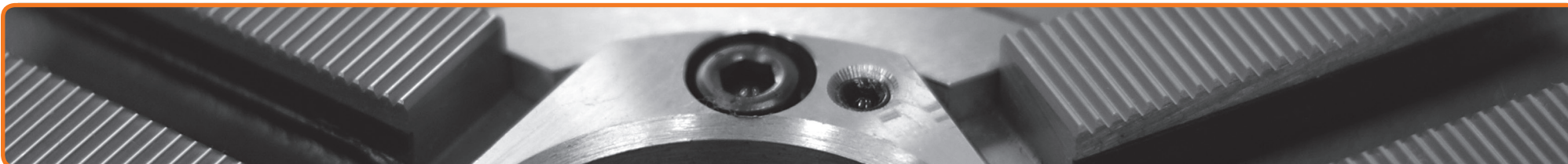

Ø 165 - 315 mm	SCHUNK			KITAGAWA			SMW-AUTOBLOK			HOWA		
	Zakres mocowania	Max. wysięg szczęk	Typ uchwytu	Zakres mocowania	Max. wysięg szczęk	Typ uchwytu	Zakres mocowania	Max. wysięg szczęk	Typ uchwytu	Zakres mocowania	Max. wysięg szczęk	Typ uchwytu
	Диапазон зажима	Макс. вылет кулачков	Тип патрона	Диапазон зажима	Макс. вылет кулачков	Тип патрона	Диапазон зажима	Макс. вылет кулачков	Тип патрона	Диапазон зажима	Макс. вылет кулачков	Тип патрона
	13 - 32	171	ROTA NCK (plus) 165	14 - 29	168	B 160; B 6; BB 06	14 - 39	178	AN-M 165	13 - 38	175	HO 7 MA 6
				14 - 31	170	B 206; HOH 6						
				14 - 25	163	HOH 160; N 6						
				14 - 31	170	HOH 206; N 160						
				17 - 34	173	BB 06; BB 206						
	17 - 41	213	ROTA NCK (plus) 210	17 - 38	210	B 200; B 8	15 - 48	221	AN-M 210	12 - 51	224	HO 7 MA 8
				17 - 41	213	B 208; HOH 8						
				17 - 41	213	HOH 200; N 8						
				17 - 41	213	HOH 208; N 200						
				21 - 43	215	BB 08; BB 208						
	21 - 59	258	ROTA NCK (plus) 250	17 - 57	256	B 250; B 10	21 - 59	258	AN-M 250	20 - 58	257	BH-M 250
				17 - 59	258	B 210; HOH 10						
				17 - 53	252	HOH 250; N 10						
				17 - 54	253	HOH 10 K; N 250						
				27 - 52	251	BB 10; BB 210						
			20 - 81	304	B 300; B 12							
			22 - 79	302	HOH 300							
			20 - 87	310	HOH 12; N 12							
			20 - 81	304	HOH 12 K; N 300							
23 - 80	303	ROTA NCK (plus) 315	22 - 82	305	B 212	20 - 97	320	AN-M 315	27 - 97	320	BH-M 315	
			33 - 93	315	BB 212							
												57 - 96

- 1
- 2
- 3
- 4
- 5
- 6
- 7
- C

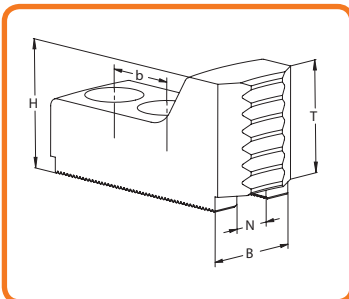

**SZCZĘKI CHWYTAKOWE DO MOCOWANIA WAŁKÓW**

КУЛАЧКИ ЗУБЧАТЫЕ ДЛЯ ЗАЖИМА ВАЛОВ

**CALOWA WIELKOŚĆ KĄTA ZĄBKÓW 1/16" x 90° ODER 3/32" x 90°**

ДЮЙМОВОЕ ЗУБЧАТОЕ СОЕДИНЕНИЕ 1/16" x 90° ИЛИ 3/32" x 90°



Nr produktu	Typ szczęk	N	B	H	T	b	Śruby	kg / kpl.	
							Винты	кг / кпл.	
398522654200	SWKB-B C160-12-04	12	32	40	28	2 x 15	M 8	1,0	
398522656800	SWKB-B C160-17-01	17	35	40	28	19	M 12	1,1	
398522655500	SWKB-B C160-14-01	14	30	40	28	20	M 10	1,0	
1/16" x 90°	398522657000	SWKB-B C200-17-01	17	35	45	34	22	M 12	1,6
	398522658300	SWKB-B C250-17-01	17	35	45	34	22	M 12	1,8
	398522659600	SWKB-B C250-21-02	21	45	50	40	28	M 16	2,8
	398522660300	SWKB-B C315-21-01	21	45	50	40	28	M 16	3,3
	3/32" x 90°	398522661600	SWKB-B C400-25,5-01	25,5	60	55	46	35	M 20



Wkładki teowe

Т-образные вкладки

str.

492-501

стр.



Materiał szczęk  
Материал кулачков



Wielkość kąta ząbków  
Зубчатое соединение

Dystrybucja: unihurt.pl



Zamówienia: info@unihurt.pl



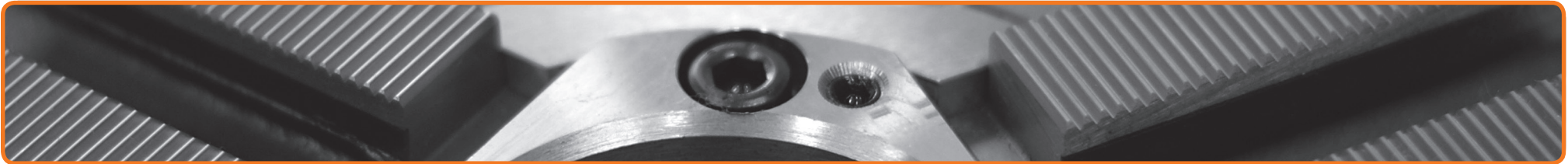

	SCHUNK			FORKARDT			RÖHM			SMW-AUTOBLOK			BERG		
	Zakres mocowania	Max. wysięg szczęk	Typ uchwytu	Zakres mocowania	Max. wysięg szczęk	Typ uchwytu	Zakres mocowania	Max. wysięg szczęk	Typ uchwytu	Zakres mocowania	Max. wysięg szczęk	Typ uchwytu	Zakres mocowania	Max. wysięg szczęk	Typ uchwytu
	Диапазон зажима	Макс. вылет кулачков	Тип патрона	Диапазон зажима	Макс. вылет кулачков	Тип патрона	Диапазон зажима	Макс. вылет кулачков	Тип патрона	Диапазон зажима	Макс. вылет кулачков	Тип патрона	Диапазон зажима	Макс. вылет кулачков	Тип патрона
1/16" x 90°	28 - 44	185	HSG 160				14 - 29	170	KFD-HS 160						
	15 - 40	172	ROTA NCD 160/165				14 - 43	184	KFD-HS 175						
	16 - 37	176	ROTA NC/TH 165; ROTA NCF/THF 165	14 - 32	171	KTN 160	14 - 32	171	KFD 160	15 - 30	170	HFH/HFKS 160; KDV/KDVG 160	15 - 30	170	HES 160; HESF 160; KF 160
	14 - 54	232	ROTA NCD 185	12 - 32	171	NH/NHF 160	14 - 32	171	KFD-HF 160	15 - 30	170	KFMF/KFV 160			
				11 - 46	185	QLC/QLK 175	15 - 32	171	KFH 160						
	14 - 34	176	TP 160							14 - 35	176	AL-D 165			
	15 - 43	185	ROTA NCK plus 165							14 - 29	170	AN-D/BH-D 165			
										14 - 41	182	BB-D 175			
										15 - 30	171	GHD-FC/GHDN 165			
	19 - 48	210	HSG 200	14 - 43	205	KTN 200	14 - 43	205	KFD 200	20 - 45	206	HFH/HFKS 200; KDV/KDVG 200 KFMF/KFV 200; GHD-FC/GHDN 210	20 - 45	206	HES 200; HESF 200; KF 200; KHFF 200
	15 - 66	228	ROTA NCK plus 215	14 - 43	205	NH/NHF 200	14 - 43	205	KFD-HF 200	20 - 45	206				
	15 - 54	217	ROTA NC/TH 210; ROTA NCF/THF 210	14 - 53	216	QLC/QLK 200	14 - 43	205	KFD-HS 200	22 - 57	219	AL-D 210			
	14 - 54	224	ROTA NCD 210				16 - 43	205	KFH 200	14 - 49	212	AN-D/BH-D 210			
	17 - 59	222	TP 200							18 - 51	213	BB-D 210			
	35 - 88	276	HSG 250	20 - 55	241	NHF 250 (Index)	17 - 83	270	KFD-HS 250						
21 - 83	270	ROTA NCK plus 250				18 - 83	270	KFL 250							
18 - 62	263	ROTA NC/TH 250; ROTA NCF/THF 250	17 - 59	260	KTN 250	17 - 59	260	KFD 250	20 - 55	255	HFH/HFKS 250; KDV/KDVG 250 KFMF/KFV 250; GHD-FC/GHDN 210	20 - 55	255	HES 250; HESF 250; KF 250; KHFF 250	
19 - 74	275	ROTA NCD 250	17 - 53	254	NH/NHF 250	15 - 59	260	KFD-HF 250	20 - 55	255	GHD-FC/GHDN 250				
24 - 80	281	TP 250	17 - 66	267	QLC/QLK 250	16 - 59	260	KFH 250	20 - 58	259	AN-D/BH-D 250				
									28 - 69	269	AL-D 250				
									27 - 60	259	BB-D 250				
									24 - 58	259	BHD-FC 250				
25 - 100	341	HSG 315	20 - 91	332	KTN 315	20 - 91	332	KFD 315	40 - 80	320	HFH/HFKS 315; KDV/KDVG 315 KFMF/KFV 315; GHD-FC/GHDN 315	40 - 80	320	HES 315; HESF 315; KF 315; KHFF 315	
21 - 96	337	ROTA NCK plus 315	20 - 92	333	NH/NHF 315	20 - 92	333	KFD-HF 315	40 - 80	320					
25 - 90	331	ROTA NC/TH 315; ROTA NCF/THF 315	20 - 97	338	QLC/QLK 315	20 - 97	338	KFD-HS 315	27 - 87	327	AN-D/BH-D 315				
25 - 98	339	ROTA NCD 315				25 - 92	333	KFH 315	27 - 99	339	AL-D 315				
25 - 107	348	TP 315				25 - 92	333	KFL 315	45 - 91	331	BB-D 315				
									22 - 87	327	BHD-FC 315				
									57 - 94	328	BHD-FC 400				
3/32" x 90°	30 - 106	444	HSG 400	30 - 99	436	KTN 400	30 - 99	436	KFD 400	50 - 100	438	HFH/HFKS 400	50 - 100	438	HES 400; KF 400; KHFF 400
	32 - 101	438	HSL 400	30 - 101	438	NH/NHF 400	30 - 101	438	KFD-HF 400	44 - 112	448	AL-D 400			
	30 - 101	438	ROTA NC/TH 400; ROTA NCF/THF 400	30 - 99	436	QLC/QLK 400	30 - 99	436	KFD-HS 400	44 - 100	436	AN-D 400			
	33 - 101	438	ROTA NCD 400						40 - 100	438	KFH 400				
	48 - 165	504	HSG 500	30 - 198	597	KTN 500	40 - 150	500	KFD 500	60 - 120	458	HFH/HFKS 500	60 - 120	458	HES 500; KF 500
	69 - 160	500	ROTA NC/TH 500; ROTA NCF/THF 500	136 - 198	537	NH/NHF 500	40 - 150	500	KFD-HF 500				60 - 120	458	HES 630; KF 630
	48 - 160	500	ROTA NCD 500				40 - 150	500	KFD-HS 500						
						40 - 150	500	KFH/KFL 500							





- 1
- 2
- 3
- 4
- 5
- 6
- 7
- C

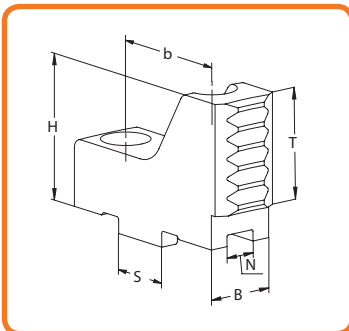

**SZCZĘKI CHWYTAKOWE DO MOCOWANIA WAŁKÓW**  
 КУЛАЧКИ ЗУБЧАТЫЕ ДЛЯ ЗАЖИМА ВАЛОВ

**Z WPUSTEM I ROWKIEM**  
 С СИСТЕМОЙ ПАЗ-ШПОНКА

Nr produktu	Typ szczęk	N	S	B	H	T	b	kg / kpl.	Pozycja szczęk podstawowych
								кг / кпл.	Положение мастер кулачков
398522662900	SWKB-B Z160-18-61	8	18	22	40	28,4	32	0,7	II
398522663100	SWKB-B Z200-20-01	10	20	22	45	34,4	40	0,8	II
398522664400	SWKB-B Z250-20-51	12	20	26	45	34,4	40	1,0	II
398522664400	SWKB-B Z250-20-51	12	20	26	45	34,4	40	1,0	II
398522665700	SWKB-B Z315-26-11	12	26	32	50	40	54	2,2	II
398522665700	SWKB-B Z315-26-11	12	26	32	50	40	54	2,2	II
398522664400	SWKB-B Z250-20-51	12	20	26	45	34,4	40	1,0	II
398522664400	SWKB-B Z250-20-51	12	20	26	45	34,4	40	1,0	II
398522665700	SWKB-B Z315-26-11	12	26	32	50	40	54	2,2	II
398522664400	SWKB-B Z250-20-51	12	20	26	45	34,4	40	1,0	II
398522665700	SWKB-B Z315-26-11	12	26	32	50	40	54	2,2	II

Ø 160 - 315 mm

Pozycja szczęk podstawowych  
 Положение мастер кулачков

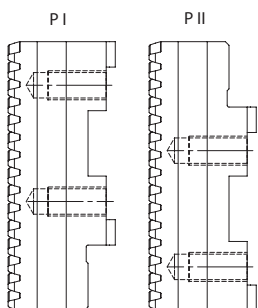

Oś BISON  
 Ось BISON

Dystrybucja: [unihurt.pl](http://unihurt.pl)



Zamówienia: [info@unihurt.pl](mailto:info@unihurt.pl)

SWKB-B Z

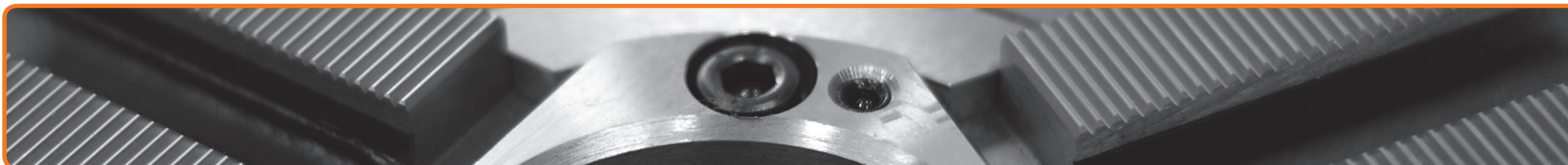

Ø 160 - 315 mm	SCHUNK			FORKARDT			RÖHM			SMW-AUTOBLOK			BERG		
	Zakres mocowania	Max. wysięg szczęk	Typ uchwytu	Zakres mocowania	Max. wysięg szczęk	Typ uchwytu	Zakres mocowania	Max. wysięg szczęk	Typ uchwytu	Zakres mocowania	Max. wysięg szczęk	Typ uchwytu	Zakres mocowania	Max. wysięg szczęk	Typ uchwytu
	Диапазон зажима	Макс. вылет кулачков	Тип патрона	Диапазон зажима	Макс. вылет кулачков	Тип патрона	Диапазон зажима	Макс. вылет кулачков	Тип патрона	Диапазон зажима	Макс. вылет кулачков	Тип патрона	Диапазон зажима	Макс. вылет кулачков	Тип патрона
	10 - 46	198	ROTA-G 160				10 - 43	209	DURO 160	12 - 28	193	HG-F 160	10 - 47	214	KHNC 160
	10 - 42	208	ROTA-S plus 160				10 - 42	208	DURO-NC 160	17 - 43	191	HG-N 160	26 - 62	229	KHNC 185
	10 - 30	177	THW 165-R				10 - 48	214	DURO-NCE 160	13 - 38	186	KNCS 175			
	15 - 39	190	ROTA THW plus 165				10 - 66	239	DURO-NC 175	17 - 44	192	KNCS-N 170			
	17 - 62	212	ROTA THW plus 185												
	24 - 62	248	ROTA-G 200	22 - 52	234	F 200	11 - 87	275	DURO 200	13 - 59	247	HG-F 210	17 - 35	223	KHNC 200
	14 - 52	248	ROTA-S plus 200	11 - 75	263	F+ 200	10 - 103	291	DURO-NC 200	17 - 62	240	HG-N 210			
	18 - 52	241	THW 210-R	17 - 54	241	KTNC 200	13 - 58	246	DURO-NCE 200	18 - 58	236	KNCS 200			
	11 - 83	264	ROTA THW plus 215	18 - 75	263	KTNCV 200	10 - 93	281	DURO-NCES 200 F	16 - 89	267	KNCS-N 210			
				19 - 75	263	FNC 200	15 - 89	267	DURO-NCES 200 R	16 - 81	259	KNCS-N 225			
	15 - 82	312	ROTA-G 250	20 - 60	300	F 250	13 - 86	326	DURO 250	22 - 55	295	HG-F 260	14 - 46	286	KHNC 250
	13 - 62	310	ROTA-S plus 250	13 - 80	320	F+ 250	13 - 108	348	DURO-NC 250	16 - 67	295	HG-N 260			
	13 - 65	297	THW 250-R	13 - 67	307	KTNC 250	13 - 68	308	DURO-NCE 250	15 - 65	293	KNCS 250			
	19 - 82	315	ROTA THW plus 260	13 - 90	326	KTNCV 250	13 - 108	348	DURO-NCES 250 F	13 - 86	314	KNCS-N 260			
				13 - 90	330	FNC 250	13 - 86	314	DURO-NCES 250 R						
	21 - 102	359	ROTA-G 315										24 - 93	334	KHNC 315
	14 - 92	389	ROTA-S plus 315	24 - 75	358	F 315	14 - 102	384	DURO 315	18 - 86	382	HG-F 315			
				14 - 102	384	F+ 315	14 - 137	419	DURO-NC 315						
	14 - 86	335	THW 315-R	13 - 91	331	KTNC 315	28 - 122	362	DURO-NCE 315	17 - 100	351	HG-N 315			
	14 - 121	373	ROTA THW plus 315	13 - 126	366	KTNCV 315				22 - 85	335	KNCS 315			
				13 - 125	366	FNC 315				23 - 102	346	KNCS-N 315			
							14 - 123	405	DURO-NCES 315 F						
							13 - 114	364	DURO-NCES 315 R						
	34 - 122	412	ROTA-G 400	15 - 138	420	KTNC 400	85 - 167	449	DURO-NCE 400	24 - 128	400	HG-N 400	24 - 92	375	KHNC 400
	23 - 120	410	THW 400-R	37 - 192	475	KTNCV 400	35 - 166	449	DURO-NCES 400 R	21 - 106	388	KNCS 400			
				15 - 166	448	FNC 400				35 - 122	405	KNCS-N 400			

- 1
- 2
- 3
- 4
- 5
- 6

7

Dystrybucja: [unihurt.pl](http://unihurt.pl)



Zamówienia: [info@unihurt.pl](mailto:info@unihurt.pl) BKMS



- 1
- 2
- 3
- 4
- 5
- 6
- 7
- C

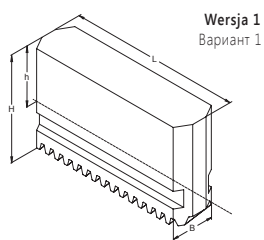

Wersja 1  
Вариант 1

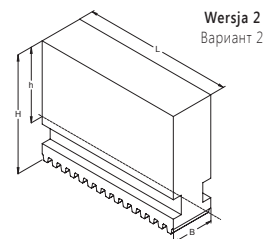

Wersja 2  
Вариант 2

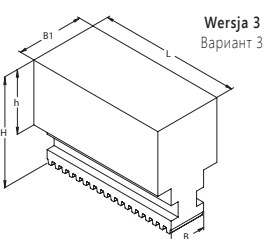

Wersja 3  
Вариант 3

**SZCZĘKI JEDNOLITE MIĘKKIE**  
 КУЛАЧКИ МЯГКИЕ ЦЕЛЬНЫЕ

**SYSTEM REISHAUER LUB FORKARDT**  
 СИСТЕМА REISHAUER ИЛИ FORKARDT

Nr produktu Код продукта	Typ szczęk Тип кулачков	Wersja Вариант	B	B <sub>1</sub>	H	h	L	kg / kpl.	Typ ząbienia
								кг / кпл.	Тип зубчатой
398531151900	SJM 160 RHU	2	20	-	55	35	65	1,6	R
398531155000	SJM 160 F	1	20	-	45	24	79	1,5	F
398531156200	SJMH 160 F	1	20	-	60	39	79	2,0	F
398531161000	SJM 200 RHU	2	22	-	65	40	84	2,6	R
398531163600	SJMH 200 RHU	2	22	-	85	60	84	3,5	R
398531162300	SJMB 200 RHU	3	22	40	65	38	84	3,9	R
398531165100	SJM 200 F	1	22	-	60	35	94	2,6	F
398531166400	SJMH 200 F	1	22	-	80	55	94	3,5	F
398531141700	SJM 250 RHU	2	26	-	84	55	99	4,7	R
398531143200	SJMH 250 RHU	2	26	-	115	86	99	6,6	R
398531142000	SJMB 250 RHU	3	26	46	84	53	99	7,2	R
398531145800	SJM 250 F	1	26	-	70	40	115	4,4	F
398531146000	SJMH 250 F	1	26	-	100	70	115	6,4	F
398531171200	SJM 315 RHU	2	32	-	90	56	121	7,5	R
398531173800	SJMH 315 RHU	2	32	-	135	101	121	11,5	R
398531172500	SJMB 315 RHU	3	32	46	90	54	121	9,6	R
398531175300	SJM 315 F	1	32	-	81	46	130	6,8	F
398531176600	SJMH 315 F	1	32	-	135	100	130	12,0	F
398531185500	SJM 400 F	1	45	-	93	53	176	15,2	F

Ø 160 - 400 mm

**Typ ząbienia**  
 Тип зубчатой

**System Reishauer [R]**  
 Система Reishauer [R]



**System Forkardt [F]**  
 Система Forkardt [F]



SJM F

SJM RHU

Dystrybucja: unihurt.pl



Zamówienia: info@unihurt.pl

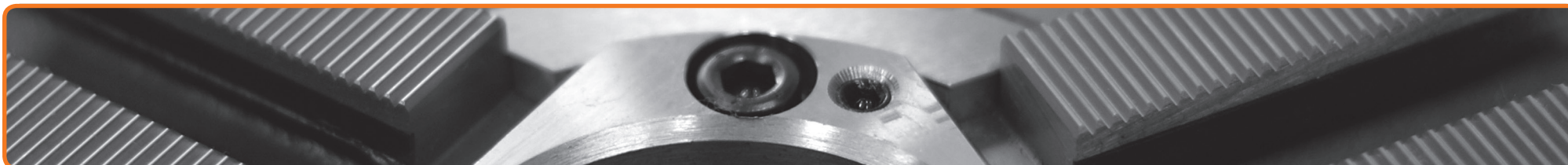

	SCHUNK	FORKARDT	RÖHM	SMW-AUTOBLOK
Ø 160 - 400 mm	ROTA-G 160; ROTA NCW 185; ROTA THW 165; ROTA THW plus 165-185; THW 165			HG 160; HG-N 160; KNCS 140-160-175; KNCS-N 140-170; KNPS 160; RMG 160
	ROTA-S 160; ROTA-S plus 160	F 160; F+ 160; FNC 175; KTNC 160; KTNCV 160-175	DURO 160; DURO-NC 160-175; DURO-NCE 160-175; DURO-NCES 175	HG-F 160
	ROTA-G 200; ROTA NCW 225; ROTA THW 210; ROTA THW plus 215; THW 210-R; ROTA THW vario 215			HG 200; HG-N 210; KNCS 200-210; KNCS-N 210-225; KNPS 200; RMG 200
	ROTA NCWF 210; ROTA-S 200; ROTA-S plus 200; THW 210-F	F 200; F+ 200; FNC 200; KTNC 200; KTNCV 200	DURO 200; DURO-NC 200-225; DURO-NCE 200; DURO-NCES 200	HG-F 210
	ROTA-G 250; ROTA NCW 265; ROTA THW 250; ROTA THW plus 260; THW 250-265-R			HG 250; HG-N 260; KNCS 250-260; KNCS-N 260-275; RMG 250
	ROTA NCWF 250-315; ROTA-S 250; ROTA-S plus 250; THW 250-265-F	F 250; F+ 250; FNC 250-315; KTNC/KTNCV 250-315; UNC 250-315	DURO 250; DURO-NC 250; DURO-NCE 250-315; DURO-NCES 250	HG-F 260
	ROTA-G 315; ROTA NCW 315; ROTA THW 315; ROTA THW plus 315; THW 315-R			HG 315; HG-N 315; KNCS 315; KNCS-N 315-340
	ROTA-S 315; ROTA-S plus 315; THW 315-400-F	F 315; F+ 315; FNC 400; KTNC 360-400; KTNCV 400; UNC 400	DURO 315; DURO-NC 315; DURO-NCE 400; DURO-NCES 315	HG-F 315
ROTA-S 400; ROTA-S plus 400	F 400; F+ 400	DURO 400; DURO-NC 400; DURO-NCES 400	HG-F 400	

1

2

3

4

5

6

7

Dystrybucja: unihurt.pl



Zamówienia: info@unihurt.pl | MRS



- 1
- 2
- 3
- 4
- 5
- 6
- 7
- C

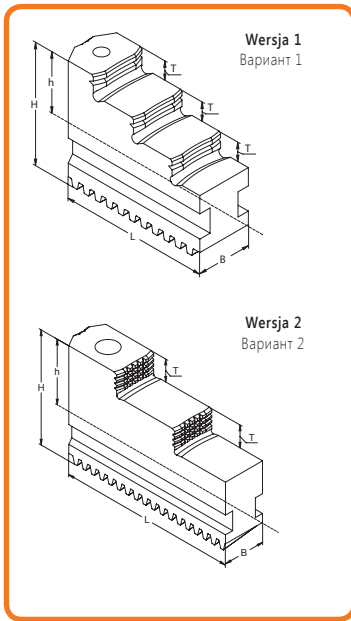

**SZCZĘKI JEDNOLITE TWARDE**  
 КУЛАЧКИ ЦЕЛЬНЫЕ КАЛЕННЫЕ

**SYSTEM REISHAUER LUB FORKARDT**  
 СИСТЕМА REISHAUER ИЛИ FORKARDT

Nr produktu Код продукта	Typ szczęk Тип кулачков	Wersja Вариант	B	H	L	T	h	kg / kpl.	Typ zażębienia
								кг / кпл.	Тип зубчатой
398530923800	SJT 160 RHU-03	1	20	46,0	66,6	7	24	0,9	R
398530921200	SJT 160 RHU-01	1	20	44,0	58,0	7	22	0,8	R
398530922500	SJT 160 RHU-02	1	20	44,0	58,0	7	22	0,8	R
398530925300	SJT 160 F	1	20	45,0	79,0	7,5	24	1,1	F
398530933000	SJT 200 RHU-01	1	22	54,0	84,8	8	29	1,6	R
398530935500	SJT 200 F	1	22	60,0	94,0	10	35	1,9	F
398530941600	SJT 250 RHU-01	1	26	65,0	107,4	10	36	2,9	R
398530945700	SJT 250 F	2	26	70,0	115,0	14	40	3,3	F
398530951800	SJT 315 RHU-01	1	32	66,0	117,0	11	32	3,5	R
398530955900	SJT 315 F	2	32	81,0	129,0	15	46	5,4	F
398530965000	SJT 400 F	2	45	93,3	167,2	20	53	10,8	F

Ø 160 - 400 mm

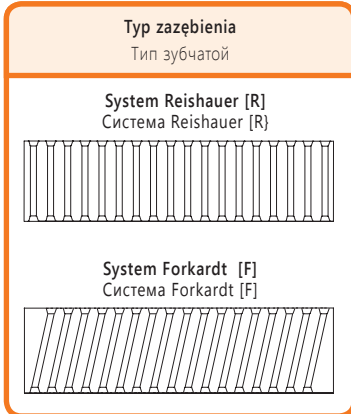

SJT F

SJT RHU

Dystrybucja: [unihurt.pl](mailto:unihurt.pl)  
 Zamówienia: [info@unihurt.pl](mailto:info@unihurt.pl)

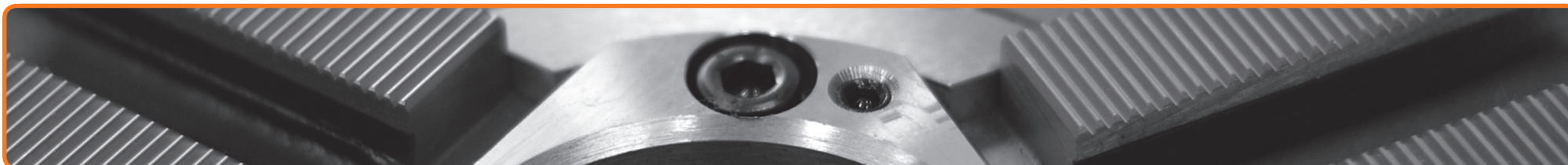

	SCHUNK	FORKARDT	RÖHM	SMW-AUTOBLOK
Ø 160 - 400 mm	ROTA-G 160; ROTA THW plus 185			KNCS 175; KNCS-N 170
	ROTA NCW 185; ROTA THW 165; ROTA THW plus 165; THW 165			HG 160; HG-N 160; KNCS 140-160; KNCS-N 140; KNCP 160; RMG 160
	ROTA-S 160; ROTA-S plus 160	F 160; F+ 160; FNC 175; KTNC 160; KTNCV 160-175	DURO 160; DURO-NC 160-175; DURO-NCE 160-175; DURO-NCES 175	HG-F 160
	ROTA-G 200; ROTA NCW 225; ROTA THW 210; ROTA THW plus 215; THW 210-R; ROTA THW vario 215			HG 200; HG-N 210; KNCS 200-210; KNCS-N 210-225; KNCP 200; RMG 200
	ROTA NCWF 210; ROTA-S 200; ROTA-S plus 200; THW 210-F	F 200; F+ 200; FNC 200; KTNC 200; KTNCV 200	DURO 200; DURO-NC 200-225; DURO-NCE 200; DURO-NCES 200	HG-F 210
	ROTA-G 250; ROTA NCW 265; ROTA THW 250; ROTA THW plus 260; THW 250-265-R			HG 250; HG-N 260; KNCS 250-260; KNCS-N 260-275
	ROTA NCWF 250-315; ROTA-S 250; ROTA-S plus 250; THW 250-265-F	F 250; F+ 250; FNC 250-315; KTNC/KTNCV 250-315; UNC 250-315	DURO 250; DURO-NC 250; DURO-NCE 250-315; DURO-NCES 250	HG-F 260
	ROTA-G 315; ROTA NCW 315; ROTA THW 315; ROTA THW plus 315; THW 315-R			HG 315; HG-N 315; KNCS 315; KNCS-N 315-340
	ROTA-S 315; ROTA-S plus 315; THW 315-400-F	F 315; F+ 315; FNC 400; KTNC 360-400; KTNCV 400; UNC 400	DURO 315; DURO-NC 315; DURO-NCE 400; DURO-NCES 315	HG-F 315
ROTA-S 400-500; ROTA-S plus 400-500; THW 500-F	F 400-500 L; F+ 400-500 L; FNC 500-630; KTNC/KTNCV 500-630; UNC 500	DURO 400-500; DURO-NC 400-500; DURO-NCE 500; DURO-NCES 400	HG-F 400-500	

1  
2  
3  
4  
5  
6  
7

Dystrybucja: [unihurt.pl](http://unihurt.pl)

Zamówienia: [info@unihurt.pl](mailto:info@unihurt.pl)

F TJS



1  
2  
3  
4  
5  
6  
7  
C

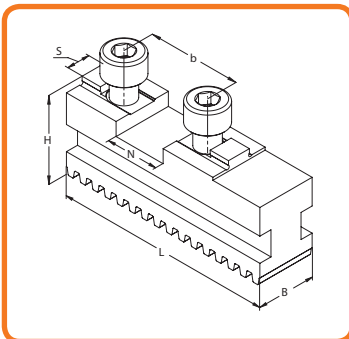

- Wersja 1: Standardowe
- Wersja 2: Krótkie
- Wersja 3: Długie
- Вариант 1: Стандартные
- Вариант 2: Короткий
- Вариант 3: Длинные

**SZCZĘKI PODSTAWOWE**  
 КУЛАЧКИ МАСТЕР (РЕЙКИ)

**SYSTEM REISHAUER LUB FORKARDT**  
 СИСТЕМА REISHAUER ИЛИ FORKARDT

Nr produktu	Typ szczęk	Wersja	N	S	B	H	L	b	kg / kpl.	Typ zażebienia
									кг / кпл.	Тип зубчатой
398530975200	SP 140 RHU-01	1	18	8	20	30	56	32	0,6	R
398530982600	SP 160 RHU-02	1	18	8	20	29,5	74	32	0,7	R
398530980000	SP 160 RHU	1	18	8	20	30	65	32	0,7	R
398530985400	SP 160 F	1	18	8	20	29,5	74	32	0,7	F
398530986700	SP-S 160 F	2	18	8	20	29,5	64	32	0,6	F
398530992800	SP 200 RHU-02	1	20	10	22	35	90	40	1,2	R
398530990200	SP 200 RHU	1	20	10	22	32	85	40	1,0	R
398530993000	SP-L 200 RHU	3	20	10	22	32	105	40	1,3	R
398530995600	SP 200 F	1	20	10	22	35	90	40	1,2	F
398530996900	SP-S 200 F	2	20	10	22	35	80	40	1,0	F
398530997100	SP-L 200 F	3	20	10	22	35	110	40	1,4	F
398531002100	SP 250 RHU-02	1	20	12	26	40	110	40	2,2	R
398531001900	SP 250 RHU-01	1	20	12	26	40	104	40	1,8	R
398531003400	SP-L 250 RHU	3	20	12	26	40	126	40	2,2	R
398531005000	SP 250 F	1	20	12	26	40	110	40	1,8	F
398531006200	SP-S 250 F	2	20	12	26	40	91	40	1,5	F
398531007500	SP-L 250 F	3	20	12	26	40	122	40	2,1	F
398531011000	SP 315 RHU-01-20	1	20	12	32	46	115	40	3,1	R
398531013600	SP-L 315 RHU-20	3	20	12	32	46	137	40	3,7	R
398531015100	SP 315 F	1	26	12	32	46	125	54	3,0	F
398531017700	SP-L 315 F	3	26	12	32	46	160	54	3,9	F
398531025300	SP 400 F	1	30	18	45	55	160	60	6,6	F
398531027900	SP-L 400 F	3	30	18	45	55	200	60	8,6	F

Ø 140 - 400 mm

**Typ zażebienia**  
 Тип зубчатой

**System Reishauer [R]**  
 Система Reishauer [R]

**System Forkardt [F]**  
 Система Forkardt [F]

**Śruby**  
 Винты

str. 504  
 стр.

Dystrybucja: unihurt.pl  
 Zamówienia: info@unihurt.pl



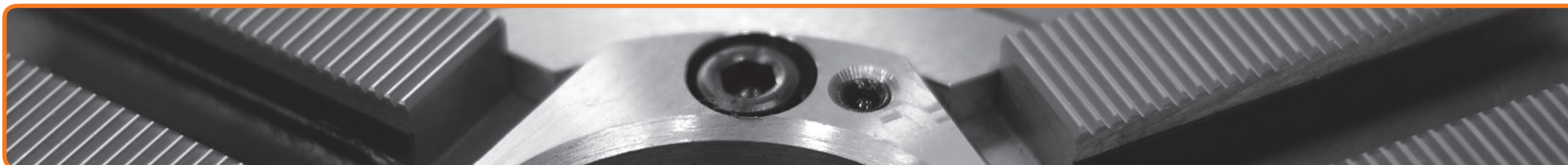

	SCHUNK	FORKARDT	RÖHM	SMW-AUTOBLOK	BERG
Ø 140 - 400 mm				KNCS 140; KNCS-N 140	KHNC 160; KHNC 185
	ROTA-G 160; ROTA NCW 185; ROTA THW 165; ROTA THW plus 165-185; THW 165			HG 160; HG-N 160; KNCS 160-175; KNCS-N 170; KNSP 160; RMG 160	
	ROTA-S 160; ROTA-S plus 160	F 160; F+ 160; FNC 175; KTNC 160; KTNCV 160-175	DURO 160; DURO-NC 160-175; DURO-NCE 160-175; DURO-NCES 175	HG-F 160	KHNC 200
	ROTA-G 200; ROTA NCW 225; ROTA THW 210; ROTA THW plus 215; THW 210-R; ROTA THW vario 215			HG 200; HG-N 210; KNCS 200-210; KNCS-N 210-225; KNSP 200; RMG 200	
	ROTA NCWF 210; ROTA-S 200; ROTA-S plus 200; THW 210-F	F 200; F+ 200; FNC 200; KTNC 200; KTNCV 200	DURO 200; DURO-NC 200-225; DURO-NCE 200; DURO-NCES 200	HG-F 210	KHNC 250; KHNC 315
	ROTA-G 250; ROTA NCW 265; ROTA THW 250; ROTA THW plus 260; THW 250-265-R			HG 250; HG-N 260; KNCS 250-260; KNCS-N 260-275; RMG 250	
	ROTA NCWF 250-315; ROTA-S 250; ROTA-S plus 250; THW 250-265-F	F 250; F+ 250; FNC 250-315; KTNC/KTNCV 250-315; UNC 250-315	DURO 250; DURO-NC 250; DURO-NCE 250-315; DURO-NCES 250	HG-F 260	
	ROTA-G 315; ROTA NCW 315; ROTA THW 315; ROTA THW plus 315; THW 315-R			HG 315; HG-N 315; KNCS 315; KNCS-N 315-340	
	ROTA-S 315; ROTA-S plus 315; THW 315-400-F	F 315; F+ 315; FNC 400; KTNC 360-400; KTNCV 400; UNC 400	DURO 315; DURO-NC 315; DURO-NCE 400; DURO-NCES 315	HG-F 315	
	ROTA-S 400-500; ROTA-S plus 400-500; THW 500-F	F 400-500 L; F+ 400-500 L; FNC 500-630; KTNC/KTNCV 500-630; UNC 500	DURO 400-500; DURO-NC 400-500; DURO-NCE 500; DURO-NCES 400	HG-F 400-500	

1

2

3

4

5

6

7

Dystrybucja: unihurt.pl



Zamówienia: info@unihurt.pl  
SP R

1  
2  
3  
4  
5  
6  
7  
D

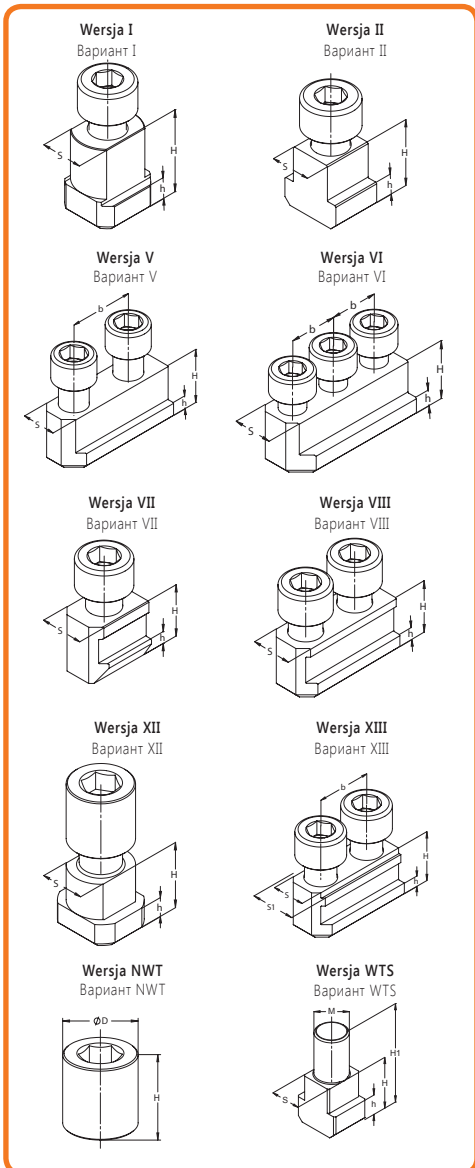

WKŁADKI TEOWE  
T-ОБРАЗНЫЕ ВКЛАДКИ

KONFIGURACJA POJEDYŃCZA LUB PODWÓJNA  
ОДИНАРНАЯ ИЛИ ДВОЙНАЯ КОНФИГУРАЦИЯ

Nr produktu	Typ wkładki teowej	Wersja	S/S <sub>166</sub>	H	h	b	Śruby		Nm*
							Винты		
398522833800	WTF05-8xM6-01	V	8	13,5	4,5	15	M 6 x 18	16	
398522165200	WTS 9	WTS	8	17,3	7	-	M 9 x 1	45	
398522160900	NWT 9	NWT	-	13	-	-	M 9 x 1	45	
398522869000	WTF06-10xM6-01	VI	10	13,7	5,5	2 x 12	M 6 x 18	16	
398522834000	WTF05-10xM8-01	V	10	15,0	5,0	14	M 8 x 20	30	
398522837900	WTF05-10xM8-04	V	10	15,5	5,5	18	M 8 x 22	30	
398522818800	WTF02-10xM8-01	II	10	15,5	6,5	-	M 8 x 20	30	
398522835300	WTF05-10xM8-02	V	10	15,7	6,5	15	M 8 x 20	30	
398522836600	WTF05-10xM8-03	V	10	16,0	5,0	14	M 8 x 20	30	
398522838100	WTF05-10xM8-05	V	10	18,0	5,5	14	M 8 x 22	30	
398522839400	WTF05-10xM8-06	V	10	18,0	5,5	19	M 8 x 22	30	
398522166500	WTS 10	WTS	10	20,3	9,3	-	M 10	60	
398522161100	NWT 10	NWT	-	16	-	-	M 10	60	
398522819000	WTF02-11xM8-01	II	11	15,5	6,5	-	M 8 x 20	30	
398522840100	WTF05-11xM8-01	V	11	17,5	6,5	16	M 8 x 22	30	
398522801700	WTF01-11xM8-02	I	11	19	7	-	M 8 x 20	30	
398522841400	WTF05-11xM8-02	V	11	20	7	20	M 8 x 25	30	
398522800400	WTF01-11xM8-01	I	11	21	7	-	M 8 x 30	30	
398522842700	WTF05-12xM8-01	V	12	15	6,5	16	M 8 x 22	30	
398522820800	WTF02-12xM8-01	II	12	15	6,5	-	M 8 x 20	30	
398522887800	WTF12-12xM10-01	XII	12	17	7	-	M 10	40	
398522802000	WTF01-12xM8-01	I	12	17,2	7	-	M 8 x 20	30	
398522870700	WTF06-12xM8-01	VI	12	17,2	7	2 x 15	M 8 x 22	30	
398522843000	WTF05-12xM10-01	V	12	18,5	7,5	20	M 10 x 25	50	
398522844200	WTF05-12xM10-02	V	12	22	7	20	M 10 x 25	50	
398522167800	WTS 12	WTS	12	23,2	9	-	M 12	100	
398522162400	NWT 12	NWT	-	19	-	-	M 12	100	
398522822300	WTF02-14xM10-02	II	14	16,5	6,5	-	M 10 x 20	50	
398522871000	WTF07-14xM10-01	VII	14	18,5	6,5	-	M 10 x 25	50	
398522875000	WTF08-14xM10-01	VIII	14	18,5	6,5	20	M 10 x 25	50	
398522890000	WTF13-12/14xM10-01	XIII	12/14	18,5	6,5	20	M 10 x 25	50	
398522888000	WTF12-14xM12-01	XII	14	18,5	8	-	M 12	62	
398522821000	WTF02-14xM10-01	II	14	20	7,5	-	M 10 x 25	50	

\* Max. dopuszczalny moment dokręcania \* Макс. допустимый момент затяжки

Dystrybucja: unihurt.pl



Zamówienia: info@unihurt.pl

WT

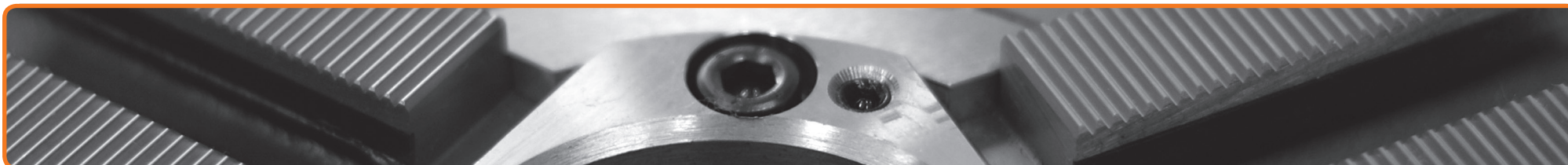

	SCHUNK	KITAGAWA	FORKARDT	HOWA	MMK / MATSUMOTO	RÖHM	SMW-AUTOBLOK	BERG	
Ø 100 - 165 mm		B 04; HOB 04						KH 110	
	HSG 140; ROTA NCD 130					KFD 110-125; KFD 140; KFD-HS 125-130-140			
		B 204; B 205 B 05; HOB 05					KFD-HE 130; KFN 105 KFD-HS 110		
		AS 110; HJ 4; N 04 HJ 5; N 05		HO 1 MA 4; HO 24 M 5	ZA 5-5				
								KH 140; KH 160	
							KFM 130; KFN 130-135; KFE 170; KFG 160; KFM 160; KFN 160		
				HO 27 M 4; HO 27 M 5					
						ZA 5-6-421		HFKS 130	
	ROTA TP 125; TP 125							SP 125 bis Bj. 98; STP 125; STWP 125 GHDN 125; ODN 125	
								BH-D/BH-M 130; PB-D/PB-M 130; PBI-D/PBI-M 130; HB-D/HB-M 130; BB-D 140; BB-M 130	
			KTHS 130-140						
	HSG 160; ROTA NCD 160-165						KFD 130; KFD-HS 160; KFN 140; LVE 125 KFD-HE 170; KFD-HS 160-175	KDV 130	KF 130
	ROTA NCK 165; ROTA NCK plus 165; ROTA NCD 160-165; ROTA NC/NCF plus 185	B 06; BB 06; B 106; B 206; BB 206; B 7; B 07; HOH 06; HOH 106; HOH 206				YA 5-6-46; ZA 5-6-46	KFD-HE 170		
	HSL 165; ROTA NC/NCF 165	AS 165; B 160; HJA 5-6; HO 6; HOB 6; HOH 160; HOS 6; N 06; N 160		HO 1 MA 6; HO 7 MA 6; HO 15 M 6; HO 22 M 6; HO 24 M 6; HO 27 M 6; HO 37 M 6; HO 47 M 6					
									KH 175; KH 200
							KFE 215; KFG 215; KFM 215; KFN 215		
	ROTA NCK plus 165; ROTA NCR 250-315; ROTA NCF 185; ROTA NC/NCF plus 185							AL-D/AN-D 165; BB-D 175; BH-D/BHD-FC 165; HB-D 165; HFKN-D 165; HYDN-S 180; PB-D/PBI-D 165	
								AL-M 165; AN-M 165; BH-M 165; BHM-FC 165; HB-M 165; PB-M 165; BB-M 175	
		KTHS 160-175							
							GHD-FC 165; GHDN 165; HDB/HDL/HDN 170; ODL/ODN 170		

- 1
- 2
- 3
- 4
- 5
- 6
- 7

Dystrybucja: unihurt.pl

Zamówienia: info@unihurt.pl LM

1  
2  
3  
4  
5  
6  
7  
D

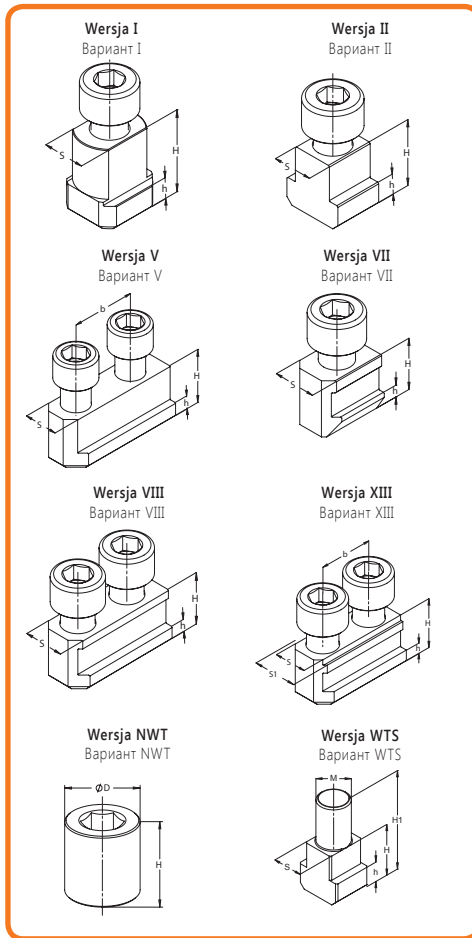

**WKŁADKI TEOWE**  
T-ОБРАЗНЫЕ ВКЛАДКИ

**KONFIGURACJA POJEDYŃCZA LUB PODWÓJNA**  
ОДИНАРНАЯ ИЛИ ДВОЙНАЯ КОНФИГУРАЦИЯ

Nr produktu Код продукта	BISON Typ BISON Type	Wersja Вариант	S/S <sub>165</sub>	H	h	b	Śruby Винты		Nm*
398522891300	WTF13-14/17xM12-01	XIII	14/17	20,5	7,5	25	M 12 x 30	70	
398522845500	WTF05-14xM12-01	V	14	20,5	8,5	25	M 12 x 30	70	
398522846800	WTF05-14xM12-02	V	14	22	8,5	25	M 12 x 30	70	
398522847000	WTF05-14xM12-03	V	14	24,5	8,5	25	M 12 x 35	70	
398522803200	WTF01-14xM10-01	I	14	25,5	8,5	-	M 10 x 35	50	
398522848300	WTF05-16xM12-01	V	16	21,5	8,5	30	M 12 x 30	70	
398522849600	WTF05-16xM12-02	V	16	23,0	8,0	30	M 12 x 30	70	
398522850300	WTF05-16xM12-03	V	16	24,5	8,5	30	M 12 x 35	70	
398522851600	WTF05-16xM12-04	V	16	26,5	8,5	25	M 12 x 35	70	
398522892600	WTF13-16/17xM12-01	XIII	16/17	26,5	10	30	M 12 x 35	70	
398522168000	WTS 16	WTS	16	26,7	12	-	M 16	250	
398522163700	NWT 16	NWT	-	25	-	-	M 16	250	
398522872200	WTF07-17xM12-01	VII	17	20,5	7,5	-	M 12 x 25	70	
398522876300	WTF08-17xM12-01	VIII	17	20,5	7,5	22	M 12 x 25	70	
398522805800	WTF01-17xM12-02	I	17	22,0	9	-	M 12 x 30	70	
398522806000	WTF01-17xM12-03	I	17	22,0	9	-	M 12 x 25	70	
398522852900	WTF05-17xM12-01	V	17	21,5	9	19	M 12 X 25	70	
398522806000	WTF01-17xM12-03	I	17	22	9	-	M 12 X 25	70	
398522823600	WTF02-17xM12-01	II	17	22,3	8,3	-	M 12 x 30	70	

Ø 165 - 200 mm

\* Max. dopuszczalny moment dokręcania \* Макс. допустимый момент затяжки

Dystrybucja: unihurt.pl  
Zamówienia: info@unihurt.pl

WT

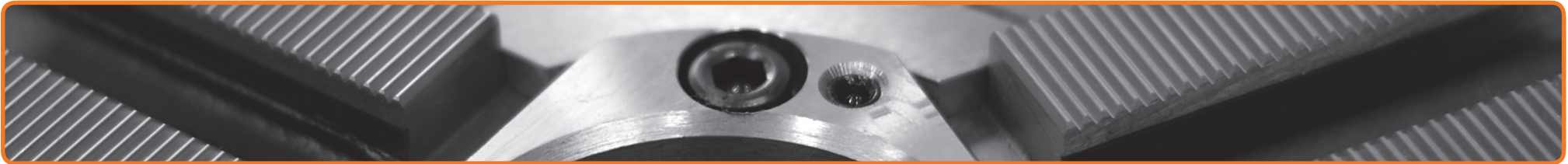

	SCHUNK	KITAGAWA	HOWA	MMK / MATSUMOTO	RÖHM	SMW-AUTOBLOK	BERG
Ø 165 - 200 mm	ROTA NCK 210; ROTA NCK plus 210; ROTA NCD 210; ROTA NC/NCF plus 215	B 108; B 208; BB 208; BB 08; HOH 108; HOH 208		ZA 6-8-52; ZA 6-8-66	KFD-HE 210	AL-M 210; AN-M 210; BB-M 210; BH-M 210; BHM-FC 210; HB-M 210; PB-M 210	
	HSL 210; ROTA NC/NCF 210	AS 210; B 08; B 200; HJA 6-8 HO 8; HOB 8; HOH 8; HOH 200; HOS 8; N 08; N 200	HO 1 MA 8; HO 2 M 8; HO 7 MA 8; HO 15 M 8; HO 23 M 8				
	ROTA TP 160; TP 160						
	ROTA NCK 250; ROTA NCK plus 250; ROTA NCD 250; ROTA NC/NCF plus 260	B 110; B 210; BB 210; BB 10; HOH 110; HOH 210			KFD-HE 254		
			HO 1 MA 10; HO 2 M 10	ZA 8-10-66; HA 8-10-66; ZA 6-10-75			
	HSL 250; ROTA NC/NCF 250	AS 250; B 10; B 250; HJA 6-10; HJA 8-10; HO 10; HOB 10; HOH 10; HOH 250; HOS 10; N 10; N 250					
			HO 22 M 8; HO 24 M 8; HO 27 M 8; HO 37 M 8; HO 47 M 8; HO 7 MA 10; HO 15 M 10; HO 23 M 10				
						AL-M 250; AN-M 250; BB-M 250; BH-M 250; BHM-FC 250; HB-M 250; PB-M 250	
							KH 250; KH 315
	ROTA 2B 160; ROTA NC 165-210; ROTA NCD 185; ROTA NCF 165-210; ROTA NCO 165-210; ROTA NCK plus 210-250; ROTA NC/NCF plus 21						AL-D/AN-D 210; BB-D 210; BH-D/BHD-FC 210; HB-D 210; HFKN-D 210; PB-D/PBI-D 210
						HES 160; HESF 160; KF 160; HES 200; HESF 200; KF 200, KHFF 200	
					KFD 160; KFD-AF 160; KFD-HF 160; KFH 160; KFH-F 160; KFH-G 160; KFH-NC 160; LVE 160; SPD 160; SPO 160	BH-D/BH-M 130; PB-D/PB-M 130; PBI-D/PBI-M 130; HB-D/HB-M 130; BB-D 140; BB-M 130	
HSG 200-250					KFD-HS 200		
						CD 200; GHD/FC 210; GHDN 210; HDB/HDL/HDN 200-220; ODL/ODN 200-220	

- 1
- 2
- 3
- 4
- 5
- 6
- 7

Dystrybucja: unihurt.pl  
  
 Zamówienia: info@unihurt.pl LM

- 1
- 2
- 3
- 4
- 5
- 6
- 7
- D

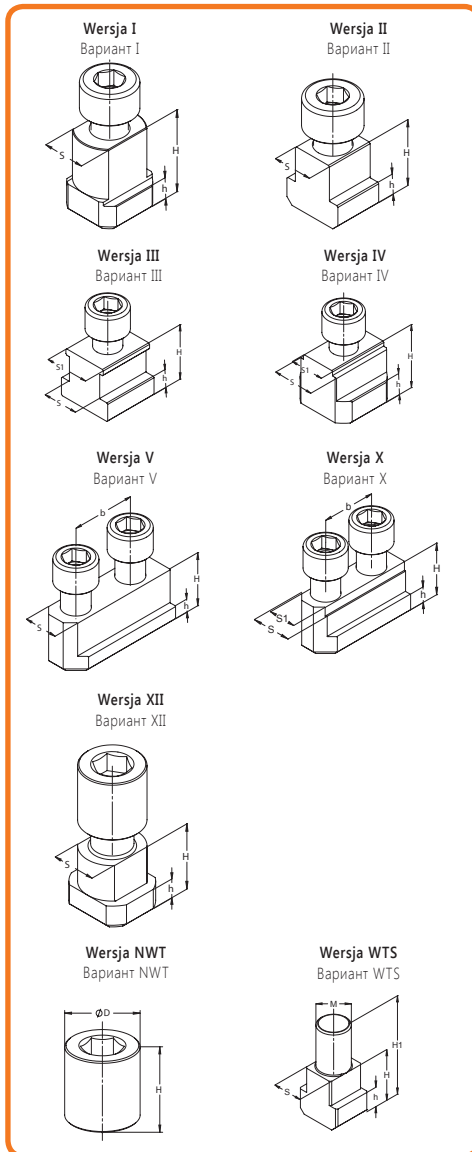

**WKŁADKI TEOWE**  
T-ОБРАЗНЫЕ ВКЛАДКИ

**KONFIGURACJA POJEDYŃCZA LUB PODWÓJNA**  
ОДИНАРНАЯ ИЛИ ДВОЙНАЯ КОНФИГУРАЦИЯ

Nr produktu Код продукта	BISON Typ BISON Type	Wersja Вариант	S/S <sub>166</sub>	H	h	b	Śruby	Nm*
							Винты	
398522804500	WTF01-17xM12-01	I	17	23	9	-	M 12 x 30	70
398522853100	WTF05-17xM12-02	V	17	23	9	19	M 12 x 30	70
398522854400	WTF05-17xM12-03	V	17	23	9	22	M 12 x 30	70
398522829200	WTF03-17/21xM12-01	III	17/21	24	9	-	M 12 x 30	70
398522889300	WTF12-17xM14-01	XII	17	23	9	-	M 14	90
398522807300	WTF01-17xM12-04	I	17	27	9	-	M 12 x 35	70
398522855700	WTF05-18xM14-01	V	18	25,5	9,5	30	M 14 x 40	130
398522856000	WTF05-18xM14-02	V	18	27,5	9,5	30	M 14 x 40	130
398522857200	WTF05-18xM14-03	V	18	33,5	13,5	30	M 14 x 45	130
398522824900	WTF02-20xM12-01	II	20	21,5	8,5	-	M 12 x 30	70
398522169300	WTS 20	WTS	20	32,7	16	-	M 20	300
398522164000	NWT 20	NWT	-	32	-	-	M 20	300
398522825100	WTF02-21xM16-01	II	21	23	8,5	-	M 16 x 35	150
398522859800	WTF05-21xM16-02	V	21	23	8,5	-	M 16 x 30	150
398522810600	WTF01-21xM16-03	I	21	25,5	11	-	M 16 x 35	150
398522858500	WTF05-21xM16-01	V	21	23	11,5	30	M 15 x 35	150
398522879100	WTF10-21/17xM12-01	X	21/17	25,5	11	19	M 12 x 30	70
398522830000	WTF04-21/17xM12-01	IV	21/17	25,5	11	-	M 12 x 30	70
398522808600	WTF01-21xM16-01	I	21	27	11	-	M 16 x 35	150
398522860500	WTF05-21xM16-03	V	21	27	11	28	M 16 x 35	150
398522831200	WTF04-21/17xM12-02	IV	21/17	27	11	-	M 12 x 30	70

Ø 160 - 250 mm

\* Max. dopuszczalny moment dokręcania \* Макс. допустимый момент затяжки

Dystrybucja: unihurt.pl  
Zamówienia: info@unihurt.pl

WT



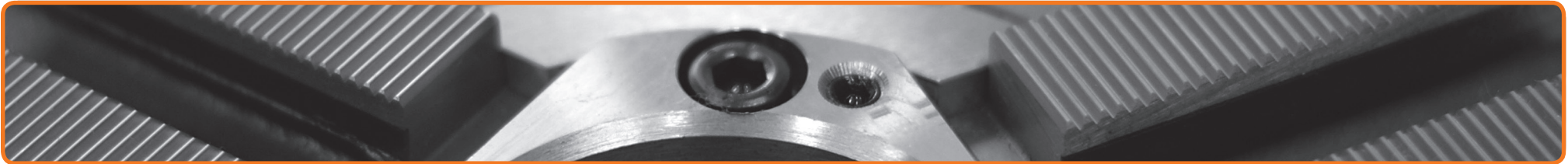

	SCHUNK	KITAGAWA	FORKARDT	HOWA	MMK / MATSUMOTO	RÖHM	SMW-AUTOBLOK
Ø 160 - 250 mm	HSL 165-210; ROTA NCD 210; ROTA NC/NCF plus 165; TH/THF 165-210		KG 200; KGH/KGHF 160-175-200; KL/KLNC/KP 160-200; KS/KSHF 160-200-250; KSF 175-200; KSH/KSPS 160-200; KT/KTG/KTN 160-200; KTH 160-175-200; KTGF 200; NH/NHF 160-175-200; QLC/QLK 160-175-200; QLC-KS/QLK-KS 200-250; KL/KS 250 (Monforts); NHF 250-290 (Index); UVE 160-200-250				KZF/KZF-ES 200; HFK/HFKS 250-315; KDV 315-400; KDVG 315-400; KFMF 250-315; KFV 250-315
	ROTA TP 200; TP 200		KTHS 200-250-315				SP/STP/STWP 200; LP 205
					ZA 8-12-78		
	HSL 315			HO 22 M 10; HO 24 M 10; HO 27 M 10; HO 37 M 10; HO 47 M 10; HO 7 MA 12; HO 15 M 12; HO 23 M 12			
	ROTA NC/NCF 315	B 12; B 300; HJA 6-12; HJA 8-12; HLA 6-12; HLA 6-15; HLA 8-15; HO 12; HOB 12; HOH 12; HOH 300; HOS 12; N 12; N 300		HO 1 MA 12; HO 2 M 12			
						KFE 280; KFG 280; KFM 280; KFN 250-280	
							KH 400; KH 500; KH 630
						KFE 350; KFG 350; KFM 350; KFN 350	
						KFA 200; KFD 250-315; KFD-AF 250-315; KFD-HE 254-315; KFD-HF 250-315; KFH 250-315; KFH-F 250-315; KFH-G 250-315; KFH-NC 250-315; KFL 315-400; LVE 250-305-315; SPD 300; SPO 300; KFD-HS 315	BHD-FC/BHM-FC 400; CD 250-315; 2 CLD 200; US-2 CLD 200; GHD/GHM 400; GHD-FC/GHDN 250-305-315-400; HDB 300; HDL/HDN 250-315-400; ODL/ODN 250-315-400; RCD 400
		BB 212					
						KFD-HS 250	HDN 250 S; ODN 250 S
	HSL 250-315; ROTA NC 315; ROTA NCD 250-315; ROTA NCF 315; TH/THF 250-315		2BLE 200-250 (Monforts); 2BLN 200; KG 250-315; KL 250; KLNC/KP 250-315; KS 315-400; KSH/KSHF 250-400; KSPS 250-300; KT/KTG/KTGF/KTN 250-315; NH/NHF 250-315; NHF 257-290; NHF 400 (Index); QLC/QLK 250-315; QLC-KS/QLK-KS 315-400; UVE 315				

- 1
- 2
- 3
- 4
- 5
- 6
- 7

Dystrybucja: unihurt.pl

Zamówienia: info@unihurt.pl LM



- 1
- 2
- 3
- 4
- 5
- 6
- 7
- D

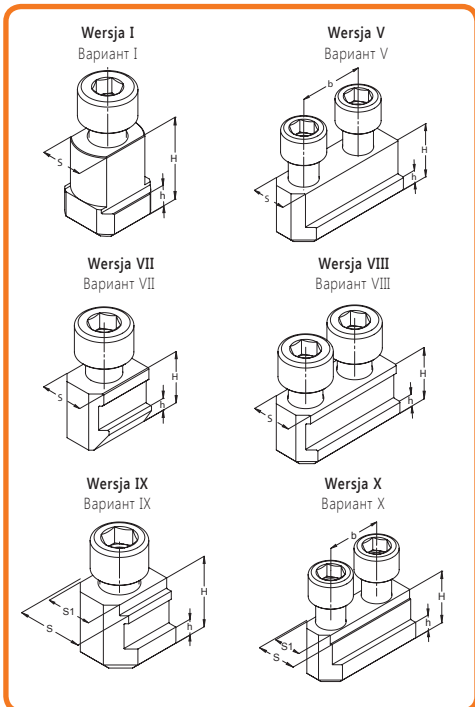

**WKŁADKI TEOWE**  
T-ОБРАЗНЫЕ ВКЛАДКИ

**KONFIGURACJA POJEDYŃCZA LUB PODWÓJNA**  
ОДИНАРНАЯ ИЛИ ДВОЙНАЯ КОНФИГУРАЦИЯ

Nr produktu Код продукта	BISON Typ BISON Type	Wersja Вариант	S/S <sub>166</sub>	H	h	b	Śruby Винты		Nm*
398522873500	WTF07-21xM16-01	VII	21	26,5	10	-	M 16 x 35	150	
398522877600	WTF08-21xM16-01	VIII	21	26,5	10	28	M 16 x 35	150	
398522878900	WTF09-21/17xM12-01	IX	21/17	26,5	10	-	M 12 x 30	70	
398522809900	WTF01-21xM16-02	I	21	27	10	-	M 16 x 35	150	
398522808600	WTF01-21xM16-01		21	27	11	-	M 16 x 35	150	
398522861800	WTF05-21xM16-04	V	21	28	11,5	30	M 16 x 40	150	
398522862000	WTF05-21xM16-05	V	21	29,0	10,5	35	M 16 x 40	150	
398522811900	WTF01-21xM16-04	I	21	30	11	-	M 16 x 35	150	
398522863300	WTF05-22xM20-01	V	22	39,5	19,5	50	M 20 x 50	300	
398522864600	WTF05-22xM20-02	V	22	45,5	16,5	60	M 20 x 55	300	
398522882400	WTF10-24/22xM20-02	IX	24/22	45,5	16,5	43	M 20 x 60	300	
398522880900	WTF10-24/21xM16-01	X	24/21	45,5	16,5	30	M 16 x 60	150	
398522881100	WTF10-24/22xM20-01	X	24/22	40,5	16,5	43	M 20 x 55	300	
398522865900	WTF05-25xM20-01	V	25	45,0	19,0	60	M 20 x 60	300	
398522883700	WTF10-25/22xM20-01	X	25/22	45,0	19,0	50	M 20 x 60	300	
398522866100	WTF05-25xM20-02	V	25	54,0	19,0	60	M 20 x 70	300	

\* Max. dopuszczalny moment dokręcania \* Макс. допустимый момент затяжки

Dystrybucja: unihurt.pl  
Zamówienia: info@unihurt.pl

WT

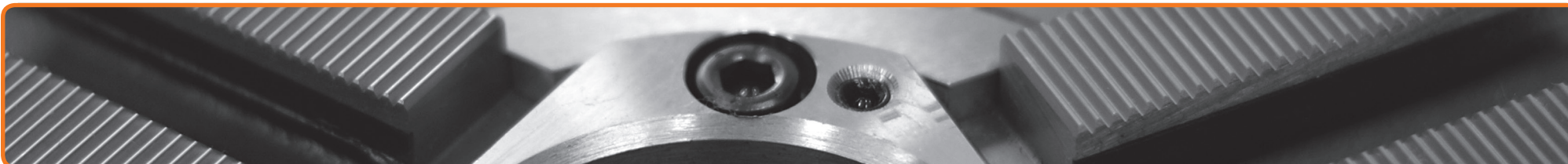

	SCHUNK	KITAGAWA	HOWA	MMK / MATSUMOTO	RÖHM	SMW-AUTOBLOK	BERG
Ø 250 - 400 mm	ROTA NC 250; ROTA NCF 250; ROTA NCO 260-315; ROTA 2B 200; ROTA NC plus 260-315; ROTA NCK plus 315; ROTA NCF plus 260-315; ROTA NCR 400-500					AL-D/AN-D 250-315; BB-D 250-315; AP-D 315; BH-D 250-315; BH-D FC 250-315; HB-D 250-315; HFKN-D 260-315; HYDN-S 250-315; PB-D/PBI-D 250-315; RCD 250-305	
							HES 250; HESF 250; KF 250; KHFF 250; HES 315; HESF 315; KF 315; KHFF 315
	HSG 315; ROTA NCR 630-800	B 112; B 212; HOH 112; HOH 212				KFD-HE 315	
			HO 27 M 12; HO 37 M 12; HO 47 M 12				
	ROTA TP 250-315-350; TP 250-315; ROTA EP 500						LP 250-305; SP/STP/STWP 250-280-315-350
		HLA 8-18; HLA 8-21		ZA 11-15-120; HA 15-18-16; ZA 8-15-120			
		HJ 15; HJ 380					
	ROTA NC/NCF 400; HSL 400	B 15; B 380; B 18; B 450; HOB 15; HOB 18; HOH 15					
		HOH 15-K					
		B 21; B 24; HOB 21; HOB 24; N 21; N 24					
	HJ 18; HJ 21; HJ 24						

- 1
- 2
- 3
- 4
- 5
- 6
- 7

Dystrybucja: [unihurt.pl](http://unihurt.pl)  
Zamówienia: [info@unihurt.pl](mailto:info@unihurt.pl) LM

- 1
- 2
- 3
- 4
- 5
- 6
- 7

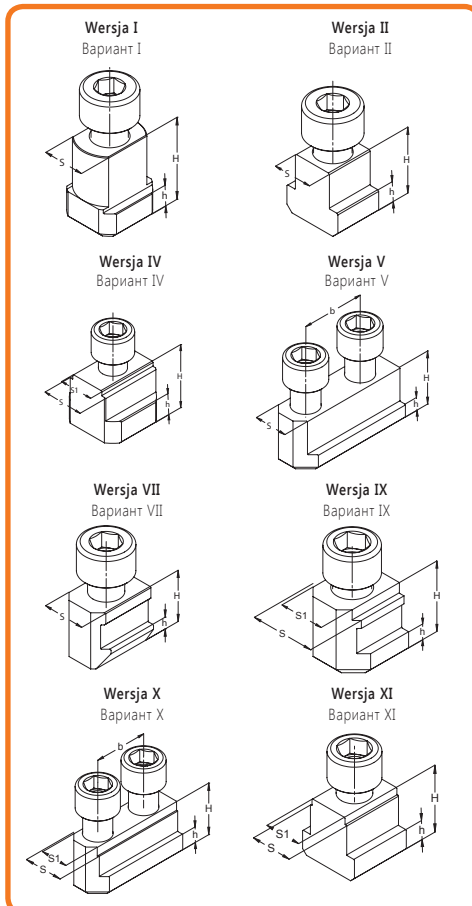

**WKŁADKI TEOWE**  
T-ОБРАЗНЫЕ ВКЛАДКИ

**KONFIGURACJA POJEDYŃCZA LUB PODWÓJNA**  
ОДИНАРНАЯ ИЛИ ДВОЙНАЯ КОНФИГУРАЦИЯ

Nr produktu Код продукта	BISON Typ BISON Type	Wersja Вариант	S/S <sub>166</sub>	H	h	b	Śruby Винты		Nm*
398522812100	WTF01-25,5xM20-01	I	25,5	29	11	-	M 20 x 40	220	
398522867400	WTF05-25,5xM20-01	V	25,5/21	29	11	35	M 20 x 40	220	
398522832500	WTF04-25,5/21xM16-01	IV	25,5	29	11	-	M 16 x 35	150	
398522867400	WTF05-25,5xM20-01	V	25,5	29	11	-	M 20 x 40	220	
398522867400	WTF05-25,5xM20-01	V	25,5	29	11	35	M 20 x 40	220	
398522813400	WTF01-25,5xM20-02	I	25,5	33,7	15,5	-	M 20 x 45	300	
398522874800	WTF07-25,5xM20-01	VII	25,5	34	15	-	M 20 x 45	220	
398522826400	WTF02-25,5xM18-01	II	25,5	34,5	14,5	-	M 18 x 55	220	
398522828000	WTF02-25,5xM20-01	II	25,5	34,5	14,5	-	M 20 x 55	220-240	
398522814700	WTF01-25,5xM20-03	I	25,5	36	16	-	M 20 x 50	300	
398522884000	WTF10-25,5/22xM20-01	X	25,5/22	39,5	19,0	43	M 20 x 55	300	
398522827700	WTF02-25,5xM18-02	II	25,5	67	14,5	-	M 18 x 90	220	
398522885200	WTF11-28/25,5xM20-01	XI	28/25,5	40	15,5	-	M 20 x 40	300	
398522868700	WTF05-26xM20-01	V	26	40,0	17,0	50	M 20 x 50	300	
398522886500	WTF11-30/25,5xM20-01	XI	30/25,5	41	15	-	M 20 x 50	220	
398522817500	WTF01-30xM24-03	I	30	41	15	-	M 24 x 60	450	
398522816200	WTF01-30xM24-02	I	30	41	15	-	M 24 x 70	450	
398522815000	WTF01-30xM24-01	I	30	41	15	-	M 24 x 50	450	

Ø 400 - 1000 mm

\* Max. dopuszczalny moment dokręcania \* Макс. допустимый момент затяжки

Dystrybucja: unihurt.pl  
Zamówienia: info@unihurt.pl

WT

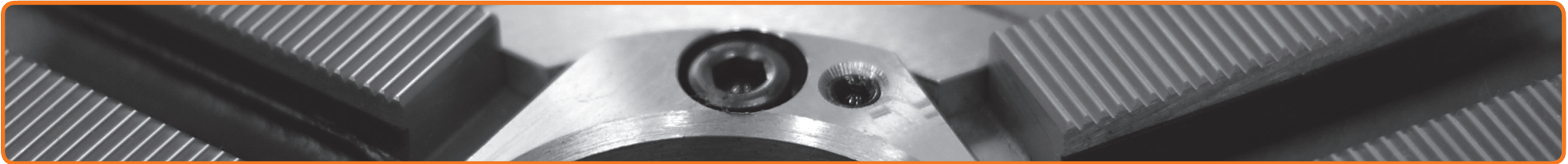

	SCHUNK	KITAGAWA	FORKARDT	HOWA	RÖHM	SMW-AUTOBLOK	BERG	
Ø 400 - 1000 mm	HSL 400; ROTA NC 400-500; ROTA NCD 400-500; ROTA NCF 400-500; TH/THF 400-500		2BLE 250-315; 2BLN 250-315; KG 400-500; KL/KLNC 400-500; KP 400-500; KS 500; KSH 500; KSPS 400; KT/KTGF 400-500; KTG/KTN 400-500; NH/NHF 400-500; QLC/QLK 400; UVE 400-500			HFK 400-500; HFKN-D 400-500; HFKS 400-500; KfV 400-500; KDV 500; KDVG 500		
	ROTA 2B 250-315-400; ROTA NCO 800; ROTA NCR 1000					KDS 630; KfV 630-800		
	HSG 400-500; ROTA NCO 400-500				KFA 250-315; KFD 400-500-630-800; KFD-HE 400; KFD-HF 400-500-630; KFD-HS 400-500; KFH 400-500; KFH-F 400-500; KFH-G 400-500; KFH-NC 400-500; KFL 500-600; LVE 400-500-630-800	2 CLD 250-315; US 2 CLD 250-315	KHFF 400	
	ROTA EP 380-460; ROTA EP-LH 460; ROTA TB 400-500-610; ROTA TB-LH 400-500-610; TB 400-500					AL-D/AL-M 400; AN-D/AN-M 400; BB-N 400-460-500; BB-N ES 400-460-500; BH-D 400-450; BH-D FC 500-630; BH-D 630-800	BB 400-500; BB 400 ES; LP 380-460-500; STP 400-500	
								HES 400; HESF 400; KF 400; HES 500; HESF 500; KF 500; HES 630; HESF 630; KF 630
	ROTA TB-LH 630-265; TB 630-265 LH	B 215; N15					BB 500 ES; BB 630 ES 265	
							GHD 610-640-800; ILD 500-630-800; IND 500-630-800	
	ROTA NC 630-800 ROTA NC 630-800				HO 1 MA 15; HO 1 M 18; HO 1 MA 21; HO 1 MA 24			
	ROTA TB-LH 630-325; ROTA TB 630-800-1000; ROTA TB-LH 850-1000-1200; TB 630; TB 630-325 LH; TH 630						BB 630-800-1000; BB 630-325 ES; BB 850-1000 ES; BB-N 630-800-1000; BB-N ES 630-800-1000; STP 630-800	
	ROTA NCO 1000; ROTA NC 1000					KFD 1000-1250	KDS 800-1000-1200; KVV 1000	

- 1
- 2
- 3
- 4
- 5
- 6
- 7

Dystrybucja: [unihurt.pl](http://unihurt.pl)

Zamówienia: [info@unihurt.pl](mailto:info@unihurt.pl) LM



WKŁADKI TEOWE  
T-ОБРАЗНЫЕ ВКЛАДКИ

KONFIGURACJA POJEDYŃCZA LUB PODWÓJNA  
ОДИНАРНАЯ ИЛИ ДВОЙНАЯ КОНФИГУРАЦИЯ

Wersja I  
Вариант I

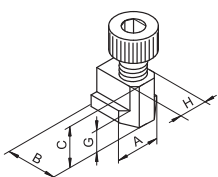

Wersja II  
Вариант II

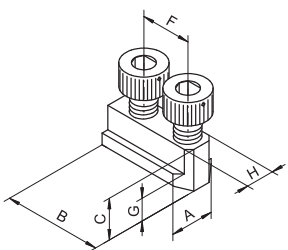

Nr produktu Код продукта	Wersja Вариант	A	B	C	F	G	H h6	Śruby	kg	Uchwyt BISON
								Винты	кг	Патрон BISON
398522147400	II	15,0	26,0	15,0	14	5,5	10,0	M8x16	0,02	2104-135K, 2105-135-34K 2405-135K, 2405-135-34K 2605-135K, 2605-135-34K
398522108000	II	17,5	36,0	18,5	20	7,5	12,0	M10x20	0,04	2105-160K, 2105-160-45K 2405-160K, 2405-160-45K 2605-160K, 2605-160-45K
398522151000	II	17,5	34	16,0	18	7,5	12	M10x20	0,04	2409-160-46
398522110000	II	23	42	21,5	24	9,5	17,0	M12x25	0,10	2104-160, 2105-160-45 2404-160, 2405-160-45 2604-160, 2605-160-45 2409-200-66
398522111200	II	20,5	46,5	20,5	25	8,5	14,0	M12x25	0,09	2104-200K, 2105-200-52K 2404-200K, 2405-200-52K 2604-200K, 2605-200-52K
398522120100	I	23	19	21,5	-	9,0	17,0	M12x25	0,03	2104-200, 2105-200-52 2404-200, 2405-200-52 2604-200, 2605-200-52 2409-250-91 2409-315-91 2488-200
398522131600	II	22,5	51,0	21,5	30	8,5	16,0	M12x30	0,12	2104-250, 2105-250-75K 2404-250, 2405-250-75K 2604-250, 2605-250-75K
398522130300	I	27	24	25,5	-	10,5	21,0	M16x30	0,05	2104-250, 2105-250-75 2404-250, 2405-250-75 2604-250, 2605-250-75 2488-315
398522132900	II	29,0	55,5	27,0	30	10,5	21,0	M16x30	0,21	2104-315K, 2105-315-91K 2404-315K, 2405-315-91K 2605-315K, 2605-315-91K
398522130300	I	27	24	25,5	-	10,5	21,0	M16x30	0,05	2104-315, 2105-315-91 2404-315, 2405-315-91 2604-315, 2605-315-91
398522133100	II	34,0	80,0	31,0	43	12,0	25,5	M20x40	0,38	2404-400K, 2405-400-120K
398522140500	I	34	30	29,0	-	12,0	25,5	M20x40	0,09	2404-400, 2405-400-120
398522134400	I	34	30	29,0	-	12,0	25,0	M20x40	0,09	2404-500K, 2405-500-160K 2404-630K, 2405-630-200K 2404-800K, 2405-800-255K
398522140500	I	34	30	29,0	-	12,0	25,5	M20x40	0,09	2404-500, 2405-500-160 2404-630, 2405-630-200 2404-800, 2405-800-255

Ø 135 - 800 mm

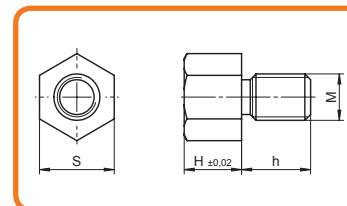

**KOŁKI OPOROWE**  
 ОПОРНЫЕ ШПИЛЬКИ

**DO SZCZĘK CHWYTAKOWYCH**  
 ДЛЯ ЗУБЧАТЫХ КУЛАЧКОВ

Nr produktu	Typ	H	S	h	kg / kpl.
Код продукта	Type				кг / кпл.
<b>M 5</b>					
398521355400	KB KB-M5x5	5	8	8	0,010
398521356700	KB KB-M5x10	10	8	8	0,016
398521357000	KB KB-M5x15	15	8	8	0,023
<b>M 6</b>					
398521360200	KB KB-M6x5	5	10	10	0,016
398521361500	KB KB-M6x10	10	10	10	0,026
398521362800	KB KB-M6x15	15	10	10	0,037
398521363000	KB KB-M6x20	20	10	10	0,047
398521364300	KB KB-M6x25	25	10	10	0,057
<b>M 8</b>					
398521365600	KB KB-M8x5	5	13	10	0,027
398521366900	KB KB-M8x10	10	13	10	0,047
398521367100	KB KB-M8x15	15	13	10	0,064
398521368400	KB KB-M8x20	20	13	10	0,081
398521369700	KB KB-M8x25	25	13	10	0,098
398521370400	KB KB-M8x30	30	13	10	0,113

■ Możliwość regulacji głębokości mocowania przedmiotu obrabianego „T”, za pomocą wymiennych kołków oporowych.

■ Śruby nie wchodzą w zakres dostawy i muszą być zamawiane oddzielnie.

■ Возможность регулировки глубины крепления обрабатываемой детали «Т» при помощи съемных опорных шпилек.

■ Эти шпильки не входят в комплект поставки и должны быть заказаны отдельно.

- 1
- 2
- 3
- 4
- 5
- 6
- 7

 Dystrybucja: [unihurt.pl](http://unihurt.pl)

 Zamówienia: [info@unihurt.pl](mailto:info@unihurt.pl)

**ŚRUBY MOCUJĄCE**  
ЗАЖИМНЫЕ ВИНТЫ

**DO SZCZĘK PODSTAWOWYCH • SP F • SP RHU**  
ДЛЯ МАСТЕР КУЛАЧКОВ • SP F • SP RHU

Nr produktu	Typ	Wymiar d x l	Szczęka podstawowa BISON
Код продукта	Тип	Размер d x L	Мастер кулачок BISON
398530901900	DIN 912 M8X1X20-10.9	M 8 x 1 x 20	SP 160 F; SP 200 F
398530902100	DIN 912 M12X1.5X30-10.9	M 12 x 1,5 x 30	SP 250 F
398530903400	DIN 912 M12X1.5X35-10.9	M 12 x 1,5 x 35	SP 315 F
398530904700	DIN 912 M16X1.5X40-10.9	M 16 x 1,5 x 40	SP 400 F
398530905000	EN ISO 4762 M8X20-12.9	M 8 x 20	SP 140 RHU; SP 160 RHU; SP 200 RHU
398530906200	EN ISO 4762 M12X25-12.9	M 12 x 25	SP 250 RHU
398530907500	EN ISO 4762 M12X30-12.9	M 12 x 30	SP 315 RHU

**ŚRUBY MOCUJĄCE**  
ЗАЖИМНЫЕ ВИНТЫ

**DO SZCZĘK GÓRNYCH TWARDYCH • DO UCHWYTÓW 3-SZCZĘKOWYCH**  
ДЛЯ КАЛЕННЫХ НАКЛАДНЫХ КУЛАЧКОВ • ДЛЯ 3-КУЛАЧКОВОЙ ПАТРОНОВ

Wielkość uchwytu [mm]	Śruba 1*		Śruba 2*	
Размер патрона [мм]	Винт 1*		Винт 2*	
125	M8x20	100001484	M8x25	100001474
160	M10x20	100003252	M10x30	100003241
200	M10x20	100003252	M10x30	100003241
250	M12x25	100003301	M12x40	100001592
315	M12x25	100003301	M12x40	100001592
400	M16x30	100001587	M16x45	100003319
500	M20x40	100002416	M20x75	100003352
630	M20x40	100002416	M20x80	100003360
800	M20x40	100002416	M20x80	100003360

\* 3 śruby w komplecie • 3 винту в комплекте

