



Tri-Linear Series: BMT-2098C-A

User Manual

Colour Line Scan Analog Camera

Balaji MicroTechnologies Pvt. Ltd.
(A Unit of B.B. Group of Companies)

Corporate Headquarter: New Delhi, India

Sales/business Operation: D-2/20, Sector-10 | DLF Faridabad-121006 |
Haryana, **INDIA**

Tel # +91-129-4006203 | +91-129-6561300

Email (For Overseas Sales): sales.overseas@balaji-microtechnologies.com

Email (For India Sales): sales.india@balaji-microtechnologies.com

Website: <http://www.balaji-microtechnologies.com/>

Table of Contents

1. INTRODUCTION	5
1.1 TYPICAL SPECIFICATION	5
1.2 SAFETY MEASURE	5
1.2.1 <i>Supply voltage Limitation</i>	5
1.2.2 <i>Power Supply of camera</i>	5
1.2.3 <i>Warranty</i>	6
2. ELECTRICAL & INTERFACE	7
2.1 CONNECTORS	7
2.1.1 <i>Power & I/O Connector</i>	7
2.1.2 <i>Analog & Digital BNC connector</i>	8
2.1.3 <i>RS-232 connector</i>	9
2.1.4 <i>RS-232 communication format</i>	9
2.1.5 <i>Cables</i>	9
3. CAMERA FUNCTIONS AND CONTROL	10
3.1 SERIAL CAMERA CONFIGURATION	10
3.2 INTERNAL & EXTERNAL CLOCK	11
3.3 WORKING MODES OF CAMERA	12
3.3.1 <i>Internal sync mode</i>	12
3.3.2 <i>Integration time for internal sync mode</i>	13
3.3.3 <i>External sync mode</i>	13
3.4 OUTPUT CLOCK DELAY	14
3.5 CAMERA RESET & SAVE CONFIGURATION	17
3.6 GAIN & OFFSET ADJUST	17
4. MECHANICAL	19
5. ORDERING CODE	20

List of Tables

TABLE 1-CAMERA SPECIFICATIONS.....	5
TABLE 2-LIMITS FOR SUPPLY VOLTAGE.....	5
TABLE 3 CONNECTOR INFORMATION.....	7
TABLE 4 POWER & I/O CONNECTOR.....	8
TABLE 5-CAMERA COMMAND LIST	10
TABLE 6 CAMERA RETURN STRING.....	11

List of Figures

FIGURE 1 CONNECTORS OF THE CAMERA	7
FIGURE 2 POWER & I/O CONNECTOR	8
FIGURE 3 RS-232 PIN CONNECTION	9
FIGURE 4 DIGITAL OUTPUT SIGNAL OF THE CAMERA	11
FIGURE 5 INTERNAL SYNC MODE	12
FIGURE 6 EXTERNAL SYNC MODE	13
FIGURE 7 SYNC OUTPUT VS. ANALOG OUTPUT	14
FIGURE 8 CLKOUT DELAY VS. ANALOG OUTPUT (0T, 0.25T, 0.5T, 0.75T)	16
FIGURE 9 GAIN AND OFFSET POTENTIOMETERS	17
FIGURE 10 MECHANICAL DIMENSIONS OF CAMERA	19

1. Introduction

1.1 Typical Specification

Name	Specification
Resolution	2098 Tri-Linear CCD (KLI-2113)
Pixel size	14×14 (μm×μm) (8 lines spacing)
MAX. data rate	20 MHz×3
MAX. line rate	≈9.2 KHz
Lens mount	Nikon F-Mount
Spectral response	400nm ~ 700nm Typical
Analog data format	0V ~ 5V @ 75Ω coax axial connectors
Digital IO format	RS-644 LVDS / 5V TTL for BNC SYNC output
Sync modes	Free-run / External Sync / External Clock
Integration time	16 bit via Serial
Gain & Offset	through potentiometer on board
Power supply	12 VDC, 5%
Power dissipation	< 4W
Working temp.	-10°C to 50°C / 20% to 80%
Storage temp.	-40°C to 75°C / 10% to 90%
Dimensions	100mm(W)×100mm(H)×66.2mm(D) with lens mount
Weight	< 500 GM

Table 1-Camera Specifications



BMT-2098C-A
BalaJi MicroTechnologies

1.2 Safety Measure

1.2.1 Supply voltage Limitation

MIN.	TYP.	MAX.
11.4 V DC	12V DC	12.6 V DC

Table 2-Limits for Supply Voltage

1.2.2 Power Supply of camera

	<p>Warning!</p> <ul style="list-style-type: none"> • Check camera supply voltage before using the camera. • Cut-off camera's power supply before plug or un-plug and connectors. • Do not reverse the polarity of the input power! Reversing the polarity of the input power can severely damage the camera and leave it non-operational.
--	---



Information!

Without sufficient cooling, the camera can get hot enough during operation. Allow sufficient air circulation around the camera to prevent internal heat build-up in your system and to keep the camera housing temperature during operation below 50°C. Provide additional cooling such as fans or heat sinks if necessary.

1.2.3 Warranty

- ✓ Camera comes with 12 months warranty from the date of Invoice subject to following below terms.
- ✓ Do not remove any of the camera's labels. If labels are removed, user accepts that the warranty of the camera is void.
- ✓ Read this Manual first before using the camera
- ✓ Keep foreign matter outside of the camera
- ✓ Do not open the housing. Touching internal components may damage them. Be careful not to allow liquids, flammable, or metallic material inside the camera housing. If operated with any foreign matter inside, the camera may fail or cause a fire.
- ✓ **Electromagnetic fields:** Do not operate the camera in the vicinity of strong electromagnetic fields. Avoid electrostatic charging.
- ✓ **Transporting:** Only transport the camera in its original packaging. Do not discard the packaging.
- ✓ **Cleaning:** Avoid cleaning the surface of the CCD sensor if possible. If you must clean it, use a soft, lint free cloth dampened with a small quantity of high quality window cleaner. Do not use ethylated alcohol. Because electrostatic discharge can damage the CCD sensor, you must use a cloth that will not generate electrostatic charge during cleaning (cotton is a good choice).
- ✓ To clean the surface of the camera housing, use a soft, dry cloth. To remove severe stains, use a soft cloth dampened with a small quantity of neutral detergent, then wipe dry. Do not use volatile solvents such as benzene and thinners; they can damage the surface finish of the camera.

2. Electrical & Interface

2.1 Connectors

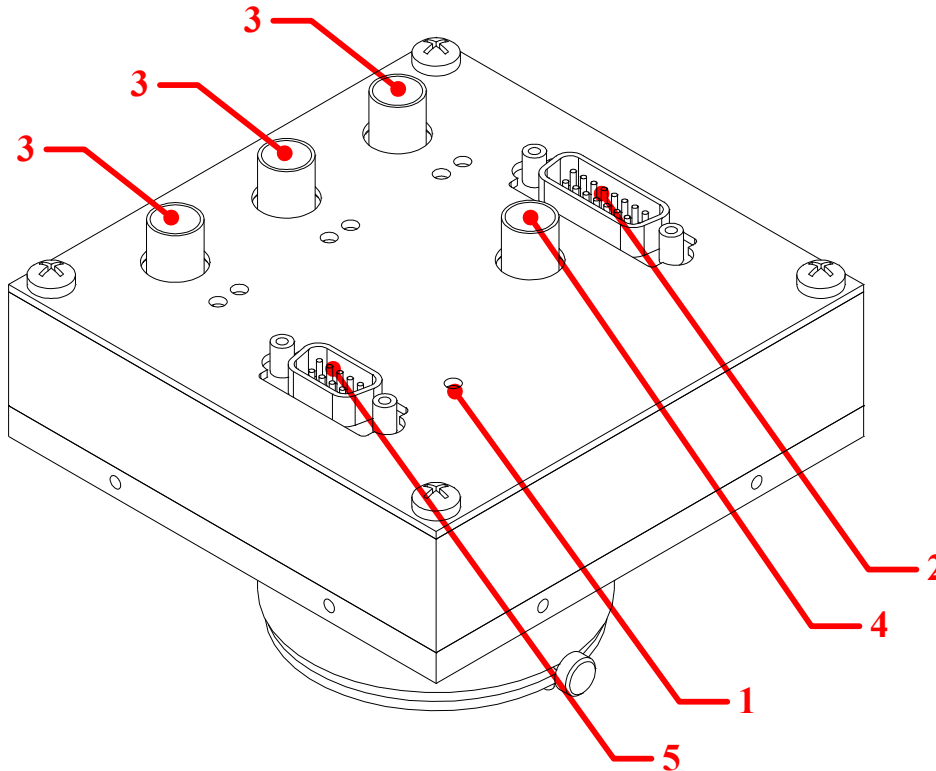

Figure 1 Connectors of the camera

Notes	
1	LED Status
2	Power & I/O connector
3	Analog BNC connector
4	Digital BNC connector
5	RS-232 connector

Table 3 connector information

2.1.1 Power & I/O Connector

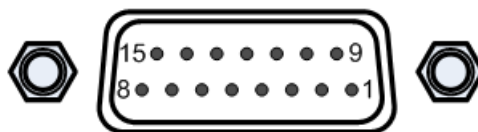

Figure 2 Power & I/O connector

No.	Signal	Dir	Function	No.	Signal	Dir	Function
1	SHIELD	—	Shield	—	—	—	
2	VDD	—	+12V DC IN	9	NC-	—	
3	GND	—	GND	10	GND	—	GND
4	NC	—	—	11	NC	—	
5	SYNC+	O	Sync Out +	12	SYNC-	O	Sync Out -
6	CLKOUT-	O	Clock Out -	13	CLKOUT+	O	Clock Out +
7	SYNCIN+	IN	Sync Input +	14	SYNCIN-	IN	Sync Input -
8	CLKIN-	IN	Clock Input -	15	CLKIN+	IN	Clock Input +

Table 4 Power & I/O Connector

**Information!**

GNDs are connected together inside to the Digital Ground of the camera. NC should not be connected.

**Information!**

All IO signals (SYNC, SYNCIN, CLKOUT, CLKIN) are RS-644/LVDS standard.

2.1.2 Analog & Digital BNC connector

There are total 4 standard BNC type connectors for analog & digital output

- 3 analog BNC connectors output Red/Green/Blue channel of CCD sensor signal with 0V-5V range
- The digital BNC output SYNC signal (same signal source with SYNC+/- RS-644) with 5V TTL format.

2.1.3 RS-232 connector

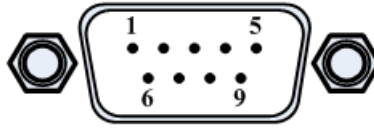



Figure 3 RS-232 Pin connection

DB9/Male Connector		
No.	Signal	Type
2	RXD	RS-232 Receive Line
3	TXD	RS-232 Transmit Line
5	GND	GND
1,4,6,7,8,9	NC	Not Connect

2.1.4 RS-232 communication format

- ✚ Duplex without handshaking.
- ✚ 9600 bauds, 8bit data, no parity bit, 1 stop bit.

2.1.5 Cables

	<p>Information! Recommend using twisted pair cables for all RS-644/LVDS Input and output signals, for longer transfer distance, the cable should meet the RS-644 standard requirements.</p>
---	--

	<p>Information! All analog outputs should use 75Ω coax axial cables for best signal quality.</p>
---	---

3. Camera functions and control

3.1 Serial camera configuration

Commands are based on ASCII protocol of the serial communication, the command syntax is:

Command=Parameter(CR)

- ✚ **Command:** one or more characters continued with a “=” character.
- ✚ **Parameter:** must be one or more characters within “0” to “9”.
- ✚ **(CR)** : Represent the “Enter” character (Hex value is **0x0D**), same for below.
- ✚ “Blanc” (or SPACE) character is not allowed in the command syntax.

Setting	Command	Parameter	Description
Integration Time	I=	0~65535	Integration time setting, valid for Internal Sync only, default value is 0.
Working Modes	M=	0	Internal Clock + Internal Sync, default
		1	Internal Clock + External Sync
		2	External Clock + Internal Sync
		3	External Clock + External Sync
Internal Clock Frequency	F=	0	20MHz Pixel Clock, default
		1	10MHz Pixel Clock
		2	5MHz Pixel Clock
		3	2.5MHz Pixel Clock
Clock Delay	D=	0	No Delay, default
		1	¼T Delay
		2	½T Delay
		3	¾T Delay
Reset Logic	T=	1	Reset the camera logic
Save Configuration	W=	1	Save current setting to memory, the setting will be restored after power up.

Table 5-Camera command list

Return String	Status	Description
<OK>(CR)	Successful	Operation Successful
<ERR><Syntax Error!>(CR)	Error	Blanc character detected, without “=” character, without command character(s) or parameter character(s).
<ERR><Invalid Command!>(CR)	Error	Unknown Command
<ERR><Invalid	Error	There are one or more of character is not

<i>Parameter!>(CR)</i>		within the “0” to “9” range
<i><ERR><Out of Range!>(CR)</i>	Error	Parameter is out of setting range
<i><ERR><Function Not Support!>(CR)</i>	Error	Setting a function that camera not support
<i><ERR><Internal Error!><ERR=n>(CR)</i>	Error	Internal Errors

Table 6 Camera return string

3.2 Internal & external clock

The camera could be set to use internal or external clock source. The output digital signal SYNC & CLOCKOUT should be like the figure below:

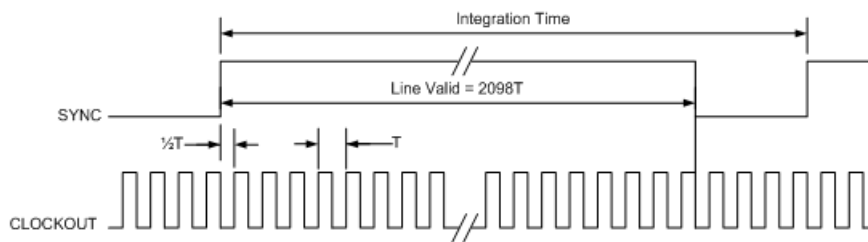



Figure 4 Digital output signal of the camera

With internal clock setting, user could also set 4 different CLKOUT frequencies:

Setting	CLKOUT Frequency	T Value
F=0	20MHz	50ns
F=1	10MHz	100ns
F=2	5MHz	200ns
F=3	2.5MHz	400ns

The camera also accept user input external clock to drive the CCD as desired frequency, note the input via CLKIN RS-644 input CLOCKIN frequency should be 4 times of the CLKOUT frequency you want to set, for example, if you need 2MHz of CLKOUT frequency, then the input clock frequency to the CLKIN input should be 8 MHz.

Signal	Description	MIN.	TYP.	MAX.
CLOCKIN	External input clock frequency	4MHz	—	80MHz
CLKOUT	Pixel clock rate	1MHz	—	20MHz

	<p>Information! Recommend using twisted pair cables for all RS-644/LVDS Input and Output signals, for longer transfer distance, the cable should be meet the RS-644 standard requirements.</p>
---	--

3.3 Working modes of camera

3.3.1 Internal sync mode

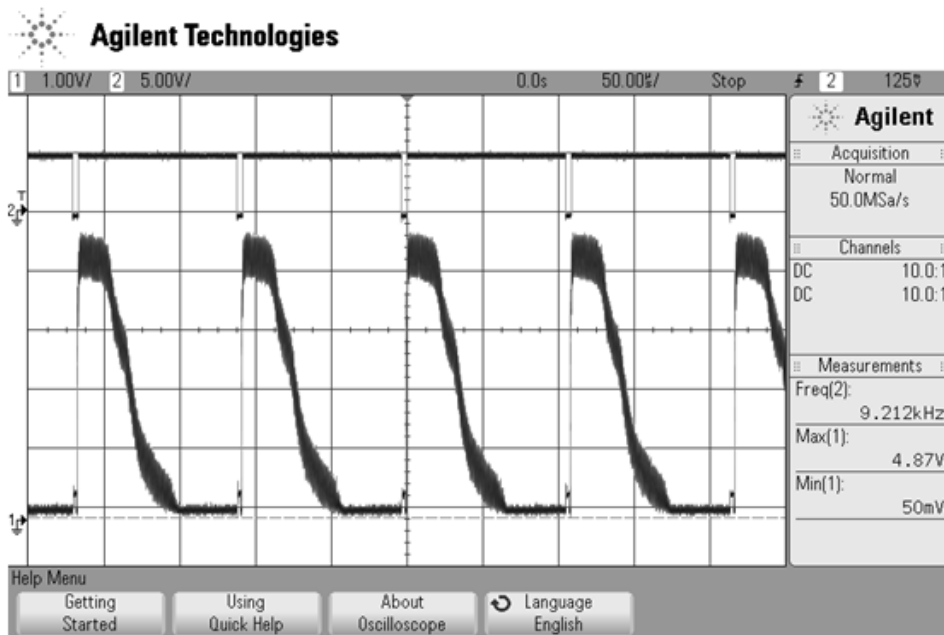
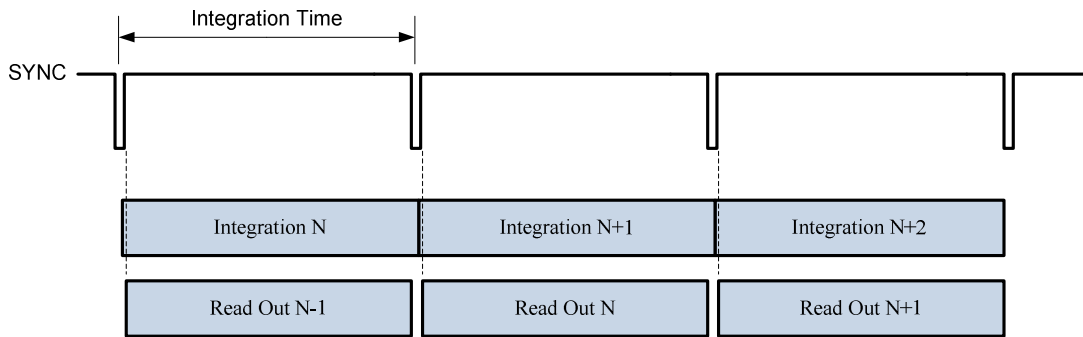

Figure 5 Internal sync mode

With internal sync setting (both for internal clock or external clock), the integration is controlled by camera's internal logic module, integration time could be set via "I" command.

3.3.2 Integration time for internal sync mode

For internal sync mode, integration time could be set via the “I” command, the actual integration time and line rate could be calculated using formula below:

$$\text{Integration Time} = (2170 + (I \times 16)) \times T \text{ (ns)}$$

$$\text{Line Rate} = \frac{10^9}{\text{Integration Time}} \text{ (Hz)}$$

Where I=value set via “I” command (value range is 0 – 65535), and T=pixel clock period according to the internal or external clock setting.

When using the internal clock with maximum 20 MHz pixel clock rate, the maximum and minimum line rate is:

$$\text{Line Rate}_{\text{MAX}} = \frac{10^9}{108500} \approx 9216 \text{ (Hz)}$$

$$\text{Line Rate}_{\text{MIN}} = \frac{10^9}{52536500} \approx 19 \text{ (Hz)}$$

3.3.3 External sync mode

For external sync mode setting, integration time will be controlled by the external input SYNC signal, and the internal integration setting via “I” command would be invalid in this mode.

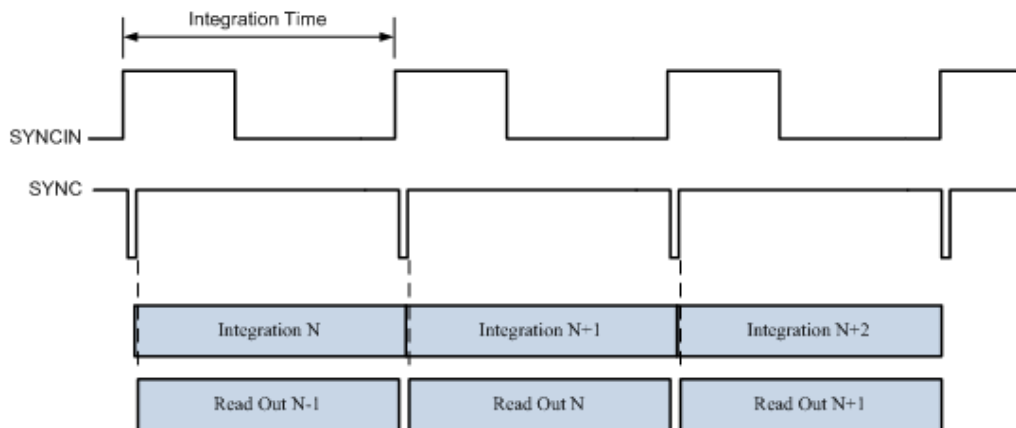

Figure 6 External sync mode

External SYNCIN signal should be a period pulse, the positive edge would trigger the internal integration control, and the SYNCIN period should be satisfying the formula below:

$$\text{SYNCIN Period (Integration Time)} \geq 2172 \times T \text{ (ns)}$$

3.4 Output clock delay

Due to the nature of CCD sensor, the output signal is not a regular continues analog signal, with each pixel reset for output register inside the CCD sensor, the output is a pulse like analog signal similar as figure below:

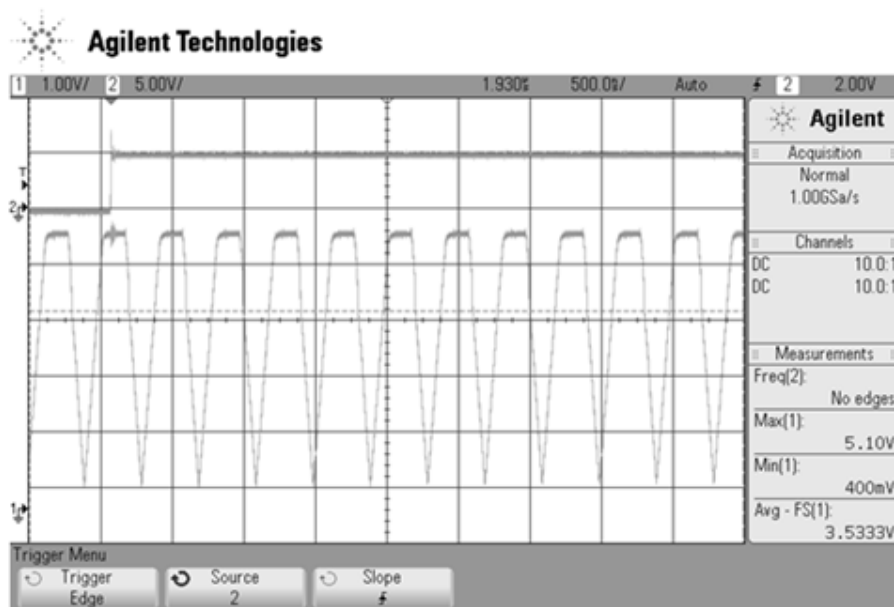
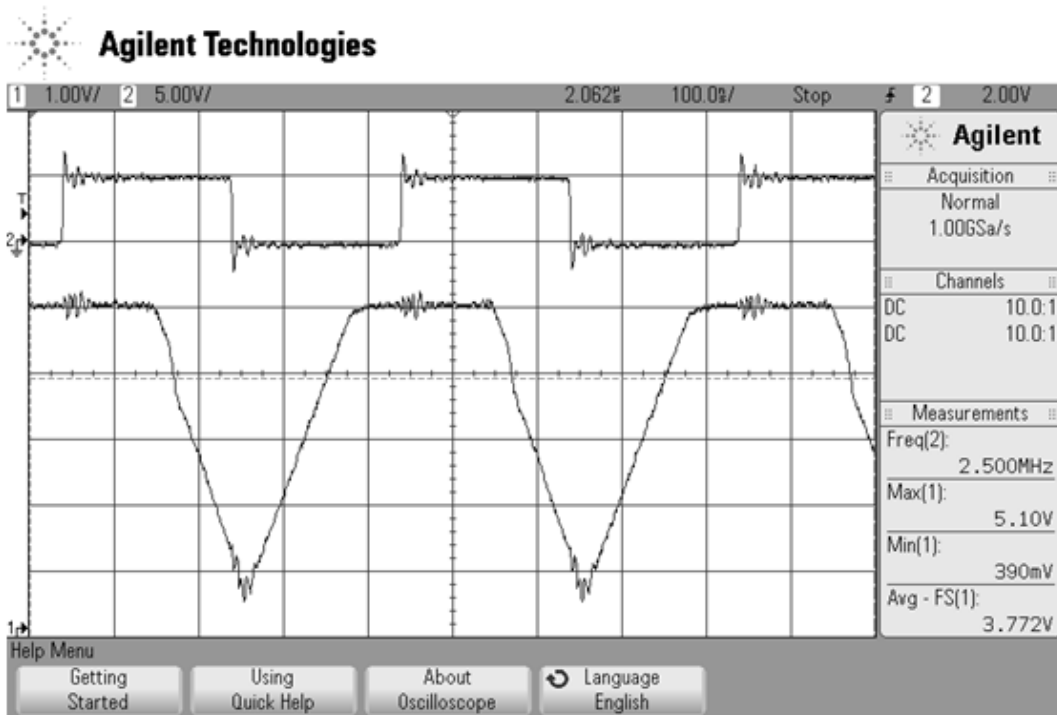
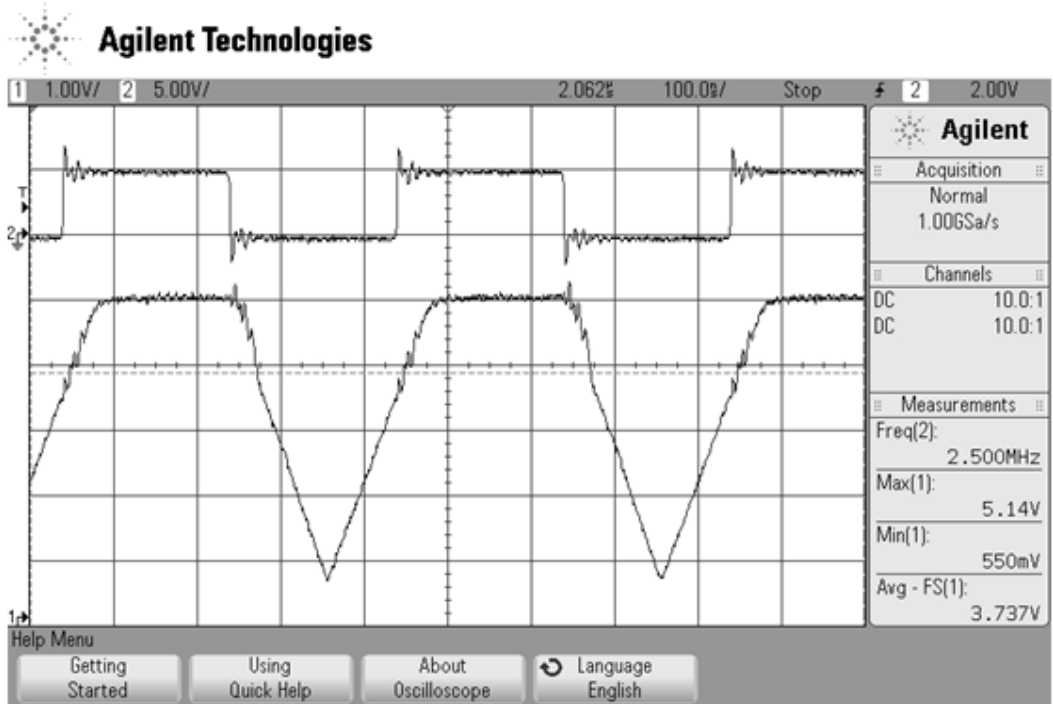

Figure 7 SYNC output vs. Analog output

This will need the clock output sample the right position of the analog output. The pixel output clock rate and the cable both will cause delay of the analog signals, so the camera could be set four step delay of the CLKOUT signal to obtain best sample position.

Users could use the “D” command to set the delay, from 0T to 0.75T with 0.25T step, below is the acquired image from the camera to explain the delay function (For the demo below, the 0.5T setting is the best position):



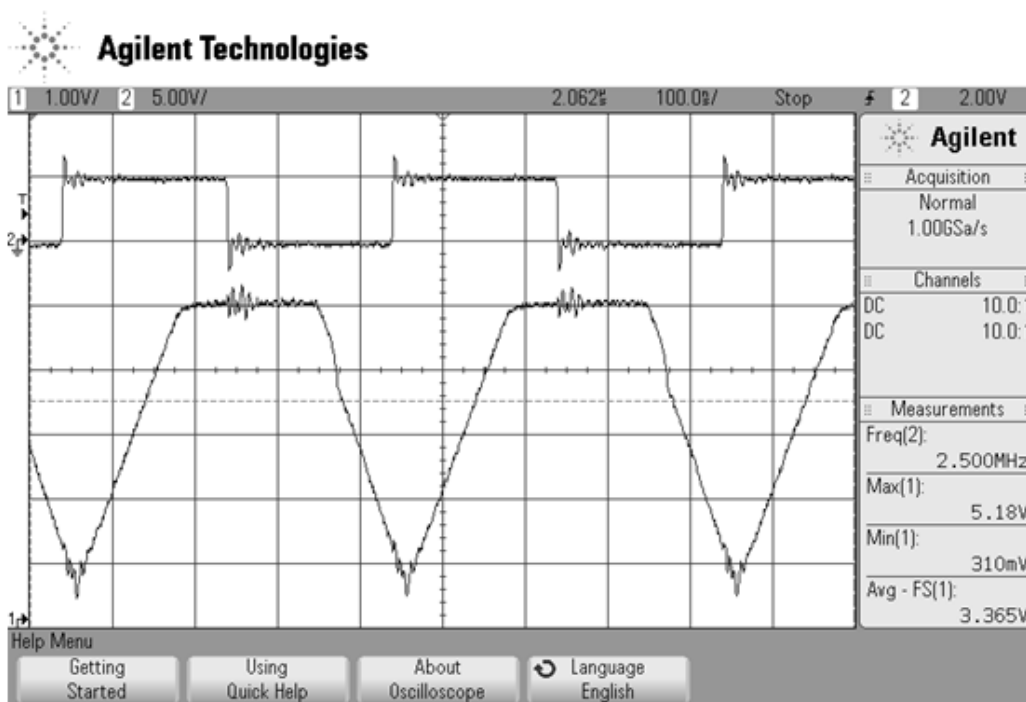
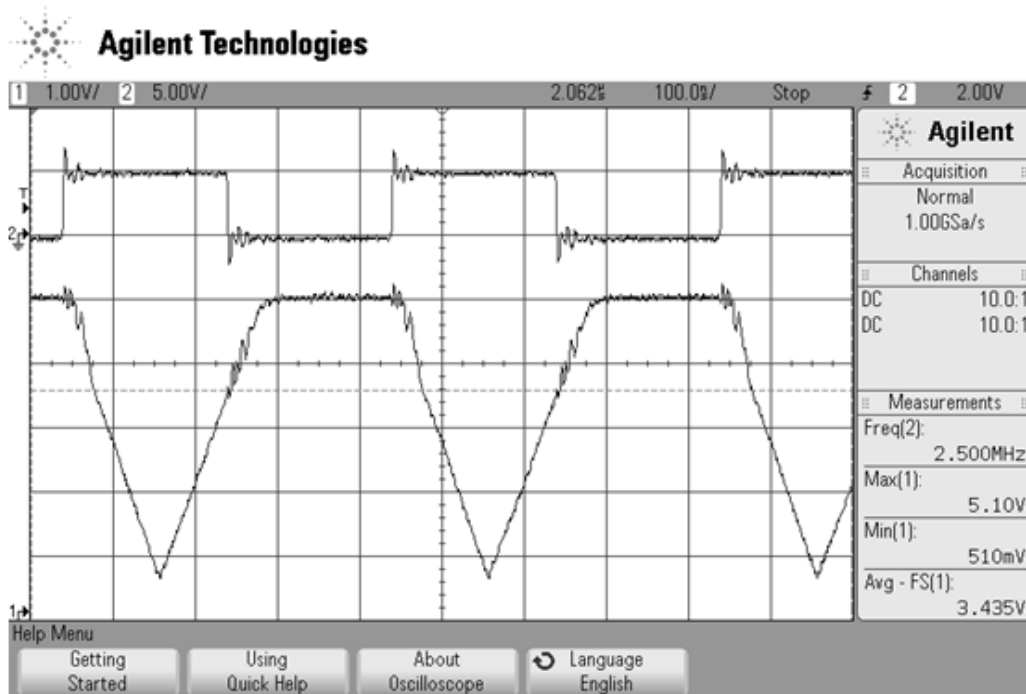



Figure 8 CLKOUT delay vs. Analog output (0T, 0.25T, 0.5T, 0.75T)

3.5 Camera reset & save configuration

Using “T=1” command to perform a internal logic reset of the camera.

	<p>Information! Recommend using reset command after changing the working mode or setting of internal clock frequency change.</p>
---	---

Using “W=1” command will store all current settings to internal memory, when the camera is power off and on again, the setting will automatic restore from the internal memory.

3.6 Gain & offset adjust

The camera has total 6 of potentiometers, 2 of each is pair for adjusting gain and offset of each color channel, please refer to below image for the position of each potentiometer.

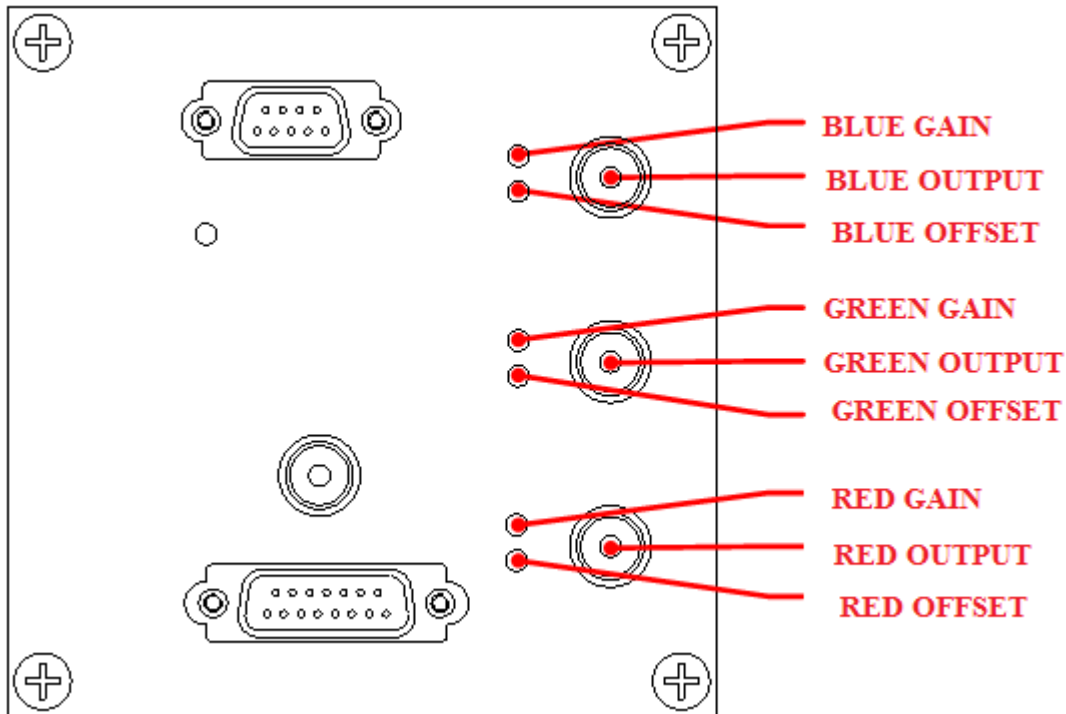



Figure 9 Gain and offset potentiometers

Potentiometer	Direction	Description
Gain	↻	Increase Gain (More sensitivity)
	↺	Decrease Gain (Less sensitivity)

Offset		Lower Offset (More black)
		Higher Offset (More white)



Information!
Default gain is setting to the lowest.



Information!
Increase the gain will also increase the noise of the camera output, but the total noise to signal (dB) ratio will not change apparently.

4. Mechanical

UNIT: mm

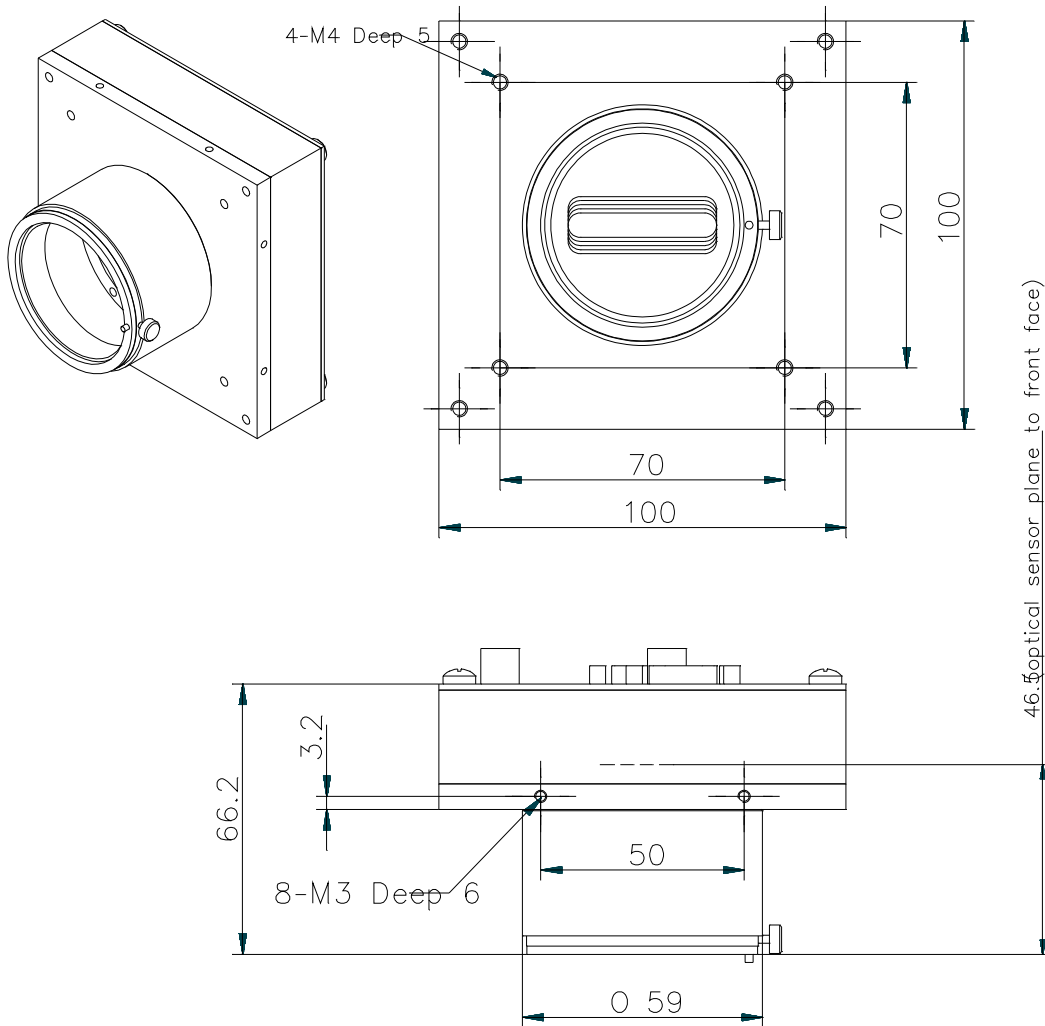

Figure 10 Mechanical dimensions of camera

	<p>Warning</p> <p>The lens should be Mount after removing the protection caps of the camera to avoid dust onto CCD's optic window.</p>
--	---

5. Ordering code

Model Number	Description
BMT-2098C-A	2098 Pixel CCD Colour Line Scan Camera
BMT-2098M-A	2098 Pixel CCD Monochrome Line Scan Camera

For more product information or inquiry, please contact

Balaji MicroTechnologies Pvt. Ltd.
(A Unit of B.B. Group of Companies)

Corporate Headquarter: New Delhi, India

Sales/business Operation: D-2/20, Sector-10 | DLF Faridabad-121006 |
Haryana, **INDIA**

Tel # +91-129-4006203 | +91-129-6561300

Email (For Overseas Sales): sales.overseas@balaji-microtechnologies.com

Email(For India Sales): sales.india@balaji-microtechnologies.com

Website: <http://www.balaji-microtechnologies.com/>