

SHIMANO
Nexus
INTER-8

SHIMANO NEXUS INTER-8 COASTER HUB

SG-8C20

SERVICE MANUAL

vol. 1



SHIMANO



Contents

The new standard in internal geared hubs	4
Technical Service Instructions SG-8C20, CJ-8S20, SL-8S20, BL-IM65	6
Troubleshooting Chart	12
Replacement of the internal unit	14
Disassembly of the internal unit	16
Assembly of the INTER-8 coaster hub	21
Cassette Joint & Measurement tool	28
NEXUS non-turn washers	30
Hub dimensions (O.L.D. and axle)	31
Spare parts list (SG-8C20)	32
Spare parts list (SL-8S20)	33
Spare parts list (CJ-8S40)	34
Spare parts list (BL-IM65)	35

SHIMANO Nexus INTER-8



The new standard in internal geared hubs

The NEXUS 8-speed system delivers a new level of design, quality and function. Our designers have updated the conventional internal hub with a refreshing new design inspired by the concepts of beauty, innovation and integrity. Many technical advances have been achieved, like incorporating Shimano's unique gear change support mechanism that makes a real low effort shifting.

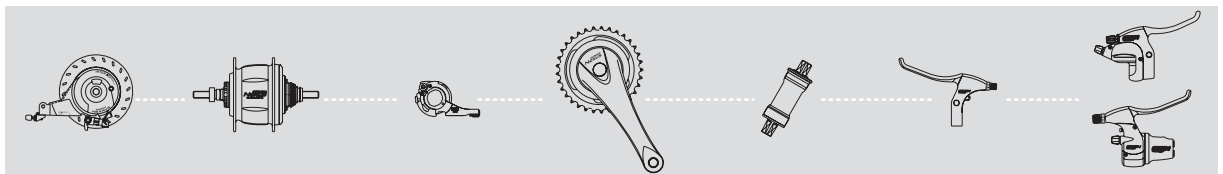

BR-IM70-R
Roller Brake

SG-8R25
Premium version
SG-8R20
Roller Brake
SG-8C20
Coaster Brake
SG-8R25-VS
SG-8R20-VS
V-Brake

Small Parts Set

FC-NX60
33/38T
FC-NX80
HOLLOWTECH
Crankset

BB-UN25

BL-IM65
3-finger
Brake lever
BL-IM60
4-finger
Brake lever

ST-8S20
3-finger
Brake lever
SL-8S20
SB-8S20
4-finger
Brake lever

INTER **M** MULTI
CONDITION

SG-8R25 Premium Version for Roller Brake

SG-8R20 Roller Brake Version

SG-8R25-VS V-Brake Version

SG-8R20-VS V-Brake Version

SG-8C20 Coaster Brake Version

• Gear Change Support Mechanism

Shimano's gear change support mechanism uses pedaling power to aid down-shifting. The result is fast and accurate down-shifting with an exceptionally light feeling. Mechanical shifting resistance is notably reduced so shifting is not affected under high loads.

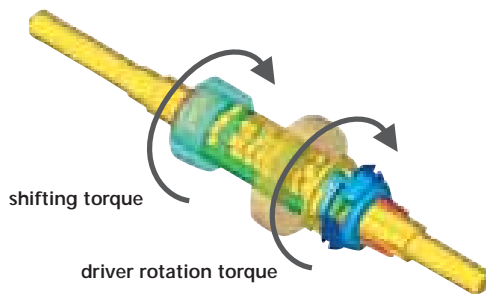

• Smooth Gear Change

The smaller idling angle realizes shockless smoother shifting for stressless comfortable gear change.

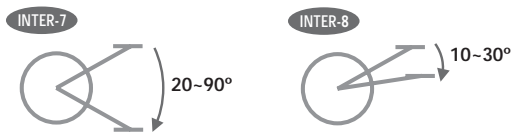

• Smoother Rotation

Shimano's precise manufacturing abilities construct an internal hub that rotates with significantly less drag than previous models.

• Close Ratio Wider Range

The INTER-8 hub has increased its gear ratio to 307%, compared to 244% of the INTER-7 hub.

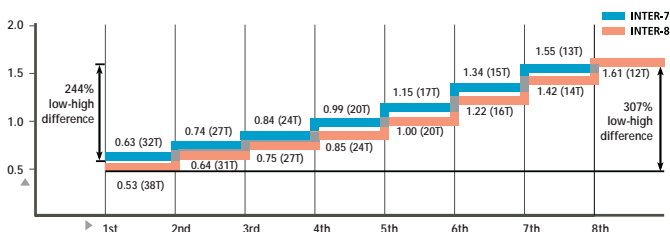

• Better Sealing

The INTER-8 hub has adopted a labyrinth seal system that shuts out water and dirt to extend the service life and maintain smooth shifting in all circumstances. Optionally a waterproof dust cap can be installed ex factory on the non-drive side before shipment, in case you wish to use the hub in combination with a separate brake system such as V-Brakes.



• Robust Construction

Durable planetary and step-up gear sets assure long trouble-free service.

ST-8S20 Shifter with 3-finger Brake Lever

BL-IM65 3-finger Brake Lever

SB-8S20 Shifter with 4-finger Brake Lever

SL-8S20 Shifter

BL-IM60 4-finger Brake Lever

• Fast and Light Shifting

In combination with the Gear Change Support Mechanism the shifting action is quick and light even during hight pedaling loads.

• Easy-to-read Gear Indicator

Larger more visible indicator numbers make gear positions easier to read. Additionally, indicator symbols help to understand the direction of shifting progression.

• INTER-8 (SG-8C20): 30% more braking power compared to INTER-7

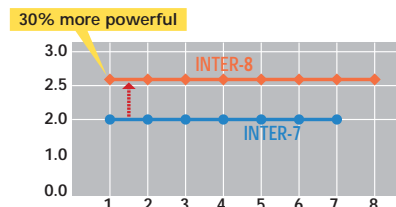

General Safety Information

⚠ WARNING – To avoid serious injuries:

- It is important to completely understand the operation of your bicycle's brake system. Improper use of your bicycle's brake system may result in a loss of control or an accident, which could lead to severe injury. Because each bicycle may handle differently, be sure to learn the proper braking technique (including bicycle control characteristics) and operation of your bicycle. This can be done by consulting your professional bicycle dealer and the bicycle owner's manual, and by practicing your riding and braking technique.
- When securing the brake arm to the frame, be sure to use a brake arm clip that matches the size of the chainstay, and securely tighten them with the clip screw and clip nut to the specified tightening torque. Use a lock nut with a nylon insert (self-locking nut) for the clip nut. It is recommended that standard Shimano parts be used for the clip screw, clip nut and brake arm clip. In addition, use a brake arm clip that matches the size of the chainstay. If the clip nut comes off the brake arm, or if the clip screw or brake arm clip becomes damaged, the brake arm may rotate on the chainstay and cause the handlebars to jerk suddenly, or the bicycle wheel may lock and the bicycle may fall over, causing serious injury.
- When installing the hub to the frame, be sure to install the correct non-turn washers to the left and right sides, and securely tighten the hub nuts to the specified torques. If the non-turn washers are installed to one side only, or if the hub nuts are not tightened sufficiently, the non-turn washer may fall out, which could cause the hub axle to rotate and the cassette joint to turn. This may then cause the handlebars to be accidentally pulled by the shifting cable, and an extremely serious accident could result.
- Obtain and read the service instructions carefully prior to installing the parts. Loose, worn, or damaged parts may cause serious injury to the rider. We strongly recommend only using genuine Shimano replacement parts.
- Check that the wheels are fastened securely before riding the bicycle. If the wheels are loose in any way, they may come off the bicycle and serious injury may result.
- Read these Technical Service Instructions carefully, and keep them in a safe place for later reference.

⚠ CAUTION – To avoid serious injuries:

- Avoid continuous application of the brakes when riding down long slopes, as this will cause the internal brake parts to become very hot, and this may weaken braking performance. It may also cause a reduction in the amount of brake grease inside the brake, and this can lead to problems such as abnormally sudden braking.
- Spin the wheel and confirm that the braking force of the coaster brake is correct.
- If the brakes are used frequently, the brake drum may become hot. Do not touch the brake drum for at least 30 minutes after you finish riding the bicycle.

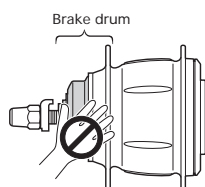

NOTE:

- You can shift gears while pedaling, but on rare occasions the pawls and ratchet inside the hub may produce some noise afterwards as part of normal gear shifting operation.
- The CJ-8S20 cassette joint should only be used with sprockets from 16T to 23T.
- If the wheel becomes stiff and difficult to turn, you should replace the brake shoes or lubricate with grease.
- Do not apply any lubricant to the inside of the hub, otherwise the grease will come out.
- You should periodically wash the sprockets in a neutral detergent and then lubricate them again. In addition, cleaning the chain with neutral detergent and lubricating it can be an effective way of extending the useful life of the sprockets and the chain.
- If the chain keeps coming off the sprockets during use, replace the sprockets and the chain.
- Parts are not guaranteed against natural wear or deterioration resulting from normal use.
- For maximum performance we highly recommend Shimano lubricants and maintenance products.
- For any questions regarding methods of handling or adjustment, please contact the place of purchase.

SG-8C20
CJ-8S20

INTER-8 Hub
with Coaster Brake
Cassette Joint

Technical Service Instructions



Be sure to read these service instructions in conjunction with the service instructions for the INTER-8 shifting lever before use.

Installation of the cassette joint to the hub

1. Install the driver cap to the driver on the right side of the hub body.

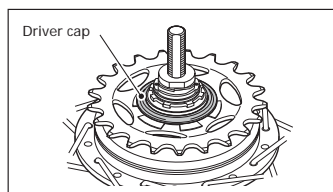
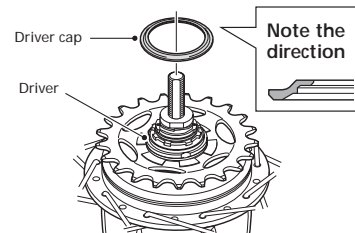

2. Turn the cassette joint pulley in the direction of the arrow in the illustration to align the red ● marks on the pulley and the bracket. With the cassette joint in this condition, install it so that the red ● mark on the cassette joint is aligned with the red ● mark on the right side of the hub body.

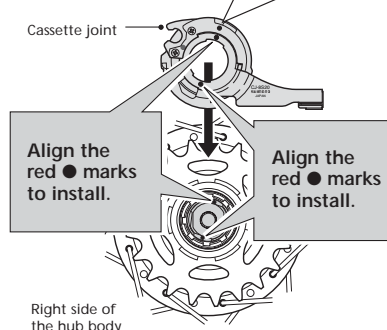
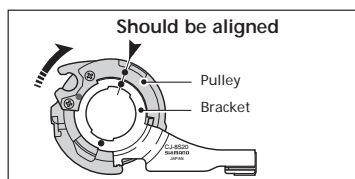

Right side of the hub body

3. 1) Secure the cassette joint to the hub with the cassette joint fixing ring. When installing the cassette joint fixing ring, align the yellow ● mark with the yellow ● mark on the cassette joint pulley.

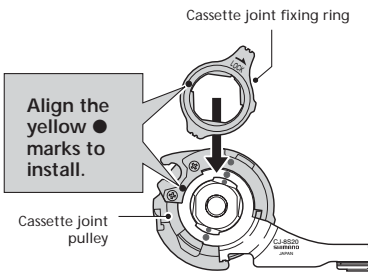

3. 2) After installing the cassette joint fixing ring, turn it 45° clockwise.

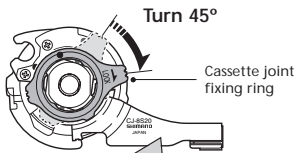

Fit the cassette joint bracket securely.

Installation of the hub to the frame

1. Mount the chain on the sprocket, and then set the hub axle into the fork ends.

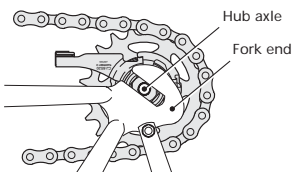

2. Place the non-turn washers onto the right side and left side of the hub axle. At this time, turn the cassette joint so that the projecting parts of the non-turn washers fit into the grooves of the fork ends. If this is done, the cassette joint can be installed so that it is almost parallel to the chainstay.

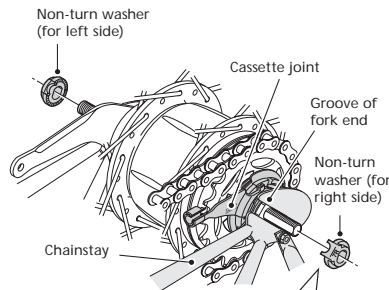

- Different types of left and right non-turn washers are available for use with standard and reversed fork ends. Use whichever non-turn washers are suitable.

Fork end	Non-turn washer		Size
	Mark/Color		
	Right	Left	
Standard	5R/Yellow	5L/Brown	$\theta \leq 20^\circ$
	7R/Black	7L/Gray	$\theta \leq 38^\circ$
Reversed	6R/Silver	6L/White	$\theta = 0^\circ$
Reversed (full chain case)	5R/Yellow	5L/Brown	$\theta = 0^\circ$



- The projecting parts should be on the fork end side.
- Install the non-turn washers so that the projecting parts are securely in the fork end grooves on either side of the hub axle.

3. Take up the slack in the chain and secure the wheel to the frame with the cap nuts.

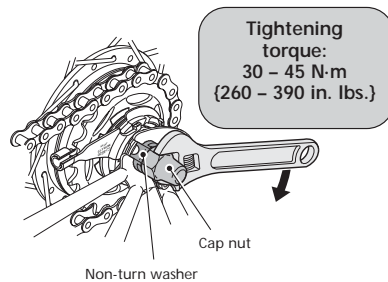

4. Fix the brake arm securely to the chainstay with the brake arm clip.

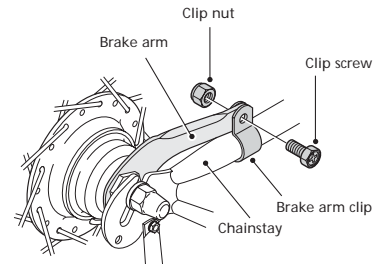

NOTE:

- When installing the brake arm clip, securely tighten the clip screw while holding the clip nut with a 10 mm spanner.

Tightening torque:
2 - 3 N·m {17 - 26 in. lbs.}

- After installing the brake arm clip, check that the clip screw protrudes about 2 - 3 mm from the surface of the clip nut.

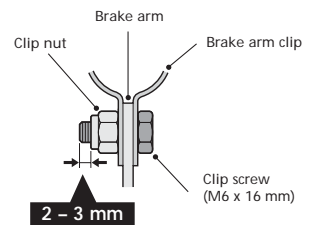

5. Before using the Coaster Brake, check that the brake works properly and that the wheel turns smoothly.

General Safety Information



SI-6FD0A

⚠ WARNING – To avoid serious injuries:

- Obtain and read the service instructions carefully prior to installing the parts. Loose, worn, or damaged parts may cause serious injury to the rider. We strongly recommend only using genuine Shimano replacement parts.
- It is important to completely understand the operation of your bicycle's brake system. Improper use of your bicycle's brake system may result in a loss of control or an accident, which could lead to severe injury. Because each bicycle may handle differently, be sure to learn the proper braking technique (including brake lever pressure and bicycle control characteristics) and operation of your bicycle. This can be done by consulting your professional bicycle dealer and the bicycle's owners manual, and by practicing your riding and braking technique.
- These brake levers are equipped with a mode switching mechanism to make them compatible with cantilever brakes and Roller Brakes or V-Brakes with power modulator.

If the incorrect mode is selected it may cause either excessive or insufficient braking force to occur, which could result in dangerous accidents.

Be sure to select the mode in accordance with the instructions given in the table below.

Mode position	Applicable brake
<p>C/R position</p>  <p>The C indicates the mode position for compatibility with cantilever brakes.</p> <p>The R indicates the mode position for compatibility with Roller Brakes.</p>	<ul style="list-style-type: none"> Cantilever brakes Roller Brakes
<p>V position</p>  <p>The V indicates the mode position for compatibility with V-Brakes with power modulator.</p>	<ul style="list-style-type: none"> V-Brakes with power modulator

Use the brake levers with mode switching mechanism in the combinations given above.

- Read these Technical Service Instructions carefully, and keep them in a safe place for later reference.

⚠ CAUTION – To avoid serious injuries:

Be sure to shift the lever one gear at a time, and reduce the force being applied to the pedals during shifting. If you try to force operation of the shifting lever while the pedals are being turned strongly, your feet may come off the pedals and the bicycle may topple over, which could result in serious injury.

NOTE:

- For maximum performance we highly recommend Shimano lubricants and maintenance products.
- Parts are not guaranteed against natural wear or deterioration resulting from normal use.

SL-8S20 Revo-shift Lever
BL-IM65 Brake Lever
CJ-8S20 Cassette Joint

Technical Service Instructions



Be sure to read these service instructions in conjunction with the service instructions for the Inter-8 hub before use.

Revo-shift lever operation

Turn the Revo-shift lever to shift to each of the eight gears.

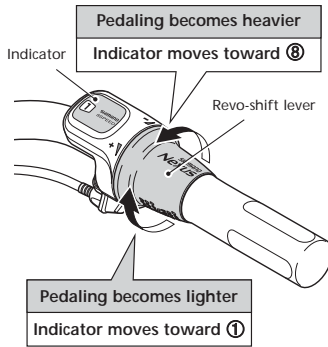

Installation of the lever

Install the lever as shown in the illustration.

In case of using Shimano half grip, the straight section of the handlebar should be 166 mm or more in length; attach the Revo-shift lever to this straight section.

Leave a gap of 0.5 mm between the Revo-shift lever and the half grip.

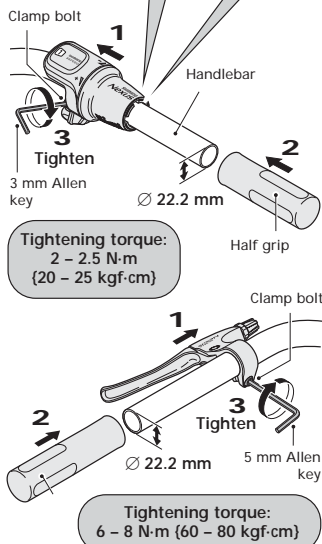

Disconnecting the shifting cable when removing the rear wheel from the frame

Disconnect the cable from the cassette joint when removing the rear wheel from the frame.

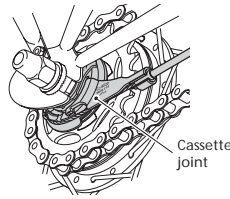

1. Set the Revo-shift lever to ①

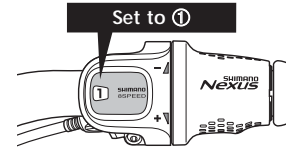

2. Pull the outer casing out from the outer casing holder of the cassette joint, and then remove the inner cable from the slit in the bracket.

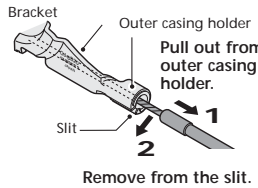

3. Remove the inner cable fixing bolt unit from the cassette joint pulley.

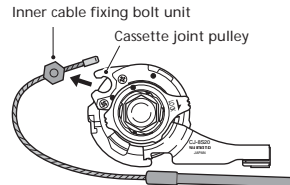

If it is difficult to pull the outer casing out from the outer casing holder of the cassette joint, insert a 2 mm Allen key or a #14 spoke into the hole in the cassette joint pulley, and then turn the pulley to loosen the inner cable. Then remove the inner cable fixing bolt unit from the pulley first, and after this remove the outer casing from the outer casing holder.

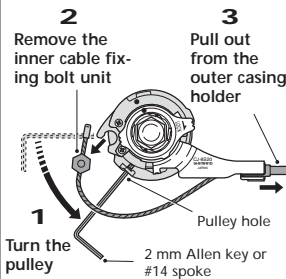

NOTE:
If reusing the cable, refer to steps 7 to 9 in "Installation of the shifting cable".

Installation of the shifting cable

Use a shifting cable with one inner cable drum.
 Cable with one inner cable drum / SIS-SP40 (4 mm dia.)



1. Set the Revo-shift lever to ①

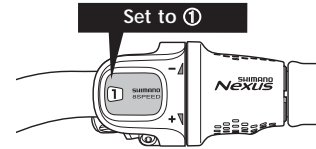

Revo-shift lever side

2. Loosen the cover fixing screw, and then remove the upper cover.

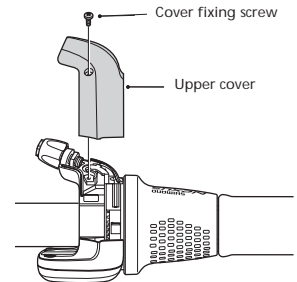

3. Pass the inner cable from the hole in the winder unit through the hole in the cable adjustment bolt. Next, insert the inner cable into the groove of the cable guide, and pull the inner cable so that the inner cable drum fits into the recess in the winder unit.

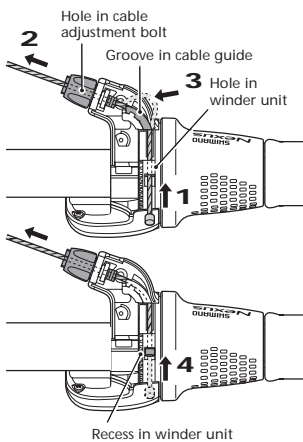

4. Replace the upper cover and tighten the cover fixing screw.

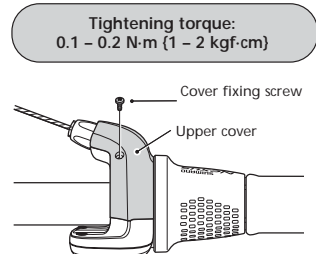

5. Pass the inner cable through the SIS-SP40 outer casing through the end with the plastic cap.

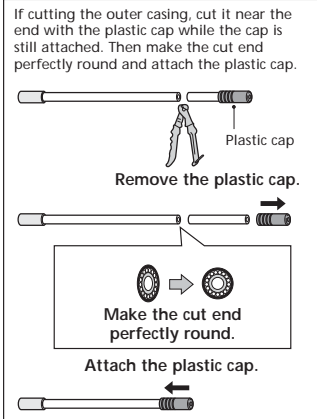
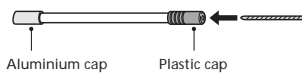

■ Cassette joint side

6. After checking that the end of the outer casing is sitting securely in the cable adjustment bolt of the Revoshift lever, attach the inner cable fixing bolt unit to the inner cable.

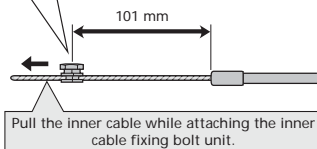
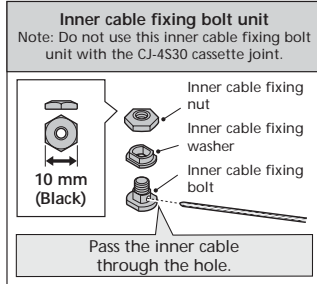

Tightening torque:
4 - 6 N·m (40 - 60 kgf·cm)

7. Bring the cable around to the cassette joint pulley, hold so that the inner cable fixing nut is facing to the outside (toward the fork end), and then slide the flats part of the inner cable fixing washer into the gap in the pulley.

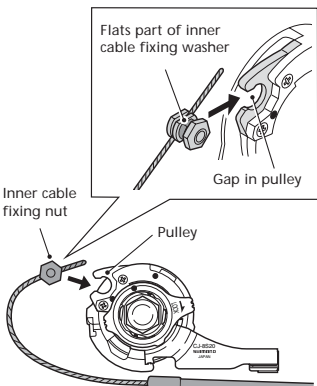

8. Turn the cable 60° counterclockwise and attach it to the hook.

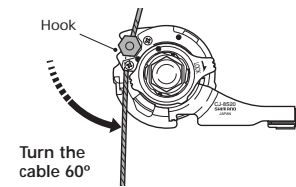

9. Attach the inner cable to the pulley as shown in the illustration, pass the inner cable through the slit in the cassette joint bracket, and then insert the end of the outer casing securely into the outer casing holder.

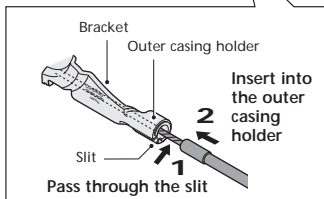
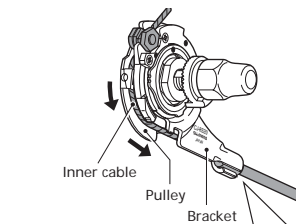

If first inserting the outer casing into the outer casing holder is easier, then first insert the outer casing into the outer casing holder, and then insert a 2 mm Allen key or a #14 spoke into the hole in the cassette joint pulley, and then turn the pulley so that the inner cable fixing bolt unit fits into the gap in the pulley.

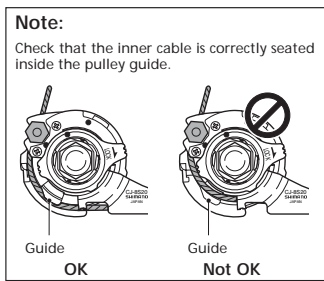
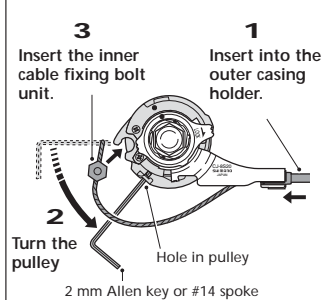

10. Secure the cable to the frame with the outer casing bands.

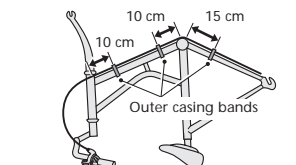

Adjusting the cassette joint

1. Set the Revoshift lever to ④. Check to be sure that the yellow setting lines on the cassette joint bracket and pulley are aligned at this time.

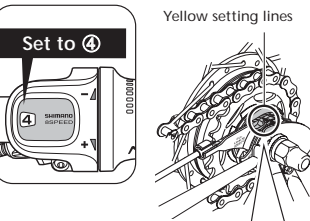

The yellow setting lines on the cassette joint are located in two places. Use the one that is easiest to see.

When bicycle is standing up

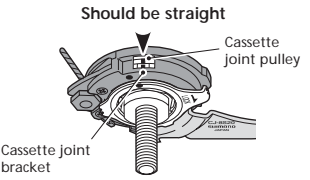

When bicycle is upside down

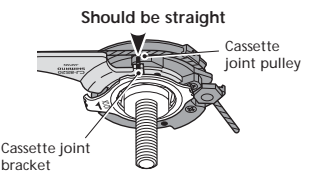

If the yellow setting lines are not aligned, turn the cable adjustment bolt of the Revoshift lever to align the setting lines. After this, move the Revoshift lever once more from ④ to ① and then back to ④, and then recheck to be sure that the yellow setting lines are aligned.

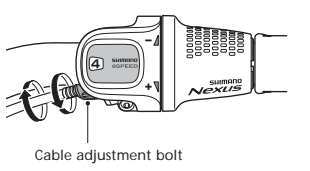

2. After adjusting the cassette joint, cut off the excess length of inner cable and then install the inner end cap.

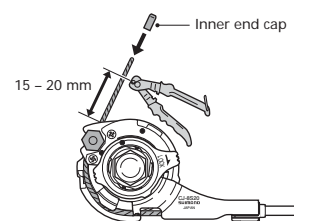

General Safety Information

⚠ WARNING

- To avoid serious injuries:
- Obtain and read the service instructions carefully prior to installing the parts. Loose, worn, or damaged parts may cause serious injury to the rider. We strongly recommend only using genuine Shimano replacement parts.
- Read these Technical Service Instructions carefully, and keep them in a safe place for later reference.

NOTE:

- The CJ-8S40 cassette joint should only be used with sprockets from 16T to 23T.
- When lubricating the chain or the sprockets, be careful not to get any oil on the rubber bellows or the rubber cover of the cassette joint.
- For maximum performance we highly recommend Shimano lubricants and maintenance products.
- Parts are not guaranteed against natural wear or deterioration resulting from normal use.

SI-74Y0A

CJ-8S40

Cassette Joint

Technical Service Instructions

Installation of the cassette joint

Refer to the Service Instructions for the INTER-8 hub for details on installation of the cassette joint to the hub and installation of the non-turn washer.

Note:

- Different types of left and right non-turn washers are available for use with standard and reversed fork ends. Use whichever non-turn washers are suitable.

Fork end	Non-turn washer		Size
	Mark/Color		
	Right	Left	
Standard	5R/Yellow	5L/Brown	$\theta \leq 20^\circ$
	7R/Black	7L/Gray	$\theta \leq 38^\circ$
Reversed	6R/Silver	6L/White	$\theta = 0^\circ$
Reversed (full chain case)	5R/Yellow	5L/Brown	$\theta = 0^\circ$

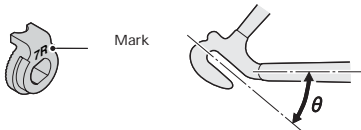

- The projecting parts should be on the fork end side.
- Install the non-turn washers so that the projecting parts are securely in the fork end grooves on either side of the hub axle.

Installation of the shifting cable

Use a shifting cable with one inner cable drum. SIS-SP (4 mm or 5 mm dia.)

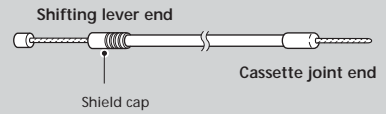

Note: Make sure that the shield cap is at the shifting lever end.

■ Shifting lever side

1. Connect the shifting cable to the shifting lever.

Refer to the Service Instructions which are provided with the INTER-8 shifting lever.

■ Cassette joint side

2. Set the shifting lever to ①.

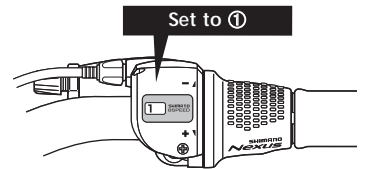

3. Install the rubber cover and rubber bellows to the outer casing holder.

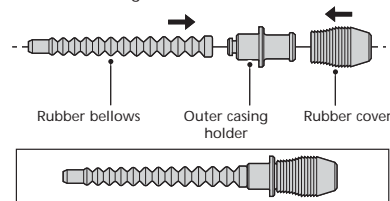

4. Wipe away any grease which may be on the inner cable, and then pass the inner cable through the rubber bellows. After this, insert the outer casing into the rubber cover and set it into the outer casing holder.

Use a new inner cable. Do not use a cable which has had the end cut off.

Be careful of the inner cable end.



- 1) While holding the end of the rubber bellows, insert the inner cable. Be careful not to pierce the rubber bellows with the end of the inner cable at this time.

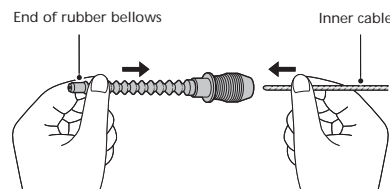

- 2) Slide the rubber bellows onto the inner cable.

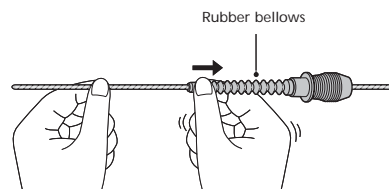

Disconnect the cable from the cassette joint when removing the rear wheel from the frame.

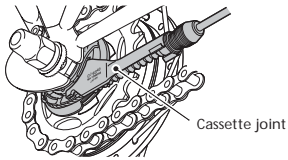

1. Set the shifting lever to ①.

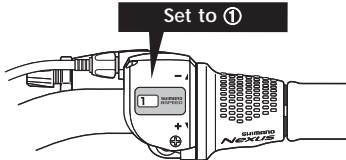

2. Hold the rubber cover and pull the outer casing holder out from the outer casing holder section of the cassette joint. Then remove the inner cable attached to the rubber bellows from the slit in the bracket. Be careful not to damage the rubber bellows at this time.

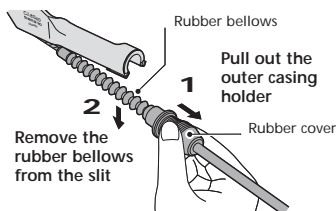

Note: Do not remove the cable by pulling the outer casing.

3. Remove the inner cable fixing bolt unit from the cassette joint pulley.

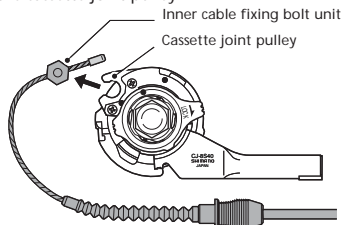

If it is difficult to pull the outer casing holder out from the outer casing holder section of the cassette joint, insert a 2mm Allen key or a #14 spoke into the hole in the cassette joint pulley, and then turn the pulley to loosen the inner cable. Then remove the inner cable fixing bolt unit from the pulley first, and after this remove the outer casing holder from the outer casing holder section.

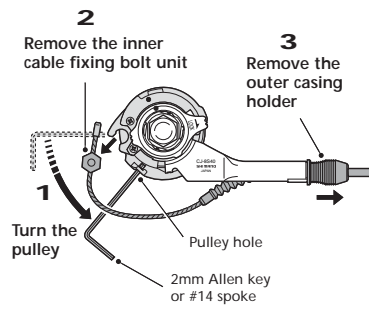

Note: If reusing the cable, refer to steps 6 to 8 in "Installation of the shifting cable".

- 3) Push the outer casing on so that it securely touches the outer casing holder.

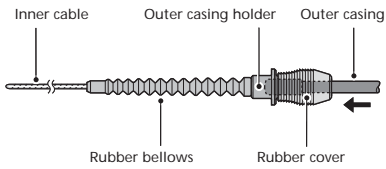

5. After checking that the end of the outer casing is sitting securely in the cable adjustment bolt of the shifting lever, attach the inner cable fixing bolt unit to the inner cable.

Inner cable fixing bolt unit

Note: Do not use this inner cable fixing bolt unit with the CJ-4S30 cassette joint.

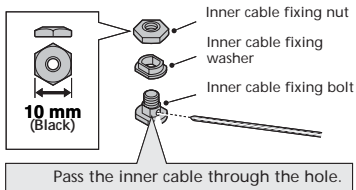

Pass the inner cable through the hole.

127 mm

63 mm or less

Pull the inner cable while attaching the inner cable fixing bolt unit.

Tightening torque:

4 - 6 N·m (40 - 60 kgfcm)

6. Bring the cable around to the cassette joint pulley, hold so that the inner cable fixing nut is facing to the outside (toward the fork end), and then slide the flats part of the inner cable fixing washer into the gap in the pulley.

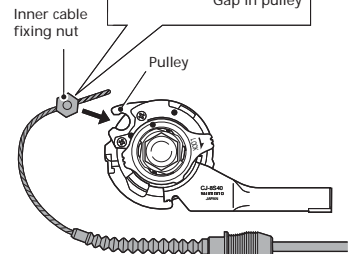
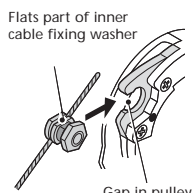

7. Turn the cable 60° counterclockwise and attach it to the hook.

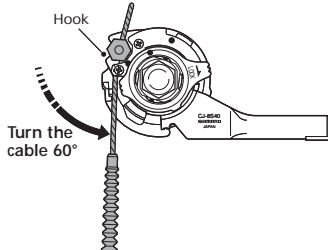

8. Attach the inner cable to the pulley as shown in the illustration, pass the part of the inner cable which has the rubber bellows attached through the slit in the cassette joint bracket, and then insert the outer casing holder securely into the outer casing holder section. Be careful not to damage the rubber bellows at this time.

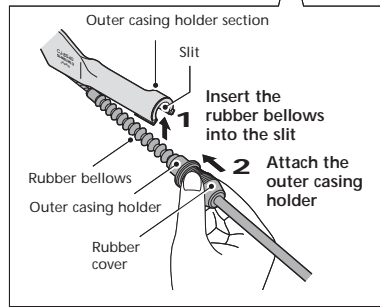
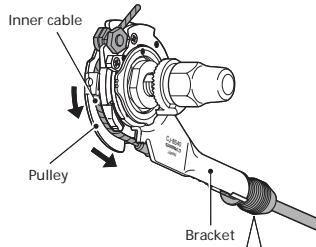

If first inserting the outer casing holder into the outer casing holder section of the cassette joint is easier, then first insert the outer casing holder into the outer casing holder section of the cassette joint, and then insert a 2mm Allen key or a #14 spoke into the hole in the cassette joint pulley, and then turn the pulley so that the inner cable fixing bolt unit fits into the gap in the pulley.

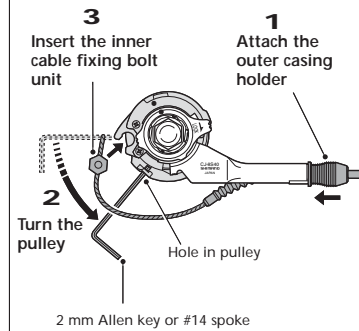

Note: Check that the inner cable is correctly seated inside the pulley guide.

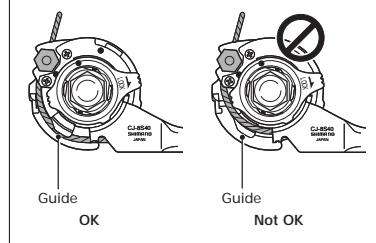

9. Secure the cable to the frame with the outer casing bands.

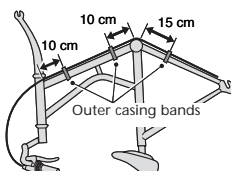

Adjusting the cassette joint

1. Set the shifting lever to ④. Check to be sure that the yellow setting lines on the cassette joint bracket and pulley are aligned at this time.

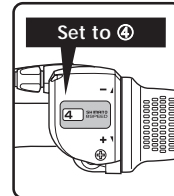

Yellow setting lines

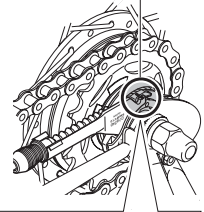

The yellow setting lines on the cassette joint are located in two places. Use the one that is easiest to see.

When bicycle is standing up

Should be straight

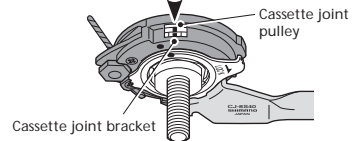

When bicycle is upside down

Should be straight

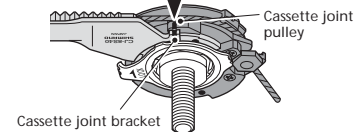

If the yellow setting lines are not aligned, turn the cable adjustment bolt of the shifting lever to align the setting lines. After this, move the shifting lever once more from ④ to ① and then back to ④, and then re-check to be sure that the yellow setting lines are aligned.

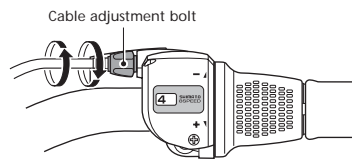

2. After adjusting the cassette joint, cut off the excess length of inner cable and then install the inner end cap.

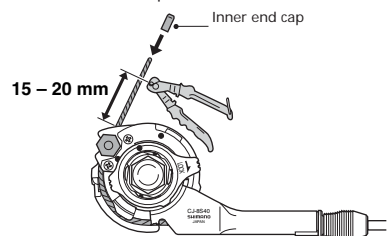

Troubleshooting Chart

SHIMANO NEXUS INTER-8 Coaster Hub

SG-8C20

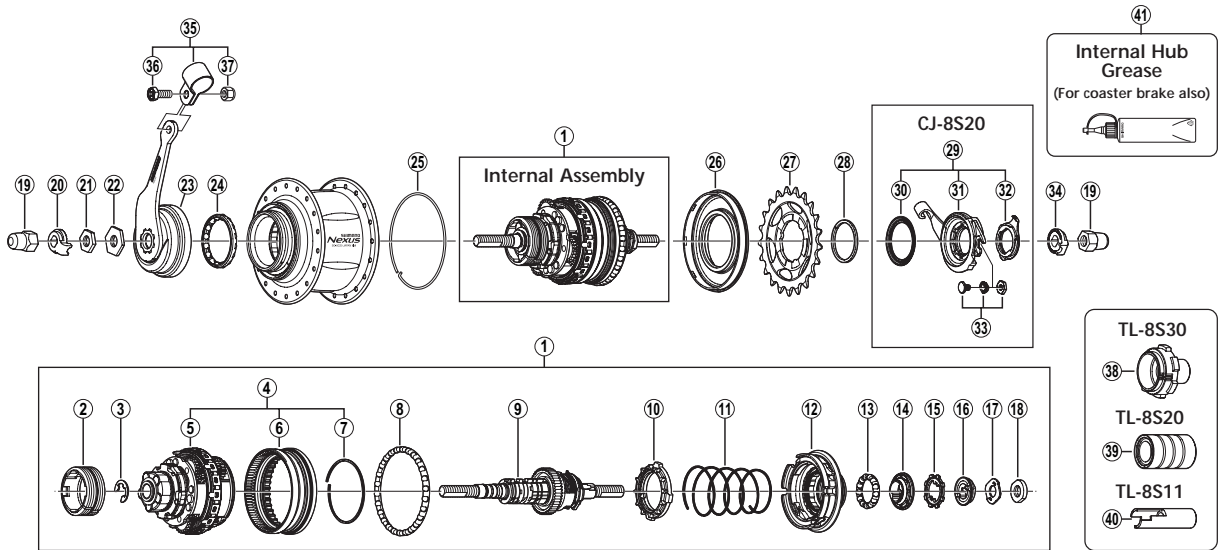

Same treatment of 8R20

Trouble condition			Remedy	
Abnormal noise occurs.	Cable is incorrectly adjusted.			<p>Set the shift lever to 4th. Then turn the cable adjusting barrel to align the red setting lines on the cassette joint bracket and pulley.</p> <p>Shift down to the 1st gear, up to the 4th again and recheck the adjustment.</p>
Abnormal noise still occurs after adjusting cable.	While shifting	Shifting position	1 ← → 2	Replace the hub axle unit and carrier unit.
			2 ← → 3	
			3 ← → 4	
			6 ← → 7	
		7 ← → 8		
		5 ← → 6	Replace the hub axle unit, clutch unit and carrier unit.	
	While pedaling	Shifting position	All	Replace the driver unit, hub axle unit and carrier unit.

Trouble condition		Remedy
Gear shift is not possible.	Cable is incorrectly adjusted.	Set the shift lever to 4th. Then turn the cable adjusting barrel to align the red setting lines on the cassette joint bracket and pulley.
	Remove the wheel from the frame and check whether gear shifting is possible.	Gear shifting is possible: When the shifting lever doesn't operate.
		Gear shifting is not possible. When the hub doesn't work.
While pedaling.	Shifting lever indicator doesn't match hub shifting position.	
	Turning is stiff.	4.8
		Except 4.8
	Gear Unsmooth	4.8
		Except 4.8
Cone Unsmooth		
While not pedaling.	Free rotation is stiff.	

Following treatment is for 8C

Trouble condition		Remedy
While braking.	Braking is too sudden.	Replace the brake shoe unit, Driver unit & axle unit.
	Braking force is weak.	Replace the brake shoe unit.
	Pedal turning angle for brake to operate is too large.	Replace the brake shoe unit, Driver unit & axle unit.
	Wheels lock when bicycle is pushed backward.	Replace carrier unit, driver unit and clutch unit.
	A squeaking sound caused by lack of lubrication can be heard.	Apply grease or replace the brake shoe unit.
	Brakes do not release.	Replace the brake shoe unit and carrier unit.

Replacement of the internal unit

SG-8C20

Note:

Unit parts should never be disassembled. If they are, problems may result.

When replacing parts, replace the whole internal assembly or whole unit part.



Tools

Note:

Unit parts should never be disassembled. If they are, problems may result.

When replacing parts, replace the whole internal assembly or whole unit part.

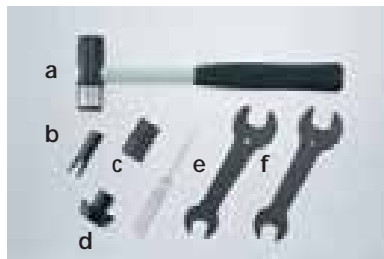

- c: TL-8S20
Right Hand Cone Installation Tool
Part No. Y-708 00200
- d: TL-8S30
Carrier Unit Alignment tool
Part No. Y-708 00300
- e: Screwdriver
- f: TL-7S20
Hub Spanners 17mm x 22mm (2 pcs.)
Part No. 3-130 9890

Note:

For internal unit replacement only tools "e" and "f" are necessary.

- a: Hammer
- b: TL-8S11
Right Hand Cone Removal Tool
Part No. Y-708 00600

(We recommend the use of protective glasses during disassembly and assembly)

1. Hold the two bevelled surfaces of the hub axle on the brake arm side in a vice and remove the dust cap.



Note:
Do not damage the threads of the hub axle.

Vice

2. Turn the hub upside down and hold the two bevelled surfaces of the hub axle on the sprocket side in a vice.



Note:
Do not damage the threads of the hub axle.



Remove the left hand locknut from the hub axle, and then remove the stop nut.

TL-7S20



Locknut 17mm (Y-35P 28000)



Stop Nut 22mm (Y-35P 22000)

3. Remove the brake arm unit and ball retainer B from the hub axle.

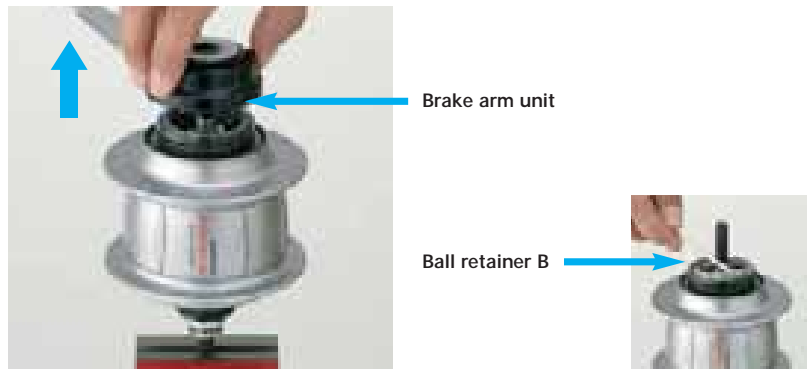

4. Remove the hub shell.



Now it can be replaced with the new internal assembly.

Disassembly and assembly can be carried out quickly.
Part No. 36P 98010



Disassembly of the internal unit

1. Remove the brake shoe unit.



2. Carefully remove the stop ring with a screwdriver. Because the stop ring will tend to come off with some force, use a piece of cloth to prevent loss.



3. Remove carrier unit and ring gear by lifting straight up. Do not rotate to disengage.

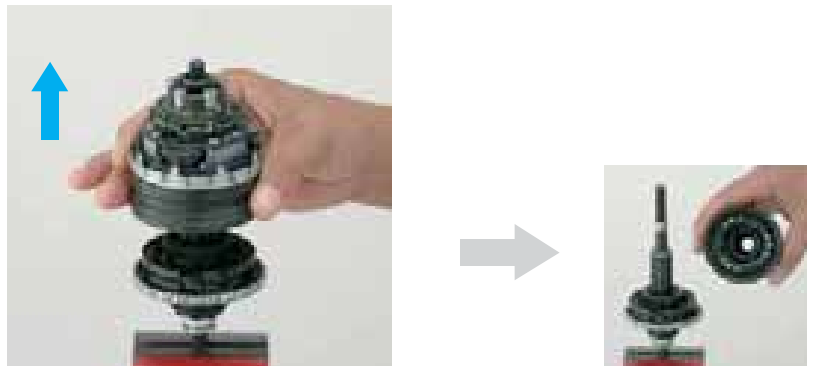

4. Remove the ring gear slide spring with a screwdriver.



5. Remove ball retainer O (3/16"X26) while pushing pawls B.



6. Reverse axle unit in vice to access the drive side cone assembly.



7. Remove the locknut with a 17mm hub spanner.



8. Remove the stop washer.



9. Remove the lock washer.



10. Remove the driver plate.



11. Support the driver assembly on the vice, as shown. Set cone removal tool (TL-8S11) into the groove such that the pawl A is contacting the notch in the tool, see detail. Strike the tool with the hammer until cone and axle unit are separated.

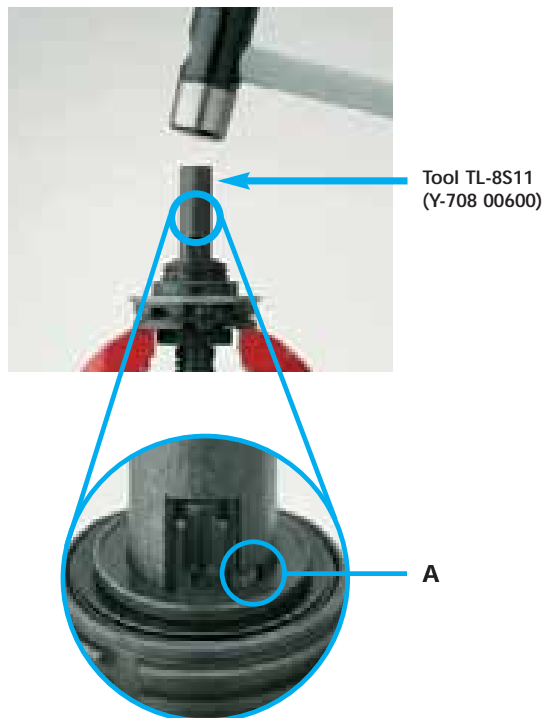

12. Reverse the right hand cone.

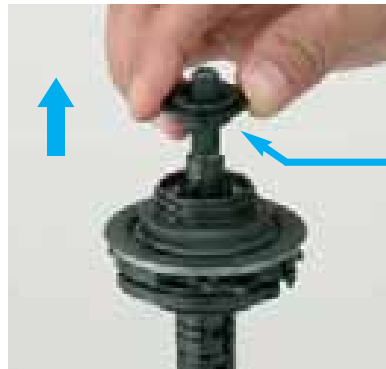

Right hand cone
(Y-34R 98080)

13. Remove the ball retainer P
(3/16"X13).

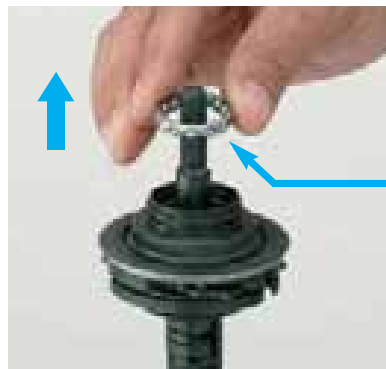

Ball retainer P
(Y-34R 98070)

14. Remove the driver unit.



Driver unit
(Y-35P 98070)

15. Remove the return spring A.



Return spring A
(Y-34R 21000)

16. Remove the clutch unit by turning it counterclockwise and aligning the two teeth to the two grooves, as shown.



This completes the disassembly of the INTER-8 coaster hub.



Assembly of the INTER-8 coaster hub

1. With the hub axle unit mounted in a vice, align the two teeth on the clutch unit with the two notches in the hub axle unit. Turn the clutch unit clockwise until it is in its final position as shown.

Clutch unit
(Y-35P 98060)

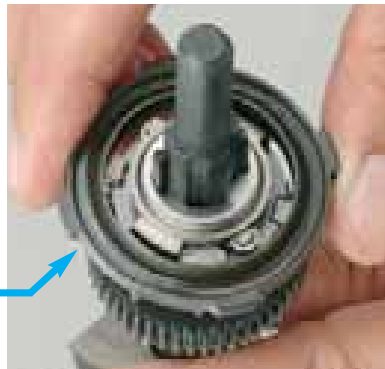

NOTE:

During the assembly procedures coat all seals, gears and pawl assemblies with a thin coat of Nexus specific grease. Where indicated by blue grease icon, apply grease liberally.



(Y-041020800)



2. Install the return spring with the largest coil downward. The spring should sit in the groove on the clutch unit, shown as a blue line in the picture. Be careful not to install the return spring A upside down.



Return spring A
(Y-34R 21000)



3. Assemble the driver unit by aligning the more shallow notch on the driver unit with the wider tooth on the clutch unit. Rotate the driver counterclockwise to hold the compressed spring in position.

Clutch unit
(Y-34R 98050)



NOTE:

Assemble the driver unit while pushing pawls B as shown in the picture.



Set drive unit while turn it counterclockwise.

4. Install the ball retainer P (3/16"X13).



Ball retainer P (Y-34R 98070)



(Y-041020800)

5. When installing the right hand cone, align the two serrations with the grooves in the axle, as shown. Set the cone installation tool (TL-8S20) and strike it until it comes to a stop.



Right hand cone (Y-34R 98080)

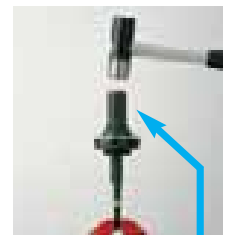

Tool TL-8S20 (Y-708 00200)

NOTE:

Make sure the right hand cone is completely seated, as shown, and the seal is installed equally.



ok



6. Install the driver plate. Be careful of the setting direction as shown in the picture.

Driver plate (Y-34R 12000)



ok



7. Install the lock washer.



Lock washer
 (Y-34R 98090)

8. When installing the stop washer, align the two teeth with the two grooves of the lock washer.



Stop washer
 (Y-34R 09000)



9. Install the right hand locknut with a 17mm hub spanner.

NOTE:

If either the lock washer or driver plate rotates during this step, return to assembly step 5 and make sure that the cone is correctly seated.

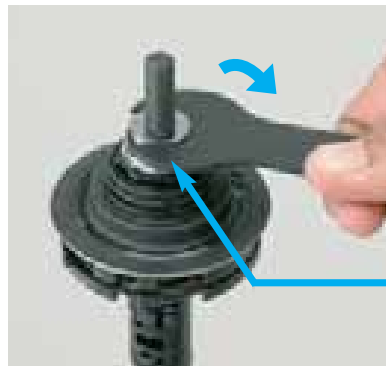

Tightening torque:
 25 - 30 N·m {218 - 261 in.lbs}

Right hand locknut
 (Y-33Z 07020)

10. Reverse the axle unit in the vice to complete assembly.

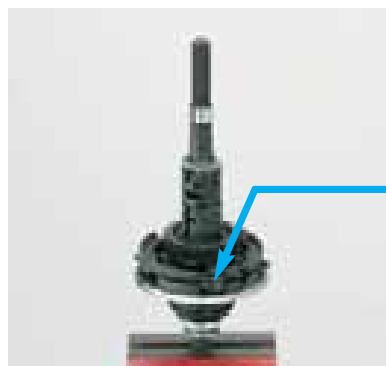

(Y-041020800)

11. Install the ball retainer O (3/16" X 26) while pushing pawls B one by one. Be careful not to displace pawls B on the driver unit.

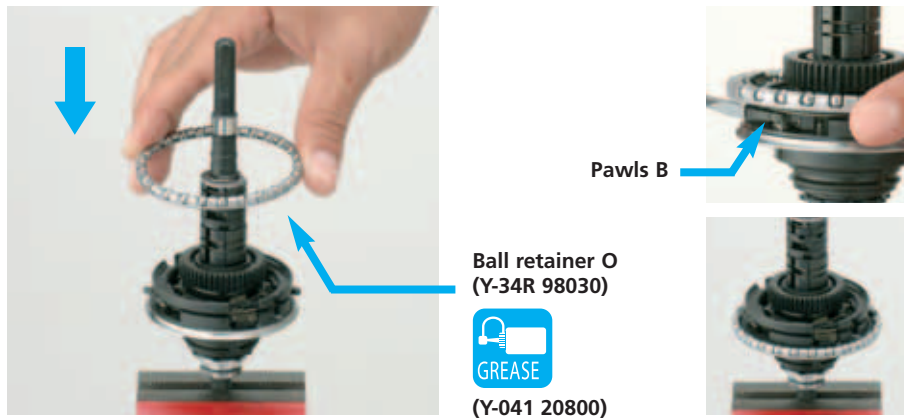

12. How to align the three planetary gears and install the ring gear.

(Without any tools)
Align the three marks, which are on the planetary gears, as shown in the picture.

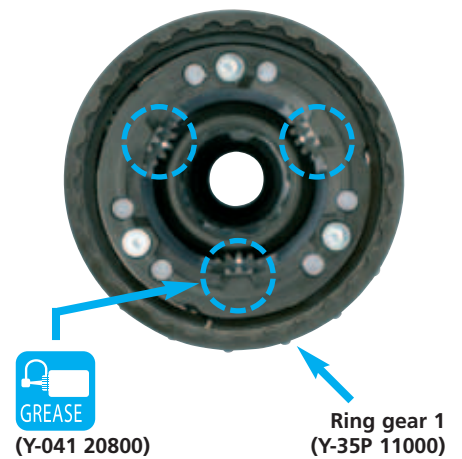
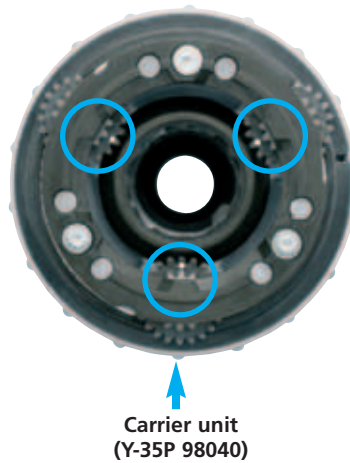

(With tool)
Align the grooves of the tool with the marks on the planetary gears. The purpose of the tool is to fix the planetary gear's position. Now you can install the ring gear.

Tool TL-8530 (Y-708 00300)

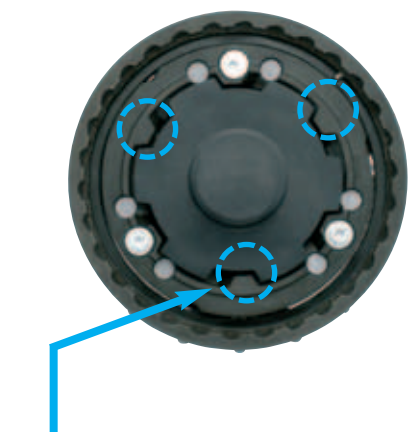

Install the ring gear slide spring with a screwdriver.

Ring gear 1 stop ring (Y-34R 80000)



GREASE (Y-041 20800)

13. Align the internal tooth on the ring gear and carrier unit with the groove in the hub axle unit. Install ring gear and carrier unit slowly.

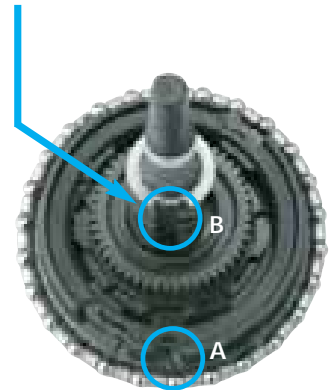

NOTE:

Be careful to fit A to A and B to B of the driver unit and the hub axle unit as shown in the picture.

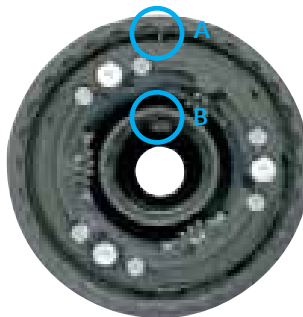

Important:

To set all four pawls in the correct position. Use a flat blade screwdriver to depress pawls, as shown, during assembly. Turn unit and check that all pawls are in the proper position.

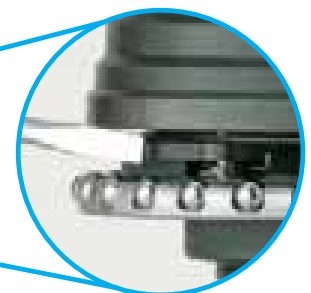

14. Insert the stop ring.

NOTE:

If there is no visible groove to receive the stop ring, it is likely that the ring gear and carrier unit are not properly assembled, return to assembly step 13.



Stop ring
(Y-33Y 19000)



(Y-041020800)

15. Install the brake shoe unit.



Brake shoe unit
(Y-35P 98020)

16. Install the hub shell unit while turning it counter-clockwise.



Hub shell

Internal assembly

17. Place ball retainer B onto the hub shell.

Ball retainer B
(Y-330 98110)



(Y-041020800)



Note:

Be careful of the setting direction.



Apply a liberal coating of internal hub grease.

Hub shell

18. Place the brake arm unit onto the hub axle and turn it to the left and right so that the serrations of the brake shoe and brake arm unit engage with each other. Then push the brake arm unit fully into the brake shoe unit.



Brake arm unit (Y-35P 98080)

Brake shoe unit (Y-35 98020)

Serrations

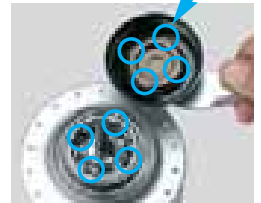

Note:

Apply a liberal coating of internal hub grease to the inside and outside of the brake shoe unit.

19. Screw the stop nut to adjust so that the hub shell can be turned smoothly without any play. After adjusting, secure the stop nut with the locknut.



TL-7S20



Locknut 17mm (Y-35P 28000)



Stop nut 22mm (Y-35P 22000)

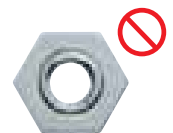

(Back side)

20. Install the dust cap.



(Y-041020800)

This completes the assembly of the INTER-8 coaster hub.



Cassette Joint

CJ-8S20 for 8 speed



CJ-8S40 for 8 speed



Measurement Tool

TL-CJ10 for CJ-8S20

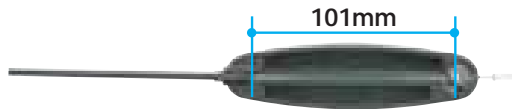

TL-CJ40 for CJ-8S20

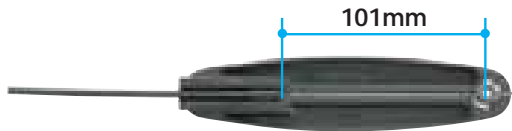

TL-CJ40 for CJ-8S40

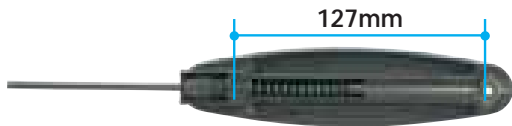



SG-8R20



SG-8R25
SG-8R45

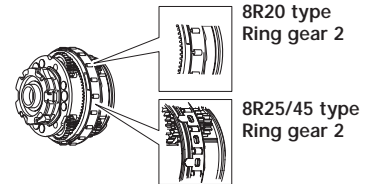

CHAIN DRIVE			Hub Shell + Internal Unit		
			SG-8R20	SG-8R25	SG-8R45
Internal Unit 	SG-8R20 standard	Mass production & replacement	YES	Possible not recommended	NO
	SG-8R25 Premium	Mass production	NO	YES	NO
		Replacement (8R20 type Ring gear 2)	YES ^{*1}	YES	NO
	SG-8R45 for CYBER NEXUS	Mass production	NO	NO	YES
		(8R20 type Ring gear 2)	NO	NO	YES







* = possible, but not the same performance as original spec.

BELT DRIVE			Hub Shell + Internal Unit		
			SG-8R20	SG-8R25	SG-8R45
Internal Unit 	SG-8R20 standard	Mass production & replacement	YES	Possible not recommended	NO
	SG-8R25 Premium	Mass production	NO	YES	NO
		Replacement (8R20 type Ring gear 2)	YES ^{*1}	YES	NO
	SG-8R45 for CYBER NEXUS	Mass production	NO	NO	YES
		(8R20 type Ring gear 2)	NO	NO	YES



* = possible, but not the same performance as original spec.

CHAIN DRIVE			Hub Shell + Internal Unit	
			SG-8C20	SG-8C45
Internal Unit 	SG-8C20 standard	Mass production & replacement	YES	NO
	SG-8C45 for CYBER NEXUS	Mass production & replacement	NO	YES

NEXUS non-turn washers

	For right hand side	For left hand side
5R/L	 5R:Yellow	 5L:Brown
6R/L	 6R:Silver	 6L:White
7R/L	 7R:Black	 7L:Gray

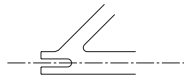
NEXUS non-turn washer application chart

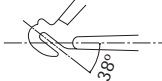
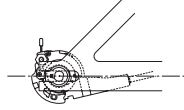
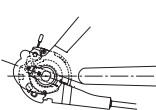
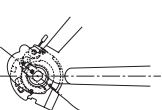
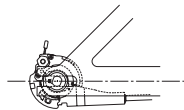
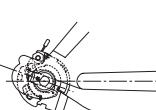
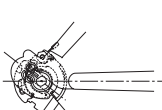
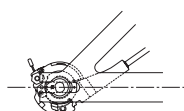
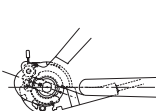
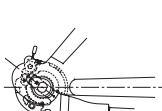
	Reversed fork end	Standard fork end	
		 20°	 38°
5R/L	 Good	 Good	 NR
6R/L	 Good	 NR	 NR
7R/L	 NR	 Good	 Good

NR: not recommend

Hub dimensions (Over Locknut Dimension and Axle)

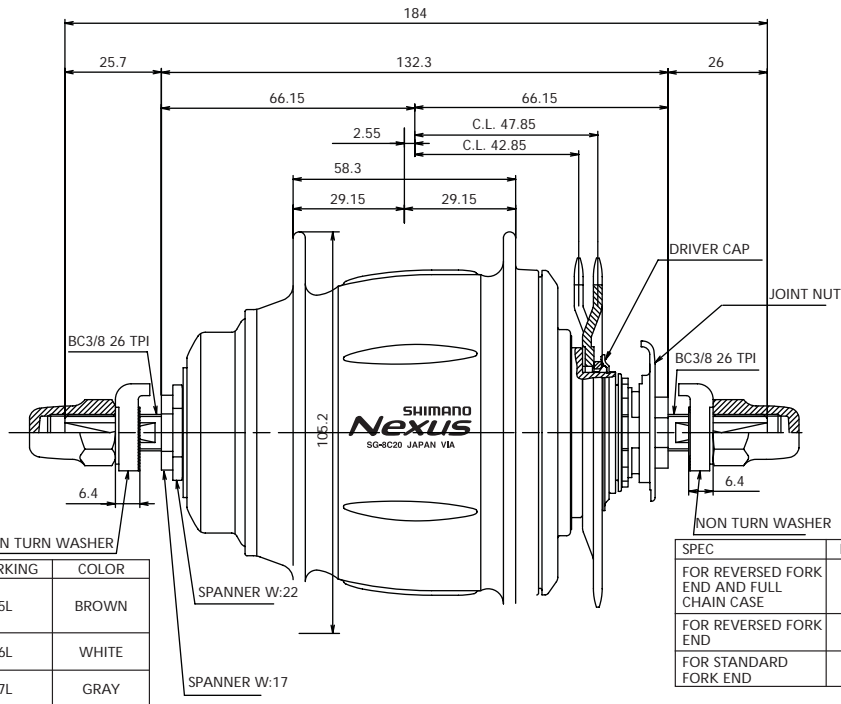

SPEC	MARKING	COLOR
FOR REVERSED FORK END AND FULL CHAIN CASE	5L	BROWN
FOR REVERSED FORK END	6L	WHITE
FOR STANDARD FORK END	7L	GRAY

SPEC	MARKING	COLOR
FOR REVERSED FORK END AND FULL CHAIN CASE	5R	YELLOW
FOR REVERSED FORK END	6R	SILVER
FOR STANDARD FORK END	7R	BLACK

SPEC	øX	øY	SURFACE TREATMENT OF HUB SHELL
STANDARD (BOTH USE FOR #13, #14)	2.9	3.9	SILVER PAINTING

Specifications

Function Name	INTER-8 coaster	
Speed	8	
Model No.	SG-8C20	
Silent Clutch	X	
Gear Change Support Mechanism	X	
Shifting Power Modulator	X	
Driving Efficiency	Standard	
Brake	Coaster	
Over Locknut Dim. / OLD (mm)	132.3	
Axle Length (mm)	184	
Gear Ratio	Total	307%
	1	0.527
	2	0.644
	3	0.748
	4	0.851
	5	1
	6	1.223
	7	1.419
8	1.615	
Hub Shell Material	Aluminum	
Finish	Painted	
Weight	1,990g	
Spoke Hole	36H	
Spoke Size	#13 / #14	
Flange Dist. (mm)	58.3	
Spoke Hole P.C.D (mm)	92.6	
Flange Diameter (mm)	105.2	
Flange Width (mm)	3.2	
Sprocket Teeth	16T,18T,19T,20T,21T,22T,23T	
Sprocket Thickness (mm)	2.3	
Chain	1/2" X1/8" or 1/2" X3/32"	
Chain Recommend	CN-NX10	
Chain Line (mm) 16-23T	42.85 / 47.85	
Dishing Distance (mm)	2.55	
Shifting Lever / AI	SB-8S20 / ST-8S20 / SL-8S20	
Cassette Joint / Motor Uni	CJ-8S20 / CJ-8S40	

X = available

SHIMANO NEXUS INTER-8 Coaster Hub SG-8C20

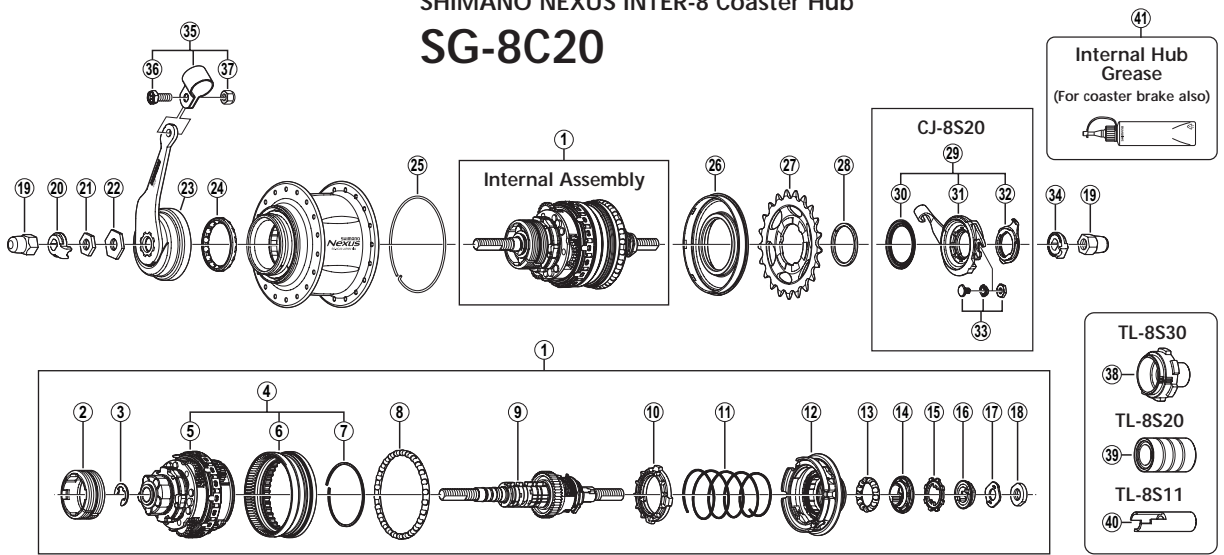

ITEM NO.	SHIMANO CODE NO.	DESCRIPTION
1	Y-35P 98010	Internal Assembly (Axle Length 184 mm)
2	Y-35P 98020	Brake Shoe Unit
3	Y-33Y 19000	Stop Ring (ø 9.6 mm)
4	Y-35P 98030	Ring Gear Unit
5	Y-35P 98040	Carrier Unit
6	Y-35P 11000	Ring Gear 1
7	Y-35P 12000	Ring Gear Slide Spring
8	Y-34R 98030	Ball Retainer O (3/16" x 26)
9	Y-35P 98050	Hub Axle Unit (Axle Length 184 mm)
10	Y-35P 98060	Clutch Unit
11	Y-34R 21000	Return Spring A
12	Y-35P 98070	Driver Unit
13	Y-34R 98070	Ball Retainer P (3/16" x 13)
14	Y-34R 98080	Right Hand Cone w/Seal
15	Y-34R 12000	Driver Plate
16	Y-34R 98090	Lock Washer
17	Y-34R 09000	Stop Washer
18	Y-33Z 07020	Right Hand Lock Nut (3.4 mm)
19	Y-314 14010	Cap Nut (3/8")
20	Y-33M39510	Non-turn Washer 5L (Brown)
	Y-33M39610	Non-turn Washer 6L (White)
	Y-33M39710	Non-turn Washer 7L (Gray)
21	Y-35P 28000	Left Hand Lock Nut (3 mm)
22	Y-35P 22000	Stop Nut
23	Y-35P 98080	Brake Arm Unit
24	Y-330 98110	Ball Retainer B (3/16" x 16)
25	Y-35J 11100	Hub Shell Slide Spring
26	Y-34R 98110	Right Hand Dust Cap A w/Seal
27	Y-322 03220	Sprocket Wheel 16T (Silver)
	Y-322 03420	Sprocket Wheel 18T (Silver)
	Y-322 03520	Sprocket Wheel 19T (Silver)
	Y-322 03620	Sprocket Wheel 20T (Silver)
	Y-330 60000	Sprocket Wheel 21T (Silver)
	Y-330 60100	Sprocket Wheel 22T (Silver)
28	Y-321 20100	Snap Ring C
29	Y-74Y 98120	CJ-8S20 Cassette Joint Unit
30	Y-74Y 18000	Driver Cap
31	Y-74Y 98130	CJ-8S20 Cassette Joint
32	Y-33Z 98020	Cassette Joint Fixing Ring
33	Y-74Y 98030	Inner Cable Fixing Bolt Unit
34	Y-33Z 20500	Non-turn Washer 5R (Yellow)
	Y-33M39600	Non-turn Washer 6R (Silver)
	Y-33M39700	Non-turn Washer 7R (Black)
35	Y-33F 98090	Brake Arm Clip Unit (5/8")
	Y-33F 98100	Brake Arm Clip Unit (3/4")
36	Y-75M06000	Clip Screw (M6 x 16)
37	Y-317 27200	Clip Nut
38	Y-708 00300	TL-8S30 Carrier Unit Tool
39	Y-708 00200	TL-8S20 Right Hand Cone Installation Tool
40	Y-708 00600	TL-8S11 Right Hand Cone Removal Tool
41	Y-041020800	Internal Hub Grease (Net. 100g)

SHIMANO NEXUS 8-speed Revo-Shift Lever

SL-8S20

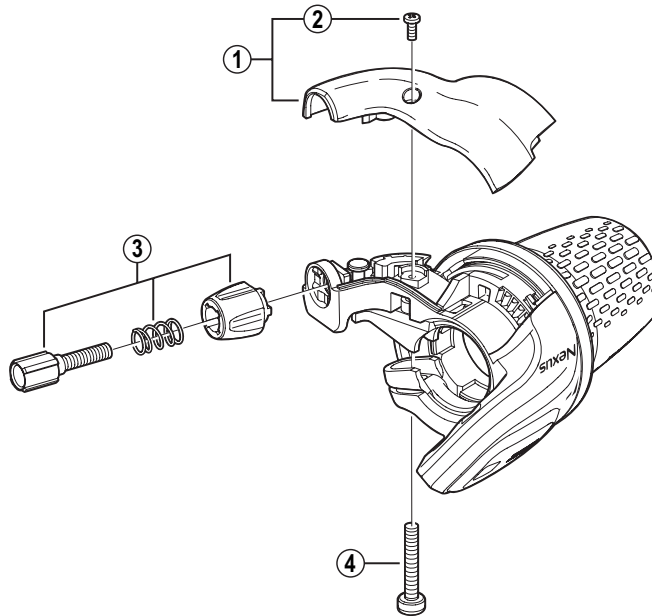

ITEM NO.	SHIMANO CODE NO.	DESCRIPTION
1	Y-6FD 98010	Bracket Cover & Fixing Screw
2	Y-6F0 04000	Cover Fixing Screw
3	Y-61W98030	Cable Adjusting Bolt Unit
4	Y-6F4 09000	Clamp Screw (M4 x 23.5)

Spare parts list

SHIMANO NEXUS Cassette Joint CJ-8S40

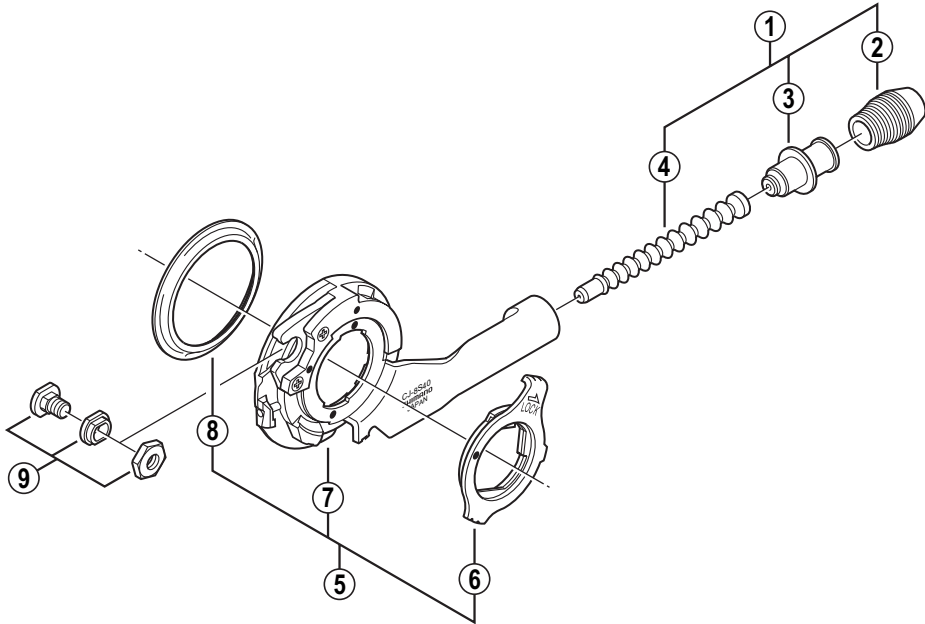

Q'TY	ITEM NO.	SHIMANO CODE NO.	DESCRIPTION
	1	Y-74Y 98160	Outer Casing Holder Unit
	2	Y-74Y 27000	Rubber Cover
	3	Y-74Y 28000	Outer Casing Holder
	4	Y-74Y 30200	Rubber Bellows
	5	Y-74Y 98140	Cassette Joint Unit
	6	Y-33Z 98020	Cassette Joint Fixing Ring
	7	Y-74Y 98150	Cassette Joint
	8	Y-74Y 18000	Driver Cap
	9	Y-74Y 98030	Inner Cable Fixing Bolt Unit

SHIMANO NEXUS Brake Lever

BL-IM65 For Left Hand / 3-Finger

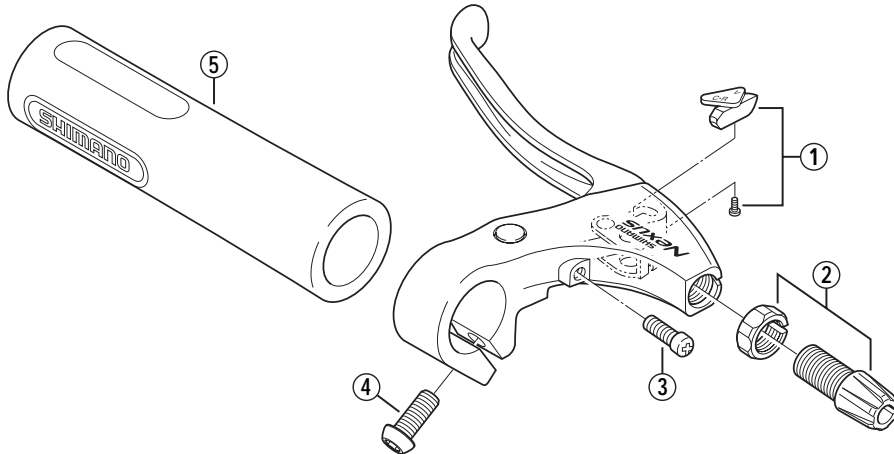

Q'TY	ITEM NO.	SHIMANO CODE NO.	DESCRIPTION
	1	Y-8TS 98020	L.H. Adjustment Block & Screw
	2	Y-6JB 98040	Cable Adjusting Bolt (M10 x 19) & Nut
	3	Y-89E 05010	Reach Adjusting Screw (M4 x 10.8)
	4	Y-8SB 10000	Clamp Bolt (M6 x 14.8)
	5	Y-89M08010	Grip (ø22.2 mm / Black)

BJARNE EGEDESØ A/S

Denmark, Iceland and Greenland
Phone +45 63 16 8001
Fax +45 63 16 8004

BJARNE EGEDESØ BALTICS

Estonia, Latvia and Lithuania
Phone +371 7 29 3688
Fax +371 7 31 2042

COOLHEAT, S.A. LTD.

South Africa
Phone +27 11 807 5282
Fax +27 11 807 2998

EBSAT LASTIK VE YEDEK PARCA TIC. LTD. STI.

Turkey
Phone +90 232 483 13 87
Fax +90 232 483 46 63

EUROTRADE LTD.

Balkans region (incl. Romania and Moldavia)
Phone +30 2610 911450, 911451, 911452
Fax +30 2610 911453

ALBIMI N.T.P.

Kosovo
Phone +381 280 20305
Fax +381 280 28540

CS-EUROTRADE d.o.o.

Slovenia and Croatia
Phone +386 7 49 02 500
Fax +386 7 49 02 549

PLANET BIKE D.O.O.

Serbia & Montenegro, Bosnia & Herzegovina,
Macedonia
Phone +381 11 3149 033
Fax +381 11 3149 101

ROMVELO S.R.L.

Romania
Phone +40 723 550 003
Fax +40 723 550 020

VELOMANIA LTD.

Bulgaria
Phone +3592 812 7060
Fax +3592 812 7061

FUCHS-MOVESA AG

Switzerland
Phone +41 56 464 46 46
Fax +41 56 464 46 47

HALLMAN SPORTS AB

Sweden
Phone +46 18 561 600
Fax +46 18 500 395

HALLMAN SPORTS AS

Norway
Phone +47 66778010
Fax +47 66778011

HALLMAN SPORTS OY

Finland
Phone +358 20 1550 800
Fax +358 20 1550 801

MACARIO LLORENTE, S.A.

Spain
Phone +34 91 329 5070
Fax +34 91 329 2594 / 91 329 2039

MADISON CYCLES PLC

UK and Ireland
Phone +44 208 385 3385
Fax +44 208 385 3443

M.I.C. MILAN INTERNATIONAL COMMERCE SpA

Italy, Malta and Tunisia
Phone +39 331 467 311
Fax +39 331 464 790

NIKOS MANIATOPOULOS S.A.

Greece and Cyprus
Phone +30 2610 993 045
Fax +30 2610 990 424

PAUL LANGE & CO.

Germany
Phone +49 711 2588 02
Fax +49 711 2588 305

PAUL LANGE OSTRAVA S.R.O.

Czech Republic
Phone +420 597 444 160
Fax +042 597 444 150

PAUL LANGE OSLANY S.R.O.

Slovak Republic
Phone +42 46 549 2344
Fax +42 46 549 2350

R & P PAWLAK

Poland
Phone +48 61 878 7335
Fax +48 61 878 7266

SABA DOCHARKH (CYCLE) CO. LTD.

Iran
Phone +98 21 878 0651-2
Fax +98 21 878 7278

SHIMANO BENELUX B.V.

The Netherlands, Belgium and Luxembourg
Phone +31 341 272 327
Fax +31 341 272 291

OOO SHIMANO EURASIA

Russia and Belarus
Phone/Fax +7 095 101 34 88

SHIMANO FRANCE COMPOSANTS CYCLES

France
Phone +33 321 73 2525
Fax +33 321 55 8427

SOC. COMERCIAL DO VOUGA LDA.

Portugal
Phone +351 234 601 500
Fax +351 234 601 159

THALINGER-LANGE GMBH

Austria
Phone +43 7242 4970
Fax +43 7242 4972 48

VELOTRADE KFT.

Hungary
Phone +36 1 455 8000
Fax +36 1 455 8019