
TECHNICAL MANUAL

**PAINTING AND MARKING
OF ARMY AIRCRAFT**

This copy is a reprint which includes current
pages from Changes 1 through 4

This publication supersedes TB 746-93-2 10 August 1978, including all changes

HEADQUARTERS DEPARTMENT OF THE ARMY

12 JUNE 1986

CHANGE

NO. 8

HEADQUARTERS
DEPARTMENT OF THE ARMY
WASHINGTON, DC 30 December 1998

**PAINTING AND MARKING
OF ARMY AIRCRAFT**

DISTRIBUTION STATEMENT A: Approved for public release; distribution is unlimited.

TM 55-1500-345-23, 12 June 1986, is changed as follows:

1. Remove and insert pages as indicated below. New or changed text material is indicated by a vertical bar in the margin. An illustration change is indicated by a miniature pointing hand.

Remove Pages

a/(b blank)
i and ii
2-1 and 2-2
2-5 through 2-8
3-15 through 3-18
3-29/(3-30 blank)
4-3 and 4-4
6-1 and 6-2
6-13 and 6-14
6-17 and 6-18
8-5 through 8-8
9-7 and 9-8
9-111 and 9-112
9-123 and 9-124
9-161 through 9-176

Insert Pages

a/(b blank)
i and ii
2-1 and 2-2
2-5 through 2-8
3-15 through 3-18
3-29/(3-30 blank)
4-3 and 4-4
6-1 and 6-2
6-13 and 6-14
6-17 and 6-18
8-5 through 8-8
9-7 and 9-8
9-111 and 9-112
9-123 and 9-124
9-161 through 9-176
9-176.1/(9-176.2 blank)

2. Retain this sheet in front of manual for reference purposes.

By Order of the Secretary of the Army:

By Order Of the Secretary of the Army:

Official:



Handwritten signature of Joel B. Hudson in black ink.

JOEL B. HUDSON

*Administrative Assistant to the
Secretary of the Army*

05283

DENNIS J. REIMER
General, United States Army
Chief of Staff

DISTRIBUTION: To be distributed in accordance with Initial Distribution No. (IDN) 311338, requirements for TM 55-1500-345-23.

CHANGE
NO.7

HEADQUARTERS,
DEPARTMENT OF THE ARMY
WASHINGTON, D.C., 20 September 1996

**PAINTING AND MARKING
OF ARMY AIRCRAFT**

DISTRIBUTION STATEMENT A: Approved for public release; distribution is unlimited.

TM 55150034523, 12 June 1986, is changed as follows:

1. Remove and insert pages as indicated below. New or changed text material is indicated by a vertical bar in the margin. An illustration change is indicated by a miniature pointing hand.

Remove pages

i and ii
1-1 and 1-2
2-1 and 2-2
3-3 and 3-4

8-1 and 8-2
9-21 and 9-22
9-29 and 9-30

9-31 and 9-32
9-32.1/(9-32.2 blank)
9-115 and 9-116
9-119 and 9-120
9-163 and 9-164
9-185 through 9-192
9-197 through 9-200.2

Insert pages

i and ii
1-1 and 1-2
2-1 and 2-2
3-3 and 3-4
3-29/(3-30 blank)
8-1 and 8-2
9-21 and 9-22
9-29 and 9-30
9-30.1/(9-30.2 blank)
9-31 and 9-32

9-115 and 9-116
9-119 and 9-120
9-163 and 9-164
9-185 through 9-192
9-197 through 9-200.2

2. Retain this sheet in front of manual for reference purposes.

TM 55-1500-345-23
C7

By Order of the Secretary of the Army:

Official:

DENNIS J. REIMER
General, United States Army
Chief of Staff

JOELB.HUDSON
Administrative Assistant to the
Secretary of the Army
02988

DISTRIBUTION:

To be distributed in accordance with DA Form 1231E, block no. 1338, requirements for TM 551500-345-23.

CHANGE

NO. 6

HEADQUARTERS,
DEPARTMENTS OF THE ARMY
WASHINGTON, D.C., 28 February 1995

**PAINTING AND MARKING
OF ARMY AIRCRAFT**

DISTRIBUTION STATEMENT A: Approved for public release; distribution is unlimited

TM 55-1500-345-23, 12 June 1986, is changed as follows:

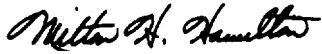
1. Remove and insert pages as indicated below. New or changed text material is indicated by a vertical bar in the margin. An illustration change is indicated by a miniature pointing hand.

Remove pages	Insert pages
i and ii	i and ii
3-3 and 3-4	3-3 and 3-4
3-17 and 3-18	3-17 and 3-18
6-3 and 6-4	6-3 and 6-4
6-13 and 6-14	6-13 and 6-14
8-7 and 8-8	8-7 and 8-8
9-3 and 9-4	9-3 and 9-4
9-9 and 9-10	9-9 and 9-10
9-13 through 9-30	9-13 through 9-30
-----	9-30.1/(9-30.2 blank)
9-31 and 9-32	9-31 and 9-32
9-191 and 9-192	9-191 and 9-192
9-189 and 9-200	9-199 and 9-200

2. Retain this sheet in front of manual for reference purposes.

By Order of the Secretary of the Army:

Official:



MILTON H. HAMILTON
*Administrative Assistant to the
Secretary of the Army*

GORDON R. SULLIVAN
*General, United States Army
Chief of Staff*

DISTRIBUTION:

To be distributed in accordance with DA Form 12-25-E, block no. 1338, requirements for TM 55-1500-345-23.

CHANGE
NO. 5

HEADQUARTERS
DEPARTMENT OF THE ARMY
WASHINGTON, D.C., 4 April 1994

PAINTING AND MARKING
OF ARMY AIRCRAFT

DISTRIBUTION STATEMENT A: Approved for public release; distribution is unlimited.

TM 55-1500-345-23,12 June 1986, is changed as follows

1. Remove and insert pages as indicated below. New or changed text material is indicated by a vertical bar in the margin. An illustration change is indicated by a miniature pointing hand.

Remove pages

i and ii
ix and x
1-1 and 1-2
6-17 and 6-18
7-11 and 7-12
7-19 and 7-20

9-1 through 9-12
9-15 and 9-16
9-27 and 9-28
9-31 and 9-32
9-67 and 9-68
9-71 through 9-80
9-103 through 9-106
9-111 through 9-124
9-137 through 9-142
9-157 through 9-164
9-167 through 9-176
9-181 through 9-200

10-23 and 10-24
10-49 and 10-50
10-61 and 10-62
10-65 and 10-66
10-87 and 10-88
10-111 and 10-112

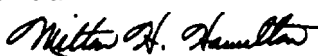
Insert pages

i and ii
ix and x
1-1 and 1-2
6-17 and 6-18
7-11 and 7-12
7-19 and 7-20
7-29/(7-30 blank)
9-1 through 9-12
9-15 and 9-16
9-27 and 9-28
9-31 and 9-32
9-67 and 9-68
9-71 through 9-80
9-103 through 9-106
9-111 through 9-124
9-137 through 9-142
9-157 through 9-164
9-167 through 9-176
9-181 through 9-200
9-200.1 and 9-200.2
10-23 and 10-24
10-49 and 10-50
10-61 and 10-62
10-65 and 10-66
10-87 and 10-88
10-111 and 10-112

2. Retain this sheet in front of manual for reference purposes.

By Order of the Secretary of the Army:

Official:


MILTON H. HAMILTON
Administrative Assistant to the
Secretary of the Army
06573

GORDON R. SULLIVAN
General, United States Army
Chief of Staff

DISTRIBUTION:

To be distributed in accordance with DA Form 12-25-E, block no. 1338, requirements for
TM 55-1500-345-23.

CHANGE

NO. 4

HEADQUARTERS
DEPARTMENT OF THE ARMY
WASHINGTON, D.C., 28 February 1991

PAINTING AND MARKING
OF ARMY AIRCRAFT

TM 55-1500-345-23, 12 June 1986, is changed as follows:

1. Remove and insert pages as indicated below. New or changed text material is indicated by a vertical bar in the margin. An illustration change is indicated by a miniature pointing hand.

Remove pages

i through iv
2-1 through 2-8
3-1 through 3-4
5-3 and 5-4
6-1 and 6-2
6-7 through 6-10
6-13 and 6-14
6-14.1/6-14.2
6-15 and 6-16
7-9 and 7-10
8-1 and 8-2
9-111 and 9-112
9-115 and 9-116
9-121 through 9-124
9-131 through 9-134
9-159 and 9-160
9-167 and 9-168
9-171 and 9-172
9-177 through 9-180
2028's and Envelopes

Insert pages

i through iv
2-1 through 2-8
3-1 through 3-4
5-3 and 5-4
6-1 and 6-2
6-7 through 6-10
6-13 and 6-14
6-14.1 and 6-14.2
6-15 and 6-16
7-9 and 7-10
8-1 and 8-2
9-111 and 9-112
9-115 and 9-116
9-121 through 9-124
9-131 through 9-134
9-159 and 9-160
9-167 and 9-168
9-171 and 9-172
9-177 through 9-180
2028's and Envelopes

2. Retain this sheet in front of manual for reference purposes.

By Order of the Secretary of the Army:

Official:

THOMAS F. SIKORA
Brigadier General, United States Army
The Adjutant General

CARL E. VUONO
General, United States Army
Chief of Staff

DISTRIBUTION:

To be distributed in accordance with DA Form 12-31-E, block no. 1338, AVUM and AVIM maintenance requirements for TM 55-1500-345-23.

Change }
NO. 3 }

HEADQUARTERS
DEPARTMENT OF THE ARMY
WASHINGTON, D.C., 09 November 1989

PAINTING AND MARKING
OF ARMY AIRCRAFT

TM 55-1500-345-23, 12 June 1986 is changed as follows:

1. Remove and insert pages as indicated below. New or changed text material is indicated by a vertical bar in the margin. An illustration change is indicated by a miniature pointing hand.

Remove pages	Insert pages
7-7 and 7-8	7-7 and 7-8
7-15 through 7-20	7-15 through 7-20
7-27 and 7-28	7-27/7-28
8-7 and 8-8	8-7 and 8-8
9-171 and 9-172	9-171 and 9-172

2. Retain this sheet in front of manual for reference purposes.

By Order of the Secretary of the Army:

CARL E. VUONO
General, United States Army
Chief of Staff

Official:

WILLIAM J. MEEHAN II
Brigadier General, United States Army
The Adjutant General

DISTRIBUTION:

To be distributed in accordance with DA Form 12-31, AVUM and AVIM Maintenance requirements for All Fixed and Rotary Wing Aircraft.

Change }
NO. 2 }

HEADQUARTERS
DEPARTMENT OF THE ARMY
WASHINGTON, D.C., 14 August 1989

PAINTING AND MARKING
OF ARMY AIRCRAFT

TM 55-1500-345-23, 12 June 1986 is changed as follows:

1. Remove and insert pages as indicated below. New or changed text material is indicated by a vertical bar in the margin. An illustration change is indicated by a miniature pointing hand.

Remove pages	Insert pages
1-1 and 1-2	1-1 and 1-2
2-3 and 2-4	2-3 and 2-4
5-1 and 5-2	5-1 and 5-2
6-13 and 6-14	6-13 and 6-14
- - -	6-14.1/6-14.2
6-19 and 6-20	6-19 and 6-20
7-1 and 7-2	7-1 and 7-2
8-1 and 8-2	8-1 and 8-2
8-3 and 8-4	8-3 and 8-4
9-129 and 9-130	9-129 and 9-130
9-161 through 9-164	9-161 through 9-164
9-171 and 9-172	9-171 and 9-172
9-193 and 9-194	9-193 and 9-194

2. Retain this sheet in front of manual for reference purposes.

By Order of the Secretary of the Army:

CARL E. VUONO
General, United States Army
Chief of Staff

Official:

WILLIAMJ.MEEHAN II
Brigadier General, United States Army
The Adjutant General

DISTRIBUTION:

To be distributed in accordance with DA Form 12-31, AVUM and AVIM Maintenance requirements for All Fixed and Rotary Wing Aircraft.

CHANGE

NO. 1

HEADQUARTERS
DEPARTMENT OF THE ARMY
WASHINGTON, D.C., 1 July 1988

PAINTING AND MARKING
OF ARMY AIRCRAFT

TM 55-1500-345-23, 12 June 1986 is changed as follows:

1. Remove and insert pages as indicated below. New or changed text material is indicated by a vertical bar in the margin. An illustration change is indicated by a miniature pointing hand.

Remove pages	Insert pages
a/b	a/b
i and ii	i and ii
v through x	v through x
xi/xii	xi/xii
1-1 and 1-2	1-1 and 1-2
1-3/1-4	1-3/1-4
2-7 and 2-8	2-7 and 2-8
3-1 through 3-4	3-1 through 3-4
- - -	3-4.1/3-4.2
3-5 through 3-8	3-5 through 3-8
3-13 through 3-16	3-13 through 3-16
4-1 and 4-2	4-1 and 4-2
5-3 and 5-4	5-3 and 5-4
6-1 and 6-2	6-1 and 6-2
6-13 through 6-16	6-13 through 6-16
6-19 through 6-22	6-19 through 6-22
- - -	6-22.1/6-22.2
7-1 through 7-4	7-1 through 7-4
7-7 through 7-28	7-7 through 7-28
8-5 through 8-8	8-5 through 8-8
- - -	8-8.1/8-8.2
8-23 and 8-24	8-23 and 8-24
- - -	8-24.1/8-24.2
8-25 and 8-26	8-25 and 8-26
9-1 through 9-8	9-1 through 9-8
9-11 through 9-14	9-11 through 9-14
9-25 and 9-26	9-25 and 9-26
9-33 and 9-34	9-33 and 9-34
9-67 and 9-68	9-67 and 9-68
9-85 and 9-86	9-85 and 9-86

Remove pages

9-101 and 9-102
9-109 through 9-112
9-115 through 9-122
9-127 through 9-148
9-153 through 9-172
9-175 through 9-180
9-185 and 9-186
9-195 and 9-196
10-23 and 10-24
10-39 and 10-40
10-83 and 10-84
10-111 and 10-112

Insert pages

9-101 and 9-102
9-109 through 9-112
9-115 through 9-122
9-127 through 9-148
9-153 through 9-172
9-175 through 9-180
9-185 and 9-186
9-195 and 9-196
10-23 and 10-24
10-39 and 10-40
10-83 and 10-84
10-111 and 10-112

2. Retain these sheets in front of manual for reference purposes.

By Order of the Secretary of the Army:

Official:

WILLIAM J. MEEHAN II
Brigadier General, United States Army
The Adjutant General

CARL E. VUONO
General, United States Army
Chief of Staff

DISTRIBUTION:

To be distributed in accordance with DA Form 12-31-R, AVUM and AVIM requirements for All Fixed and Rotary Wing Aircraft.

WARNING**PRECAUTIONARY DATA**

Personnel performing instructions involving operations, procedures, and practices which are included or implied in this technical manual shall observe the following instructions. Disregard of these warnings and precautionary information can cause serious injury, death, or an aborted mission.

USING SOLVENT/PAINTS

Standard precautions such as fire prevention and adequate ventilation shall be exercised when using solvents or applying primer and coating.

ELECTRICAL WIRING

Disconnect all electrical wiring before removing any part of aircraft.

WARNING

An operating procedure, practice, etc., which, if not correctly followed, could result in personnel injury or loss of life.

CAUTION

An operating procedure, practice, etc., which, if not strictly observed, could result in damage to or destruction of equipment.

NOTE

An operating procedure, condition etc., which it is essential to highlight.

WARNING

This document has been reviewed for the presence of Class I Ozone Depleting Chemicals (ODCs) as defined by the U.S. Environmental Protection Agency (EPA) as of 1 January, 1996. All references to Class I ODCs have been removed from this technical manual.

PAINTING AND MARKING OF ARMY AIRCRAFT

REPORTING ERRORS AND RECOMMENDING IMPROVEMENTS

You can help improve this manual. If you find any mistakes, or if you know of a way to improve these procedures, please let us know. Mail your letter or DA Form 2028 (Recommended Changes to Publications and Blank Forms), or DA Form 2028-2 located in the back of this manual directly to: Commander, US Army Aviation and Missile Command, ATTN: AMSAM-MMC-LS-LP, Redstone Arsenal, AI 35898-5230. You may also submit your recommended changes by E-mail directly to ls-lp@redstone.army or by fax 256-842-6546/DSN 788-6546. A reply will be furnished directly to you. Instructions for sending an electronic 2028 may be found at the back of this manual immediately preceding the hard copy 2028.

TABLE OF CONTENTS

	<u>Paragraph</u>	<u>Page</u>
CHAPTER 1. GENERAL		
Section I. Purpose And Scope		
Purpose	1-1	1-1
Scope	1-2	1-1
Restrictions	1-3	1-1
Deviations	1-4	1-1
Section II. Responsibilities		
Organizational Activities	1-5	1-1
Depot Activities	1-6	1-2
International Standardization	1-7	1-2
Section III. Authorized Paint Schemes		
General	1-8	1-2
Tactical Aircraft Painting	1-9	1-2
Exceptions to Tactical Aircraft Painting	1-10	1-3
CHAPTER 2. SURFACE PREPARATION		
Section I. Cleaning		
General	2-1	2-1
Section II. Stripping		
General	2-2	2-1
Methods	2-3	2-2
Surfaces not to be Stripped	2-4	2-2
Protection of Surfaces not to be Stripped	2-5	2-3
General Preparations	2-6	2-3

Change 1 superseded TM 55-6600-200-20

TABLE OF CONTENTS - Continued

	<u>Paragraph</u>	<u>Page</u>
Application of MIL-R-81294 & MIL-R-25134 Paint Removers.	2-7	2-4
Stripping in Confined Locations.....	2-8	2-5
Mechanical Removal from Metals	2-9	2-5
Special Conditions.....	2-10	2-7
Section III. Metal Conditioning		
Metal Treatment	2-11	2-7
Chemical Coatings (Conversion Coatings)	2-12	2-7
Pretreatment and Sealing of Bare Metal Surfaces.....	2-13	2-8
CHAPTER 3		
PAINTING - GENERAL		
Section I. Painting Techniques		
Storage of Painting Materials	3-1	3-1
Safety and Health Aspects of Painting.....	3-2	3-2
Atmospheric Conditions for Painting	3-3	3-3
Surface Condition.....	3-4	3-4
Mating Surfaces	3-5	3-4.1
Masking	3-6	3-5
Mixing.....	3-7	3-6
Thinning.....	3-8	3-7
Application Equipment.....	3-9	3-7
Painting Difficulties and Remedies.....	3-11	3-11
Film Thickness (Aircraft Surfaces)	3-12	3-12
Section II. Primers		
General.....	3-13	3-14
Primers.....	3-14	3-15
Section III. Finish Painting: General		
MIL-C-46168	3-15	3-16
MIL-C-83286, Gloss Urethane	3-16	3-16
Inspection	3-17	3-17
MIL-C-53039	3-18	3-17
Touch Up of Conductive Coating on UH-60 Cockpit Door	3-19	3-29
CHAPTER 4		
TACTICAL PAINT SCHEME		
Section I. Helicopters		
General.....	4-1	4-1
External Areas not to be Painted.....	4-2	4-1
Preparation of MIL-C-46168.....	4-3	4-2
Procedures for Application of MIL-C-46168 Paint to Bare Metal Substrates.....	4-4	4-3

TABLE OF CONTENTS — Continued

	<u>Paragraph</u>	<u>Page</u>
Section II. Fixed Wing Aircraft		
General	4-5	4-3
Materials	4-6	4-3
Procedure	4-7	4-3
Section III. Markings		
General	4-8	4-4
Section IV. Propeller Assemblies and Blades		
General	4-9	4-4
Section V. Aircraft Components		
General	4-10	4-4
Section VI. Application to Previously Painted Surfaces		
General	4-11	4-4
Touch Up and Repair with MIL-C-46168	4-12	4-4
Touch Up and Repair with MIL-L-46159	4-13	4-5
Preparation of MIL-L-46159	4-14	4-5
Procedures for Application Over Properly Prepared Surfaces	4-15	4-5

CHAPTER 5. NON-TACTICAL PAINT SCHEMES

Section I. General		
Scope	5-1	5-1
Authority	5-2	5-1
Funds for Non-Tactical Paint Schemes	5-3	5-1
When to Paint Non-Tactical Paint Schemes	5-4	5-1
Paint Identification	5-5	5-2
Shade Numbers	5-6	5-2
Finishing System	5-7	5-2
Section II. Specific		
Rotor Blades and Propeller Assemblies	5-8	5-2
Markings	5-9	5-2
Training Aircraft	5-10	5-2
Aircraft in Congested Areas.. . . .	5-11	5-3
Aircraft for Arctic and Desert.. . . .	5-12	5-3
Test Support Aircraft	5-13	5-3
Medical Research & Geodetic Aircraft	5-14	5-3
Greenland Icecap Aircraft	5-15	5-3
Medical Service Aircraft	5-16	5-3
Military Assistance Program Aircraft	5-17	5-3
Staff Transport (VIP) Aircraft	5-18	5-3
Research & Development Aircraft	5-19	5-4

TABLE OF CONTENTS — Continued

	<u>Paragraph</u>	<u>Page</u>
CHAPTER 6. FINISHES FOR SPECIFIC APPLICATIONS		
Section I. General		
Aircraft Finishes	6-1	6-1
Surface Preparation	6-2	6-1
Application	6-3	6-1
Colors	6-4	6-1
Decals	6-5	6-1
Section II. Propeller Assemblies and Rotor Blades		
General	6-6	6-2
Propellers	6-7	6-3
Main Rotor Blades	6-8	6-4
Tail Rotor Blades	6-9	6-4
Section III. Aircraft Exterior Landing Gear & Wheels		
Landing Gear	6-10	6-5
Wheels	6-11	6-5
Section IV. Walkway Coatings		
Walkways	6-12	6-5
Anti-Glare Coatings	6-13	6-12
Battery Compartments	6-14	6-12
High Temp Areas	6-15	6-13
Rubber	6-16	6-13
Antennas and Radomes.	6-17	6-13
Section V. Interior Painting		
General	6-18	6-14.1
MIL-C-46168 Aircraft Black #37038 Polyurethane Paint, Crewstation Surfaces	6-19	6-14.1
MIL-C-22750 Epoxy Paint, Interior Surfaces other than Crewstation	6-20	6-15
MIL-C-46168 Interior Aircraft Gray #36231	6-21	6-15
Procedures	6-22	6-15
Application	6-23	6-16
Application with Spray Equipment	6-24	6-16
Application with Brush or Rollers	6-25	6-17
Typical Aircraft Interior Areas To Be Painted	6-26	6-17
Typical Aircraft Interior Areas Not To Be Painted	6-27	6-17
Decals, Placards, Markings, Labeling in Cockpit Area (When Used)	6-28	6-17
Emergency Exit Markings	6-29	6-19

TABLE OF CONTENTS — Continued

	<u>Paragraph</u>	<u>Page</u>
Section VI. Protective Coatings		
Coatings for Fiber Laminate Materials	6-30	6-20
Protective Coatings for Rain Erosion	6-31	6-20
Preparation of Surface	6-32	6-21
Application of Primer and Coating	6-33	6-21
Patching or Retouching Damaged Coating	6-34	6-22
Removal of Coatings	6-35	6-22
Removal of Paint from Radomes.	6-36	6-23
Protective Coating for the Canopy Egress System	6-37	6-23
CHAPTER 7. LETTERING AND MARKING		
Section I. Markings		
General	7-1	7-1
Section II. insignia: General		
Lettering and Marking Materials..	7-2	7-1
General	7-3	7-1
Colors	7-4	7-2
Applications	7-5	7-2
Fixed Wing Aircraft	7-6	7-2
Helicopters	7-7	7-3
Section III. Medical Insignia		
Aircraft	7-8	7-3
Aircraft First Aid Kits and Litters	7-9	7-3
Section IV. Command and Organizational Insignia and Name		
General	7-10	7-4
Color, Location, and Size...	7-11	7-4
Section V. Identification Lettering		
General	7-12	7-6
Fixed Wing Non-Tactical	7-13	7-6
Helicopters, Non-Tactical..	7-14	7-6
Section VI. Warning Stripes and Signs		
Propeller and Rotor Blade Warnings, Non-Tactical Aircraft	7-15	7-7
OV-1 Aircraft	7-16	7-7
Noise Hazard Labels and Stencils	7-17	7-7
Section VII. Radio Call Numbers and Prefixes		
Radio Call Numbers...	7-18	7-9

TABLE OF CONTENTS – Continued

	<u>Paragraph</u>	<u>Page</u>
Section VIII. Serial Number and Fuel Specification		
Fuselage	7-19	7-10
Markings	7-20	7-10
Section IX. Markings for Emergency Entry or Exit		
General	7-21	7-11
Secondary Openings	7-22	7-11
Relocation	7-23	7-11
Escape Panels -Internal Markings	7-24	7-11
Escape Panels -External Markings (Non-Tactical Aircraft)	7-25	7-12
Section X. Miscellaneous Markings		
General	7-26	7-12
Bilingual Markings	7-27	7-12
Markings for Tank Areas and Internal Station Markings	7-28	7-12
Oxygen Outlets	7-29	7-13
Lift Points	7-30	7-13
Strut Numbers	7-31	7-13
Electrical Connections	7-32	7-13
Walkways	7-33	7-13
NATO Symbol Markings of Aircraft Servicing Points	7-34	7-13
Aircraft Plates for General Officers	7-35	7-14
Jettisonable Components	7-36	7-14
Fluid Line Identification	7-37	7-14
Storage Batteries	7-38	7-14
American Flag Decals	7-39	7-15
Description of Exterior Paint System	7-40	7-15
Section XI. Marking of Instruments		
General	7-41	7-16
Method of Marking	7-42	7-18
Application of Marking	7-43	7-18
Marking for Reciprocating Engine Aircraft	7-44	7-20
Marking for Jet Engine Aircraft	7-45	7-23
Marking for Helicopters	7-46	7-24
Marking for All Aircraft	7-47	7-25

TABLE OF CONTENTS — Continued

	<u>Paragraph</u>	<u>Page</u>
CHAPTER 8. MISCELLANEOUS TABLES AND ILLUSTRATIONS . . .		8-1
CHAPTER 9. HELICOPTER ILLUSTRATIONS		9-1
Section I. AH-1 Illustrations		9-1
Section II. AH-64 Illustrations		9-13
Section III. CH-47 Illustrations		9-33
Section IV. CH-54 Illustrations		9-85
Section V. OH-6 Illustrations		9-101
Section VI. OH-58 Illustrations		9-109
Section VII. TH-55 Illustrations		9-127
Section VIII. UH-1 Illustrations		9-128
Section IX. UH-60 Illustrations		9-178
CHAPTER 10. FIXED WING AIRCRAFT ILLUSTRATIONS		
Section I. General		10-1
Section II. C-12 and RC-12 Illustrations		10-2
Section III. OV-1 and RV-1 Illustrations		10.30
Section IV. T-41 Illustrations		10-56
Section V. T-42 Illustrations		10-64
Section VI. U-3 Illustrations.		10-67
Section VII. U-8 Illustrations.		10-76
Section VIII. U-21 and RU-21 Illustrations		10-89

LIST OF TABLES

	<u>Page</u>
Table 3-1	Spray Coating Troubles, Possible Causes and Remedies 3-18
Table 6-1	Typical Aircraft interior Areas to be Painted (5 sheets) 6-6
Table 6-2	Typical Aircraft Interior Areas Not to be Painted (6 sheets) 6-9
Table 8-1	Technical Manuals, Technical Bulletins, and ARs 8-1
Table 8-2	Standards 8-1
Table 8-3	Consumable Items List 8-2
Table 8-4	State Abbreviations 8-8
Table 8-5	Definitions of Common Paint Terms 8-9
Table 8-6	Ventilation and Respirator Requirements for Application of Paints 8-16
Table 8-7	Current Safety Guidelines for Application of MIL-C-46168B Paint 8-17
Table 8-8	Recommended Respiratory Protection Guidelines for Spray Finishing Operations 8-18
Table 8-9	Occupational Health Protection Requirements for Paint Spray Workers Using MIL-E-52798A Alkyd Enamel and MIL-C-46168B Polyurethane Coating 8-19

LIST OF ILLUSTRATIONS

<u>Figure</u>	<u>Title</u>	<u>Page</u>
1-1	MIL-C-46168 Identifier Symbol	1-3
3-1	Right and Wrong Methods of Spraying	3-9
3-2	Cross-Coating	3-10
3-3	Fifty Percent Overlap	3-10
3-4	Setting Spray Pattern	3-12
3-5	Faulty Patterns and Suggested Corrections	3-13
3-6	Excessive Spray Fog	3-24
3-7	Paint Leaks from Spray Gun	3-24
3-8	Gun Sputters Constantly	3-24
3-9	Orange Peel	3-25
3-10	Sandpaper Finish	3-25
3-11	Wrinkling	3-25
3-12	Crazing	3-26
3-13	Checking	3-26
3-14	Blistering	3-26
3-15	Fish-Eyes and Poor Wetting, Crawling, Poor Flowout	3-27
3-16	Lifting	3-27
3-17	Pitting or Cupping	3-27
7-1	Command and Organizational Insignia and Name	7-5
7-2	Size and Wording of Stencil	7-8
7-3	Sample Markings	7-17
7-4	Method of Marking	7-18
7-5	Mixture Control Quadrant	7-19
7-6	Typical Manifold Pressure Gage, Tachometer, Cylinder Head Temperature Gage, and Air Temperature Gage Markings	7-21
7-7	Typical Coolant Temperature Gage and Torquemeter Markings	7-22
7-8	Typical Tachometer and Engine Exhaust Temperature Gage Markings	7-23
7-9	Typical Dual Tachometer Markings	7-24
7-10	Typical Oil Pressure Gage, Oil Temperature Gage, and Airspeed Indicator Markings	7-26
7-11	Typical Accelerometer, Hydraulic Pressure Gage, Deicer Gage, and Fuel Pressure Gage Markings	7-27
7-12	Fuel Nozzle Grounding Dimensions	7-29
8-1	National Star Insignia	8-20
8-2	Wing and Fuselage Marking (Typical)	8-22
8-3	NATO Marking Symbols	8-23
8-4	Sidedraft Paint Booths	8-27
8-5	Downdraft Paint Booths	8-28
8-6	Typical Compartment Markings	8-29
8-7	First Aid Kit	8-29
8-8	Optimum High Visibility Paint Scheme, Two Blades, Exposed Hub	8-30
8-9	Optimum High Visibility Paint Scheme, Two Blades, Helicopter Tail Rotor Only ...	8-31
8-10	Optimum High Visibility Paint Scheme, Two Blades with Spinner	8-32
8-11	Optimum High Visibility Paint Scheme, Three Blades, Exposed Hub	8-33
8-12	Optimum High Visibility Paint Scheme, Three Blades, With Spinner	8-34
8-13	Optimum High Visibility Paint Scheme, Four Blades, Exposed Hub	8-35
8-14	Optimum High Visibility Paint Scheme, Four Blades, Helicopter Tail Rotor only	8-36
9-1	Tactical Paint Scheme, AH-1	9-1
9-2	Exterior Markings, AH-1	9-2

LIST OF ILLUSTRATIONS-Continued

<u>Figure</u>	<u>Title</u>	<u>Page</u>
9-3	Station Diagram, AH-1	9-12
9-4	Tactical Paint Schemes, AH-64	9-13
9-5	Exterior and Interior Markings, AH-64	9-14
9-6	Station Diagram AH-64	9-32
9-7	Tactical Paint Scheme, CH-47	9-33
9-8	Non-Tactical Arctic/Desert Paint Scheme, CH-47	9-34
9-9	Interior Markings CH-47	9-35
9-10	Exterior Markings, CH-47	9-55
9-11	Station Diagram, CH-47	9-84
9-12	Tactical Paint Scheme, CH-54	9-85
9-13	Non-Tactical Arctic/Desert Paint Scheme, CH-54	9-86
9-14	Exterior and Interior Markings, CH-54	9-87
9-15	Interior Markings, CH-54 Universal Pod	9-94
9-16	Exterior Markings, CH-54 Universal Pod	9-97
9-17	Tactical Paint Scheme, OH-6	9-101
9-18	Non-Tactical Arctic/Desert Paint Scheme, OH-6	9-102
9-19	Exterior Markings, OH-6	9-103
9-20	Station Diagram. OH-6	9-108
9-21	Tactical Paint Scheme, OH-58	9-109
9-22	Non-Tactical Arctic/Desert Paint Scheme, OH-58	9-110
9-23	Interior and Exterior Markings, OH-58	9-111
9-24	Interior Requirements to be Stenciled on the Back of Pilot's and Co-Pilot's Seat Backs, OH-58A/C	9-124
9-25	Station Diagram, OH-58	9-126
9-26	High Visibility Markings TH-55	9-127
9-27	Tactical Paint Scheme, UH-1C/M	9-128
9-28	Non-Tactical Arctic/Desert Paint Scheme, UH-1C/M	9-129
9-29	Interior Markings, UH-1C and UH-1M	9-130
9-30	Exterior Markings, UH-1C and UH-1M	9-134
9-31	Station Diagram, UH-1C and UH-1M	9-152
9-32	Tactical Paint Scheme, UH-1 H/V	9-153
9-33	Non-Tactical Arctic/Desert Paint Scheme, UH-1H/V	9-154
9-34	Staff Transport UH-1D/H	9-155
9-35	Army Medical Service (Ambulance) UH-1D/H	9-156
9-36	Interior Markings, UH-1D and UH-1H	9-157
9-37	Exterior Markings, UH-1D and UH-1H	9-161
9-38	Station Diagram, UH-1D and UH-1H	9-177
9-39	Tactical Paint Scheme, UH-60	9-178
9-40	Non-Tactical Arctic/Desert Paint Scheme, UH-60	9-179
9-41	Exterior and Interior Markings, UH-60	9-180
9-42	Army Medical Service (Ambulance), UH-60	9-181
9-43	Station Locations; UH-60	9-201
10-1	Exterior Markings, C-12	10-2
10-2	Station Diagram, C-12	10-29
10-3	Tactical Paint Scheme, OV-1D and RV-1D	10-30
10-4	Exterior Markings, OV-1D and RV-1D	10-32
10-5	Aero 65 Bomb Rack and External Fuel Tank Markings, OV-1	10-47

LIST OF ILLUSTRATIONS – Continued

<u>Figure</u>	<u>Title</u>	<u>Page</u>
10-6	Warning Stencil for Vaneaxial Fan, OV-1 Incorporating Air-Conditioning Systems	10-51
10-7	Aero 15 Bomb Rack Markings, OV-1.	10-52
10-8	Station Diagram, OV-1	10-53
10-9	Exterior Markings, T-41B	10-56
10-10	Station Diagram. T-41B	10-63
10-11	Exterior Markings, T-42	10-64
10-12	Station Diagram, T-42	10-66
10-13	High Visibility Paint Scheme, U-3A and U-3B	10-67
10-14	Exterior Markings, U-3A and U-3B	10-71
10-15	High Visibility Paint Schemes, U-8F	10-76
10-16	Exterior Markings, U-8F	10-77
10-17	Station Diagram, U-8F	10-88
10-18	Tactical Paint Scheme, RU-21	10-89
10-19	Non-Tactical Paint Scheme, U-21	10-91
10-20	Non-Tactical. High Visibility Paint Scheme, U-21.	10-95
10-21	interior Markings, U-21 and RU-21	10-97
10-22	Exterior Markings, U-21 and RU-21	10-102
10-23	Station Diagram, U-21 and RU-21	10-115

CHAPTER 1

GENERAL

Section I. PURPOSE AND SCOPE

1-1. PURPOSE. This manual provides instructions and procedures for the painting and marking of all Army aircraft, including standard approved materials, application and maintenance of coatings, finishing materials, special purpose coatings and markings, insignia, and identification markings.

NOTE

Paragraph 7-34 should be consulted prior to painting and marking of all aircraft, in order to assure compliance with NATO STANDARDIZATION AGREEMENT (STANAG) No. 3109 ABC AIR STD 5 1/2 AND STANAG 3230.

1-2. SCOPE. The paint schemes and materials prescribed by this TM are mandatory for all Army aircraft whether assigned for active service, storage, under procurement, or involved in research and development. This TM is applicable to all Army Reserve National Guard, and major Army field commands as defined in AR 10-5, Section III. Commencing Oct 85, "New procurements and those assets that require depot maintenance will include polyurethane (MIL-C-46168) and/or MILC22750, Epoxy as noted in this publication."

1-3. RESTRICTIONS. Satisfactory protective coatings applied prior to the issuance of this TM will not be altered solely for the purpose of conformity to current painting and marking requirements. Complete painting will be accomplished only when the existing finish has been obsoleted or deteriorated to the extent that it fails to protect the underlying surfaces or the finish must be changed for policy reasons as authorized by higher authority.

1-4. DEVIATIONS. Deviations from the provisions of this technical manual must be approved by Department of the Army. Request for deviation or change will be supported by justification (such as safety, mission requirement, cost reductions etc.) and forwarded to U.S. Army Aviation and Troop Command, ATTN: AMSATI-ME, 4300 Goodfellow Boulevard, St. Louis MO 63120-1798. Wherever the instructions in this technical manual conflict with the instructions in the publications referenced herein, the instructions in this technical manual will be followed.

Section II. RESPONSIBILITIES

1-5. ORGANIZATIONAL ACTIVITIES.

a. Aviation Unit Maintenance (AVUM). Responsible for surface preparation and minor touch-up (spot painting) of aircraft surfaces. Touch-up is defined as minor repainting of the painted aircraft surface, i.e., light scratches, chipping, crazing, small wear spots around doors, cowling, areas where there is heavy foot traffic, towing points, minor sheet metal repairs and necessary blanding to improve appearance. Touch-up for coating, aliphatic polyurethane per MIL-C-46168, see para 4-12; for lacquer, acrylic, per MIL-L-46159, see para 4-13.

b. Aviation Intermediate Maintenance (AVIM). Responsible for repainting deteriorated aircraft painted surfaces that are beyond the capabilities authorized for AVUM. Repainting is defined as stripping paint down to the bare substrate, inspecting for corrosion, pretreatment for corrosion, priming and topcoating of large areas of aircraft painted surfaces. Repainting will only be done if equipment and facilities indicated in Chapter 3 are available

c. Aircraft Components. Assemblies and components received in primed condition will be touched up with primer as necessary to repair damaged coating, prior to application of top coat, and will be finish-coated to match adjacent and interrelated structural surfaces. Internal airframe components within crewstations shall be painted Aircraft Black, #37038, per MIL-C-46168. Internal airframe components located in, or adjacent to, cargo compartments shall be painted interior Aircraft Gray, #36231, per MIL-C-46168. Internally installed components will be touched up or refinished using MIL-C-22750 or MIL-C-46168 with required colors. All external dynamic components will be top coated with Aircraft Black, #37038, per MIL-C-46168.

1-6. AVIATION DEPOT MAINTENANCE.
Responsible for surface preparation and refinishing the

entire aircraft. Refinishing is defined as stripping down the complete aircraft to bare substrate, inspecting for corrosion, pretreating for corrosion, priming and repainting to a like new condition. Depot level maintenance activities will also perform work assigned to lower echelons of maintenance.

1-7. INTERNATIONAL STANDARDIZATION. The aircraft marking provisions of this Technical Manual are subject to international standardization agreement (ABC AIR STD. 5 1/2, STANAG 3109, and STANAG 3230.) When amendments, revisions, or cancellation of this Technical Manual are proposed, the department custodians will inform their respective standardization offices so that appropriate action may be taken respecting the international agreement concerned

Section III. AUTHORIZED PAINT SCHEMES

1-8 GENERAL. The following aircraft may be completely repainted only with authority for deviation from AMSAT-I-MEA: Standard C (STD C) aircraft, Limited Standard (LS) aircraft, Obsolete (OBS) aircraft, aircraft designated Contingency Category (C and T), and aircraft used by the Army on loan from another agency. They will otherwise be maintained in their existing paint scheme by spot painting to prevent corrosion and deterioration. See paragraph 1-4 for deviations from the provisions of this technical manual.

1-9. TACTICAL AIRCRAFT PAINTING.

a. All Army aircraft, except those specifically exempted in paragraph 1-10, will be painted the tactical paint scheme as specified in Chapter 4.

b. All TOE/MTOE (Table(s) of Organization and Equipment/Modified Table(s) of Organization and Equipment) helicopters will be painted to the tactical paint scheme of aircraft green polyurethane per MIL-C-46168 applied with lusterless markings.

c. Army helicopters having a top coat of aircraft green acrylic lacquer applied per MIL-L-46159 will be converted to MIL-C-46168 Aircraft Green paint during commercial or organic aircraft overhaul. Aircraft may be painted on other occasions at the discretion of the major field commanders.

d. The tactical external topcoat for fixed wing aircraft will be aircraft gray with black markings. Material will conform to MIL-C-46168.

e. Crewstations and components within crewstations shall be finished Aircraft Black, #37038, per MIL-C-46168.

f. Aircraft cargo compartments of applicable aircraft should be painted interior Aircraft Gray, #36231, conforming to MIL-C-22750 or MIL-C-46168, except OH-6 and OH-58 aircraft shall be painted Aircraft Black.

g. Both pilot and gunner stations of AH-1 and AH-64 aircraft shall be Aircraft Black.

1-2 Change 7

h. Internal components located in or adjacent to cargo compartment areas shall be finished to match internal airframe color.

i. All aircraft that have been painted or repainted with MIL-C-46168 should be marked with the polyurethane paint symbol as indicated in Figure 1-1. The date (month and year) and MIL-C-46168 designation shall be as shown. The paint scheme used shall be shown in the manner and location specified in paragraph 7-40. The polyurethane paint symbol shall be to the left of the airframe. Aircraft components with insufficient sur-

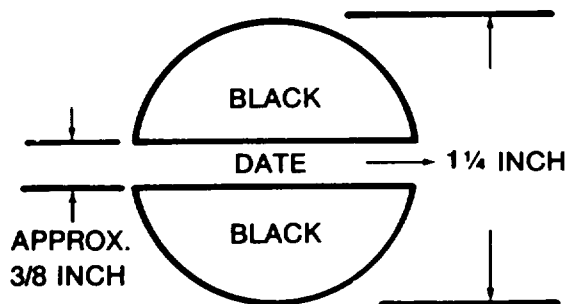


Figure 1-1. MIL-C-46168 Identifier Symbol

face to apply the symbol, will be marked on the surface of the component that would not normally be visible from outside the aircraft. With either chemical agent resistant coating polyurethane (CARC-P) or chemical agent resistant coating epoxy (CARC-E) using 1/4 inch lettering.

1-10. EXCEPTIONS TO TACTICAL AIRCRAFT PAINTING.

a. Medical air ambulances will be painted in accordance with the instructions in Chapter 5.

b. TDA helicopters may be painted to the tactical paint scheme but retain high visibility/conspicuity markings described in Chapter 5. Aircraft in this category that are used for training purposes at Army aviation schools and other facilities may be banded with fluorescent paint or tape to ensure better daylight inflight visibility. Refer to Chapter 9.

c. Aircraft designated for a specific mission or assigned to certain geographic locations may be painted variations to the tactical paint of Chapter 4. See Chapter 5 for information clarifying these non-tactical paint schemes.

CHAPTER 2

SURFACE PREPARATION

Section I. CLEANING

2-1. GENERAL. In the process of preparing surfaces for stripping or painting, care should be taken that the surfaces are dean and free from dirt, grease, lint, water or other substances which may interfere with full contact with the surface. Conventional cleaning may be used in this process, as follows:

a. Cleaning of surfaces, as covered by this paragraph is intended to remove traces of dust or contamination just prior to painting. For complete details on materials and surface cleaning preparatory to stripping, consult TM 1-1500-344-23.

b. Cleaning shall be accomplished with solvents, detergents and processes which have no degrading effect on the surfaces and which produce surfaces satisfactory for receiving subsequent processing. There are cleaning materials which are effective and suitable for some surface contaminants, e.g., grease and oils, and which are not suitable for others. More than one cleaning product may, therefore, be required to provide a waterbreak-free surface.

c. For conventional surface cleaning prior to metal treatment processing, primer or topcoat application, use the process cited in TM 1-1500-344-23.

NOTE

Acid cleaners or surface treatments other than those cited in TM 1-1500-344-23 or this publication shall not be utilized. These materials may cause hydrogen embrittlement to high strength steels and deteriorative effects on other alloys.

NOTE

Reclaimed paint thinner or other reclaimed thinners shall not be used for cleaning purposes. These materials may leave a grease film which will cause poor adhesion of the next coat or form a barrier which removers cannot effectively penetrate.

Section II. STRIPPING

2-2. GENERAL. The foremost considerations in removing organic coatings are that removal is complete to the bare metal, or polyamide primer, and that no damage occurs in the process to underlying surfaces. A

variety of methods can remove coatings. In choosing one, a compromise must be made between maximum uncontrolled removal power and protection of equipment being stripped.

WARNING

Military Specification MIL-R-81294 may be used on aluminum or magnesium substrates. Military Specification MIL-H-81294 remover contains highly volatile methylene chloride as a constituent. Its vapors are hazardous to breathe and/or will cause skin burns. Although methylene chloride is not flammable, other constituents are. When the blanketing effect of methylene chloride is lost through its volatility, the remaining constituents may, under certain conditions, become ignitable. Any paint remover on the skin or in the eyes must be flushed immediately and copiously with water. In addition, medical treatment should be sought promptly in the case of contact with the eyes. Protective clothing and equipment such as rubber gloves, aprons, boots, approved organic vapor cartridge respirators (TB MED 502), appropriate eye shields and goggles shall be used as necessary to provide adequate protection for personnel.

The painting operation should be reviewed by the installation safety office and MEDDAC Health and Environment Activity to determine the presence of any operational hazards and to make recommendations for either eliminating or controlling those hazards found.

CAUTION

Care must be exercised when using any paint remover on fiberglass/plastics (e.g., antenna, access doors, fairings, canopies) surfaces to avoid damage. Spot tests must be accomplished, on inconspicuous surfaces to determine compatibility of any remover, and a remover selected which does not cause

deterioration. Precautionary measures shall be taken to prevent paint and paint removal waste from contaminating lakes and streams. Some of the chemicals utilized for painting and paint removal require treatment or other special control prior to disposal. Disposal of materials shall be accomplished under the direction of the installation facility engineer and MEDDAC Health and Environment Activity in accordance with applicable directive, and in a manner that will not result in violation of local, state and federal pollution criteria. Guidelines for disposal are cited in AR 200-1.

2-3. METHODS. The specific method for stripping existing paint to bare metal is determined by the accessibility of the area, judgement of the degree and type of corrosion and degree of flaking or peeling of paint. Stripping may be accomplished by:

- a. Chemical Remover. See paragraphs 2-4, 2-6 and 2-7 below.
- b. Mechanical Means. See paragraph 2-9 below.

2-4. SURFACES NOT TO BE CHEMICALLY STRIPPED.

NOTE

MIL-R-81294 will deteriorate most non-metallic structures. Non-metallic surfaces may be stripped with specific AMCOM or local engineering approval. Subsequent damage must be repaired.

- a. Areas Not to be Exposed to Paint Remover.
 - (1) De-icer boots, wing and tail.
 - (2) De-icer element, leading edge of engine cowl-air intake.
 - (3) Wheel wells.
 - (4) Propellers.

(5) Propeller spinner or propeller control.

(6) Cockpit enclosures, including avionics panels, instruments, etc.

(7) Engine air intakes, tail pipe area. Battery and fuel vents and heater exhaust must be covered to keep out paint remover.

(8) Do not strip sealant presently applied under access covers. Any sealant removed will be replaced using adhesion sealant MIL-S-81733 Type II, Class B or low adhesion MIL-S-8784 molded in the form of a rubber gasket.

(9) Fiberglass wingtips and other fiberglass components, e.g., antennas and radomes.

b. The OV-1 Fuselage. The OV-1 fuselage is sealed at the fuselage skin joints; therefore, rapid paint stripping and thorough flushing is necessary.

Radomes. Radomes will not be stripped.

2-5. PROTECTION OF SURFACES NOT TO BE STRIPPED.

a. General.

(1) Mask all transparent plastic surfaces such as windows, canopies, blisters, etc. Plastic will be crazed, frost or lose transparency if paint remover comes in contact with them. Mask radomes in the same manner as plastics to prevent damage to their rain-erosion resistant and antistatic coatings. Also, mask boots or any exposed rubber or elastomer surfaces since remover will accelerate deterioration of these materials. Double masking of sensitive areas is recommended.

(2) Mask detailed decalcomania which cannot be easily replaced. Other instructions, stencils or warning signs will either be masked or replaced after repainting.

(3) Do not attempt to remove coating from loop antennas. Protect the housing from contact with remover,

(4) Mask all faying surfaces, seams, access doors, pitot static ports (area within a one (1) ch diameter), or other openings with barrier paper and tape.

(5) All edges, repairs and loose fasteners on all honeycomb panels shall be masked prior to chemical stripping,

(6) Mask over joints, access doors, or other openings or panels which have been bonded with adhesives. Paint remover has a detrimental effect on the strength of adhesives when allowed to contact them.

(7) Masking may be done with barrier paper, Military Specification MIL-B-131F or MIL-B-121, Type 1, Grade A, Class 1; tape, pressure sensitive adhesive, for masking during paint stripping, Military Specification MIL-T-23397, Type II (72 hour protection).

(8) Masking may also be done with paraffin wax, Federal Specification VV-W-95, in lieu of paper. Use only masking tape, MIL-T-21595, to outline area to be masked to keep wax off metal. Melt wax and brush a thick coat on surface. The temperature of the wax should be approximately 150°F (65°C), as higher temperature may deform plastic.

b. Masking of Seams. Masking of seams can be done with MIL-S-8784, Class B, sealant. Allow to cure to a firm rubbery state (approximately 20 hours at 60°F to 80°F) prior to starting the stripping operation. The required cure time for this material must be considered when flow or processing time is of prime importance. After the paint stripping operation is completed, the fillet formed by the MIL-S-8784, class B, material shall be peeled off by hand.



All masking or protective materials must be removed immediately upon completion of paint stripping and/or painting process.

2-6. GENERAL PREPARATIONS.

NOTE

The only chemical paint remover authorized for use on aircraft surfaces is MIL-R-81294. Other chemical removers cannot be used unless authorized by AMSAV-MEA.

a. Preparation.

(1) Place aircraft on a wash rack, preferably in a shaded area, and attach a static ground.

(2) For best results, ambient temperature should be approximately between 50° and 100°F (10° and 37°C). Do not attempt to accomplish paint removal in rain, or on aircraft surfaces which are not dry.

(3) When painted surface is exceptionally dirty or coated with fuel, oil, grease, mud, or other foreign matter, clean it before applying remover in accordance with paragraph 2-1.

b. Drying. After aircraft has been cleaned, allow sufficient time for surfaces and crevices to dry thoroughly. Water remaining on surfaces and in crevices has a detrimental effect on paint removers.

2-7. APPLICATION OF MIL-R-81294 PAINT REMOVERS.

CAUTION

Paint remover that is old is not necessarily unsatisfactory for use although it deteriorates progressively with age in removal effectiveness, particularly if subjected to open air and temperatures over 100 °Fahrenheit. More important, there is an increasing potential of corrosiveness upon its aging. Close surveillance shall be made of material age when it is to be used on aircraft surfaces. Any material which is questionable by reason of age, or improper storage, shall be laboratory tested for continued conformance to specification, with particular reference to the corrosive potential, prior to being used on aircraft surface. Any remover found not to be in accordance with Military Specifications will be discarded.

NOTE

Removers must be well mixed before use as they tend to segregate on standing. Do this by agitating with a

wooden paddle if mechanical mixers are not available, Rollings a drum will not mix its content very effectively. At temperatures below 60°F, the removal power of removers will be noticeably slower than at higher temperatures.

a. Applying Removers. Beginning at the highest point of any vertical or sloping surface, apply a coat of remover, with a long handle, nonmetallic brush. Barrel pump and spray gun may be used for application of removers. In no case should the spray be highly atomized. Agitate with a stiff fiber brush, if necessary, to loosen paint. A wet film of remover should be maintained on the surface being stripped to obtain efficient removal. This may require additional application of the remover. Areas should be treated progressively, kept wet, and sufficient time allowed for the stripping action. Best results are obtained by applying removers in shaded areas since sunlight dries the remover quickly,

WARNING

Prolonged breathing of remover fumes must be avoided. Use only in well ventilated areas.

NOTE

The OV-1 fuselage is sealed at the fuselage skin joints; therefore, rapid paint stripping and thorough flushing is necessary.

b. Painted Surfaces. Enamel surfaces should wrinkle within 5 to 15 minutes after application. Most surfaces with lacquer or polyurethane paint will not wrinkle but will merely be softened by the remover; allow remover to remain 8 to 20 minutes, keeping a wet surface by applying another coat of remover if necessary.

c. Cleanup of Stripped Surfaces.

(1) Flush the stripped surfaces, using water heated to 90° to 120° Fahrenheit at 150 to 250 psi maximum. If high pressure warm water is not available, cold water at usual hydrant pressure may be used. This will require a longer time to accomplish the washing. Lifted paint will be flushed by starting at the bottom and working upward, keeping the flushing liquids off the unwashed parts. After flushing thoroughly, continue cleaning in accordance with TM 1-1500-344-23.

NOTE

Zinc chromate primed surfaces, where topcoat material has not been applied, should be washed down as soon as possible after initial loosening of primer. If the surface becomes dry, another application of remover is required since zinc chromate tends to become re-deposited on the surface.

(2) Tape and loosened paint may be removed by hand or by using water under pressure.

2-8. STRIPPING IN CONFINED LOCATIONS.

a. Removal of Paint with Solvent Materials. When impractical to use emulsified paint remover because of complexities of assembly and rinsing difficulties, remove acrylic paint with solvent materials such as ethyl acetate, Federal Specification TT-E-751, lacquer thinner, Federal Specification TT-T-266, or dichloromethane, Military Specification MIL-D-6998; remove polyurethane paint by mechanical means.

WARNING

Prolonged breathing of solvent fumes must be avoided. Use only in well ventilated areas.

b. Application of Solvents

(1) After appropriate masking, apply solvents with soft bristle brush or clean cloth.

(2) Allow solvent to remain on surface until paint has softened and lifted. To keep the area wet with solvent, it may be necessary to keep a cloth on the surface and keep the cloth saturated with solvent.

(3) Wipe all of the solvent away with a clean damp cloth, frequently rinsing cloth in clean water.

(4) Repeat steps (1) through (3) as necessary until all paint and residue have been removed from metal surface including recesses and around rivets, bolts, etc.

(5) Wipe clean and dry with clean lint-free cloth, Federal Specification CCC-C-46.

2-9. MECHANICAL REMOVAL FROM METALS.

Mechanical removal of paint is recommended where chemical removal would be impractical because of structural complexities, rinsing difficulties, or where it is more efficient or environmental restrictions on chemical exists.

a. Hand removal may be accomplished using:

(1) An abrasive nylon mat, Military Specification MIL-A-9962; aluminum wool, Military Specification MIL-A-4864, or Federal Specification P-P-101 No. 400 abrasive paper. Do not use steel wool.

(2) A hand operated air powered drill motor with rotary brass wire brush or abrasive flap brush on heavy structural non-clad aluminum alloys.

WARNING

The use of goggles or face shield is mandatory since paint particles can break loose and fly off.

CAUTION

Do not use steel brush or steel wool on non-ferrous surfaces. Metal particles will become embedded in the substrate, causing corrosion by galvanic action between dissimilar metals.

(3) Wipe area with clean damp cloth followed by wiping dry, with a clean, dry lint-free cloth. Areas may be blown with warm oil-free air or gaseous nitrogen.

WARNING

Magnesium-Thorium Alloy Components of T-53, T-55 and T-63 engines contain radioactive material. The mechanical method of corrosion removal shall be attempted only under the operating procedures required by TB 43-0108.

b. Abrasive Blasting. Abrasive blasting (a rapid method) consists of bombarding a surface with an

abrasive at high velocity. The abrasive may be glass beads, steel grit or organic materials and is carried to the surface by air at high velocity. This should not be applied on surface where critical dimensions must be maintained or on thin structures which can warp.

c. Wire Brushing. Wire brushing is a mechanical abrasive operation done usually with a hand wire brush or a wire brush mounted on a motor driven wheel. By using different types of brushes and various lengths and gages of wire, a wide range of abrasive action is possible. Use wire brushing to remove heavy corrosion and imbedded paint, especially where chemical treatment is not practical. A typical wire brushing procedure follows:

(1) Protect adjacent components from scale, chips, and dust.

(2) If grease or oil are present, clean area by method outlined in paragraph 2-1 or TM 1-1500-344-23.

(3) Wire brush area to a firm metal subsurface.

WARNING

The use of goggles or face shield is mandatory when using motor-driven brushes.

2-10. SPECIAL CONDITIONS. Where difficulty is encountered on magnesium surfaces, paint may be removed by following instructions in Military Specification MIL-M-3171, Processes for

Pretreatment and Prevention of Corrosion on Magnesium Alloy. Do not blast flexible braided metal lines such as copper or stainless steel. Use only clean abrasive on Titanium Alloys.

Section III. METAL CONDITIONING

2-11. METAL TREATMENT. Aluminum and magnesium surfaces to be painted will be cleaned prior to painting and prior to the application of the chemical treatment specified in paragraph 2-12 with a bristle brush using any of the cleaning compounds or processes listed in TM 1-1500-344-23.

2-12. CHEMICAL COATINGS (CONVERSION COATINGS).

a. Chemical Treatment of Aluminum Surfaces. Surfaces will be cleaned prior to application of chemical coating. Chemical treatment of aluminum will be as follows:

(1) General. Chemical surface treatment, such as alodine, provides a passive surface layer that resists corrosion and provides a necessary base for bonding the paint to the aluminum.

(2) Materials. Treatment materials will conform to Military Specification MIL-C-5541.

(3) Application.

(a) Prepare and apply in accordance with manufacture's instructions. In general, mix 1-1/4 ounces of compound with each gallon of water.

(b) Apply solution to perfectly cleaned but wetted surfaces.

(c) Apply solution liberally and evenly to only as much surface at a time as can be coated and rinsed before surface treatment solution dries. When the surface action appears complete on all areas, stop the reaction by rinsing or flooding the area with fresh, clean water. The reaction of the solution is stopped by diluting the

acid component. Be careful not to flush the solution into areas where it cannot be removed and/or further diluted by water. Accidental spills in confined areas can be neutralized using baking soda followed by rinsing with clean water. Allow the surface to drain and/or pick up the excess water by absorbing in a sponge by blotting action: do not rub. Excess rubbing will remove the coating since it is soft.

b. Chemical Treatment of Magnesium Surfaces. Treat magnesium surfaces to be painted in accordance with Military Specification MIL-M-3171. Apply strictly in accordance with manufacturer's instructions.

2-13. PRETREATMENT AND SEALING OF BARE METAL SURFACES.

o. Aluminum bare metal will be alodine treated per MIL-C-5541, Class 1A, prior to applying the first primer.

b. Bare magnesium metal areas will be bichromate treated per MIL-M-3171, Type 6, prior to applying the first primer.

NOTE

Paint will not bond to the brown powdery surface of excessively treated magnesium or aluminum, nor will paint bond to treated aluminum surfaces which are too dark.

c. Steel substrates will be treated with zinc phosphate per TT-C-490, Type 1, prior to applying the first primer.

d. All missing or deteriorated skin sealant will be replaced using MIL-S-81733, Type II, Class B, sealing compound.

CHAPTER 3

PAINTING: GENERAL

Section I. PAINTING TECHNIQUES

3-1. STORAGE OF PAINTING MATERIALS. To prevent fire, spoilage, and waste arising from improper storage and surplus stock, the following precautions shall be observed.

WARNING

Space heaters or other direct fired heaters shall not be used to heat storage areas. Floors should be concrete and drained to one point; drain shall run to sump or detached cistern and have deep trap. Ventilation shall utilize screened inlets 6 inches above floor and screened vent through roof.

a. Paint and thinners shall be stored where possible in dry, fire resistant well drained and well ventilated structures, preferably separated from other buildings, and under automatic sprinkler protection.

b. To avoid possible leakage arising from corrosion of containers, protection shall be provided against wetting by rain, snow, steam leaks, or other sources of water.

c. Materials shall not be stored in the proximity of steam lines or other sources of heat to avoid direct heat. It is recommended that steam heat be used with coils above stock and screened to prevent contact with drums or containers.

d. Storage shall not be on floors below grade and first tier of containers shall be laid at least 2 inches above floor level to provide for suitable ventilation and drainage. Sills shall be provided at openings to storage areas, approximately 6 inches above floor

e. Paint components and thinners packaged in 55 gallon steel drums may be stored outdoors provided containers are protected against rusting by painting of bare metal areas and are set on dunnage so as to provide approximately 2 inches clearance above ground. Drums stored out of doors shall be laid on their sides to protect loss of markings stenciled on the heads through weathering action of rain, snow, and sun.

f. Handling of stock shall be conducted in a manner to avoid damage to labels. Relabeling of material where labels have been obliterated may result in mislabeling, with consequent incorrect use or waste of material. Materials with obliterated labels should be properly discarded.

g. Care should be taken to assure protection of the paint or components from moisture. Particular care should be exercised to prevent water entering containers as paint is opened.

h. Containers of paint materials shall be readily accessible at all times. Other materials shall not be stacked on top of paint materials.

i. Containers shall be stored and issued in order of dates of manufacture shown on respective labels. Materials bearing oldest date shall be used first. In the event that date of manufacture is not shown on container, date of receipt shall be considered as approximate date of manufacture for purposes of storage and issue.

j. To give best results, temperature of paint materials should be between 60° and 85° F (18° and 29° C) at time of use. Storage conditions that result in paint temperatures below 55° F (13° C) or above 95° F (35° C) require storage of material at room temperature for approximately 25 hours prior to use.

k. Transit and Storage - In closed containers, temperature and humidity will not affect the stability of either component of two part coatings. Both components will remain stable for 1 year, as long as the component B, the catalyst portion, remains in closed and sealed containers. Where it is necessary to extract a portion of the component B, it should be done in a cool location and the lid resealed as rapidly and as tightly, as possible.

3-2. SAFETY AND HEALTH ASPECTS OF PAINTING.

CAUTION

Federal and state environmental regulations are applicable to all chemicals used in painting processes. Precautionary measures shall be taken to prevent paint and paint removal waste from contaminating lakes and streams. Some of the chemicals utilized for painting and paint removal require treatment or other special control prior to disposal. Disposal of materials shall be accomplished under the direction of the installation facility engineer and MEDDAC Health and Environmental Activity in accordance with applicable directives, and in a manner that will not result in violation of local, state and federal pollution criteria. Guidelines for disposal are cited in AR 200-1.

Painting operations present hazards that require control or preventive measures. Vapors produced, particularly in spray painting, are highly flammable, as are the accumulated dried coating materials deposited on walls, floor and equipment in painting areas. Coating materials and their thinners very often contain toxic substances which are injurious to health by inhalation and, to a less degree, by physical contact. Painting operations also involve hazards resulting from the improper use of work stands, ladders, hoists, etc. All painting personnel shall take all requisite safety precautions with regard to toxicity and other

health hazards, and flammability hazards in accordance with existing instructions and regulations. All safety precautions regarding personnel health, fire prevention, ventilation, handling of equipment, electrical grounding, storage of coating materials, area preparation, use of vapor-proof lights, etc., are mandatory.

a. Personnel Safety Measures. The following measures are minimum requirements for personal safety.

(1) Wear protective clothing to prevent contamination of ordinary clothing.

(2) Aprons and clothing that become saturated with paint should not be worn in shop. Saturated clothing shall not be hung in lockers or other similar confined spaces that might induce spontaneous combustion.

(3) All personnel should wear non-sparking shoes, which are free from metal nails in soles and heels.

(4) Full skin covers, i.e., gloves or skin protective creams shall be applied to exposed skin areas prior to painting to guard against injurious effects of paints, and to allow ready removal of paints by washing the area with water. Skin areas shall be clean and dry before cream is applied.

WARNING

Certain paint solvents and pigments may cause dermatitis on coming in contact with the skin. Some solvents may penetrate skin, or may be inhaled as vapors, and lead to systemic poisoning. Care must be taken to avoid skin contact or breathing vapors to avoid systemic poisoning.

(5) Personnel engaged in stripping or Cleaning with methylethylketone (MEK), acetone or toluene and spray application of paints shall wear an approved organic vapor cartridge respirator approved by the Operational Safety and Health Administration (OSHA). (See Tables 8-7 through 8-9).

(6) Wash thoroughly after painting and before eating, and do not carry food into spraying areas.

(7) Spray paint only when adequate exhaust or general ventilation is available.

(8) Personnel having histories of skin or respirator ailments should be excluded from paint crews applying two component polyurethane or epoxy paints. When there is doubt, appropriate medical tests must be administered.

(9) Individuals who engage in mixing or applying plural component paints containing isocyanates will be subjected to appropriate pre-placement surveillance and periodic job related medical tests.

b. Fire Precautions. Most aircraft paints contain highly flammable constituents, which, under suitable conditions, can form explosive mixtures with air. As a result, the following precautions shall be taken:

(1) Electric motors used to drive exhaust fans or other equipment in storage places shall be of the type approved for explosive atmospheres. If such motors are not available, substitutes shall be located outside the room or building. Motor housing, fan frames, and the like shall be properly grounded to prevent possible static sparks, and all electric wiring shall be enclosed in conduits.

(2) All electric light bulbs used within storage area shall be enclosed in vaporproof globes, mounted in keyless sockets.

(3) Motor starting devices and switches in all electrical circuits, if not of the explosive-proof type and approved by an established electrical underwriter, shall be located outside room or building to prevent fire hazards from flammable vapors.

(4) Tools used to open containers shall be nonspark-producing types. All electrically-driven portable tools used in this area shall be explosion proof and properly grounded.

(5) Ample fire extinguishers of the foam, dry chemical, or carbon dioxide type will be provided.

WARNING

Containers of paint may develop internal pressure during storage and should be opened cautiously.

c. Opening of Containers. Paint containers may develop internal pressure due to storage at high temperatures or by development of gas due to deterioration. This condition may be detected by a bulging of light gage steel drums. Containers must be opened slowly to allow the pressure to escape before completely removing the seal.

NOTE

Failure to follow this procedure may result in paint being spattered on personnel and surrounding areas.

(1) Open containers, sealed with bungs, by slowly turning bung out until a hissing sound is heard. When hissing stops (an indication that pressure in and out of drum is equal) completely remove bung.

CAUTION

Use a fine, nonspark-producing tool and a soft-head hammer (rubber or plastic) to puncture drum.

(2) Containers which are bulged or distorted due to internal pressure shall have a small hole punctured in top to release pressure. After pressure is released, container may be opened in usual manner.

3-3. ATMOSPHERIC CONDITIONS FOR PAINTING.

a. Coatings normally should not be applied under unfavorable atmospheric conditions such as wind, strong drafts, dust, high humidity or extremes of temperature.

TM 55-1500-345-23

b. Specific guidance on ambient temperature and humidity ranges for painting with various coatings may be found in other parts of the TM, in the applicable specifications, or in the manufacturer's recommendations. If not specific guidance is given, the general guidance is to not paint below 50°F or above 90°F, nor below 40% or above 75% humidity.

c. The temperature of the surface to be painted must also be considered, and work schedules adjusted to allow or induce surface(s) to come to the proper temperature before applying paint.

3-4. SURFACE CONDITION. Prior to painting, inspect or test all metal surfaces for cleanliness and physical condition suitable for receiving paint material.

a. The water break test is a method of evaluating the degree of cleanness of a metal surface. It is based on the ability of a clean surface to sustain an unbroken film of water. Test representative areas of the surface to be painted by projecting distilled water on it using an atomizing device such as a nasal atomizer. Do not use a paint sprayer for this purpose as the excessive pressure will defeat this test. If water gathers into separate droplets within 25 seconds (that is, if the surface shows a water break) the surface has failed the cleanness test. If, on the other hand, the water suddenly flashes out into a film over a large area, an impurity such as alkali detergent, etc., is on the surface and it has failed the test. If the water merges into a continuous film without a sudden flashout, the surface has passed the water break test. A solvent wipedown is not required if the surface has passed a water break test.

b. Insufficient rinsing after cleaning may leave an unacceptable surface. For best adhesion of coatings, metallic surfaces should give either a neutral or a slightly

acid reaction when alkaline cleaners are used. Moistened red litmus paper when applied to the surface shall not react by turning blue. If such color changes occur, apply a 0.20 to 0.25 percent chromic acid -C-303 solution until a piece of blue litmus paper applied to the treated surface turns red, which indicates an acid surface. Permit the acid solution to remain on the surface from two to five minutes. Follow with a water rinse and then wipe dry with clean, lint-free cloths.

c. Determine whether the surface has appropriate surface treatment in accordance with TM 1-1500-344-23.

d. When a special solvent cleaning requirement exists in aircraft painting operations, use Military Specification, MIL-D-16791, TYPE 1, general purpose detergent, consisting of 1/2 ounce of detergent in a gallon of water for wipedown. Then wipedown the aircraft with isopropyl alcohol, TT-I-735. Additionally, each time the painting sequence of an aircraft is broken overnight or longer, this same procedure shall be performed immediately prior to application of further coats to insure cleanness and proper paintability of the surface.

e. Examine for presence of corrosion or foreign matter retained in seams and crevices, etc, and for oily films or deposits which may have accumulated after cleaning. If any of these are present, remove or treat as directed in TM 1-1500-344-23.

f. Assure that all metal surfaces and all seams and crevices are dry prior to application of paint. Pressurized filtered air may be used to dry these areas.

g. Non-metallic surfaces should be dry, free of contamination; all pores sealed and scuff sanded with an abrasive nylon mat in accordance with Military Specification MIL-A-9962.

3-4 Change 7

3-5. MATING SURFACES.

a. Application, Similar Metals. All seams in which the mating (faying) surfaces are similar metals will be protected by applying two coats of primer to each surface being joined. Welded faying surfaces shall not be primed prior to

assembly. Faying surfaces that are to be adhesively bonded will be surface treated and processed as specified in the approved bonding procedures prescribed for the assemblies concerned. In addition to the required primer coatings, faying surfaces of magnesium alloys will be filled with an approved sealing compound.

b. Application, Dissimilar Metals. Each surface to be joined will receive a minimum of two coats of the appropriate primer, and, in addition, the following precautions will be taken.

(1) Where magnesium is one of the metals of dissimilar metal faying surfaces, the metals will be separated by use of an approved barrier tape. The tape will extend not less than ¼ inch beyond the joint edges to prevent moisture from bridging between the dissimilar metals. Sealing compounds conforming to Military Specification MIL-S-81733 may be used as moisture barriers in lieu of tape and when used, the sealing compound will be applied between the surfaces and squeezed out of all boundaries and the excess removed in a manner that will fillet all edges. The fillet width will be not less than 1/4 inch. Joint areas which would retain water will be filled with a sealing compound conforming to Military Specification MIL-S-81733 or MIL-S-7124. When the use of a barrier tape or sealing compound is impractical because of mechanical or other factors, a primed 5356 aluminum alloy shim extending 1/4 inch will be used in lieu of the tape or sealing compound.

(2) Butt joints consisting of a riveted magnesium sheet and a riveted dissimilar metal sheet will be protected by grooving the seam to a width of not less than 1/8 inch and filling with sealing compound conforming with Military Specification MIL-S-81733. The depth of the groove will be sufficient to retain the sealing compound conforming to Military Specification MIL-S-81733, which will be subsequently applied and smoothed flush with the surfaces of adjacent dissimilar metals.

(3) Butt joints consisting of a magnesium sheet and a dissimilar metal sheet, either of which is secured by mechanical means other than riveting, will be protected by use of an approved adhesive barrier tape or a primed 5052 aluminum alloy foil which covers the cut ends of either or both dissimilar metal sheets and extends not less than ¼ inch beyond the joint edge.

(4) Organic adhesive barrier tapes or metal foils will not be used on exterior surfaces.

c. Attaching Parts. Parts, such as nuts, bushings, spacers, washers, rivets, high-shear rivets, screws, self-tapping screws, sleeves for "shakeproof" fastener studs, self-locking nuts, "speed nuts", clamps, and the like, do not need to be painted in detail except when dissimilar metals or wood contacts are involved in the materials being joined. Such parts will receive a coat of epoxy primer, MIL-P-23377 (wet or dry, at installation). Rivets (5066) in magnesium alloy need not be installed with epoxy primer. For magnesium dissimilar combinations follow the general requirements of paragraph 3-5. Close tolerance bolts passing through dissimilar metals will be coated before installation with a zinc chromate compound conforming to Federal Specification TT-P-1757, or a wet epoxy primer in accordance with Military Specification, MI L-P-23377. Aluminum alloy washers (5356) of suitable design will be used under machine screws, countersunk fasteners, boltheads, and nuts that would otherwise contact magnesium.

3-6. MASKING. Masking of specific areas is required in painting operations on large assemblies or structures either for protective reasons, as in the precautionary note below, or for purposes of delineation.

a. Mask areas such as windows, canopies and large openings with combinations of barrier materials.

(1) Federal Specification MI L-B-121, usually a treated paper which is oil and moisture resistant.

(2) Federal Specification MI L-B-131, usually a laminated foil and cloth or foil and paper with good water vapor resistance.

NOTE

Both types above are heat sealable.

(3) Crepe-backed paper masking tape, Military Specification MIL-T-21595, Type I.

b. Cover small or regularly shaped parts with tape alone.

c. In repetitive spraying of the same or similar structures, it is advisable to have available pre-designed bandages, socks, etc., of barrier paper or cloth.

d. Avoid using tape in such a way as to leave a paint edge on aerodynamic surfaces unless feathering by sanding can be done safely.

e. Use only approved masking tapes in varying widths required by the job. A complex or curved area is better masked initially at the paint edges with narrow (1/2 inch) tape. Wider tape may then be applied over the narrow, if required.

f. Use only approved masking paper for large area masking. Coating solvents may dissolve and deposit printing ink from newspapers, etc., on the surface of the area being masked; hence, such materials should be avoided as masking materials.

g. When spray painting, mask or cover surfaces at a distance from the area being painted which might receive over-spray or paint drift.

h. Masking tapes should be removed as soon as possible after coating application.

i. Press tape firmly at the masking edge when applying it to prevent paint bleeding under it by capillary action.

NOTE

Care should be taken to insure that paint is not applied to certain surfaces where paint will interfere with a function. The following should be masked or otherwise protected during painting: Machined surfaces that move with respect to each other such as threads, slip rods, bearing contacts and gear teeth; electrical parts, such as contacts, relays, insulators, sockets, plugs, connectors, wiring and terminals; plastic and rubber (natural and synthetic) mounts, spacers, etc, and lubrication fittings, cups, oil holes, etc. Do not paint interior of bomb racks or other actuators except as noted on manufacturer's drawing.

3-7. MIXING.

a. Painting materials shall be prepared for application under dry and clean conditions with dry and clean equipment.

b. Paint shops shall be equipped with continuous mechanical paint agitators of suitable capacity. The proper sequence for preparing packaged materials prior to each use is as follows:

(1) Allow materials to come to room temperature.

(2) Remove lids and inspect contents for skinover, gelling, lumps, etc. Skins, if present, shall be carefully removed and discarded, retaining liquids which drain from them. Gelled, lumpy or otherwise deteriorated paints shall not be used, but properly discarded.

NOTE

Cans of the pigmented component of MI L-C-46168 paint with non-resealable lids should not be opened and inspected until after the original mechanical agitation, if practical.

(3) Thoroughly agitate all component containers, using a mechanical agitator prior to mixing or thinning and again prior to and during application. Agitation must be continuous during application to assure uniformity of pigment.

c. Use automatic mixing and proportioning devices, if possible. When automatic equipment is not available, mix paint as follows:

(1) Breakup sediment remaining in original container with a clean wood or metal paddle; stir until a smooth, uniform, heavy paste forms.

(2) Proportion paint in clean mixing container to the four to one ratio specified. (This applies only to MIL-C-46168). Respirator must be worn.

(3) Catalytic action begins immediately on mixing. An eight hour pot life can be anticipated after mixing. Ideally, mixed paint should be used in six hours, to assure the capability for complete system purging and cleaning to precluded equipment damage.

(4) Assure complete mixing when manual mixing is used.

(5) To avoid the possibility of incompatibility of materials under the same specification but of different manufacturers, such materials shall not be mixed. Primers and topcoats from different manufacturers, under the same specification, will not be mixed, but may be applied separately to areas which are to be overcoated. Every effort shall be made, however, to assure that an entire topcoat is restricted to the product of a single manufacturer and, where possible, to the same batch in order to maintain uniformity of color, finish, etc.

(6) Application and mixing equipment must be thoroughly purged and cleaned after use.

CAUTION

Mixing should always be done in areas that are well ventilated and away from any source of open flame.

3-8. THINNING.

a. When thinning is necessary, always add thinner to the coating material. Adding coating material to thinner may result in an irreversible separation or degradation of some of the coating ingredients. Thinner should be added slowly with continual stirring to obtain complete mixing. For all thinning, use only thinners authorized in applicable instructions in this technical bulletin or pertinent specifications or, in the absence of these instructions, those recommended by the manufacturer. MEK can be used in cold weather. Other thinners may be needed in hot weather.

WARNING

METHYL ETHYL KETONE

- **Keep away from heat and open flame.**
- **Keep container closed.**

- **Use with adequate ventilation.**
- **Avoid prolonged breathing of vapors.**
- **Avoid prolonged or repeated contact with skin.**

Failure to observe these precautions can result in serious injury or systemic poisoning of personnel.

NOTE

The wrong thinner may destroy certain characteristics of a coating material without immediately giving visual evidence in the wet state.

Reduced material which has increased in viscosity due to evaporation will require corrective additions. However, some coating materials which undergo chemical processes, such as polymerization to create a film, cannot be thinned beyond a certain point and remain useable; nor can they be brought back to the correct viscosity by thinning after the chemical action has progressed beyond a critical point. This is the case with epoxy and polyurethane.

b. Thinning shall be controlled by weight, volume or viscosity measurement to obtain and maintain proper and uniform consistency. If there is no specification covering the material, thin according to manufacturer's instructions.

NOTE

Do not mix materials of the same specification but supplied by different manufacturers during application. This will avoid problems of incompatibility in the liquid and curing phases.

c. Strain all material to be used in spray equipment through clean 60-90 mesh metal strainers in accordance with paint or equipment manufacturers' instructions.

3-9. APPLICATION EQUIPMENT.

a. Application Systems. The application equipment plays a key role in the overall success of painting aircraft and aircraft components. Selection of application systems and care thereafter are essential considerations in the painting process, whether the system is an automated (robotics) or a manual type. No description or details are provided herein because of the wide variances

between equipment manufacturers and local conditions. Each manufacturer's instructions and other details must be consulted. Special consideration should be given equipment with which plural components are to be applied. Problems may be encountered, i.e., required accuracy of mixtures, pot life of mixtures and effects resulting from non-adherence to prescribed application procedures.

b. Components of Application Equipment.

(1) Automated Systems (Robots). Such systems include, but are not limited to, metering and mixing equipment, air compressors, air cleaners, electrostatic generators, spray booths, feed lines and tanks, regulators and computerized automated components.

(2) Hoses. Because of friction losses in hoses, it is essential that the proper sizes be used. Do not use hoses longer than 50 feet except in the case of high pressure air hoses leading to the regulator or tank. These may be a maximum of 150 feet for painting such areas as the tail surfaces of exceptionally large aircraft which are of considerable height above the ground. Extra lengths of hose may be attached for this use but should be removed when no longer needed. The high pressure air hose should have a minimum inside diameter of 7/16 inch. No less than 3/8 inch ID fluid hose should be used from the tank to the gun and no less than 5/16 ID air hose from the regulator to the tank and from the tank to the gun. Any reduction in size or increase in length from the forestated may produce unsatisfactory results. Air and paint hoses are furnished in various standard lengths, Determine the length required for use in a spray booth measuring the width of the booth and add two feet for the total required length of the hose.



Hoses should always be thoroughly cleaned by purging and flushing with solvent appropriate to the coating material used. When the material is a catalytic system (epoxy or polyurethane), this must be done immediately after use and before the prescribed pot life limit has been reached to prevent the material from gelling in the system.

(3) Associated Electrical Equipment. As required by manufacturers.

(4) Spray Guns, for Manual Applications. MI L-C-46168 paints shall be applied only in approved and qualified facilities. No application of MI L-C-46168 shall be accomplished in open air. In interior applications of MIL-C-46168 paint will be accomplished using personal respirator masks and equipment prescribed in Table 8-6.



Personal protective clothing, and disposition thereof, should also conform to OSHA and NIOSH safety specifications.

(5) Paint Booths and Application Equipment. No description or detail is provided for painting facilities due to the variance of equipment and local conditions. Such equipment must, however, conform to conditions of Tables 8-6 through 8-8. For automated robotic equipment, manufacturer's instructions should be consulted.

(6) Paint Brushes. Paint brushes should be used during touch-up procedures in open air when applying MI L-C-46168 paint. Consult section on touch-up procedures for details.

3-10. PAINT SPRAY GUN TECHNIQUES.

When manual spray applications are employed, techniques must be used which insure the most uniform and proper dry thin coating. Spray guns (and spray coatings) are designed to be used with certain spraying techniques. Quality of finish will depend on how well these techniques are used. Spraying techniques include the following:

a. Distance, Depending on the desired width of the spray pattern. the gun is held six to ten inches from the work (figure 3-1). If all other adjustments are correct. greater distance will result in dry spray or dusting and excessive over spray. Holding the gun too close to the work will result in coatings which are too heavy and will have a tendency to sag or run.

b. Stroking. The essence of proper stroking is maintaining the same distance of the gun from

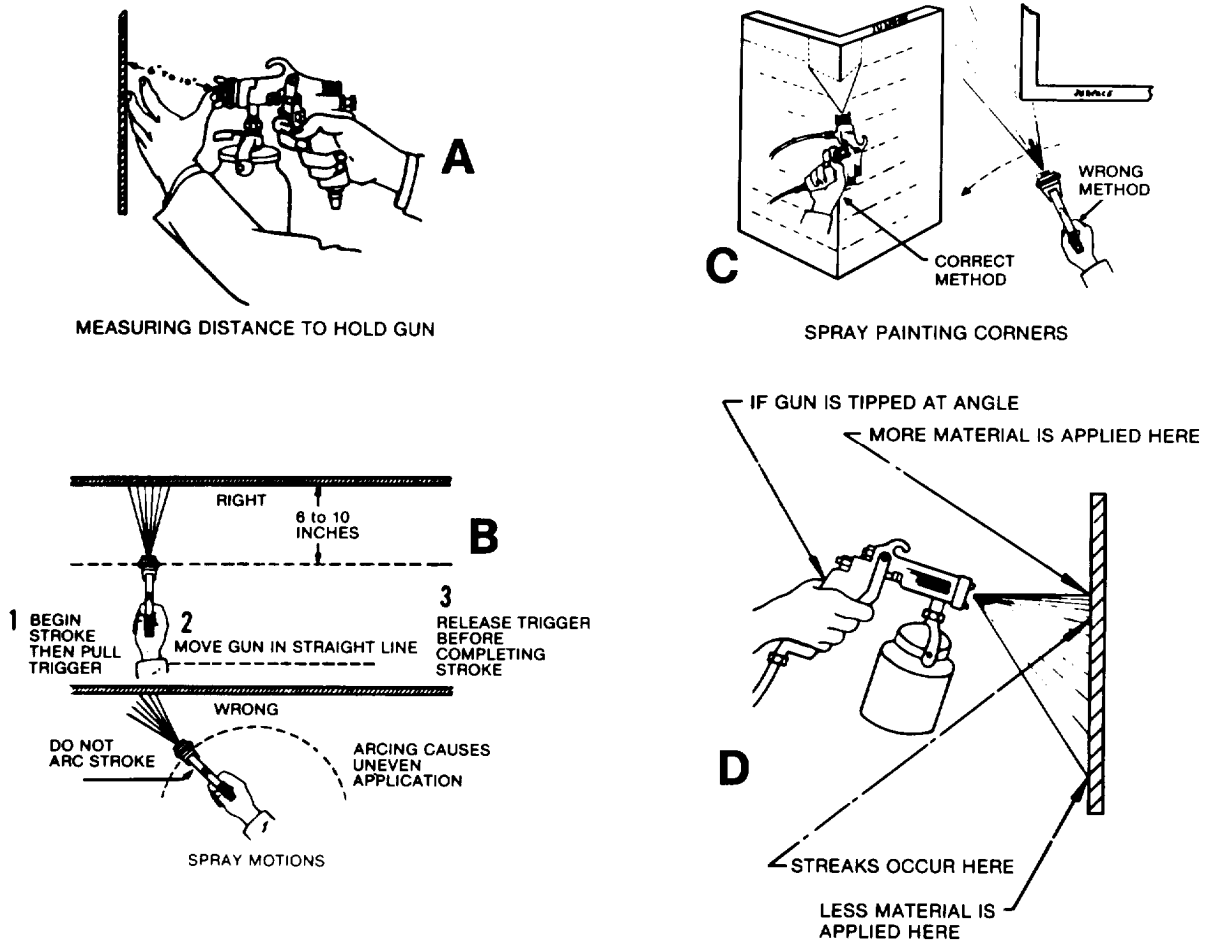
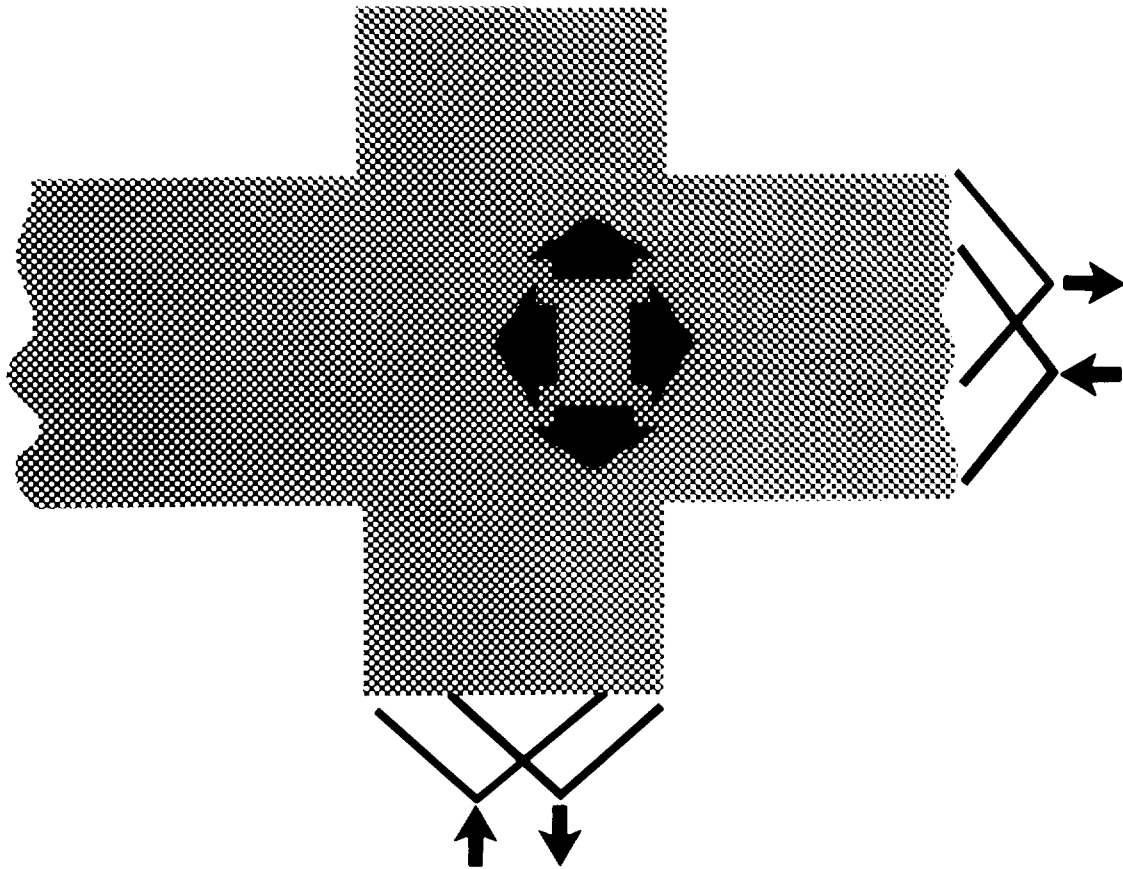


Figure 3-1, Right and Methods of Spraying

the work, the same speed, and as near to a right angle to the surface as possible throughout the entire pass. The natural tendency for spray painters, particularly when fatigued or in an uncomfortable position, is to arc or wave the gun (figure 3-1). This practice must be avoided at all costs. In general, wrist movement must be eliminated in stroking. A flexible wrist almost inevitably causes the gun to describe a curve instead of remaining parallel to the surface. This causes a thicker coating to be applied in the middle of the stroke than at the end. (An exception to the rules is in spotting during touchup. Here it is permissible to fan the gun to lay down a spot which is thinner at the edges in order to blend into the larger painted area.) Touch up here applies only to painting occurring in an approved facility and not open air touch up. Special pains must be taken, particularly when applying dense coating materials with

poor flow characteristics (such as MIL-C-46168), that the gun is held perpendicular to all surfaces (flat or contoured as they are passed).

If this is not done, the irregular spray pattern formed will lay down uneven thicknesses. Uneven thickness will cause uneven drying when using single component paint. Uneven thickness, when MI L-C-46168 paints are used may cause sagging. Protrusions such as screw heads, etc., present surfaces that will require facing the gun in several directions to completely coat them. It may be advisable to spot paint these in advance. The rate of the stroke should be uniform and such as to lay down a full wet coat of material. Stroking should be in parallel passes with each stroke aimed for a 50 percent overlay, or so that the middle of the spray strikes the wet bottom edge of the previous stroke (figure 3-3.)



HALF OF TOTAL COATS SHOULD BE CROSS-COATED

Figure 3-2. Cross-Coating

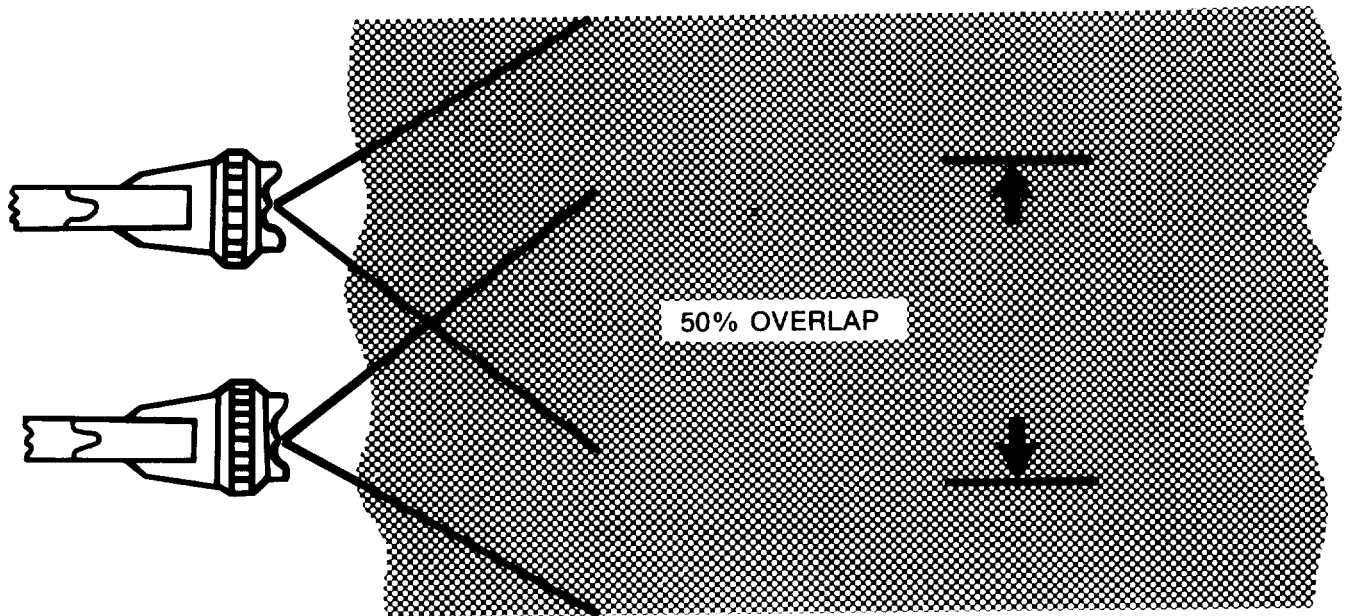


Figure 3-3. Fifty Percent Overlap

c. Triggering. Proper triggering of the gun is difficult to learn and can only be developed by practice. It is a matter of judgement and sensitivity of touch and variations of triggering technique may be called for in special situations. In general, the painter should begin his stroke before triggering the gun and release the trigger before stopping the stroke. It is intended to feather out the end of a stroke so that the end of a succeeding overlapping stroke will blend into it. Examples of correct techniques are shown in figure 3-1.

NOTE

A reasonable amount of care will maintain spray guns and spray equipment in top operating condition and prevent a majority of spraying difficulties. Thorough cleaning immediately after use and appropriate lubrication of equipment are essential. Care should be taken to not allow gelling to occur for any particular mixed batch of plural component paint. The system should be purged and flushed after use of each mixed batch to avoid system stoppages, and batch mixes.

d. Setting Spray Pattern. See Fig 3-4 for recommended adjustments.

3-11. PAINTING DIFFICULTIES AND REMEDIES.

a. Coating troubles may be divided into six groups: (1) Inadequate surface preparation (including temperature), (2) incorrect methods or techniques of application, (3) unusual and unsuitable climatic and atmospheric conditions, (4) unsuitable and improperly adjusted equipment, (5) faulty finishing material or improperly mixed or agitated components and (6) systems not purged of previously mixed materials. An experienced finisher may be capable of adjusting to obtain proper results with faulty materials, but this is an emergency measure only and must be with the cognizance and authority of the quality control facility. The practice is not advised. Incorrect methods of application should be discontinued upon discov-

ery of the discrepancy. Areas painted prior to the discovery of such discrepancies must be inspected and remedial measures taken when necessary. Brushing and roller coating on certain surfaces must be used in confined areas. Remedying incorrect applications, however, also calls for training. The practice of allowing inadequately trained personnel to apply MI L-C-46168 coatings, particularly to aeronautical surfaces, is unauthorized and dangerous. Unusual or unsuitable climatic and atmospheric conditions are normally not a problem since manual spray painting must be accomplished in an approved facility which usually compensates for such conditions. Unsuitable or faulty equipment can only be remedied by obtaining proper equipment or repair. Table 3-1 shows common troubles of spray coating operations with suggested remedies or methods of avoidance.

b. Faulty spray patterns and suggested corrections are shown in Fig 3-5.

c. Blushing of coatings is the result of water condensation from the atmosphere within, or on, an applied organic film. It occurs when the temperature of the work surface falls below the prevailing dewpoint. (It shall always be looked for in production coating whenever other than average atmospheric conditions prevail). It shows as a lighter-than-normal or bleached discoloration or increased opaqueness of the film. It may occur to the extent that a surface powder develops which can be removed by fingernail or by light rubbing. (Rubbing will not cure the condition). It may be almost imperceptible, and blushing inducing conditions may escape notice on test panels sprayed prior to production coating due to the temperature differences between test and production environment. Though MI L-C-46168 painted items are not susceptible to water or moisture damage immediately after proper application to items. Great care must be taken to avoid surface condensation prior to coating or water induction, in any form, into unmixed components or the mixture prior to or during application. Water will not affect the cure process after proper application. Water will affect paints other than plural component catalytic paints.

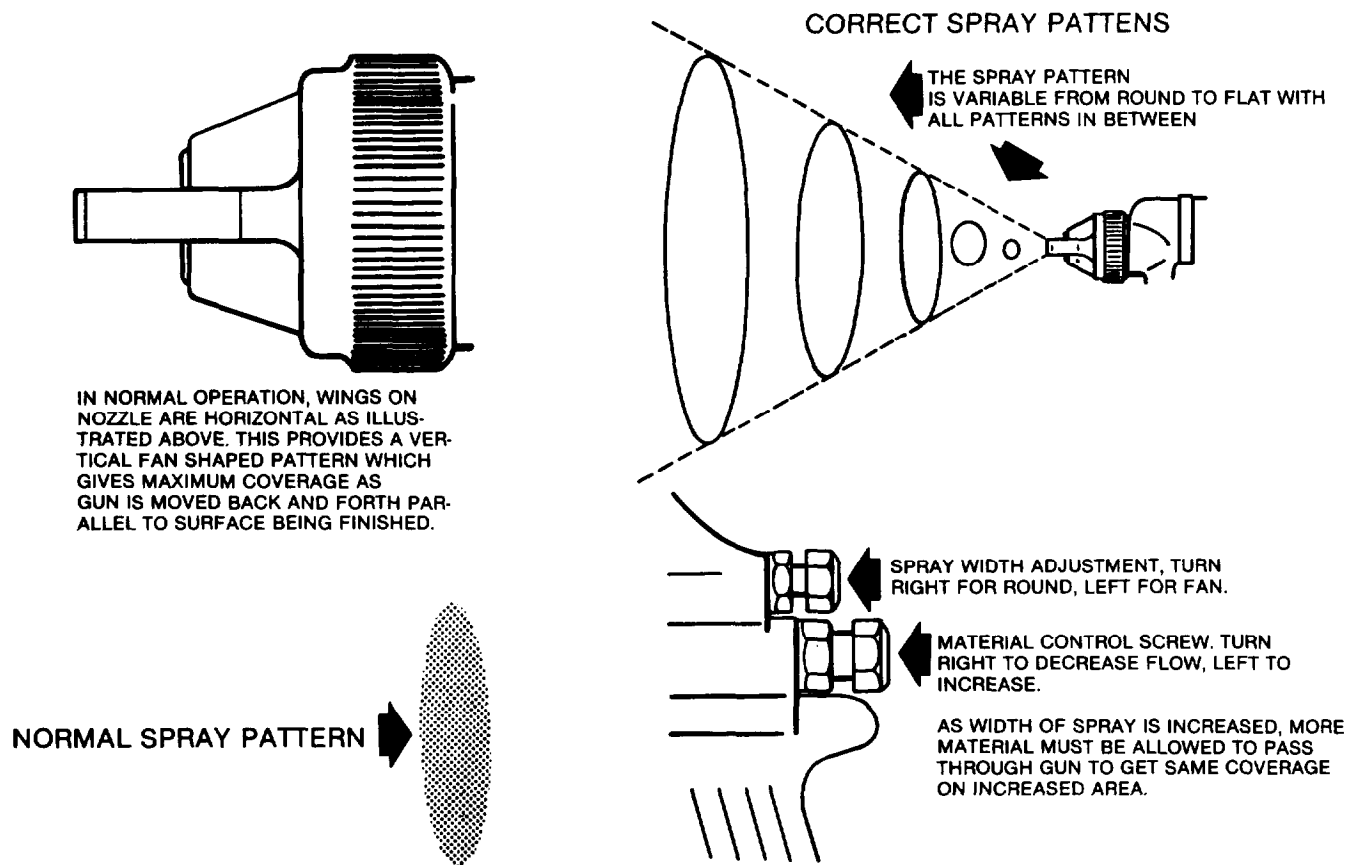


Figure 3-4. Setting Spray Pattern.

3-12. FILM THICKNESS (AIRCRAFT SURFACES).

a. Film applied either too thick or too thin will have reduced effectiveness in service. (See MIL-C-46168 for recommended film thickness applicable to standard coatings for aircraft. Recommended minimal dry film thickness is 1.8 mils). Attaining proper coating thickness by spraying is a matter of technique, plus periodically checking the work. There is a limit to the thickness that can be applied at one pass because of possible sagging of the film, and often this must be considered in obtaining the ultimate desired thickness of all paints. Also, there is a tendency with coating materials of good hiding power to increase the spreading rate as the work progresses and this

must be curbed. Changing atmospheric conditions, during operations, may have to be compensated for in order to continue applying a uniform film. Frequent checks with a wet film thickness gage, if available, should be made during painting to ascertain and control film thickness. Thickness cannot be gaged accurately without instruments, but, lacking these, the best assurance of consistent films is in correct initial adjustment of gun and material and the use of good judgement.

NOTE

Care should be taken that proper measurements are made when extremely rough texture paint is applied, e.g., MIL-C-46168 aircraft green.

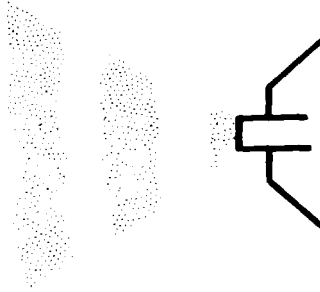
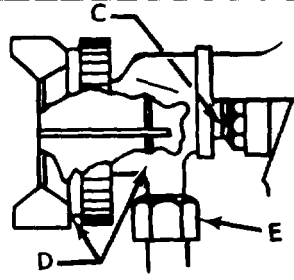
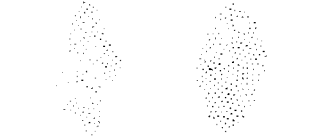
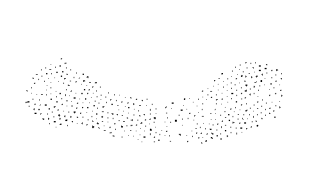
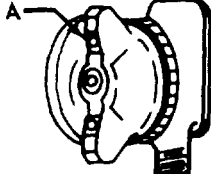
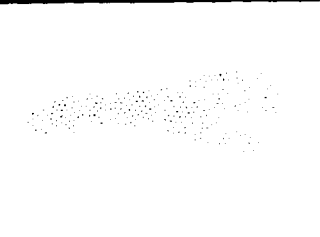
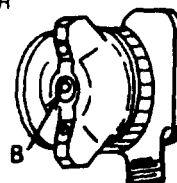
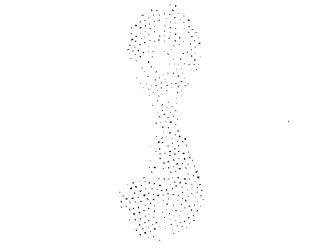
PATTERN	CAUSE	CORRECTION
	<p>(A) DRIED OUT PACKING AROUND MATERIAL NEEDLE VALVE PERMITS AIR TO GET INTO FLUID PASSAGEWAY. THIS RESULTS IN SPITTING.</p> <p>(B) DIRT BETWEEN FLUID NOZZLE SEAT AND BODY OR A LOOSELY INSTALLED FLUID NOZZLE WILL MAKE A GUN SPIT</p> <p>(C) A LOOSE OR DEFECTIVE SWIVEL NUT ON SIPHON CUP OR MATERIAL HOSE CAN CAUSE SPITTING.</p>	 <p>TO CORRECT CAUSE (A), BACK UP KNURLED NUT C, PLACE TWO DROPS OF MACHINE OIL ON PACKING, REPLACE NUT AND TIGHTEN WITH FINGERS ONLY. IN AGGRAVATED CASES, REPLACE PACKING.</p> <p>TO CORRECT CAUSE (B), REMOVE FLUID NOZZLE D, CLEAN BACK OF NOZZLE SEAT IN GUN BODY USING RAG WET WITH THINNER, REPLACE NOZZLE AND DRAW UP TIGHTLY AGAINST BODY.</p> <p>TO CORRECT CAUSE (C), TIGHTEN OR REPLACE SWIVEL NUT E.</p>
	<p>A FAN SPRAY PATTERN THAT IS HEAVY IN THE MIDDLE, OR A PATTERN THAT HAS AN UNATOMIZED "SALT-AND-PEPPER" EFFECT INDICATES THAT THE ATOMIZING AIR PRESSURE IS NOT SUFFICIENTLY HIGH.</p>	<p>INCREASE PRESSURE FROM YOUR AIR SUPPLY. CORRECT AIR PRESSURES ARE DISCUSSED ELSEWHERE IN THIS INSTRUCTION SHEET.</p>
	<p>DRIED MATERIAL IN WING PORT "A" RESTRICTS PASSAGE OF AIR THROUGH IT AND PRODUCES A CRESENT FULL PRESSURE OF AIR FROM CLEAN WING PORT FORCES PATTERN IN DIRECTION OF CLOGGED SIDE.</p> 	<p>DISSOLVE MATERIAL IN SIDE PORT WITH THINNER. DO NOT POKE IN ANY OF THE OPENINGS WITH METAL INSTRUMENTS.</p>
	<p>SPRAY PATTERN WIDER OR HEAVIER AT EITHER END IS CAUSED BY DRIED MATERIAL AROUND THE OUTSIDE OF THE FLUID NOZZLE TIP. B RESTRICTS THE PASSAGE OF ATOMIZING AIR AT ONE POINT THROUGH THE CENTER OPENING OF AIR NOZZLE AND RESULTS IN PATTERN SHOWN. THIS PATTERN CAN ALSO BE CAUSED BY LOOSE AIR NOZZLE.</p> 	<p>IF DRIED MATERIAL IS CAUSING THE TROUBLE, REMOVE AIR NOZZLE AND WIPE OFF FLUID TIP, USING RAG WET WITH THINNER. TIGHTEN AIR NOZZLE.</p>
	<p>A SPLIT SPRAY OR ONE THAT IS HEAVY ON EACH END OF A FAN PATTERN AND WEAK IN THE MIDDLE IS USUALLY CAUSED BY (A) TOO HIGH AN ATOMIZING AIR PRESSURE, OR (B) BY ATTEMPTING TO GE TOO WIDE A SPRAY WITH THIN MATERIAL.</p>	<p>REDUCING AIR PRESSURE WILL CORRECT CAUSE (A). TO CORRECT CAUSE (B), OPEN MATERIAL CONTROL TO FULL POSITION BY TURNING TO LEFT. AT THE SAME TIME TURN SPRAY WIDTH ADJUSTMENT TO RIGHT. THIS WILL REDUCE WIDTH OF SPRAY BUT WILL CORRECT SPLIT SPRAY PATTERN.</p>

Figure 3-5. Faulty Patterns and Suggested Corrections

b. Coating Thickness Measurements. Wet and dry film gages are available as local purchase items from various laboratory or paint supply houses. If paint film thickness measuring instruments are not available, small (5 x 16 inches) anodized aluminum test panels will be employed for the measurement of the paint thickness after drying. These panels will be applied to each side of the fuselage prior to the painting operation. One end of the panel should be masked with tape for a distance of approximately two inches to provide a comparison of the original panel system. Removal of the panel after application of the epoxy primer is recommended so that immediate touch-up operations can be employed to cover those areas previously protected by the panel. This procedure will also permit relocating of the panel on various portions of the same aircraft to provide a good indication of the overall paint thickness application. The location of the panel is dependent upon inspection procedures and may vary throughout the aircraft. Each aircraft should possess a panel for each operator employed on

the aircraft and it should be identified by the name of the operator, aircraft model, and the date of painting in order to provide follow-up data during any subsequent service evaluation. The panel is applied by the use of a small section of one-inch width masking tape doubled upon itself with the adhesive side contacting the panel and the aircraft surface. Slight errors in paint thickness measurement can exist due to thickness tolerances permitted by the basic aluminum procurement specification. This factor must be taken into consideration in the measurement of the thickness of the paint deposit. Measurement of the paint thickness is best accomplished by the use of an ordinary micrometer possessing flat contact surfaces when smooth textured paints are used. Micrometers possessing pointed or rounded contact surfaces are recommended when extremely rough textured paints are used. At least six readings should be taken on both painted and unpainted portions of each test panel to provide an average paint thickness measurement.

Section II. PRIMERS

3-13. GENERAL.

a. Use, General. Primers are used on metals to provide a coating to which subsequent coatings will firmly adhere and provide protection for the substrate metal against corrosion. The pigment portion of primers for ferrous base metals usually consists of iron oxide, chromate, red lead, zinc chromate, zinc oxide, zinc dust, or a mixture of these. Zinc olstrontium chromate is the pigment in some primers used on substrates of magnesium, aluminum and their alloys. Other primers

which are lead and chromate free are desirable for most applications and required in applications where lead and zinc chromate are prohibited.

b. Use, Aircraft. Primers are used as corrosion-inhibiting coatings on aircraft metal surfaces to inhibit corrosion and provide good adhesion for the topcoat. Primers will conform to Military Specification MIL-P-52192, MIL-P-23377 or MIL-P-85582.

3-14. PRIMERS.

a. MIL-P-23377 Primer. This is an epoxy polyamide primer furnished as a two- component kit wherein the two components are mixed prior to use. It is intended for application to clean aluminum and magnesium substrates. One component contains the pigment, mixed in an epoxy vehicle, while the other component consists of a clear polyamide solution which functions as a hardener for the epoxy resin. These components are packaged separately and have excellent storage stability. When mixed, storage life is eight hours. Only that amount which

can be used in an eight hour period should be mixed.

b. MIL-P-85582 Primer. This is a water reducible two component epoxy primer intended for use on non-ferrous alloys where volatile organic emission is a problem.

c. MIL-P-53030 Primer, This is a water reducible epoxy primer for use on ferrous alloys where volatile organic emission is a problem.

d. MIL-P-53022 is a lead and chromate free primer that may be used as an alternate to MIL-P-23377 on nonmetallic materials. ■

Section III. FINISH PAINTING: GENERAL

WARNING**METHYL ETHYL KETONE**

- Keep away from heat and open flame.
- Keep container closed.
- Use with adequate ventilation.
- Avoid prolonged breathing of vapors.
- Avoid prolonged or repeated contact with skin.

Failure to observe these precautions can result in serious injury or systemic poisoning of personnel.

3-15. MIL-C-46168. The Army standard tactical topcoat for aircraft is fully described in Chapter 4. Methyl ethyl ketone (MEK) can be used to differentiate between acrylic lacquer (MIL-C-46159) and polyurethane (MIL-C-46168) or epoxy MIL-C-22750 coatings. Put the coating with a cloth saturated with MEK. Acrylic lacquer coating will be dissolved but properly cured MIL-C-46168 coating will not.

3-16. MIL.-C-83286. GLOSS URETHANE.

a. Use. This aliphatic urethane finish is formulated for protection of areas exposed to chemicals and solvents and is intended for exterior or interior use on aircraft and other applications. It is a two component paint with a highly weather-resistant gloss finish used as a topcoat over epoxy primers, MIL-P-23377 and MIL-P-85582. It may be used in areas where air pollution regulations are in force. This finish is intended for use by exception only in accordance with the provisions of Chapter 5.

b. Top Coat (Mixing and Thinning). Consult MIL-C-83286 or paint manufacturer's instructions.

c. Application.

- (1) Clean per Chapter 2, Section I.
- (2) Strip old finish (if needed) per Chapter 2, Section II.
- (3) Apply metal conditioning per Chapter 2, Section III.
- (4) Apply primer per Chapter 3.
- (5) Apply paint per MIL-C-83286 or manufacturer's instructions.
- (6) Apply a full wet coat to dry film, thickness of 1.0 to 1.5 mils.

d. Touch-up of Polyurethane System. Closely inspect candidate areas for extent of damage and/or touch-up required. If inspection reveals major paint or primer failure or damage, such as chipped or peeled paint from the center of a skin panel, the involved skin section should be prepared and touched up from seam to seam. If only minor damage is found, e.g., paint chipped or missing from screw/rivet heads and on outer edges of skin panel(s) the specific area may be prepared and touched up. Prepare damaged area(s) and paint as follows:

- (1) Thoroughly clean area to be repainted.
- (2) Feather edges of coating adjacent to peel section and scuff sand the other area(s) to be coated. Use 280 grit paper or nylon abrasive matting, Military Specification MIL-A-9962, very fine for scuff sanding.

NOTE

(3) Solvent wipe scuffed area(s) with thinner, Military Specification MIL-T-19588.

(4) Apply one thin coat of epoxy primer, Military Specification MIL-P-23377 on area to be touched up.

(5) Apply one full wet coat of thoroughly mixed polyurethane topcoat. If required, apply a second coat after allowing 1 to 4 hours curing period for the first coat.

(6) Touch up shall be accomplished with brush and rollers only in open areas.

NOTE

This must be accomplished with full adherence to provisions of health and safety cited elsewhere and herein.

3-17. INSPECTION.

a. Waterbreak Test. See Paragraph 3-4.

b. Viscosity Test. See MIL-F-18264.

c. Test Panel. Prior to spraying operations, the suitability of materials for the entire system shall be determined experimentally on a panel approximately 10 to 32 inches in size. The panel shall be coated under prevailing conditions with the finish system that is to be applied. If the finish system applied to the experimental panel is satisfactory, full scale operations may begin. Defects found in the experimental application such as blushing, poor adhesion, excessive orange peel, sagging, etc, shall be corrected prior to large scale application.

d. Adhesion Test. See MIL-F-18264.

e. Gloss Test. (Not applicable to MIL-C-46168 paints). See MIL-F-18264.

f. Smoothness Test. See MIL-F-18264.

g. Film Thickness Test. See paragraph 3-12.

3-18. MIL-C-53039

a. MIL-C-53039 is a aliphatic polyurethane, single component, chemical agent resistant coating (CARC) used as a finish coat on tactical equipment. It is a moisture cured finish which is lead free and chromate (hexavalent) free, and has a maximum voc of 420 gm/1 (3.5 lbs/gallon) volatile organic compounds. This coating is applied over epoxy primers, MIL-P-53022, MIL-P-53030 or MIL-P-85582. It can be applied over a CARC base-coat which is thoroughly cleaned and is at least set

to touch or completely cured. It should not be applied over an existing alkyed or lacquer finish.

b. Top coat (mixing and thinning). Consult MIL-C-53039 or paint manufacturer's instruction.

c. Application.

(1) Clean per Chapter 2, Section I.

(2) Strip old finish (if needed) per Chapter 2, Section II.

(3) Apply metal conditioning per Chapter 2, Section III.

(4) Apply primer per Chapter 3.

(5) Apply paint per MIL-C-53039 or manufactures instructions.

d. Touch up of polyurethane system. If the old finish is in good condition, clean the surface with MIL-T-81772 thinner, to remove all contaminates such as grease, oil or fuel residue, and apply the topcoat. Areas sanded down to bare metal shall be pretreated, primed and then topcoated. Scratches or light damage to top coat will have to be scuff sanded at the damaged area. Prepare damage area and paint as follows:

(1) Clean area to be painted.

(2) Mask or tape the area to be repaired or touched up per Chapter 3, Section I.

(3) Scuff sanded area to be painted.

(4) Wipe down area to be painted with a clean rag wet with MIL-T-81772 thinner to remove loose sanding debris and fingerprints.

(5) Apply evenly one coat of epoxy primer over the area to be touched up. Allow epoxy primer to dry a minimum of 1 hour or until dry to touch before topcoating.

(6) Apply topcoat evenly to blend with the original surface around the area to be touched up. The total thickness or previous coating shall be checked prior to reworking. The coating thickness, existing plus rework, shall not exceed a dry film thickness of 1.8 mils. MIL-C-53039 will dry set to touch in approximately 15 minutes, dry hard in 90 minutes, dry through in four hours, with a complete cure in seven days. At 60° F (16° C), MIL-C-53039 requires twice as long to cure.

(7) Touch up shall be done in open areas when using brushes or rollers.

Table 3-1. Manual Spray Coating Troubles, Possible Causes, and Remedies

TROUBLE	POSSIBLE CAUSES	PREVENTIVE MEASURES OR REMEDIES
Sags and runs	<ol style="list-style-type: none"> 1. Dirty air cap and fluid tip (distorted spray pattern). 2. Gun stroked too close to the surface. 3. Trigger not released at end of stroke (when stroke does not go beyond object). 4. Gun stroked at wrong angle to surface. 5. Coating material too cold. 6. Coating piled on too heavy. 7. Coating material thinning too much. 8. Incomplete mixture of components. <p>NOTE Pot life must be considered when using plural component paint. Pot life is approximately 8 hours after mixing. Serious gelation occurs after 6 hours, at which point viscosity will impede the flow and ultimately completely stop the system. It is recommended that the system be flushed after 6 hours to preclude damage to the system.</p>	<ol style="list-style-type: none"> 1. Remove air cap and clean tip and air cap carefully. 2. Maintain 6 to 10 inches distance from surface. 3. Release the trigger after every stroke. 4. Keep gun at right angle (perpendicular) to surface during stroke. 5. Heat material by approved methods. 6. Develop ability to apply thicknesses by panel practice. 7. Add the correct amount of solvent by measure or determined by viscosity test. 6. Continuous agitation of mixture.
Streaks	<ol style="list-style-type: none"> 1. Dirty air cap and fluid tip (distorted spray pattern). 2. Insufficient or incorrect overlapping strokes. 3. Gun stroked too rapidly (dusting of the paint). 4. Gun stroked at wrong angle to surface. 5. Stroking too far from surface 6. Too much air pressure. 7. Split spray. 8. Coating material too cold. 	<ol style="list-style-type: none"> 1. Remove air cap and clean tip and air cap carefully. 2. Follow the previous stroke accurately. Deposit a wet coat. 3. Avoid whipping. Make deliberate, slow strokes. 4. Keep gun at right angle (perpendicular) to surface during stroke. 5. Maintain 6 to 10 inches from surface. 6. Use least air pressure necessary. 7. Clean the fluid tip and air cap. 8. Heat material to get good flow. out. (Use authorized heat methods).
Paint will not come from spray gun	<ol style="list-style-type: none"> 1. Out of paint (gun begins to sputter). 	<ol style="list-style-type: none"> 1. Add paint, correctly thinned out and strained.

Table 3-1. Manual Spray Coating Troubles. Possible Causes. and Remedies — (Continued)

TROUBLE	POSSIBLE CAUSES	PREVENTIVE MEASURES OR REMEDIES
Paint will not come from pressure tank	<ol style="list-style-type: none"> 1. Lack of proper air pressure in the pressure tank 2. Air intake opening inside of pressure tank lid, clogged by dried material. 3. Leaking gaskets on tank cover 	<ol style="list-style-type: none"> 1. Check for leaks or lack of air entry. 2. This is a common trouble. Clean the opening periodically 3. Replace with a new gasket.
Paint will not come from suction CUP	<ol style="list-style-type: none"> 1. Dirty fluid tip and air cap. 2. Clogged air vent on cup cover. 3. Using wrong air cap. 4. Leaky connections on fluid tube or nozzle. 	<ol style="list-style-type: none"> 1. Remove all air cap and clean tip and air cap carefully 2. Remove the obstruction. 3. Ascertain and use correct setup. 4. Check for leaks under water and repair.
Excessive material loss	<ol style="list-style-type: none"> 1. Not triggering the gun at each stroke. 2. Stroking at wrong angle to surface. 3. Stroking gun 100 far from the surface. 4. Wrong air cap or fluid tip. 5. Depositing a film of Irregular thickness. 6. Air pressure too high. 7. Fluid pressure too high. 8. Coating material too cold. 	<ol style="list-style-type: none"> 1. It should be a habit to release trigger after every stroke 2. Gun should be stroked at right angles to surface. 3. Stroke the gun 6 to 10 inches from the surface. 4. Ascertain and use correct setup. 5. Learn to calculate the depth of wet film of finish and develop control. 6. Use the least amount of air necessary. 7. Reduce pressure. If pressure keeps climbing, clean regulator on pressure tank. 8. Heat to enable reduced air pressure. (Use authorized heat methods)

Table 3-1. Manual Spray Coating Troubles. Possible Causes, and Remedies – (Continued)

TROUBLE	POSSIBLE CAUSES	PREVENTIVE MEASURES OR REMEDIES
<p>Failure of wet tape test</p>	<p>Insufficient drying time on wash primer and/or epoxy primer: Insufficiently cleaned surface: cleaning compound residue, etc. Oil seepage throughout inspection doors and blind rivets (especially jet aircraft) entrapped oils and soil in epoxy shop primer: excessively aged primer: insufficient removal of shop primer and/or previous coatings: use of final finishes incorporating wax ingredients: use of laundered rags instead of new mill ends: use of water-sensitive primer not conforming to specification requirements: seepage of water containing cleaning compound residues from between fraying surfaces.</p>	<p>Employ initial wipedown, using safety solvent followed by thinner as an auxiliary cleaner. Rinse with clear clean water when enzymatic cleaner is used: remove all shop primers to provide a clean surface prior to any coating: primer shop coat elimination preferred as O11 removal from shop primer coats practically impossible. employ solvent-dampened cloths in lieu of dry cloths for removal of oil contamination. Allow aircraft to stand for a sufficient time to permit drainage of effluent before final cleaning note the type of failure, such as to bare metal or intercoat failure, and select the applicable cause and remedy accordingly.</p>
<p>Lifting (figure 3-16)</p>	<ol style="list-style-type: none"> 1. Absorption of solvents by previous partially dried film. 2. Second coats apt 10 lift if poorly prepared surface. 	<ol style="list-style-type: none"> 1. Allow coat to dry before recoating. (Applicable only to single component paint.) 2. Begin with properly prepared surface 3. Use compatible coatings and thinners
<p>Pitting or cupping (figure 3-17)</p>	<ol style="list-style-type: none"> 1. Rust under surface. 2. Oil or grease on surface. 3. Moisture in lines. 4. Trapped solvents. <p>NOTE Do not mix materials and/or components of different manufacturers.</p>	<ol style="list-style-type: none"> 1. Drain lines periodically. 2. Use proper thinner proportions. 3. Strip and clean: or sand down and repaint
<p>Excessive spray fog (figure 3-6)</p>	<ol style="list-style-type: none"> 1. Too high air pressure. 2. Spraying past surface of the product. 3. Wrong air cap or fluid tip. 4. Gun stroked too far from the surface. 5. Material thinned too much. 	<ol style="list-style-type: none"> 1. Use least amount of air pressure necessary 2. Release trigger when gun passes target. 3. Ascertain and use correct setup 4. Stroke the gun 6 to 10 inches from surface 5. Add the correct amount of solvent by measure or test.
<p>Sandpaper finish (figure 3-10)</p>	<ol style="list-style-type: none"> 1. Unsatisfactory wash primer or primer. 2. Excessive dirt contamination from painting area. 3. Insufficient scuff-sanding of wash primer or primer. 4. Improperly cleaned paint lines. 	<ol style="list-style-type: none"> 1. Laboratory analysis to verify acceptability of the material: check wash primer and primer application procedures. 2. Provide cleaner painting areas. 3. Scuff-sand wash primer using No 320 and wet-or-dry abrasive, paper P-C-451. 4. Flush paint lines frequently with solvent.

Table 3-1. Manual Spray Coating Troubles. Possible Causes. and Remedies — (Continued)

TROUBLE	POSSIBLE CAUSES	PREVENTIVE MEASURES OR REMEDIES
<p>Paint will not come from spray gun</p>	<ol style="list-style-type: none"> 5 Dried overspray. 1 Settled, caked pigment or gelling paint blocking gun tip. 2 Grit, dirt, paint skins, etc. blocking gun lip, fluid valve or strainer. 	<ol style="list-style-type: none"> 5. Sand the complete finish until smooth to the fingertips. 1. Remove obstruction, stir paint thoroughly. 2. Clean spray gun thoroughly and strain the coating material. Always strain materials before using.

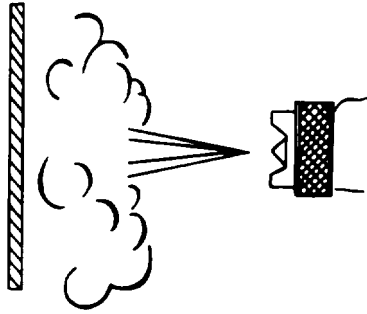


Figure 3-6. Excessive Spray Fog

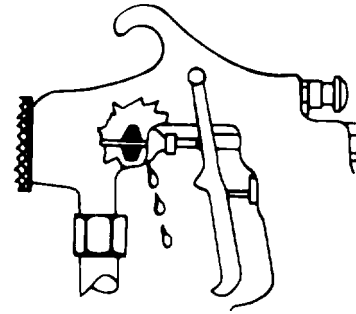


Figure 3-7. Paint Leaks From Spray Gun

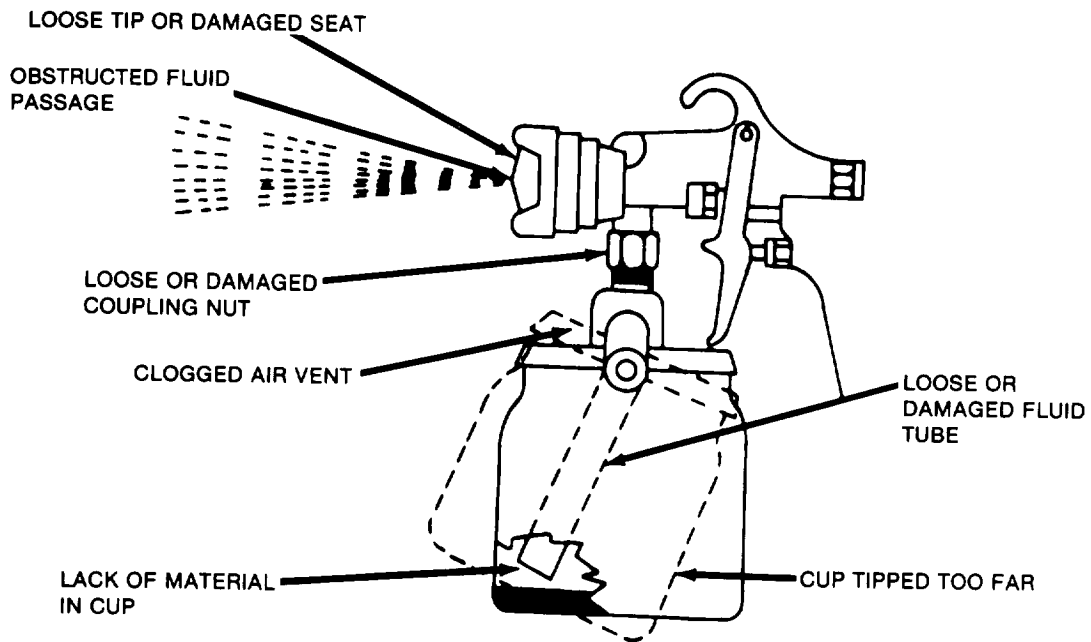


Figure 3-8. Gun Sputters Constantly



Figure 3-9. Orange Peel

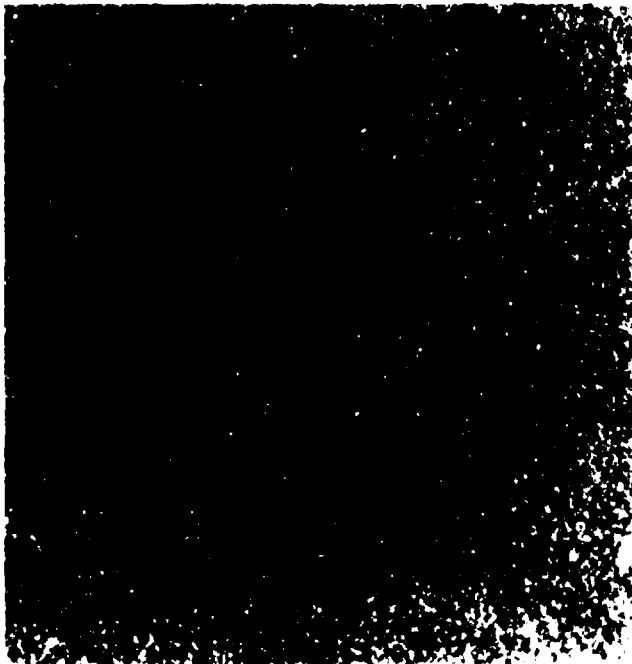


Figure 3-10. Sandpaper Finish



Figure 3-11. Wrinkling

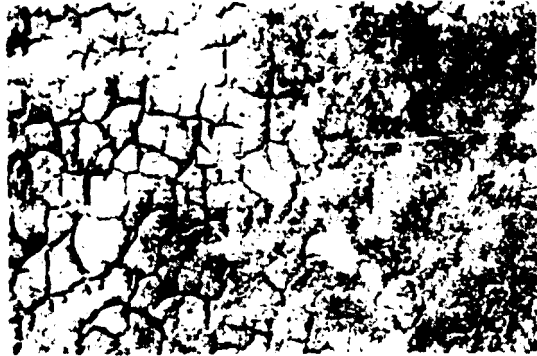


Figure 3-12. Crazing

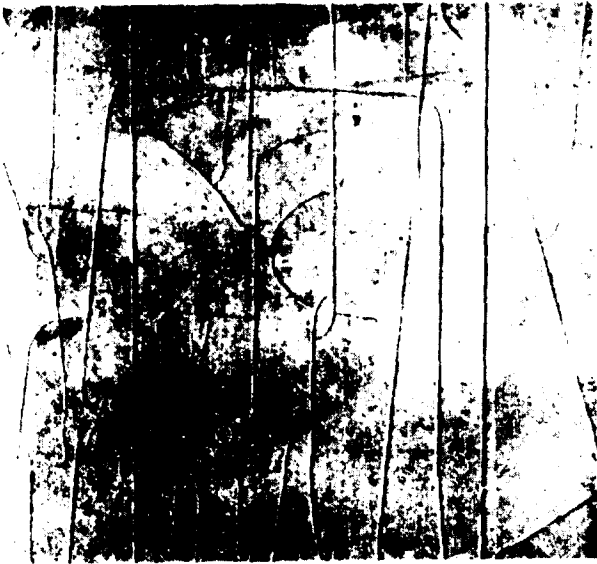


Figure 3-13. Checking

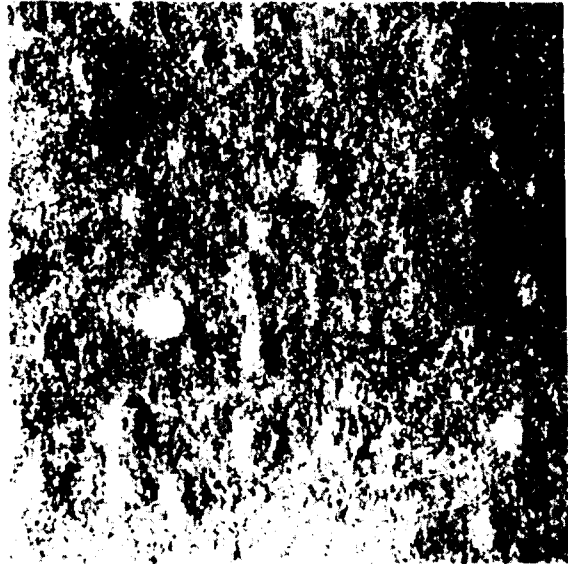


Figure 3-14. Blistering

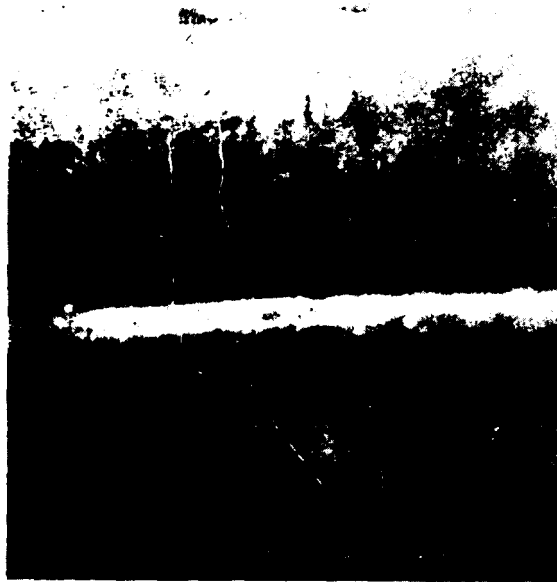


Figure 3-15. Fish-Eyes and Poor Wetting, Crawling, Poor Flowout

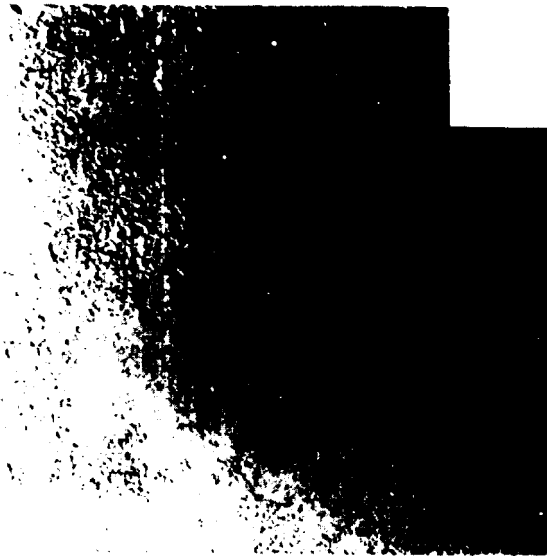


Figure 3.16. Lifting



Figure 3-17. Pitting or Cupping

3-19. TOUCH UP OF CONDUCTIVE COATING ON UH-60 COCKPIT DOOR.

The UH-60 cockpit doors are bonded assemblies made of Kevlar. The doors are coated with conductive coating, P/N 52-03-4914-000, for EMI shielding. Scratches or light damage to conductive coating will have to be scuff sanded at the damage area. Repair damaged area and paint as follows:

WARNING

Volatile and toxic fumes occur when using solvents, causing both a fire and a health hazard.

Provide proper ventilation and protective clothing, including eye shield, when using solvents. Avoid breathing vapors and skin contact as much as possible. Wash contacted skin with soap and water. If solvent contacts eyes, flush them with clean water and get immediate medical help.

CAUTION

To prevent damage to Kevlar laminate, do not allow solvents to contact exposed fibers. Do not allow solvents to remain in contact with Kevlar laminate.

a. Lightly sand damaged area using 280 grit abrasive cloth.

b. Wipe damaged area with solvent, MIL-T-81772 Type 3, to remove surface contamination.

c. Apply one coat of epoxy primer, MIL-P-23377. Allow primer to dry at least one hour to eight hours.

d. Conducting coating can be thinned to spray viscosity with thinner MIL-T-81772.

e. Apply three coats of conductive coating, P/N 52-03-4914-000, to make 0.003 to 0.004 inch thick coat. Allow 1/2 hour minimum drying time between coats.

f. After the last coat, the conductive coating shall be allowed to dry for one hour minimum.

g. Apply top coat evenly to blend with original surface around the area to be touched up. The top coat thickness shall not exceed a dry film thickness of 1.8 Mils.

h. Touch-up shall be done in open areas when using brushes or rollers.

CHAPTER 4

TACTICAL PAINT SCHEME

Section I. HELICOPTERS

4-1. GENERAL.

a. The coating system and painting scheme in this section is the Army standard for tactical helicopters. The finish coat provides a lusterless, low visibility and low reflectance surface in various military conditions.

b. This aircraft green topcoat conforms to MIL-C-46168. This topcoat is to be applied over primer conforming to MIL-P-23377 or MIL-P-85582. Advantages of MIL-C-46168 top coating are its properties of resistance to chemical agents, increased abrasion and impact resistance, improved exposure and weathering performance and superior longevity.

c. Aircraft green paint, MIL-C-46168, is rougher textured than most paints. This is intended, pursuant to achieving low reflectivity requirements.

4.2. EXTERNAL AREAS NOT TO BE PAINTED.

a. Areas Not to be Painted (General). Do not prime or apply any paint to any of the following exterior surfaces:

(1) Light lenses, windows, and windshields.

(2) Wires and cables (electrical).

(3) Areas containing slippage or tolerance marks unless the slippage or tolerance marks can be retained (1/2" masking tape may be used to cover marks).

(4) Rubber and cloth boots and dust covers.

(5) De-icing boots.

(6) Reinforced impregnated flexible ducting.

(7) Plastic or ceramic insulators for radio antennas.

(8) Rods that move in and out of hydraulic cylinders, on portions contacting a mating surface. Non-contact surfaces will be coated.

(9) Piston portion of landing gear struts and shimmy damper, where surfaces are mated.

(10) Interior and opening of pitot tube.

(11) Pitot static opening.

(12) Static ground receptacle.

(13) All bearings, races, and rod ends. Apply masking over, and 3/4 inch beyond, bearings, races, and rod ends. Masking will be snug and complete to prevent any spray from entering bearings, races, and rod ends.

(14) All hydraulic fittings. Apply masking to cover fittings and about one inch of tubes.

(15) Ambient air thermometer probe.

(16) Required conspicuity markings.

(17) Previously unpainted Aircraft Survivability Equipment.

b. Areas Not to be Painted (Specific). Do not prime or apply any paint to any of the following surfaces on OH-6 helicopters.

(1) Bolts, externally relieved (4 each per aircraft) located at the outboard end of each main rotor pitch housing.

(2) Pins, main rotor (4 each per aircraft) located at the inboard trailing edge of each main rotor blade.

(3) Pins, main rotor blade (8 each per aircraft) located at the root end of each main rotor blade.

4-3. PREPARATION OF MIL-C-46168 POLYURETHANE PAINT.

a. Polyurethane, MIL-C-46168 paint is a plural component, low reflective paint formulated to be lead and chromate free. The components of this paint must be thoroughly mixed prior to pouring into the application container when transfer is necessary. Care should be taken that all of the pigment matter has been included in the mixture.

b. Mixing and application equipment. Mixing requirements for the two component polyurethane paint, when applying by conventional air atomized or airless spray is to mix four parts of Component A, which is the polyester portion, to one part of Component B, which is the catalyst or isocyanate portion. After the two components are mixed, the total mixture is left to stand for at least 30 minutes to deaerate. The mixture (batch) is then thinned to the proper viscosity depending upon the spray equipment. The mix at the specified ratio will produce a pot life of eight hours. Therefore, no more paint should be mixed than can be used in an eight hour shift or period.

c. MIL-C-46168 paint must be thinned to spraying viscosity, determined by the user and the type of spraying equipment to be used. A suggested starting point is obtained by mixing approximately four volumes of mixed MIL-C-46168

paint and one volume of MIL-T-81772 thinner. The paint must be thoroughly mixed with the thinner and continuously agitated during application.

d. Where quantities permit, and to eliminate the 30 minute deaeration time and potential waste, plural component spray units can be used which automatically and proportionally mix the two components directly at the spray gun nozzle. Since the two components are kept separate, the pot life consideration is also eliminated.

e. The polyurethane paint can also be applied by conventional, airless, or electro-static spray equipment. In cases where this type of equipment is used, the viscosity can change. The applicator should check with the paint company and equipment supplied for the exact criteria for viscosity, thinning and the best application processes.

f. Whatever spray equipment is used, it is necessary that all spray guns, lines and nozzles, when applicable, be thoroughly cleaned after use to prevent hardening of the coating system. If the coating hardens in the system, the system cannot be cleaned. That portion of the unit in which the paint has gelled or hardened, must be discarded.

g. MIL-C-46168 paint may be applied over a wide range of temperatures. Temperatures from 50° F (24° C) to 90° F (32° C) are recommended for best results.

NOTE

MIL-C-46168 paint is a catalytic paint and will cure under most atmospheric conditions after application. However, at very low temperature, curing is retarded.

h. Test the mixture, pressure and spray equipment settings by applying a test coating to masking paper or similar smooth surfaces prior to application to aircraft or components. Adjust paint and/or equipment until proper test coating is achieved. Paint and equipment are then ready for application to aircraft or components.

4-4. PROCEDURES FOR APPLICATION OF MIL-C-46168 PAINT TO BARE METAL SUBSTRATES.

The total paint system for the polyurethane coating as with all other paint systems, requires cleaning, a pretreatment coating, an anticorrosive primer and the polyurethane topcoat. This applies to painting of bare metal substrates.

a. Cleaning. The substrate should be thoroughly cleaned of all oil, grease and other contaminants by appropriate methods cited elsewhere herein or as specified in TT-C-490.

b. Pretreatments. TT-C-490 finishing documents e.g., MIL-STD-186, MIL-T-704, etc., provide appropriate directions for surface preparation. For steel substrates, the pretreatments to use are zinc phosphate or wash primer conforming to DOD-P-15328. For aluminum, substrates, the pretreatment is alodine, MIL-C-5541.

c. Anticorrosive Primers. The anticorrosive primers to be used with the MIL-C-46168 paint system are the epoxy type. The epoxy primer to use with steel substrates is MIL-P-52192 and for aluminum and magnesium substrates is MIL-P-23377, or MIL-P-85582.

d. Topcoat. MIL-C-46168 coating is applied at 1.8 to 3.0 mils dry film thickness in two coats. The first should be applied in one to four hours of the application of the primer. The second coat may be applied within a few minutes of the first coat or anytime thereafter. The total thickness of the topcoat should not exceed 3.0 mils. There is no maximum time between application of the first and second coats, ideally within two hours. No surface preparation, except for cleaning, will be necessary as long as the surface has not become contaminated, e.g., with dirt or grease. MIL-C-46168 coating fully cures in 7 days.

Section II. FIXED WING AIRCRAFT

4-5. GENERAL. The tactical paint system is a three-coat system consisting of a chemical conversion coating applied to bare metal, followed by an intermediate primer coat, MIL-P-23377 or MIL-P-85582 and then finish-painted with a lusterless topcoat.

4-6. MATERIALS.

a. The chemical conversion coating will conform to MIL-C-5541 for aluminum and MIL-M-3171 for magnesium.

b. Intermediate primer will conform to Military Specification MIL-P-23377 or MIL-P-85582.

c. Aircraft gray paint will conform to Military Specification MIL-C-46168. For exceptions to aircraft gray, see Chapter 5.

4-7. PROCEDURE.

a. Clean and prepare aircraft surfaces for painting in accordance with Chapter 2.

b. Apply chemical conversion coating in accordance with manufacture's instructions.

c. Apply primer in accordance with the applicable specification.

d. Apply finish coats in accordance with instructions relating to application of MIL-C-46168 polyurethane coating.

Section III. MARKINGS

4-8. GENERAL. All markings, letterings, and numerals, including the identification lettering UNITED STATES ARMY, and radio call numbers, will be applied with Aircraft Black #37038 in compliance with instructions in

Chapters 7, 8, 9 and 10. As an alternate, black lusterless enamel may be used, overcoated with a clear polyurethane in accordance with MIL-C-46168.

Section IV. PROPELLER ASSEMBLIES AND BLADES

4-9. GENERAL. Details of the color scheme for propeller assemblies are in Chapter 6.

Section V. AIRCRAFT COMPONENTS

4.10. GENERAL. Aircraft components that are installed on an aircraft will be painted as follows:

a. New components shall be processed with MIL-P-23377 or MIL-P-85582 primer and painted with Interior Aircraft Gray #36231, per MIL-C-46168 or Aircraft Black #37038, per MIL-C-46168 (as indicated in paragraph 1-5b) or MIL-C-22750 of the same color.

b. Recycled components shall be oversprayed with a mist coat of MIL-P-23377 or MIL-P-85582 unless condition of primer indicates a necessity for stripping to bare metal.

at which time the item will be completely refinished. MIL-C-46168 or MIL-C-27750 paint shall be applied as the top coat.

c. Zinc chromate shall not be used as a primer, unless it is subsequently oversprayed with MIL-P-23377 or MIL-P-85582.

d. Previously painted surfaces of Aircraft Survivability Equipment will be painted. Caution shall be taken to avoid any coating of radiating or receiving surfaces or windows of this equipment.

Section VI. APPLICATION TO PREVIOUSLY PAINTED SURFACES (ROTARY AND FIXED WING)

4-11. GENERAL. MIL-C-46168 polyurethane paint must be applied over properly prepared subsurfaces. This paint shall not be applied over topcoats other than MIL-C-46168 painted equipment. Because of weight considerations, overcoating over MIL-C-46168 paint shall be restricted to small areas.

4-12. TOUCH UP AND REPAIR WITH MIL-C-46168. If there is not extensive damage to the paint and touch up is for cosmetic purposes

only or to cover up areas that are slightly marred or scratched, a supplemental polyurethane coating may be applied over the existing polyurethane finish. This must be done only on small areas and must be accomplished by brush application. No special surface preparation is necessary except for cleaning. If a small area is broken or damaged down to the substrate material, that area must be sanded, reprimed and topcoated. See paragraphs 4-3 and 4-4.

4-13. TOUCH UP AND REPAIR WITH MIL-L-46159. Aircraft which are totally painted with MIL-L-46159 paint must be touched up using MIL-L-46159. No special surface preparation is necessary except for cleaning. If a small area is broken or damaged down to the substrate material, that area must be sanded, reprimed and top-coated. The epoxy primer to use with steel substrates is MIL-P-52192 and for aluminum and magnesium substrates is MIL-P-23377 or MIL-P-85582. See Chapter 3, Section II, "Primers" for details on primer use and application. Extensive topcoat areas may be repaired by renewing the topcoat over existing primer if the primer is in good condition.

4-14. PREPARATION OF MIL-L-46159.

a. Low reflective paint. MIL-L-46159. must be thoroughly mixed in the original container prior to pouring into the paint application container.

NOTE

Paint application equipment must be clean prior to first use of MIL-L-46159. Halts of 5 minutes or longer duration during application will require flushing of the paint lines and spray gun to remove dried particles prior to restarting application.

b. Thoroughly mixed paint, MIL-L-46159, with appropriate thinner and retarder (as required) should be poured into the paint application container only in quantities required for use that day.

NOTE

IMMEDIATELY after adding paint and thinner/retarder, agitation should be started and operated for 1 to 3 hours prior to paint application. Paint agitation should be continuously maintained on liquids in the paint application container.

c. MIL-L-46159 must be thinned to spraying viscosity. A suggested starting point is obtained by mixing one volume of MIL-L-46159 with approximately one and one-half volumes of thinner composed of MIL-T-81772, Type III. The exact thinning ratio must be determined by the user and adjusted to the prevailing temperature and relative humidity. An acceptable alternate thinner consists of 2 parts by volume toluene (TT-T-548) and 1 part by volume xylene (ASTM D846). The exact ratio of thinner to paint must be determined by user and adjusted to the prevailing temperature and relative humidity.

d. MIL-L-46159 may be applied over a wide temperature range of 40° F (24 °C) to 90°F (32°C), and wide humidity range of 15 to 70%. High temperature and/or low humidity may result in dry spraying. High temperature and/or high humidity may result in blushing. To prevent these conditions and to provide a satisfactory finish, MIL-E-7125, Ethylene Glycol Monoethylether Acetate (cellosolve acetate or commercial equivalent such as Sherwin-Williams R7K206) may be required to first and second coat, and should be added. Add up to 30% acrylic retarder (MIL-E-7125 or commercial equivalent) as required, depending on temperature and humidity. (The higher the temperature and/or humidity, the more retarder required.)

e. Test the mixture, pressure and spray settings on masking paper or similar smooth surfaces prior to aircraft application to assure proper pigment dispersment. Large solids in test spray are indicative of dry spray and/or insufficient mixing. Add thinner, retarder and/or mix for a longer period of time, and retest as required to attain smoothest possible surface finish.

4-15. PROCEDURES FOR APPLICATION OVER PROPERLY PREPARED SURFACES.

a. Apply two coats of MIL-L-46159 lacquer to a dry film thickness of about 1.5 mils.

b. Apply first coat in continuous over-lapping strokes. Going back over partially dried areas will cause excessive surface roughness.

c. Allow first coat to air dry for approximately thirty minutes. Remove all dust and dry overspray by lightly wiping with a lint free cloth and blowing with clean air. Apply second coat as in b above. After two coats, film thickness should be approximately 1.5 mils.

d. MIL-L-46159 will dry sufficiently to be touched in approximately thirty minutes and will

dry sufficiently for flight in approximately four hours. Markings may be reapplied at any time after the paint is dried.

e. Do not reapply black paint to anti-glare areas because MIL-L-46159 is sufficiently dark to act as anti-glare. Application of heat resistant paint on the fuselage is not required.

f. When required, the low reflective paint and epoxy primer may be stripped by applying MIL-R-81294, remover, paint epoxy, and polyurethane systems.

CHAPTER 5

NON-TACTICAL PAINT SCHEMES

Section I. GENERAL

5-1. SCOPE. This chapter is limited to non-tactical paint schemes for specific geographic locations and missions other than tactical. Non-tactical paint schemes were developed to provide high visibility in congested areas, to enhance post-crash survival in hazardous terrain, or to identify a specific mission of an aircraft. The information in this chapter is provided to help the major Army field commanders, with authorized deviations, to select the appropriate paint scheme commensurate with the aircraft mission and location. In most cases, the standard tactical paint schemes in Chapter 4 are required.

5-2. AUTHORITY.

3. Major Army field commanders may apply for deviation for the standard tactical paint scheme depicted in Chapter 4 by writing to AVSCOM, ATTN: AMSAV-MEA, who has the authority to grant the deviations. Research and development aircraft which are the responsibility of project or systems managers are exempted from this requirement.

b. Authority to use unique non-tactical paint schemes, markings, insignia, etc. that are different from those described in this chapter, must be approved by the major Army field commander and deviation requests subsequently submitted to AVSCOM, ATTN: AMSAV-MEA, with complete justification (such as safety, mission requirement, cost reduction, etc.), and sketches or photographs describing the unique paint schemes. (See paragraph 1-4.)

5-3. WHEN TO PAINT NON-TACTICAL PAINT SCHEMES.

a. Aircraft in depot overhaul will be painted to a non-tactical paint scheme during overhaul if the major Army field commander, to whom the aircraft will be assigned, requests a specific non-tactical paint scheme, or if it is otherwise known that the aircraft will be definitely assigned to a mission or geographic location that requires a specific non-tactical paint scheme.

b. Newly-assigned aircraft that are known to have a limited length of assignment for a special non-tactical mission or location should not be repainted to a non-tactical paint scheme.

c. Assigned aircraft having the standard tactical paint scheme of Chapter 4 may be repainted to a non-tactical scheme when the long-range mission or location of the aircraft is such as to require a non-tactical scheme.

5-40 PAINT IDENTIFICATION. Where non-tactical paint schemes are authorized, the finish coat specified in the non-tactical paint schemes may be obtained by use of the polyurethane MIL-C-46168 or MIL-C-83286. See Chapter 3 for appropriate primers.

5-5. SHADE NUMBERS. The shade numbers of some colors of non-tactical finish coats are as follows:

■ Gloss olive drab	14084
Gloss white	17875

Gloss black	17038
Gloss red	11136
Gloss international orange	12197
Fluorescent red-orange	MILP-21600

5-6. FINISHING SYSTEM. The finishing or coating systems (sequence of paint starting from bare metal) for non-tactical paint systems are shown in Chapter 3.

Section II. SPECIFIC

5-7. ROTOR BLADES AND PROPELLER ASSEMBLIES. Paint schemes for rotor blades and propeller assemblies are covered in Chapter 6.

5-8. MARKINGS. Lettering, wording, insignia, etc. for non-tactical paint schemes shall be the same as for standard tactical aircraft unless specifically stated otherwise in this technical manual.

NOTE

Do not paint items currently unpainted, e.g., antenna masts, loops, antenna housing, radomes, exposed portions of operating mechanisms, transparent panels and anti-glare areas.

5-9. TRAINING AIRCRAFT.

a. TDA helicopters and fixed wing aircraft for training purposes may require additional vivid color schemes and markings to provide high conspicuity due to inexperienced student pilots flying in congested training areas.

b. The fuselage of the training aircraft will be the standard tactical paint schemes of Chapter 4. In addition, areas of fluorescent red-orange paint (MIL-P-21600), or tape may be used when required

and authorized. See Chapters 9 and 10 for figures showing details of high conspicuity markings for aircraft used for training.

c. The use of high conspicuity tape in place of fluorescent paint on flat or slightly curved aircraft surfaces offers a better marking for a longer period of time due to its durability, resistance to fading and quick turn around to the tactical configuration when necessary. Tests indicate that the tape does not fade in one year of use, whereas fluorescent paint tends to fade in about four months. Tape has limited application because it hides cracks and corrosion. Tape is to be applied only as shown in illustrations. To eliminate hidden corrosion, the tape shall not be applied over seams. Nonperforated tape shall not be applied over rivet heads, but perforated tape may be applied over rivet heads. Where necessary, the tape may be removed by the application of paint remover, MIL-R-81294.

d. TDA helicopters and fixed wing aircraft, used for training purposes, that are presently painted with international orange, in good condition, will not be refinished with fluorescent paint or tape. They will be maintained with international orange until complete repainting is required.

5-10. AIRCRAFT IN CONGESTED AREAS. TDA helicopters and fixed wing aircraft assigned to CONUS areas with high aircraft density may have the same high conspicuity paint schemes used for training aircraft, when approved as specified in paragraph 1-4.

5-11. AIRCRAFT FOR ARCTIC AND DESERT.

a. The paint scheme for tactical aircraft in arctic regions will be aircraft green unless otherwise designated by the major Army field commander.

b. If directed by the major Army field commander, TDA helicopters and fixed wing aircraft destined for arctic, or desert regions which have not been designated combat areas, may be painted all white, desert sand or with high conspicuity point schemes as described in Chapters 9 and 10.

c. In general, there will be a highly conspicuous band around the front and the rear of the fuselage. Vertical fins, horizontal stabilizers, and tips of wings on fixed wing aircraft will also have highly conspicuous areas or bands. Details for specific aircraft are shown in Chapters 9 and 10.

d. Highly conspicuous schemes will facilitate locating downed aircraft in the event of a forced or crash landing on ice, snow, or in desert areas. Highly conspicuous color schemes favor visibility in the arctic and desert.

e. To reduce peeling of paint in extremely cold locations (arctic, Alaska, etc.), the paint system should consist of alodine treatment, MIL-P-23377 epoxy primer, and appropriate urethane paints.

5-12. TEST SUPPORT AIRCRAFT. Aircraft utilized by White Sands Missile Range and other desert test or development activities. Test Support Aircraft category, may be painted in the high conspicuity arctic or desert paint scheme as described in Chapters 9 and 10.

5-13. MEDICAL RESEARCH AND GEODETIC AIRCRAFT. During peacetime, aircraft for these services may be painted with the high conspicuity arctic or desert paint scheme as described in Chapters 9 and 10.

5-14. GREENLAND ICECAP AIRCRAFT. Aircraft operating in the area of the Greenland ice cap may be painted entirely with international orange to ensure better inflight conspicuity and post-crash survivability.

5-15. MEDICAL SERVICE AIRCRAFT.

a. Army aircraft used as ambulance aircraft will be painted with the tactical paint scheme of Chapter 4, and will bear red cross insignia on a white field positioned on the most suitable surface to be visible from either side, from the ground and from the air. (See Chapter 9).

b. The crosses will be in aircraft Red, No. 31336, MIL-C-46168 and the field in aircraft White, No. 37875, MIL-C-46168. The overall dimension of the cross depends on available space. The width and length of each protrusion of the cross is one-third of the overall dimension, the white field will be square.

5-16. MILITARY ASSISTANCE PROGRAM AIRCRAFT. All aircraft assigned to the Military Assistance Program (MAP) will conform to the tactical paint scheme of Chapter 4 except that they will possess no insignia, US Army markings, or aircraft serial numbers. MAP aircraft will be identified by three metal tags, citing serial number, affixed in three conspicuous within the aircraft.

5-17. STAFF TRANSPORT (VIP) AIRCRAFT.

a. Fixed wing aircraft, which have been designated as staff transport aircraft are to be painted in accordance with the paint schemes shown in Chapter 10.

b. Staff transport aircraft being prepared for a combat area may be converted to the tactical paint scheme of Chapter 4, at the request of the major Army field commander.

5-18. RESEARCH AND DEVELOPMENT AIRCRAFT. The provisions of this manual will be used as required in determining the painting and markings to be applied to research and development air vehicles. The following markings are

considered mandatory for all research and development air vehicles: Identification lettering U.S. ARMY or ARMY, the national insignia, and the vehicle serial and model numbers, and conspicuity painting. Additional authorized markings will be applied as required. All research and development air vehicles will be conspicuously marked with the identification lettering U.S. ARMY or ARMY on all sides when exterior views of the item are photographed or when the item is on public display.

CHAPTER 6

FINISHES FOR SPECIFIC APPLICATIONS: GENERAL

SECTION I. GENERAL

6-1. AIRCRAFT FINISHES. This chapter shall present requirements for finishes for specific applications and applications not heretofore explicitly included.

a. All areas currently primed but unpainted will remain unpainted. Reprimed areas will use MIL-P-23377 or MIL-P-85582, e.g., under floorboards, inside tailbooms, and behind acoustical mats.

b. Acoustical mats, light curtains, cargo covers, troop seats and like materials will not be painted.

6-2. SURFACE PREPARATION. Surfaces will be prepared and primed as specified in Chapter 2, prior to application of any top coat.

6-3. APPLICATION.

a. Gloss finishes will be used as specified herein.

b. Polyurethane finish, MIL-C-46168, aircraft green will be used for all Army helicopters, except as excluded per paragraph 1-10.

6-4. COLORS. Colors will conform to Federal Standard No. 595 or the applicable military specification. Military Standard 795 is a supplementary document to the standard. Colors as Federal Standard 595 or MIL-STD-795 are designated by three digit numbers in the ANA bulletins and by five digit numbers in the Federal standard. Colors of paint compounds are identified by numerical coding system.

a. The first digit identifies the gloss of the color.

(1) The numeral one indicates gloss.

(2) The numeral two indicates semigloss.

(3) The numeral three indicates lusterless.

b. The second digit identifies the selected color classification group.

(1) The numeral one indicates red.

(2) The numeral two indicates orange.

(3) The numeral three indicates yellow.

(4) The numeral four indicates green.

(5) The numeral five indicates blue.

(6) The numeral six indicates gray.

(7) The numeral seven indicates white or black.

c. The last three digits identify the approximate order of increasing diffuse reflection.

6-5. DECALS. Stencils will be used in lieu of decals where possible. If it is absolutely necessary to use decals, they will be locally manufactured or obtained by alternative sources. Aircraft decals will not be stocked, stored or issued. Decals conforming to the requirements of Military Specification MIL-P-38477, plastic film for marking aircraft, may be used lieu of paint on gloss painted aircraft for external and internal markings within the size limits specified herein or as otherwise, stated in paragraph 7-2. Large, one piece decals are unsatisfactory because of application difficulties. Decals may be pressure sensitive, adhesive backed, and scored, but otherwise conforming to Military Specification MIL-P-38477. Pressure sensitive decals should be applied in accordance with TM 1-1500-204-23-1. Pressure sensitive decals are not recommended for use on MIL-C-46168 painted aircraft except where stencil lettering size is impractical.

Section II. PROPELLER ASSEMBLIES AND ROTOR BLADES

6-6. GENERAL

a. Purpose. The finish used on propellers and rotor blades is applied to prevent corrosion or deterioration of the underlying surfaces, to resist erosion from sand particles, dust, for anti-glare purposes, to decrease visibility of tactical aircraft used in some areas.

b. Paint Schemes and Shades. Paint schemes and shades for propeller assemblies and rotor blades are shown in Chapters 8, 9, and 10.

c. Tactical vs Non-Tactical Optimum High Visibility Schemes. Propeller assemblies and rotor blades of tactical aircraft in tactical areas or in normal CONUS areas shall be painted according to the standard tactical paint schemes. The non-tactical optimum high visibility paint schemes for propeller assemblies and rotor blades are permissible for TDA helicopters and fixed wing aircraft, as cited in paragraph 1-4. These schemes are to provide high visibility of propellers and rotor blades under the following conditions:

(1) High density aircraft on the ground to reduce the risk of personnel walking into propellers or tail rotor blades.

(2) High density aircraft in the air to reduce mid-air collision by making the aircraft below more visible.

(3) Visibility of downed aircraft in arctic, jungle or desert areas.

(4) Visibility of downed VIP aircraft.

(5) Visibility of aircraft in a training environment.

d. Requirement. Before selecting the optimum high visibility paint scheme, commanders should give consideration to the requirements for funds, painting and balancing equipment, and personnel to properly support the high visibility paint scheme.

e. Replacing Previous Schemes. Propellers and blades painted to previous non-tactical paint schemes need not be repainted to the optimum high visibility scheme unless repainting is needed for other reasons, such as excessive retouching or overhaul. TOE/MTOE helicopters which are painted with low reflective tactical paint schemes using MIL-C-46168, aircraft green. or aircraft grey, will not have the striped high visibility paint scheme applied to main or tail rotor blades. These aircraft will have blades painted in accordance with MIL-C-46168, aircraft black #37038.

f. Precedence. Concerning touch up, over painting, stripping, paint application and balancing; if the contents of this TM disagree with instructions in the aircraft maintenance manual or in overhaul manuals, the latter manuals take precedence over this TM.

g. Touch up. When necessary, propellers and blades may be lightly touched up between overhaul periods while installed on the aircraft. Care will be exercised to apply proportionate amounts of paint to each blade to maintain proper balance. Where touchup paint can be applied to all blades of an assembly in proportionate amounts, balance need not be accomplished. This is not to be interpreted as an authorization for deletion of propeller or blade balance at overhaul, or at any other time, when balancing is normally required.

h. Overpainting for Optimum High Visibility. The optimum high visibility non-tactical stripes in Chapters 8, 9 and 10 will not be added over the existing tactical paint scheme. Similarly, the tactical paint scheme will not be added over the high visibility paint scheme. The blades should be stripped, painted and rebalanced.

i. Stripping. Ensure all blade data and markings are obtained prior to stripping paint from blades so that the same data and markings may be restenciled on applicable blades subsequent to repainting. Propeller blades of fixed wing aircraft will not be stripped during aircraft repainting unless necessary.

WARNING

When rotor blades are bonded construction, the original finish should not be stripped because of possible harmful effects of paint strippers on bonding agents and adhesives. Personnel should consult applicable maintenance manuals for removal of old paint finishes from these blades.

j. Paint Application. When applying primer or finish coats, the blades and propellers must be in a horizontal position, and retained in that position until the paint or primer has set. Primer and finish coats should be sprayed on lightly and uniformly. Surfaces will be prepared and primed as specified in Chapter 2 unless otherwise directed. Topcoat finishing materials should conform to those materials listed herein.

k. Balancing. After complete repainting or extensive touch-up, the propellers and blades must be rebalanced in an intermediate maintenance or overhaul maintenance facility.

NOTE

CH-54 main and tail rotor blades shall be painted and balanced by the overhaul activity only.

AH-64 main and tail rotor blades complete repainting or extensive touch up should be accomplished at an approved overhaul facility because of balance requirements.

CAUTION

Painting of main rotor, tail rotor, and propeller blades may create out-of-balance and unacceptable vibration conditions. Strict adherence to instructions is required to reduce the probability of creating these out-of-balance conditions. Care must be exercised to apply proportionate amounts of paint to each blade to maintain proper balance.

NOTE

Complete repainting of main and tall rotor blades on UH-60 UH-1, OH-56 and AH-1 aircraft is normally accomplished during blade overhaul only. Main and tall rotor blades are individually balanced (spanwise and chordwise) to master blades during overhaul after painting to insure interchangeability between blades of the same configuration. Painting of blades in the field may cause subsequent interchangeability problems.

NOTE

Minor touch up is only needed.

l. Paint Procedures for Drive Shaft and Couplings. Polish out all surface defects with Scotch Brite (7447-B TYPE II) (26066). Touch up polished area with paint epoxy primer base 1-1G-69 (06367) and epoxy primer hardener 1-H-75 (06367) or a suitable substitute. First apply awash primer (MIL-C-8514 TYPE I) NSN 8030-01-015-6104. Allow to air dry for 1 hour.

6-7. PROPELLERS.

a. For tactical aircraft.

(1) Follow Chapters 9 and 10 on a specific aircraft if it contains details about painting blades, spinner or hubs.

(2) If sufficient data does not exist in Chapters 9 and 10, the standard tactical finish shall be Aircraft Black, MIL-C-46168, No. 37038, on both sides.

(3) The exterior surface of unplated hubs, fore and aft, will be painted with Aircraft Black, MIL-C-46168, No. 37038.

(4) On OV-1 aircraft blade data markings, propeller barrel, and dome assembly, markings shall be as follows:

(a) Paint an Orange-Yellow, No. 33538, blade angle checking station marking .0375 inch wide and 2.5 inches long at 42 inch station on the face side (opposite of direction of flight) of blades.

(b) The blade drawing number, serial number, low, feather, reverse and correction angles and the blade alignment reference (B. A. R.) value shall be stenciled on the camber side (direction of flight side) of the blade at mid-chord position. The letters used shall be 1/2 inch high and placed so as to be read from the trailing edge. The lettering shall start between the 18 and 24 inch stations. These markings shall be Orange-Yellow.

- b. For non-tactical aircraft.

(1) The blades may be painted with stripes per Figures 8-8, 8-9, 8-10, and 8-11.

(2) On all propellers, paint the stripes on the front side, and aircraft black on the backside. Plated hubs remain unpainted. Spinners to be painted as shown on figure 8-8 and figure 8-10. OV-1 blade data will be painted on nearest white section between 18 and 24 inch stations as described above. Data on blade on an aircraft, other than OV-1, may be placed on first white section from hub (spinner) and stenciled in aircraft black.

6-8. MAIN ROTOR BLADES.

NOTE

Complete repainting of rotor blades should be accomplished at an approved overhaul facility or depot activity. The weight and balance of blades is critical and complete repainting is not allowed by field units. Refer to applicable maintenance manual for extent of painting blades.

- a. For tactical aircraft. The upper and lower surface of main rotor blades shall be finished in Aircraft Black, MIL-C-46168, No. 37038.

- b. For non-tactical aircraft.

(1) The under surface of the blades shall be finished in aircraft black.

(2) The upper surface of the blades will be painted with stripes per figure 8-8, 8-10, and 8-13. Note that the outer two stripes are the same on all blades.

(3) For additional visibility in arctic areas, the outer 25% of the blades may be painted fluorescent red orange. The remaining portion of blades will be divided into 15% black and white segments as shown in the figures.

(4) The CH-54 shall not have the striped paint scheme because the size of this aircraft makes it visible without the striped paint scheme.

(5) The rotor and hubs and control mechanisms shall be painted aircraft black except for mating, load bearing or dynamic surfaces.

- c. Identifying dots of various colors will be installed by the contractor on mounted blades for the purpose of matching blade with identifying color on the hub. Blades ordered individually will not have identify-

ing dots installed by the contractor, but will be added by field personnel as required.

6-9. TAIL ROTOR BLADES.

NOTE

Complete repainting of rotor blades should be accomplished at an approved overhaul facility or depot activity. The weight and balance of blades is critical and complete repainting is not allowed by field units. Refer to applicable maintenance manual for extent of painting blades.

- a. For tactical aircraft.

(1) Prime blade surfaces epoxy type MIL-P-23377 or MIL-P-85582. Apply primer in accordance with Chapter 3.

(2) Both sides of the blades will be painted Aircraft Black, MIL-C-46168, No. 37038.

(3) The rotor hubs and control mechanism shall be painted aircraft black, except for mating, load bearing or dynamic surfaces.

- b. For non-tactical aircraft.

(1) Prime blade surfaces with primer MIL-P-23377 or MIL-P-85582. Apply primer in accordance with Chapter 3.

(2) Both sides of the blades may be painted with stripes per figure 8-8 and 8-13. Note that the outer two stripes are the same on all blades in figure 8-13.

(3) Application of stripes to tail rotor blades involves a 20% offset of non-concentric sections so as to provide concentric rings during rotation. Careful attention should be given to figures 8-8 and 8-13 when applying this paint scheme.

(4) The CH-54 tail rotor shall retain the stripes as indicated in Chapter 9, instead of the stripes in figure 8-13.

(5) The rotor hubs and control mechanism shaft be painted aircraft black, except for mating, load bearing or dynamic surface.

(6) For OH-6 aircraft, the high visibility paint scheme shall be applied only at facilities having proper balancing equipment for the OH-6 tail rotor blades. This special handling is required because of the critical balancing of the OH-6 tail rotor blades. Paint scheme may be changed at the time of tail rotor assembly overhaul.

Section III. AIRCRAFT EXTERIOR LANDING GEAR AND WHEELS

6-10. LANDING GEAR.

a. Helicopters. Helicopters skids and skid structures will be painted in the same manner as the fuselage, with aircraft green, MIL-C-46168. When repainting helicopters, the skids will be removed from the aircraft, the skid wells and enclosures will be inspected, cleaned and repainted. The removed skids will be inspected, cleaned or stripped, as appropriate, repainted and reinstalled on the aircraft.

b. Fixed Wing Aircraft. Landing gear of fixed wing aircraft will be processed in same paint as the fuselage. Mating, dynamic or load bearing sur-

faces, e.g., oleo pistons will not be painted. Landing gear of non-tactical aircraft will be painted color 17925, MIL-C-83286.

6-11. WHEELS.

a. Wheel wells of tactical aircraft will be painted Aircraft White, No. 37875, per MIL-C-46168.

b. During repainting, wheel wells will be thoroughly cleaned but not stripped.

Section IV. WALKWAY COATINGS

6-12. WALKWAYS. Walkway coatings conforming to Military Specification MIL-W-5044 will be applied on wing roots and heavy duty exterior traffic areas of all aircraft and overcoated with MIL-C-46168, aircraft green or aircraft black. Walkway coating conforming to Military Specification MIL-W-5044, Type II may be applied directly over any primed, enamel led or acrylic nitro-cellulose lacquer surfaces of the aircraft exterior. These areas must be overcoated with MIL-C-46168 aircraft green or aircraft black. The wing root walkways will be applied on both wing roots to a width of 18 inches measured from the fuselage and will extend from just aft of the leading edge to just forward of the trailing edge. The exact width may vary from the 18-inch requirement for specific aircraft. Safety walk, pressure sensitive material conforming to Military Specification MIL-D-17951, Type III, may be used as an option, but is not recommended. When such materials are used, they must be overcoated with MIL-C-46168 paints. Particular attention must be given the edges to assure good adhesion and sealing with MIL-C-46168 paint.

NOTE

Walkways on OV-1/RV-1 aircraft will be painted with MIL-W-5044, Type I, Class 1 Coating; these coatings will not be overcoated with MIL-C-46168.

a. Application Procedures for Walkway Coating, Military Specification MIL-W-5044.

(1) Apply walkway coating in accordance with application instructions in Military Specification MIL-W-5050.

(2) After each coat, allow a minimum drying time of 1/2 hour.

(3) After final coat, allow walkway coating to air-dry until set to touch before handling.

Table 6-1. Typical Aircraft Interior Areas To Be Painted (Sheet 1 of 3)

ITEM

AIRCRAFT

	AH-1	AH-64	CH-47	CH-54	OH-6	OH-58	OV-1	TH-55	UH-1	UH-60	
Metal framework, doors and windows	X	X	X	X	X	X	X	X	X	X	
Windshield frames	X	X	X	X	X	X	X	X	X	X	
Metal structure, walls and ceilings	X	X	X	X	X	X	X	X	X	X	
Glare shields, top and bottom and exposed operating accessories	X	X	X	X	X	X	X		X	X	
Instrument panels (metal structures)	X	X	X	X	X	X	X	X	X	X	
Frame of pedestals or consoles	X	X	X	X	X	X	X	X	X	X	
Seat frames, crewstations and cargo compartment	X	X	X	X	X	X	X	X	X	X	
Armor panels (omit rubber edging)	X	X			X				X	X	
Metal portions of control systems	X	X	X	X	X	X	X	X	X	X	
Crewstation handles, exit emergency	X	X	X	X	X	X	X		X	X	
Foot control arms, rudder pedals and support brackets	X	X	X	X	X	X	X	X	X	X	
Exposed metal parts of air vents (except swivel joints)		X		X	X		X		X	X	
Exposed metal parts of logbook holder	X	X	X	X	X	X	X	X	X	X	
Crewstation deck (including areas visible from chin bubble, where applicable)	X	X	X	X	X	X	X	X	X	X	
Cyclic control sticks and adjustment mechanisms	X	X	X	X	X	X		X	X	X	

* Other fixed wing aircraft currently have commercial interior paint schemes not applicable to this table.

Table 6-1. Typical Aircraft Interior Areas To Be Painted (Sheet 2 of 3)

ITEM	AIRCRAFT										
	AH-1	AH-64	CH-47	CH-54	OH-6	OH-58	OV-1	TH-55	UH-1	UH-60	*
Collective control system, except lock	x	x	x	x	x	x		x	x		
Ash trays	x	x	x	x	x	x	x		x	x	
Pedestal or console Panel (sides)	x	x	x	x	x	x	x	x	x	x	
Spare bulb holder (mask spare bulbs)	x	x	x	x	x	x	x	x	x	x	
Overhead consoles (sides and edges)			x	x		x	x		x	x	
Radio transmit foot switches(some masking required)	x	x	x	x	x	x		x	x	x	
Blanking plates on consoles or pedestals	x	x	x	x	x	x	x	x	x	x	
Crew and passenger stations	x	x	x	x	x	x	x	x	x	x	
Canopy egress system and explosive charge X covering (exposed Teflon cord must be masked with Scotch Cal tape prior to		x									
Restraining bands and brackets for fire extinguishers	x	x	x	x	x	x	x	x	x	x	
Framework supporting transilluminated panels (lift panels to paint frame)	x	x	x	x	x	x	x	x	x	x	
Hand holds		x					x		x	x	
Seats (adjusted to the most forward, all and vertical positions to assure full paint	x	x	x	x	x	x	x	x	x	x	
Seaf tracks, except sliding surfaces	x	x	x	x					x	x	
Collective pitch down lock (markings in Orange-Yellow No. 33538. after painting)			x	x	x				x		
Overhead console and switches (transilluminated). Touch-up, i.e., light scratches and crazing	x	x	x	x	x	x	x	x	x	x	x

Table 6-1. Typical Aircraft Interior Areas To Be Painted (Sheet 3 of 3)

ITEM

AIRCRAFT

	AH1	AH-64	CH-47	CH-54	OH-6	CH-58	OV-1	TH-55	UH-1	UH-60	.
Directional control pedal adjuster (all adjust knobs/levers, except plastic)	X	X	X	X	X	X		X	X	X	
External cargo mechanical release systems			X	X					X	X	
Fuel shut-off valve handle and guard					X	X		X			
Pilot's and copilot's directional and wheel brake pedals			X	X			X			X	
Inertial reels	X	X	X	X	X	X	X			X	
Hydraulic lines in chin bubble (mask identification tapes or replace)								X			
Avionics brackets in chin bubble									X	X	
Shoulder harness lock/unlock controls	X	X	X	X					X	X	
All accessory compartments accessible from outside	X	X	X	X	X	X	X		X	X	

Table 6-2. Typical Aircraft Interior Areas Not To Be Painted (Sheet 1 of 3)

ITEM	AIRCRAFT									
	AH-1	AH-64	CH-47	CH-54	OH-6	OH-58	OV-1	TH-55	UH-1	UH-60
Note: In general, the goal is not to paint those items that flex, issue instructions, or are transparent										
Windows and windshields (mask inside and out to avoid overpaint/ overspray and premature replacement)	X	X	X	X	X	X	X	X	X	X
Fire extinguishers	X	X	X	X	X	X	X	X	X	
Oxygen cylinders							X			
First aid kits	X	X	X	X	X	X	X	X	X	X
Restraint systems, including buckles (seat belts and shoulder harnesses should be removed to avoid overspray and premature replacement)	X	X	X	X	X	X	X	X	X	X
Seat cushions	X	X	X	X	X	X	X	X	X	X
Plastic material in seats	X	X	X	X	X	X	X	X	X	X
Instrument cases and glass (including magnetic compass and outside air temperature gage)	X	X	X	X	X	X	X	X	X	X
Rod end bearings			X	X	X	X		X	X	X
Electrical outlets			X	X	X	X		X	X	X
Emergency handles	X	X	X	X	X	X		X	X	X
All placards, markings, and data plates (yellow-orange stencils must be restenciled)	X	X	X	X	X	X	X	X	X	X

* Other fixed wing aircraft currently have commercial Interior paint schemes not applicable to this table.

Table 6-2. Typical Aircraft Interior Areas Not To Be Painted (Sheet 2 of 3)

ITEM

AIRCRAFT

	AH-1	AH-64	CH-47	CH-54	OH-6	OH-58	OV-1	TH-55	UH-1	UH-60	.
Flexible ducts made of fabric or rubber	x	x	x	x	x	x	x	x	x	x	
Soundproofing blankets fabric covered panels	x	x	x	x	x	x	x		x	x	
Key lock ignition switch (requires masking)	x	x	x	x	x	x	x	x	x	x	
Pedestal panel (top)							x				
DELETED											
Padded windshield wipers and/or rubber components									x		
All exposed wiring (except visible chin bubble wiring)	x	x	x	x	x	x	x	x	x	x	
Governor control switch on copilot's collective stick head	x	x	x	x	x	x		x	x	x	
Face of pilot's collective stick head	x	x	x	x	x	x		x	x	x	
Terminal boards	x	x	x	x	x	x	x	x	x	x	
Microphone control cords	x	x	x	x	x	x	x	x	x	x	
Cockpit utility lights	x	x	x	x	x	x	x	x	x	x	
External stores panel and jettison handle	x	x			x	x	x		x	x	
Compass switch	x	x	x	x	x	x	x	x	x	x	
Turret control panel	x	x									

Table 6-2. Typical Aircraft Interior Areas Not To Be Painted (Sheet 3 of 3)

ITEM	AIRCRAFT									
	AH-1	AH-64	CH-47	CH-54	OH-6	OH-58	OV-1	TH-55	UH-1	UH-60
Calibrated ADF loop antenna control	X	X	X	X	X	X	X		X	X
Armament system sighting units	X	X								
Caution panels	X	X	X	X	X	X	X	X	X	X
All information and radio panels	X	X	X	X	X	X	X	X	X	X
Static pressure lines	X	X	X	X	X	X	X	X	X	
Pilot's and copilot's control stick handles							X			
Pilot's and copilot's thrust control rod end bearings					X	X				
Boots around control rods	X	X	X	X	X	X	X	X	X	X
Hydraulic lines and fittings	X	X	X	X	X	X	X	X	X	
Station 95 bulkhead			X							
Collective pitch down locks (where painted yellow)		X	X	X	X	X		X	X	
Console panel (top)	X	X	X	X	X	X	X	X	X	X
Pilot's and copilot's cyclic control handles	X	X	X	X	X	X		X	X	X
Pilot's and copilot's collective control rod end bearings	X	X	X	X	X	X		X	X	X

NOTE

Full hardness is attained within maximum drying time of 24 hours.

(4) After walkway coating is completely dry, sand all edges to fair in with adjacent finished area. Walkways will not be polished or waxed.

(5) Apply MIL-C-46168 paint over entire compound and over edges.

6-13. ANTIGLARE COATINGS. To reduce glare, the top of the fuselage in front of the pilot's compartment on aircraft is illustrated in Chapter 10 and the inboard upper one-fourth of the engine nacelles forward of the leading edges of the wings on the U-8, and the inboard and outboard nacelles of the OV-1 will be painted aircraft black. Helicopters painted with tactical paint schemes do not require antiglare paint forward of windshield.

6-14. BATTERY COMPARTMENTS.

a. Neutralization

(1) Acid Electrolyte. Exercise care to prevent acid from spreading to adjacent areas. Wash areas affected by battery acid with 20 percent solution of sodium bicarbonate, Federal Specification O-S-576, in water. Neutralization is completed when bubbling ceases. After neutralization, remove all traces of sodium bicarbonate solution with generous quantities of water to prevent corrosion.

(2) Alkaline Electrolyte. Exercise caution to prevent acid from spreading to adjacent areas. Wash areas affected by electrolyte with 3 percent solution of boric acid in water. Neutralization is

completed when bubbling ceases. After neutralization, remove all traces of boric acid solution with generous quantities of water.

b. Treatment After Neutralization. Treat affected area by swabbing with 5 percent solution of chromic acid, Federal Specification O-C-303, or 5 percent of potassium bichromate, Federal Specification O-P-559, followed by flushing with water and thorough drying.

c. Painting. After the above neutralization and treatment, apply the following paint system:

(1) Apply two (2) coats of epoxy polyamide primer, MIL-P-23377, Type I or Primer, MIL-P-85582.

(2) Apply (over these coats) one (1) coat of primer coating epoxy, MIL-P-52192.

NOTE

Coating (1), MIL-P-23377, is yellow. When wear, scratching, or other topcoat damage occurs, the yellow or gray primer undercoats will be exposed indicating that repainting is necessary. This is essential to protect aluminum or magnesium composite structures.

d. Touchup. Using organizations may touch up the battery areas after proper neutralization.

(1) Acid Battery. One coat acid-proof varnish TT-V-51.

(2) Alkaline Battery. One coat MIL-C-83231, Type II coating.

6-15. HIGH TEMPERATURE AREAS.

a. Below 400° F (204° C).

(1) Surfaces exposed to exhaust gases, corrosive fluids, environmental elements, and areas known to be subject to corrosive attacks for which ambient temperatures do not exceed 350°F (177°C), finish in accordance with (2) through (3) below.

(2) Apply two coats of MIL-C-46168 paint. in appropriate color, over one coat of epoxy primer, MIL-P-23377 or primer MIL-P-85582.

(3) Areas and components fabricated of magnesium or steel. other than corrosion resistant steel. that are exposed to temperatures exceeding 300°F (149°C). but not above 400°F (204°C), either on the ground or in flight (other than momentarily). finish with MIL-C-46168 in appropriate color. Use primer. MIL-P-52192. where ferrous metals are involved.

b. Above 400° F (204 °C).

(1) Coat aluminum alloy surfaces with heat resistant paint, military specification MIL-P-14105 Color Shade No. 34087 for Olive Drab and TT-P-28, Color Shade No. 17178, for aluminum.

(2) On areas and components fabricated of magnesium or steel. other than corrosion resistant steel, that are exposed to temperatures. from 400° F to 500° F (204° C to 260° C). use silicone finish systems applied directly on the chemical surface-treated metal. omitting the wash prime and primer. Unless authorized by the government procuring activity. the color will conform to the color scheme for the aircraft. Above 500° F (260° C) use heat-resistant finishes as approved in each instance by the government procuring activity.

(3) Deleted

c. Deleted

NOTE

These are modified silicone paints which require heating to 450° F (232° C) for an hour after application. However, when applied to turbine engine surfaces, the heat generated in normal operation is considered adequate for curing. Cured silicone paints will resist the attack of diester oils.

6-16. RUBBER. Do not paint rubber components, either natural or synthetic.

6-17. ANTENNAS AND RADOMES.

a. If aircraft are painted without removing antennas and radomes, thoroughly mask the antennas and radomes.

b. Use the applicable TM 11 series manual for guidance on painting antennas.

c. On fixed wing aircraft, finish leading edges of antennas and radomes exposed to the airstream with rain-erosion-resistant system conforming to Military Specification MIL-C-83231 or MIL-C-83445 (See 6-33).

d. Radomes are not to be stripped or painted.

Section V. INTERIOR PAINTING

6-18. GENERAL.

a. General Information for Painting Crew-stations.

(1) All tactical rotary wing aircraft crew-stations shall be painted Aircraft Black, No. 37038, per MIL-C-46168. Tactical fixed wing aircraft shall be painted lusterless gray, per MIL-C-8779. Interior marking stencils shall be Aircraft White, No. 37875, MIL-C-46168. When decals are used, they shall be white vinyl ink letters on a lusterless black background.

WARNING

Paint residue can retard free movement of flight and power controls causing unsafe conditions leading to a crash. Therefore, check all flight and power controls before flights following painting of aircraft interiors. Emergency handles should also be checked for freedom of action.

(2) See Table 6-1 for items to be painted. See Table 6-2 for items not to be painted.

(3) See Chapter 7 for general interior lettering and marking instructions.

(4) Uninhabited enclosures in the crew-station area will also be painted Aircraft Black No. 37038 (e.g., map holders, under console and circuit breaker panels and equipment storage areas).

(5) Crewstations and passenger stations of OH-6 and OH-58 aircraft will be painted Aircraft Black, No. 37038, per MIL-C-46168. Passenger compartments of fixed wing aircraft will be painted lusterless gray or green per MIL-C-8779. Markings and stenciling applied in passenger stations of these aircraft will be in Aircraft White, No. 37875, MIL-C-46168. Decals shall be white vinyl ink letters on a lusterless black background.

NOTE

Do not spray paint transilluminated console panels.

(6) Transilluminated console panels with crazing, scratches and gouges may be touched-up with lusterless black lacquer. Touch-up may be accomplished by using a small bristled brush, wetted with MIL-L-19538 or MIL-L-46159, black #37038, lacquer.

b. Cargo/Troop Compartments.

(1) The aircraft cargo/troop compartments will be painted either in polyurethane, MIL-C-46168, or epoxy paint, MIL-C-22750. Epoxy paint has characteristics equal to those of polyurethane in applications not continuously exposed to sunlight.

(2) Aircraft cargo/troop compartments will be painted in Interior Aircraft Gray No. 36231, MIL-C-46168.

(3) UH-1 aircraft cockpit and troop compartments will be painted aircraft black, No. 37038, MIL-C-46168. Except the UH-1 Aircraft assigned to aera medical evacuation units will retain aircraft gray, No. 36231, MIL-C-46168 in the cargo/troop compartment and aircraft black in the cockpit.

(4) Markings and stencils applied on the gray of cargo/troop compartments will be in aircraft black, No. 37038, per MIL-C-46168. Markings applied on aircraft black will be in aircraft white, No. 37875, MIL-C-46168.

(5) Uninhabited enclosures and/or bays of cargo/troop compartments will be painted in the same manner as the compartment, e.g., avionics compartments, hydraulic components, areas under acoustical mats.

c. External access and equipment bays and enclosures will be painted in aircraft black with markings and stencils in Orange-Yellow, No. 33538, MIL-C-46168.

6-19. MIL-C-46168, AIRCRAFT BLACK, No. 37038, POLYURETHANE PAINT, CREWSTATION SURFACES.

a. The MIL-C-46168 topcoat is a plural component low reflective polyurethane paint system, intended for use over epoxy polyamide primer, MIL-P-23377 or MIL-P-85582.

b. This coating system and paint scheme constitute the Army standard interior crewstation paint system for tactical aircraft. The system provides a non-specular chemical resistant surface for aircraft crewstations. This paint system also enhances crewstation compatibility with electro-optical assisting devices and reduces the exterior electro-optical signature.

c. Field crewstation touch-up procedures will include brush and roller processes only.

CAUTION

Spray equipment for touching up interior crewstation surfaces is not to be used, except by overhaul, manufacturer or other facilities qualified to appropriate safety procedures.

d. Maximum effectiveness of lighting and chemical/biological resistance is achieved when as much of the aircraft crewstation is coated as possible. It is particularly important that surfaces which are touched or handled be properly maintained in this paint system.

6-20. EPOXY PAINT, MIL-G22750, FOR INTERIOR SURFACES OTHER THAN CREWSTATIONS.

a. This is a plural component paint which has chemical agent resistance equal to MIL-C-46168 paints. It is formulated for interior surfaces which are not continuously exposed to sunlight.

b. MIL-C-22750 paint is applied in two coats. Apply a mist coat and air dry for 15 minutes. The second coat should be applied until the total dry film thickness is 1.7 to 2.3 mils. The total thickness of the topcoat should not exceed 2.3 mils.

c. MIL-C-22750 may be used to refinish internally installed components, see paragraph 5-1.

d. This paint may be used in cargo/troop compartments or uninhabited areas in lieu of MIL-C-46168. It should be painted in either gray or black.

6-21 MIL-C-46168, POLYURETHANE, INTERIOR AIRCRAFT GRAY, No. 36231.

This is a plural component polyurethane coating paint, intended for use over epoxy polyamide primer, MIL-P-23377, or MIL-P-85582.

6-22. PROCEDURES.

a. These procedures will be implemented by maintenance personnel who have the proper training and equipment to apply epoxy primers and plural component polyurethane paints.

(1) It is essential that all painting and

cleaning be performed according to safety procedures described in this TM. Occupational Safety and Health Administration (OSHA) and National Institute of Safety and Health (NIOSH) requirements. Prior to operations, the painting facility and processes must be approved by the local safety office.

(2) It is imperative that crewstations be well ventilated during all painting operations, and proper respiratory equipment be used.

(3) Extreme care must be exercised to prevent any paint or solvents from coming in contact with restraint belts or the belts may be damaged and require replacement due to loss of tensile strength.

(4) There are four possible methods of applying MIL-C-46168 paint to crewstation areas.

(a) Apply paint with spray equipment, after appropriate masking, during manufacturing and production or aircraft overhaul only.

(b) Use of paint brushes or rollers at field level applications and maintenance.

(c) Dismantle assemblies, spray the parts in an appropriate facility and reassemble, as required.

(d) Combinations of the above.

(5) The choice of the proper method depends on the model of aircraft, the facilities and trained manpower available at the location to do the painting, the quantity of aircraft to be painted, condition of the existing coatings, and the specific areas to be painted. Any method or combination of methods may be used with adherence to proper safety procedures.

b. Evaluate the existing coating to determine if the aircraft crewstation is in a condition to receive the MIL-C-46168 coating, or if the existing coating must be stripped. If existing coatings are not acceptable, process in accordance with Chapter 2, Surface Preparation.

c. Aircraft crewstations painted with MIL-L-46159 or MIL-C-46168 interior aircraft black are rough textured and are not acceptable surfaces. These surfaces must be stripped to the primer surface and reprocessed when a complete repainting is performed. (For touch up of areas previously painted with MIL-L-46159, see 4-13.) Where primer is worn through to the metal substrate, such areas must be treated as metal substrate areas and processed in accordance with provisions herein for such areas.

d. Cabin areas of some UH-60A aircraft have a topcoat of TT-L-20, Gray No. 36231, that should be maintained and touched up as required with the TT-L-20 (camouflage lacquer) until these aircraft are converted to an interior topcoat of MIL-C-46168.

e. Mask all cabin areas that may be damaged by paint, paint vapors and cleaning solvents. See paragraph 6-26 for areas and items to be painted. This is particularly important for acrylic surfaces such as canopies and panels.

f. Primers required. Acceptable surfaces require only a flash coat of epoxy primer to insure maximum adhesion of MIL-C-46168 paint. The flash primer coat may be eliminated if the area to be painted is extremely small and the surfaces are acceptable according to paragraph 4-12 and are appropriately cleaned prior to topcoating. Primers may be applied with brushes or rollers,

(1) Apply a full primer coat on all areas where there is expected heavy abrasion wear (cabin decks, pedals, foot rests, etc.)

(2) It is necessary to reprocess all bare metal areas.

(3) Using the basic application procedure described in Chapter 3, apply MIL-P-23377 or MIL-P-85582 Primers. Apply 0.6 to 0.9 mil to surfaces to be overcoated.

Allow the primer to dry one to two hours. Under some environmental conditions, shorter drying times may be allowable and preferred.

NOTE

As the drying time of epoxy primer increases beyond two hours, the adhesion of the top coat may decrease considerably. Care must be exercised to observe the maximum primer drying time. When the time limit is exceeded, a mist coat of primer must be applied to the surface prior to topcoating.

6-23. APPLICATION.

a. The amount of MIL-C-46168, Aircraft Black, No. 37038 paint will be mixed which will be used during the subsequent 6-8 hours. The thoroughly mixed components A and B will be allowed to set for a period of 30 minutes for aeration. This aeration period is not necessary if spray equipment is to be used.



Spray equipment will be used only in crewstations and similar confined areas when proper ventilation and protective equipment is used.

b. Subsequent to the aeration period the paint will be stirred frequently to assure suspension of solid particles and uniform surface application.

c. The mixture will be thinned in accordance with Chapter 4. The exact thinning ratio and viscosity will be determined by the user and the application method.

6-24. APPLICATION WITH SPRAY EQUIPMENT.

a. Assure facility and equipment adequacy.

b. Apply paint, after application of primer, where required. Allowing the appropriate drying period, apply first coat in continuous overlapping strokes. See Chapter 4 for additional instructions.

c. Allow first coat to set at least ten minutes before application of second coat in continuous overlapping strokes to achieve the required dry film thickness of 1.8 - 3 mils.

NOTE

Continuous or frequent agitation of the mixture must be maintained to assure suspension of solid matter and uniformity of topcoating.

d. The cured topcoating shall show no running, sagging, streaking or other surface inconsistencies.

e. Interior stencils and markings may be applied any time subsequent to ten minutes after application of final topcoat.

f. No heating or drying apparatus is required since this paint is catalytic and will cure under most ambient conditions. Full use cure will occur in 18-24 hours.

6-25. APPLICATION WITH BRUSH OR ROLLERS. See Chapter 4.

6-26. TYPICAL AIRCRAFT INTERIOR AREAS TO BE PAINTED. Refer to Table 6-1.

6-27. TYPICAL AIRCRAFT INTERIOR AREAS NOT TO BE PAINTED. Refer to Table 6-2.

6-28. DECALS, PLACARDS, MARKINGS, LABELING IN COCKPIT AREA (WHEN USED).

a. General. Present decals, placards, markings and labeling in the cockpit area of some helicopters may cause reflections which interfere with night flight. The following actions are necessary to subdue the markings and take full advantage of the low reflective black paint in the cockpit area.

b. Type Size. It is preferable to use a lettering font in accordance with MIL-HDBK-759 and a width

to height ratio of 1 to 8 to optimize readability under very low illumination levels.

c. Wire Bundles. For tactical aircraft, cover all exposed electric wire bundles with MIL-I-15126, black tape to reduce reflections from light colored wires.

d. Remove the following from helicopter cockpit areas:

(1) Radio Magnetic Indicator Placard on CH-47

(2) DC Electric Instrument Placard Label on turn and Slip Indicators.

(3) Instrument Panel Checklist.

(4) Radio Call Designator/Aircraft Identification Placard. Replace with new placard containing the words RADIO CALL in letters 3/16 inch high, and aircraft identification numerals 5/16 inch high. Use lusterless Aircraft White #37875 letters and numbers on an aircraft black placard.

(5) Map Case Marking and Junction Box on UH-1. Remove all markings except HI VOLTAGE on map case or junction box, if map case is removed.

(6) Compass Correction Card, RMI and Magnetic. Place information in the front of the aircraft log book where it can be referred to easily.

NOTE

It is permissible to locally manufacture a metal insert painted lusterless black for installation in the front of the compass card holder during night flight.

(7) Communication/Navigation Control Box Identification Labels on UH-1, AH-1 and OH-58. These labels identify the location of the control boxes in the console. Remove these labels from the side of the center console.

(8) Cargo Caution Decal on UH-1.

(9) Airframe Overhaul Facility or Quality Control Identification Decals. Remove these decals from the crewstation area and reposition them to another location inside of the aircraft. The decals should be located so that they will not be easily rubbed or subjected to unnecessary weathering. They should be readable during daylight conditions.

(10) Engine Caution Decal on UH-1.

(11) Stabilizer Engine Decal on UH-1.

(12) Crashworthy Fuel System Installed Decal.

(13) Operating Limits Decal on UH-1, AH-1 and OH-58.

(14) Engine installation Decal on UH-1.

(15) GO-NO-GO Take-off Data Placard. Place TEAC maximum N1, RPM% and data entries in the front of the aircraft log book where it can be referred to easily.

(16) Minimum Crew Weight Placard on UH-1 and AH-1.

(17) Environmental Control Unit Limit Decal on AH-1

(18) XM-28 Warning Hydraulic Pressure Low Decal on AH-1.

(19) Warning Decal for use of Engine Condition levers Below 17° C on CH-47C.

(20) Radio Transmitter Select Identification Placard.

e. Redundant labels of Instrument on UH-1, and OH-58. Several instruments on the UH-1, AH-1 and OH-58 have their function displayed on the instrument and also on a placard or label on the panel adjacent to the particular instrument. Remove all duplicate labeling from the instrument panel. Judgement must be exercised before removing these labels. For example, on the UH-1, there are two temperature displays having the same dial face, but one is used for the engine and the other is used for the transmissions; both panel labels for these two instruments shall remain. The gas producer display, on the other hand, has duplicate labeling on the instrument and on the instrument panel: the panel label should be removed.

f. VNE Computer on CH-47. Do not make any change to this computer.

g. Marking General. Any placards, decals, markings, or labeling not discussed above shall be retained but modified if necessary to have lusterless Aircraft White #37875 lettering/markings on a low reflective black background.

h. Placard Material. Placards may be made of L-P-387A plastic sheet, laminated, type NDP, 1/6 inch thick, opaque, dull black face with white core; or equivalent.

i. Adhesives. Before applying decals, placards, tape or labels, lightly sand the paint in the area of application, Adhesive EC847 may be used for placards.

j. Touch-up. If the instrument panel was already painted with black before receipt of this TM, remove and/or replace markings, placards, labels, etc., according to the instructions in para 4-5. Touch up the panel.

k. Removal of Decals, Labels, etc. To remove decals, labels, etc. follow TM-I -1500-204-23-1, or use a razor blade.

6-29. EMERGENCY EXIT MARKINGS.

a. General.

(1) All lettering and markings shall be in Orange-Yellow, No. 33538, MIL-C-46168.

(2) Doors and door frames shall be painted Aircraft Black, No. 37038, MIL-C-46168, in accordance with para 6-22a.

(3) The information in the following paragraphs supplements information in Chapter 7, Section X and in Chapter 8 concerning interior markings for the cockpit area.

(4) Striping on the door shall consist of Orange-Yellow, No. 33538, MIL-C-46168, markings 1/2 inch by 1 inch (positioned lengthwise) spaced one foot apart around the door.

b. Emergency Exit Markings on UH-1.

(1) Remove the word EMERGENCY RELEASE – PULL from the center panel of each cockpit door, and substitute the words EMERGENCY EXIT.

(2) Retain the door handle word OPEN CLOSED.

(3) Remove the words EMERGENCY EXIT from the diagonal forward portion of the door frame.

(4) Add the word EMERGENCY RELEASE-PULL to the diagonal forward portion of the frames with small arrow near the T-handle to indicate direction of hand motion.

c. Emergency Exit Markings on AH-1.

(1) Canopy Jettison. This labeling was used on the AH-1 canopy frame in those aircraft using the older manual canopy jettison system. The newer linear explosive canopy jettison system does not require the use of this labeling on the canopy frame.

(2) Canopy Eject Handles and Labeling. Apply the orange/yellow/black diagonal striping on the handles. The words CANOPY EJECTION are to be 1/4 inch orange/yellow words on the black background.

(3) Exit placards/markings shall read as they originally existed except in Orange-Yellow, No. 33538. on the black background.

d. Emergency Exit Markings on OH-58.

(1) Apply the words EMERGENCY RELEASE on the diagonal forward portion of the door frames as close to the door jettison handles as possible.

(2) Apply the word PULL, with an arrow to indicate the hand motion required, adjacent and just below the door jettison handles.

(3) The door jettison handles shall be painted orange-yellow and black 1/8 inch wide alternate stripes.

(4) Place the words EMERGENCY EXIT on the center of the side panel of the door.

(5). Apply the words OPEN-CLOSED.

e. Emergency Exit Markings on CH-47. Apply the words EMERGENCY EXIT/TURN HANDLE marking adjacent to the door jettison handle.

Section VI. PROTECTIVE COATINGS

6-30. COATINGS FOR FIBER LAMINATE MATERIALS.

a. Sandwich-type laminate parts in aircraft are coated for several reasons with the type of coating being chosen for the specific application of the part. Plastic parts such as radomes are normally coated primarily for rain erosion resistance. Paints shall not be applied to radomes or antennas unless specifically directed in 6-17.

b. In repairing sandwich-type laminate parts, the final step is to refinish the part with a finish identical to the original finish. (Refer to drawings and applicable specifications of the parts).

NOTE

There will be no protective coating sprayed upon radomes for prevention of scratching or marring during transport. As previously emphasized, items constructed of fiberglass material require special handling at all times to prevent damage. Addition of protective coatings for prevention of such damage would not prevent major damage and would tend to reemphasize special handling precautions. Surface will be protected by covering with paper or similar material.

6-31. PROTECTIVE COATINGS FOR RAIN EROSION. Fiberglass laminated surface located on the frontal areas of aircraft are subjected to considerable erosive action when flying through rain. These areas must be protected to prevent severe damage to the fiberglass surface. Rain erosion coating systems conforming to Military Specification MIL-C-83231 and MIL-C-83445 applied to affected surfaces will provide protection from the effects of rain erosion. These materials will protect the fiberglass surface indefinitely, providing the coating is replaced or repaired when inspection indicates such work is necessary. Thermally reflective elastomeric coating system, Military Specification MIL-C-83445 is

a dual purpose coating to be used as a thermally reflective coating on exterior laminated plastic parts where protection from rain erosion is required. For economic reasons, the thermally reflective coating will be used only where both thermal and erosion protection is an established requirement.

a. Rain erosion resistant coating systems, Military Specification MIL-C-83231.

(1) Class A, Type I, is a rain erosion resistant coating furnished in complete kit form.

(2) Class A, Type II, is a rain erosion resistant coating with antistatic surface treatment to minimize radio noise from precipitation charging of the coated surface furnished in complete kit form.

b. Thermally reflective coating system, Military Specification MIL-C-83445, are classified as follows:

(1) Class I rain erosion resistant thermal coating furnished in kit form complete with primer, erosion resistant (electrically nonconductive) component, and diluting solvent.

(2) The coatings are intended for exterior laminated plastic parts of aircraft for protection from rain erosion and thermal energy while the aircraft is in flight. These coatings cannot be used on radomes and other plastic parts that have a requirement for protection against static electrical charges because they are not electrically conductive.

c. Provide rain erosion protection on wing tip assemblies and other aircraft parts constructed of fiber laminates which present an in-flight angle of impact of 15 degrees or more. Do not provide rain erosion protection on leading edges and areas of radomes and antenna housings unless specifically directed in 6-17. Head-on impact of a flat surface is defined as a 90-degree

angle of impact. Angular impact determinations must be based on the position of the part when in a normal inflight attitude.

NOTE

Only the amount of material to be used within the following 8 hours should be accelerated at one time. Material that has been mixed and allowed to stand beyond this period of time should be discarded. Do not attempt to thin any coating material which has gelled beyond brushable use. Keep containers tightly covered when not in use.

6-32. PREPARATION OF SURFACE.

WARNING

METHYL ETHYL KETONE

- Keep away from heat and open flame,
- Keep container closed.
- Use with adequate ventilation.
- Avoid prolonged breathing of vapors.
- Avoid prolonged or repeated contact with skin.

Failure to observe these precautions can result in serious injury or systemic poisoning of personnel.

a. Repair surfaces with pits, scars, scratches, or other minor defects in accordance with TM 55-1500-204-25/1. It has been found that coatings are more satisfactory if the surface to receive the coating is smooth but not glossy.

b. Remove surface gloss with a fine grade of emery or sandpaper, No 240 grit, after sanding slightly with a coarser grade of abrasive so as to finely and uniformly scratch the surface. Remove sanding dust with a clean, lint-free cloth dampened with methylethylketone, Federal Specification TT-M-261, or thinner solvent used with the coating. Assure that surface is completely dry before coating application.

6-33. APPLICATION OF PRIMER AND COATING.

WARNING

Since materials used in coating removal

and application procedures are flammable and toxic in sufficient concentration, standard precautions such as fire prevention and adequate ventilation shall be exercised.

Plastic parts to be coated with erosion resistant coatings should be processed in a sheltered area free from dust, and protected from weather conditions. Best results are obtained if the coatings are applied at relative humidities below 60 percent.

a. Application of Coating System, Military Specification MIL-C-83231.

(1) Mixing. Components of classes A and B, types I and II coatings shall be individually mixed in accordance with the manufacturer's instructions. The resulting individual mixtures shall be smooth, homogeneous materials free from lumps, gelling, seeding, separation or other objectionable characteristics.

(2) Pot Life. Classes A and B coatings shall have a minimum pot life of 4 hours at standard conditions. At the end of the 4 hour period, the coatings shall show no signs of lumping, seeding, separation or an increase in viscosity of more than 20 percent from the initial viscosity

(3) The class A and B coatings shall be applied in accordance with the manufacturer's instructions to a total dry film thickness of 12 to 14 mils. The total application time, including priming and intervals between coatings shall not exceed 8 hours. The tack free drying time for class A coatings shall not exceed 4 hours after application of the final coat. The tack free drying time for class B coatings shall not exceed 10 hours after application of the final coat.

(4) The rate-of-cure of the class A and B coatings shall have a maximum set-to-touch or recoat time of one hour. For class B materials, the manufacturer shall furnish instructions for catalyzing or accelerating the polyurethane prepolymer materials for a temperature range from 10°C to 35°C (65°F to 95°F) and a relative humidity range from 40 percent to 75 percent.

(5) Class A coatings shall be fully cured within 5 days and shall be free of pinholes, cracks,

bubbles or other film irregularities. Class B coatings shall be fully cured within 10 days and shall be free of pinholes, cracks, bubbles, or other film irregularities.

b. Application of Coating System. Military Specification MIL-C-83445.

(1) Mixing. Components of class 1 and 2 coatings shall be individually mixed in accordance with the manufacturer's instructions. The resulting individual mixtures shall be smooth, homogeneous materials free from lumps, gelling, seeding, separation or other objectionable characteristics.

(2) Pot Life. Class 1 and 2 base coating and topcoating solutions shall have a minimum pot life of 4 hours after catalyzation. At the end of the 4 hour period, the coatings shall show no signs of lumping, seeding, separation or an increase in viscosity of more than 20 percent from the initial viscosity when tested in accordance with 4.7.9 and Table 1.

(3) The coatings shall be applied in accordance with the manufacturer's instructions to a total dry film thickness of 12 to 14 mils. The total application time, including intervals between coatings shall not exceed 8 hours and the tack free drying time shall not exceed 10 hours after final application of the coatings.

(4) The rate-of-cure of the coatings shall have a maximum set-to-touch or recoat time of one hour. The manufacturer shall furnish instructions for catalyzing or accelerating the polyurethane base materials for a temperature range from 65° to 95°F (18° to 35°C) and a relative humidity range from 40 to 75 percent.

(5) Class 1 and 2 coatings shall be fully cured within 5 days and shall be free of pinholes, cracks, bubbles or other film irregularities.

6-34. PATCHING OR RETOUCHING DAMAGED COATINGS.

WARNING

METHYL ETHYL KETONE

- Keep away from heat and open flame.
- Keep container closed.

- Use with adequate ventilation.
- Avoid prolonged breathing of vapors.
- Avoid prolonged repeated contact with skin.

Failure to observe these precautions can result in serious injury or systemic poisoning of personnel.

Sand damaged surface to a feather edge. Extend sanded surface beyond damaged areas approximately 1 inch. Clean sanded surface with a clean, lint-free cloth dampened with methylethylketone, Federal Specification TT-M-261 . Immediately wipe with a second dry, clean, lint-free cloth to remove residue and allow to dry thoroughly. Apply primer and coating(s) as previously directed herein. Exercise extreme caution to prevent uneven and excessive buildup of coating when making repairs to radome coatings. Excessive coating thickness will reduce radome electrical transmission efficiency and in the case of doppler and fire control radomes, could result in beam deflection errors beyond tolerable limits.

6-35. REMOVAL OF COATINGS.

WARNING

METHYL ETHYL KETONE

- Keep away from heat and open flame.
- Keep container closed.
- Use with adequate ventilation.
- Avoid prolonged breathing of vapors,
- Avoid prolonged or repeated contact with skin.

Failure to observe these precautions can result in serious injury or systemic poisoning of personnel.

a. Prior to application of neoprene, inspect radomes for damages that penetrate face plies. To prevent the solvent from entering the radome core, cover damages that penetrate face plies with tape. Federal Specification PPP-T-60. Extend tape approximately 3 inches beyond edges of damaged area. Do not attempt to remove coating under the tape. This coating will be removed either with face ply when damaged area is repaired, or by hand sanding.

b. Removal of erosion resistant coatings shall be accomplished by one of the following methods:

WARNING

Handling and use of coating removal solvents requires normal precautions commensurate with their toxicity and flash point characteristics. These solvents tend to dry out the skin and may cause skin disorders to some individuals. Therefore, protection to hands shall be provided by appropriate gloves or gauntlets.

(1) Cover coating with a felt pad or rags and saturate with 50/50 mixture of toluene, Federal Specification TT-T548, and methylethyketone, Federal Specification TT-M-261. Maintain covering in a saturated condition until coating has loosened to the extent that it can be peeled off or scraped off with a phenolic or plastic hand scraper. If a hand scraper is used, care must be exercised to prevent scratching the surface of the radome. Remove residue with a cloth dampness with toluene or methylethylketone.

WARNING

Electrically ground table and pump to guard against static discharge.

(2) The application of a continuous stream of solvent mixture is an alternate method of removing coatings. Suggested equipment consists of a metal table of suitable size with a metal grid top and provisions for draining the solvent through a filter to a low pressure explosion-proof fluid pump. Position radome or part on table with pipes or rods between radome and grid top. To prevent possible delamination of solid laminate edge bands, do not place part directly on, or drag it across, the metal grid table top. Cover coated area as previously described and apply a stream of solvent mixture until coating loosens. Remove coating as previously described.

NOTE

Solvent mixture must not contain more than 50 percent methylethylketone, Federal Specification TT-M-251. Methylethylketone in excess of 50 percent will be harmful to materials. Toluene, Federal Specification TT-T-548, used by itself will satisfactorily remove neoprene coating, however, the reaction time is longer than that for methylethylketone-toluene mixture.

6-36. REMOVAL OF PAINT FROM RADOMES.

Do not remove paint from radomes.

WARNING

When stripping paint adjacent to installed radomes, it is mandatory that paint strippers and solvents do not contact the fiberglass, and are not permitted to flow into edge band areas of radomes. (Refer to Chapter 6.)

6-37. PROTECTIVE COATING FOR THE POLYCARBONATE AND PVC/ACRYLIC POLYMER COVERING ON THE CANOPY EGRESS SYSTEM.

- a. Clean the canopy egress system covering with alcohol, Federal Specification 0-E-760.
- b. Sand surface with 400 grit sandpaper.
- c. Clean the covering again with alcohol, Federal Specification 0-E-760.
- d. Apply Lexcote G-3483 per manufacturer's instructions.
- e. Infrared heat lamp may be used to aid in the curing of the Lexcote.

CHAPTER 7

LETTERING AND MARKING

Section I. MARKINGS

7-1. GENERAL.

a. The color for the majority of markings and lettering will be aircraft black, shade number 37038. MIL-C-46168. on aircraft green or aircraft grey background. The crew areas will normally be marked in orange-yellow. number 33538. MIL-C-46168 on aircraft black background. See details in Chapters 9 and 10.

b. Unless otherwise specified, use 1/2-inch high Arabic numerals and capital letters for markings. If lettering shown in Chapters 9 and 10 cannot be made on standard Army stencil cutting machine due to odd size letters. go to the nearest standard size. For example (shown in figure 8-2), 5/8 in., replace with 1/2 inch. Markings and lettering may be reduced in size to suit combat operation.

c. Center Identification lettering UNITED STATES ARMY as nearly as possible on each side of fuselage. Use 6-inch vertical block letters. Letter dimensions, positions. and locations for each

aircraft will be in accordance with instructions in Chapter 8. When identification lettering UNITED STATES ARMY does not fit on allotted space. use U.S. ARMY or ARMY.

CAUTION

Cutting of fuel, oil, hydraulic, or oxygen lines, or electrical wiring under crash conditions may result in a fire or explosion or increase the severity of an existing fire. Such possibilities will be taken into consideration when emergency escape areas are being chosen for identification markings.

d. Outline corners of emergency exits and rescue exit areas with right-angle corner bands 1 inch wide and 3 inches long at each leg. Paint corner marks with black, shade number 37038, Military Specification MIL-C-46168.

Section II. INSIGNIA: GENERAL

7-2. LETTERING AND MARKING MATERIALS.

a. Apply insignia with approved paint as applicable and compatible with the existing finishes.

b. Use decals conforming to paragraph 6-5, in lieu of paint, if approved by AVSCOM, ATTN: AMSAV-MEA, 4300 Goodfellow Boulevard, St. Louis, MO 63120-1798.

7-3. GENERAL.

a. The National Star Insignia will not be applied to tactical aircraft. The National Star Insignia, of the design shown in figure 8.1, will be placed on other Army aircraft where required as part of an authorized paint scheme.

b. The insignia will portray an insignia white, five-pointed star located within an insignia-blue circumscribed circle. This is referred to as the

basic blue circle. An insignia-white rectangle will be located on each side of the star. The top edge of the rectangles will form a straight line with the upper edges of the horizontal opposed star points. An insignia-red horizontal stripe will be centered in each end of the rectangle. The basic blue circle will outline the entire insignia.

c. The dimensions of the insignia will be determined by the diameter of the basic blue circle, which is standardized in multiples of 5 inches.

7-4. COLORS.

a. Gloss colors for insignia will conform to applicable shade numbers of Federal Standard 595. Insignia red will conform to shade No. 11136. Insignia blue will conform to shade No. 15044. Insignia white will conform to shade No. 17875.

b. Corresponding lusterless colors will also conform to applicable shade numbers in Federal Standard 595.

7-5. APPLICATIONS.

a. Mask off area and apply National Star Insignia over finish top coat. Avoid any method that cause ridges in the application of insignia and markings.

b. Remove masking tape as soon as practicable, but in any case, not later than 2 hours after taping, in order to avoid staining the painted surface.

7-6. FIXED WING AIRCRAFT.

a. Fuselage Insignia Installation.

(1) Location.

(a) When specified, the National Star Insignia will be applied on each side of the fuselage, midway between the wing trailing edge and the leading edge of the stablizer. The insignia may be moved forward, or aft, the minimum distance required to avoid covering transparent material or areas exposed to extreme heat which would scorch or otherwise damage the insignia.

The insignia may extend over doors and emergency exits, but will not extend over window areas or other such openings which will change the design of the insignia. Symmetry will be maintained when applying the insignia on each side of the fuselage.

(b) The insignia will be so applied that in the normal flight attitude of the aircraft, the top point of the star points upward on fuselage surfaces.

(c) Approval of an alternate location for the fuselage insignia will be coordinated with AVSCOM, AMSAV-MEA.

(2) Dimensions (figure 8-1). The insignia will be nearest to, but will not exceed, 75 percent of the fuselage height at the point of application. The diameter of the basic blue circle will not exceed 50 inches nor be less than 20 inches (excluding border.)

b. Wing Insignia Installation.

(1) Location.

(a) The National Star Insignia will be applied on the upper surface of the left wing and on the lower surface of the right wing.

(b) Each insignia will be positioned at a point inboard from each wing tip equal to 1/3 the distance from the wing tip to the wing fuselage mating point. The border of the insignia will be tangent to the aileron cutout. In the case of swept wing or delta wing aircraft, the blue border will touch a line drawn parallel to the trailing edge of the wing, 6 inches forward of the most forward point of the aileron.

(c) The National Star Insignia may be moved inboard the minimum distance necessary when space is not available for the minimum size specified, or to avoid obstructions, such as wing floats, struts, and other externally installed equipment that interfere with discernment of the insignia. However, symmetry will be maintained with the U.S. Army identification markings.

(d) The wing insignia will be so applied that in normal flight attitude, the top point of the star points forward, and a line from the center of the insignia through the top star point parallel to the direction of flight.

(2) Dimensions (figure 8-1).

(a) The National Star Insignia selected for the wing will not exceed a maximum diameter of 60 inches, nor minimum of 20 inches, (excluding border.)

(b) Standard sizes for basic blue circle diameters will be in multiples of 5 inches between these limits.

(c) The diameter of the basic blue circle will be the standard size which is nearest to, but does not exceed, 75 percent of the distance between the wing leading edge and the aileron cutout at the point of application.

(3) Hot areas. The National Star Insignia and the identification marking U.S. Army will not be applied to heat resistant finishes.

7-7. HELICOPTERS.

a. Location.

(1) Four National Star Insignia will be applied on the aircraft fuselage. The insignia will be located so that it will be visible from each side, from above, and from below. Due to various design configurations, the insignia will be located as near the center of the aircraft as is practical so as to provide maximum discernment. Such loca-

tions will be standardized on like model and series helicopters. The insignia may be moved the minimum distance required to avoid high heat areas. The insignia may extend over doors and emergency exits but will not be applied over windows or other such openings which would change the design of the insignia.

(2) The National Star Insignia will be applied on vertical surfaces so that in normal flight attitudes, the top point of the star will point forward in the direction of flight.

(3) If the main fuselage section is not large enough to accommodate the minimum size specified, the star insignia may be placed on such other parts of the fuselage as will permit its being readily seen.

(4) If space limitations and configurations permit, additional insignia will be applied to the nose of helicopters to provide more positive air-to-air identification.

b. Dimensions of Fuselage Insignia

(1) The dimensions of the insignia will be determined by the diameter of the basic blue circle. The insignia will not exceed 50 inches in diameter, nor be less than 10 inches. The selected insignia size will be nearest to, but not exceed, 75 percent of the fuselage height at the point of application. Symmetry should be maintained when applying the insignia on each side of the fuselage.

(2) If the above size is impractical for application, the most practical standard diameter will be selected.

Section III. MEDICAL INSIGNIA

7-8. AIRCRAFT. Those aircraft assigned to the Army Medical service for use as ambulance aircraft will be painted to the standard tactical paint scheme and will be marked with a red cross centered on a white field as shown in Chapter 9. The cross shall be painted MIL-C-46168, Aircraft Red, #31136.

7-9. AIRCRAFT FIRST AID KITS AND LITTERS.

a. First Aid Kits.

(1) When painting identification markings on aircraft first aid kits, the red cross will be com-

posed of five 1/2 inch squares arranged in a symmetrical cross. The lettering will be 1/2 inch high and National Stock Number will be 5/6 inch high with 1/4 inch space between lines (See figure 8-6). Markings will be applied using MIL-C-46168, aircraft red #31 136 for the cross, MIL-C-46168, and aircraft black #37078, for the lettering.

(2) If the kit is enclosed in a cover or installed in a bracket or holder which hinders the visibility of the marking on the kit, an additional red cross will be placed on such cover, bracket, or holder. If this is not practical, the red cross will be

placed on the structural part of the aircraft near the cover, bracket, or holder.

(3) If background areas on which the red cross is to be painted will impair visibility of the cross, a solid white square equal to or slightly larger than the overall dimensions of the red cross may first be painted in that area to provide a contrasting background. Use MIL-C-46168, aircraft white #37875.

b. Litters. Paint red cross markings on litters using appropriate colors of paint MI L-C-46168. Litters, where painted, will be painted in MIL-C-46168 forest green.

Section IV. COMMAND AND ORGANIZATIONAL INSIGNIA AND NAME

7-10. GENERAL. Command and/or organizational insignia, which has previously been authorized by Headquarters Department of the Army, may be applied to Army aircraft upon approval of major Army field commanders. Using organizations will be responsible for the application and subsequent removal of insignia before transfer of the aircraft to another activity. Depot maintenance facilities will not replace command and/or organization insignia. Such insignia will be applied over MIL-C-46168 paint.

7-11. COLOR, LOCATION, AND SIZE.

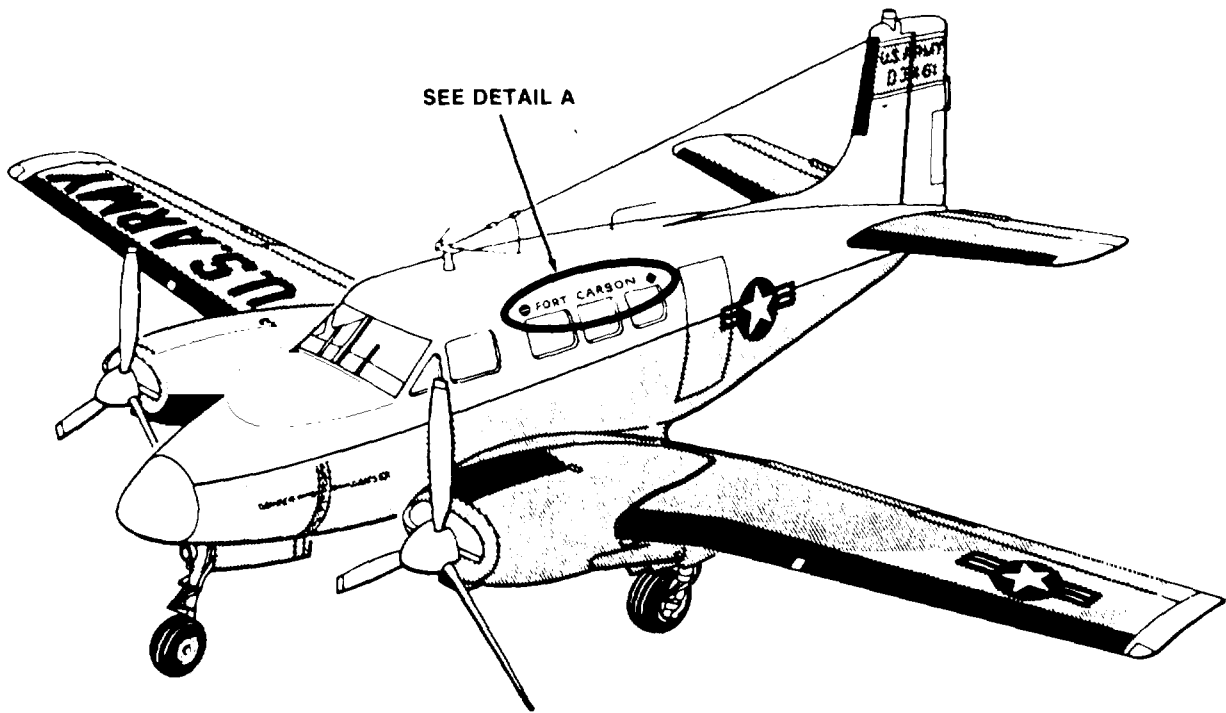
a. Color. Because bright colors will aid in the visual acquisition of combat aircraft and degrade the effectiveness of the standard Army tactical paint schemes, unit and organizational insignia on tactical aircraft will only be painted lusterless black and olive drab. Non-tactical aircraft will have these insignia painted only in authorized topcoats and colors approved by Headquarters, Department of the Army.

b. Location. On fixed wing aircraft, the organizational insignia will be located in accordance with figure 7-1 or will be confined to that

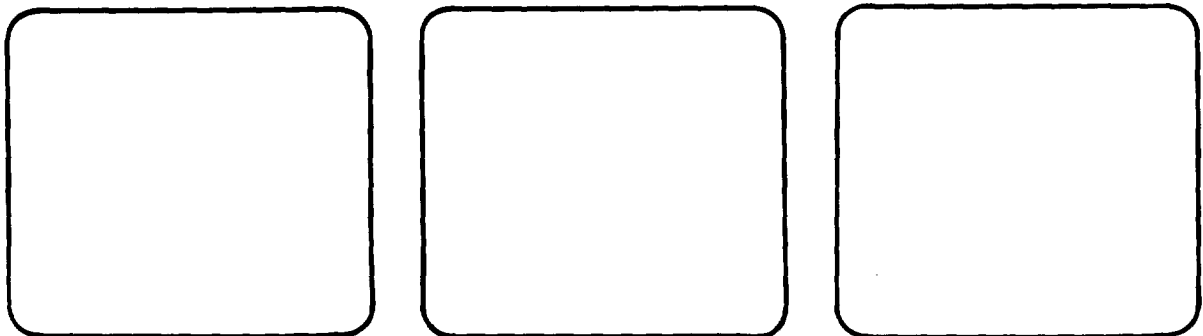
portion of the vertical stabilizer above the radio call numbers excluding the rudder, and will be applied to both sides, or each outboard side as applicable, (e.g., OV-1). On helicopters the insignia will be applied to each side of the fuselage, aft of the radio call numbers. However, on some helicopters and fixed wing aircraft, adequate space may not be available at that exact location. In such cases, the insignia or lettering should be positioned as near as possible to the specified location. Staff Transport (VIP) aircraft may have the command insignia, command, or home station name, and organization insignia applied to both sides of fuselage above the cabin windows.

c. Size of Insignia. If placed on the vertical stabilizer, insignia will not exceed 75 percent of the height of the allocated portion of the vertical stabilizer. If placed above the cabin windows, the insignia will not exceed the size of the U.S. Army on the vertical stabilizer.

d. Size of Lettering. Lettering for the name of the command or home station will not exceed two-thirds of the size of the U.S. ARMY on the vertical stabilizer.



 **FORT CARSON** 



DETAIL A

Figure 7-1. Command and Organizational Insignia and Name.

Section V. IDENTIFICATION LETTERING

7-12. GENERAL.

a. Style. Unless otherwise specified, identification lettering, ARMY, U.S. ARMY, or UNITED STATES ARMY, will be presented in vertical block letters. All letters should be of the same block design.

b. Dimensions.

(1) For tactical TDA helicopters and fixed wing aircraft, the height and location of lettering may vary on aircraft of different size and model and space available, but the size and location of this marking will be the same on all aircraft of the same model.

(2) For non-tactical TDA helicopters and fixed wing aircraft, letters will be of uniform size, with the letters separated from the numerals with a dash. Depending on the fuselage surface available, letters will be in the largest size practicable: however, in no case will they be smaller than 8 by 12 inches, or larger than 32 by 48 inches. The height of identification lettering near the star will be the diameter of the basic blue circle. Exception of these dimensions will be taken when the allotted space does not allow for the dimensions prescribed herein.

c. Uniformity. Aircraft identification lettering will be standardized and uniformity maintained on similar type aircraft in each organization.

d. Restriction. The Army identification lettering and the National Star Insignia when appropriate, will not be altered in location, dimension, or configuration from the specifications reflected herein to accommodate any major command and organizational insignia or marking.

7-13. FIXED WING NON-TACTICAL.

a. Fuselage. The fuselage identification marking for all Department of Army Reserve and Army National Guard aircraft will consist of ARMY in vertical block type lettering placed on the

side of the fuselage. An exception may be made in the case of aircraft painted in gloss OD and gloss white paint scheme. Army may be omitted at the option of the local major field commander.

b. Wing.

(1) Identification. The identification lettering on wings of all Department of the Army, Army National Guard, and United States Reserve aircraft will consist of U.S. ARMY in vertical, block-type lettering of uniform size.

(2) Location. This marking will be centrally placed on the lower surface of the left wing and upper surface of right wing as shown in the applicable illustrations.

(3) Dimensions. The height of this marking will be the same height as the basic blue circle in the National Star Insignia on the opposite wing of the aircraft. Width of letters will be two-thirds the height of the letter: width of strokes and spaces will be one-sixth the height of the letters. The top of the letters will be toward the leading edge of the wing.

(4) NG. Marking NG will not be applied on aircraft wings.

7-14. HELICOPTERS, NON-TACTICAL.

a. General. The identification lettering on the fuselage of all Department of the Army, Army National Guard, and United States Army Reserve helicopters will consist of the letters ARMY placed on each side of the fuselage.

b. Specific Application. The ARMY markings will be placed on each side of the fuselage of helicopters as shown in appropriate illustrations.

NOTE

The paint to be used for application of letters and markings specified in Sections VI thru X shall be the same as that used to finish the surface to be marked.

Section VI. WARNING STRIPES AND SIGNS

7-15. PROPELLER AND ROTOR BLADE WARNINGS, NON-TACTICAL AIRCRAFT.

NOTE

Provisions of section VI are subject to an international standardization agreement (Cento Stang 3250).

a. Exterior. That area of the fuselage which is behind the plane of the propeller path will be marked with a glossy insignia-red stripe 3 inches wide, extending completely around the fuselage, except through anti-glare areas and when it does not interfere with standard ARMY markings or insignia. A 3-inch space will be maintained between the ends of the propeller warning stripe and any standard Army marking or insignia. The word PROPELLER, reading vertically from the top to bottom, will be super-imposed in this stripe in glossy insignia-white letters 2 inches high, placed at sufficiently frequent intervals to indicate the dangerous areas. The DANGER will be applied perpendicular to the word PROPELLER on each side of the warning stripe, with an arrow pointing from the DANGER toward the stripe. Letters in the word DANGER will be 2 inches high and the arrows will be 4 inches long. The word DANGER and the arrows will be in glossy insignia-red, shade No. 11136. This marking applies to all non-tactical multiengine aircraft.

b. Interior. Openings used as exits within 6 feet of the propeller disc will have an insignia-red warning stripe 3 inches wide painted on their inside surface. Stripes will extend from the center of the fuselage or the top of the opening, whichever is higher, to the lowest extremity of the opening. The word PROPELLER, reading vertically from top to bottom, will be super-imposed on the stripes in glossy insignia-white letters 2 inches high, placed at sufficiently frequent intervals to indicate the dangerous areas. The word DANGER in glossy insignia-red will be applied perpen-

dicular to and centered with respect to the word propeller on each side of the stripe, with an insignia-red arrow pointing toward the stripe. Letters will be 2 inches high and arrows 4 inches long.

c. Tail Rotor Markings, Non-tactical

(1) Tail rotor blades. See Chapter 6.

(2) Tail rotor warning markings, non-tactical. See Chapter 9.

d. Tail Rotor Markings, Tactical.

(1) Tail rotor blades. See Chapter 6.

(2) Tail rotor warning markings. Paint warning arrows Aircraft Black, #37038. Paint word DANGER above warning arrow in Aircraft Black #37038. See Chapter 9 for dimensional data.

7-16. OV-1 AIRCRAFT. A warning stencil to prevent injury to personnel performing maintenance on OV-1 aircraft, incorporating air conditioning systems, shall be installed as noted in Chapter 10.

7-17. NOISE HAZARD LEVELS AND STENCILS.

a. Sound pressure levels in Army aircraft during some operating conditions exceed the Surgeon General's hearing conservation criteria, as defined in TB MED 251. Hearing protection devices, such as the aviator helmet or ear plugs, are required to be worn by all personnel in and around the aircraft during its operation.

b. Noise hazard stencils will be applied to provide conformance to the standard details prescribed in MIL-STD-1474 (Noise Limits for Army Material). The stencil, in the orange-yellow #33538 shall read as shown in figure 7-2.

c. The stencils will be applied in Army aircraft and located so they are visible to all passengers who are not normally required to wear aviator helmets or headphones. The aircraft affected, including the location of stencils are as follows.

(1) UH-1B/C/M Helicopters. Apply stencil to interior surface of each cargo door below the windows.

(2) UH-1D/H Helicopters. Apply stencil to interior surface above cargo door glass at station 102.0 on both sides.

(3) CH-47 Helicopters. Apply stencil each side of the interior surface of aircraft and locate over the back of troop seats above each window (4 locations on each side). (See paragraph d for stencil information.)

(4) CH-54 Helicopters and Universal Military Pod. Apply stencil on each side of the interior surface of the pod. Locate above the back of troop seats (4 locations on each side). Space so the lettering is visible to all troop positions.

(5) OH-6 Helicopters. Apply stencil to the rear of forward bulkhead on each side. Locate so lettering is readily visible to each passenger.

(6) OH-58 Helicopters. Apply stencil to blanket assembly at approximately FS 97.50 and WL 67.

(7) OV-1 and RV-1 Aircraft, Apply stencil to observer's panel. Locate so the label is readily visible to an occupant in the right seat.

(8) U-21 and RU-21 Aircraft.

(a) Attach label (P/N 7690-EG-000-2) to exterior surface on cargo door, adjacent to the main entrance door, on left side of aircraft. Locate at mid-height of doorway.

(b) Attach label (P/N 7690-EG-000-1) to the rear of pilot and copilot seat. Locate for maximum visibility of passengers.

NOTE

On aircraft equipped with VIP kit, installed per ECP #100019, put label on the passenger side of the forward bulkhead so that it is visible to all passengers.

(9) U-8F Aircraft.

(a) Apply stencil to the exterior surface on left side of the aircraft, adjacent to the access door.

(b) Apply stencil on forward bulkhead. Locate on the bulkhead so label or stencil is visible to all passengers (see paragraph d for stenciling).

(10) T-42 Aircraft.

(a) Attach label (P/N 7690-EG-000-2) to the exterior surface of aircraft adjacent to the passenger door.

(b) Attach label (P/N 7690-EG-000-2) to the passenger window sill on interior of each side of aircraft.

(11) C-12 and RC-12 Aircraft.

(a) Attach label (P/N 7690-EG-000-2) to the exterior surface centered on the passenger door that is on the right side of the aircraft.

(b) Attach label (P/N 7690-EG-000-1) or stencil lettering to the rear of pilot and copilot seat. Locate for maximum visibility of passengers.

(12) AH-64 aircraft. Apply stencil to right side lower area of both crewstations.

(13) AH-1 aircraft. Apply stencil to right inside lower area of both crewstations.

(14) UH-60 Helicopter.

(a) Apply stencil to the interior surface of cargo door centered on the center post between the windows (both sides).

(b) Apply stencil to interior surface at station 300, water line 244 (both sides).

d. The adhesive backed labels are for use on aircraft hard surfaces only. For aircraft requiring labels over fabric-lined or acoustical-blanketed interior areas, cut or procure a stencil locally. For size and wording of stencil, see figure 7-2.

e. The stenciled letters shall be lusterless black for gray backgrounds and lusterless orange for black backgrounds.

f. Apply or remove pressure sensitive labels in accordance with instructions in TM 55-1500-204-25/1.

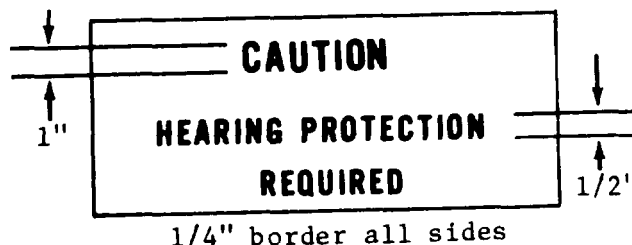


Figure 7-2. Size and Wording of Stencil

Section VII. RADIO CALL NUMBERS AND PREFIXES

7-18. RADIO CALL NUMBERS.

a. General.

(1) Radio call numbers for Army aircraft will consist of five numerals, Radio call numbers will be derived from the aircraft serial number. Vertical block-type Arabic numerals will be used when applying radio call numbers.

(2) First numeral of the contract year and the hyphen in the aircraft serial number will not be used in radio call numbers. If five numerals are not available in the aircraft serial number, zeros will be used to produce the required five numerals. Should more than five numerals be available, the last five numerals of the aircraft serial number will be used. Example: For serial number 59-5434, use 95434: for serial numbers 59-653472, use 53472: for serial number 59-7, use 90007: for serial number 60-7, use 00007.

(3) Since numbers once assigned may reach an age of 10 years or more, there is a possibility that two sets of radio call numbers could be identical. To prevent this, the symbol (0) will precede derived numbers of more than 10 years of age.

Example: for serial number 50-7, use 0-00007.

(4) All radio call panels installed with aircraft, including helicopters, will be revised to reflect the five radio call numbers applied on the aircraft, and the six numerals if aircraft are over 10 years old.

(5) Radio call numbers will be applied on both sides and on each outboard side, as applicable, of vertical stabilizer and rudder assembly, except that on helicopters they will be applied to sides of fuselage or vertical fin.

(6) Radio call numbers on tactical aircraft will be 6 inches high. If space is not available for this standard size, the size will be of largest size which can be applied and compatible with existing space. For non-tactical aircraft only, the suggested minimum size for space occupied by one call number or designator is 12 inches high by 8 inches wide. If space is not available for this standard size, the size will be of largest size which can be applied and compatible with existing space. Alternate numerical size will be established by the width equaling two-thirds the height, and the stroke and space will equal one-sixth the height. Vertical block-type numbers will be used for radio call numbers.

b. Decals. Decalcomanias conforming to paragraph 6-5 may be used in lieu of paint when applying and maintaining radio call numbers on non-tactical aircraft.

c. Prefix — National Guard. Army National Guard will have a compound prefix in black lusterless letters consisting of the state abbreviation (table 8-4) followed by a dash and letter "NG" in

the space normally occupied by "US ARMY" above the radio call numbers, Identification will be applied on vertical fin of fixed wing aircraft and above or adjacent to call numbers on rotary wing aircraft depending on space available. Letters will be 6 inches high in black color shade 37038. Where space is not available, the "NG" and state abbreviation will be reduced to 2/3 its size to accommodate space available

Section VIII. SERIAL NUMBER AND FUEL SPECIFICATION

7-19. FUSELAGE. The aircraft model designation, serial number and fuel data will be applied to all Army aircraft. See Chapters 9 and 10 for specific guidance for a particular aircraft. Use paragraph 7-20 if no specific guidance for a particular aircraft is shown in Chapters 9 and 10.

7-20. MARKINGS. Show aircraft type, serial number and specific fuel from operator's manual.

a. Example.

U . S . Army U H - 1 D *
U.S.A. Serial No. XX-XXXX

Service this aircraft with MIL-T-5624 Grade JP-4* Aviation Fuel. If not available, refer to TB 55-9150-200-24 for Alternate (Emergency) * fuel.

* Underlined items applicable to specific aircraft types.

b. Location. On left side of aircraft in vicinity of cockpit window.

c. Letters and numerals to be 7/8 in. plus or minus 1/8 in. for model and serial number and 1/2 in. for fuel information.

Section IX. MARKINGS FOR EMERGENCY ENTRY or EXIT

7-21. GENERAL. Markings for emergency exit from aircraft will be orange-yellow shade 33538. Emergency entry will be marked with a broken band in the colors specified in Chapters 9 and 10.

7-22. SECONDARY OPENINGS. Secondary openings, such as auxiliary exits, windows, and navigator's domes are usually smaller than primary openings, making entrance or exit more difficult. If the structure immediately surrounding secondary openings is free from heavy structural members (such as bulkheads and main longitudinal members), oxygen, fuel, and oil lines, and battery leads, it will be marked with a broken band in the colors specified in Chapters 9 and 10. The band will be placed at the extreme boundary of the above described area, both inside and outside of the fuselage. Segments of the broken band will be 1/2 inch wide, 1 inch long and approximately 12 inches apart. Where the band will be covered by soundproofing (or lining), the soundproofing (or lining), will also be marked. CUT HERE FOR EMERGENCY RESCUE will be marked or stenciled inside of, parallel with, and adjacent to, the broken band identifying the area on the outside of the aircraft where forced entry can be made for rescue purposes. CUT HERE FOR EMERGENCY EXIT will be marked on a similar location inside the aircraft. Letters will be 1 inch high. If the letters (on the skin) are covered by soundproofing (or lining), the letters will also be marked on that part of the soundproofing (or lining) that covers that area.

7-23. RELOCATION. Each aircraft will be visually inspected for areas which may be cut through for rescue when entrance or exit cannot be made in any other manner. Visual inspection must be used, as relocation and reinstallation of equipment and furnishings may have been made which would not be indicated on the installation drawing of the aircraft. These areas should be as close to normal stations of personnel as possible, except that they will not be placed at spots where personal injury to occupants probably would result from forced entry. Corner markings will be

painted or stenciled on the inside and outside of the fuselage, marking the limits of these areas. The horizontal and vertical bars of the corner markings will be 3 inches long and 1 inch wide. CUT HERE FOR EMERGENCY RESCUE will be painted or stenciled in the center of the four corner markings on the outside of the aircraft and CUT HERE FOR EMERGENCY EXIT will be placed in a similar location inside the aircraft. Letters will be 1 inch high. Soundproofing also will be painted if it covers markings or words. These markings need not be placed on aircraft so constructed that openings could not be cut with safety.



Do not use a knife or metal blade on aircraft during application procedure.

7-24. ESCAPE PANELS - INTERNAL MARKINGS.

a. Markings for identification of escape hatches, doors, and exits on the inside of aircraft will be marked orange-yellow, shade No. 33538.

b. An orange-yellow #33538 broken band will mark the complete periphery of escape exits or doors. The broken band will be only on the door, and not on the frame of the door. Segments of the broken band will be 1/2 inch wide, 1 inch long, and approximately 12 inches apart (See MIL-A-25165). When the soundproofing (or lining) will cover the identification marking band on the inside of the aircraft, it will also be appropriately marked.

c. The words EMERGENCY EXIT in orange-yellow No. 33538, will be marked or stenciled on the escape hatch, door, or exit, in the most readily visible location. Letters preferably will be 2 inches high, and will be not less than 1 inch. If the letters (on the skin) are covered by soundproofing (or lining), the letters also will be stenciled on that part of the soundproofing (or lining).

d. Small handles or levers used to actuate doors or hatches shall be identified by alternate orange-yellow and black stripes, 1/8 inch in width, painted on the background of the panel. Alternate orange-yellow and black stripes 1/8 to 1/4 inch in width, shall be applied directly onto large levers or exit controls. Background striping shall be applied at a 45-degree angle from the vertical, rotated clockwise. Handles and small levers shall be striped with alternate colored rings. The striping shall not interfere with other types of markings or codings. Suitable descriptive wording, readily visible, will be marked or stenciled on the door or structure of the aircraft whichever is nearer to the emergency release, to identify and explain its operation. This wording preferably will be 1 inch high, and will be not less than 1/2 inch high. Standard English terminology will be used, such as PULL, PUSH, TURN, or SLIDE.

e. Exits which are adequate for air, ground, and ditching escape shall have the words EMERGENCY EXIT centered in the most visible location on the inside of the door or hatch.

f. Exits which are not adequate for all three phases of escape shall be marked EMERGENCY EXIT, followed by

the words AIR, GROUND, OR DITCHING USE ONLY, as applicable.

Example: GROUND USE ONLY, GROUND, AND DITCHING USE ONLY, etc.

7-25. ESCAPE PANELS — EXTERNAL MARKINGS (NON-TACTICAL AIRCRAFT).

a. Markings identifying escape hatches, doors, and exits on the outside of aircraft will be marked gloss yellow on dark surfaces, and gloss black on light surfaces. If enamel is used it will conform to Federal Specification TT-E-489; if urethane is used, it will conform to Military Specification MIL-C-83286.

b. All external releases for operation of emergency exit panels will be marked EXIT RELEASE on the outside of the aircraft to facilitate quick identification. The wording that describes the operation of the exit release will be standard English terminology, such as PULL, PUSH, TURN, or SLIDE. Letters preferably will be 2 inches high and will be not less than 1 inch high.

Section X. MISCELLANEOUS MARKINGS

7-26. GENERAL. Markings of interior and exterior surfaces, labels, decals, placards, and stencils will be applied in accordance with manufacturer's instructions. The materials (polyurethane, lacquer or enamel) used applying the background will be the same as that used to finish the surface. Installations in aircraft cockpits of placards required by TB's or MWO's will be accomplished by coating the back of the placard with a clear lacquer, varnish, or similar substance. The placard will be further secured by an additional coat of clear lacquer, varnish, or similar substance over the front of the placard. If desired, such placards may be made of photo sensitive anodized aluminum. Military Specification MIL-P-10524, Type H, or other metal, and attached to the surface of the aircraft cockpit by bolts or screws.

be applied to aircraft assigned to remote areas when authorized by the major Army field commander.

7-28. MARKINGS FOR TANK AREAS AND INTERNAL STATION MARKINGS.

a. Data Markings. Additional data such as coolant mixture, water, alcohol mixture, oil tank level restrictions and fuel grade (specified) will be applied near the filler caps in letters 1/2 inch high

b. Fuel Nozzle Grounding. The grounding receptacle symbol indicates where the grounding plug shall be inserted to accomplish the grounding process. The symbol and lettering will be painted MIL-C-46168, aircraft black, number 37038 per MIL-C-83413/9-2. See figure 7-12 for dimensions

7-27. BILINGUAL MARKINGS. Bilingual markings will

c. Fuel Tank Filler Areas. Fuel tank filler caps will be painted the same as the color scheme of the aircraft. A 1 inch wide ring (annulus) with a 6.0 inch inside diameter (or as indicated in Chapter 9 or 10) will be painted around the filler cap, black for tactical aircraft, red for all other paint schemes.

d. Internal Station and Compartment Markings. When applicable, internal station and compartment markings will be retained. Aircraft -10 or the -20 manuals will be used to determine station location. Station markings will appear as indicated in figure 8-4.

7-29. OXYGEN OUTLETS. Mark all oxygen outlets — WARNING, NO SMOKING WHILE OXYGEN IN USE.

7-30. LIFT POINTS. All lift points will be indicated by an arrow pointing to the lift point. The word LIFT will be marked above the lift point in letters 1/2 inch high. Notations, such as NO LIFT or NO PUSH, should be applied on areas of aircraft which would be subject to damage by such action.

7-31. STRUT NUMBERS. All wing struts will be numbered with the part number. The number will be located at the lower end, with the top of the letters and numerals forward.

7-32. ELECTRICAL CONNECTIONS. A warning will be painted at the points where it is necessary to break electrical connections when removing wings, tail booms, or other assemblies containing hidden wiring. The letters will be of sufficient height to provide a permanent, distinct, and legible marking.

Example:

CAUTION

Disconnect electrical wiring before removing wings.

7-33. WALKWAYS. Areas immediately adjacent to the walkways will be marked NO STEP in accordance with chapters 9 and 10.

7-34. NATO SYMBOL MARKINGS OF AIRCRAFT SERVICING POINTS.

a. The U.S. Army has ratified a NATO Standardization Agreement (STANAG) NO. 3109., ABC AIR STD 51/2, and STANAG 3230 which promulgates standard aircraft markings. The standard markings will facilitate cross-servicing of NATO aircraft, thereby insuring more effective cross-service operations. NATO symbols will be retained only on aircraft assigned to NATO areas.

b. The servicing and precautionary markings of Army aircraft will be in accordance with the symbols shown and described herein.

c. Symbols will be approximately 4 inches in the longest dimension, except where otherwise specified. However, smaller sized symbols may be used if required by the item or area to be marked. (See Chapter 8).

d. Lettering which supplements the symbols will be in the scale of 1 to 4 in relation to the symbol. (See Chapter 8).

e. Access doors or panels to the servicing points will be marked with appropriate servicing symbol or symbols.

f. Normally markings will be in black, except ground handling and safety point which will be marked in orange.

g. Colors will be in accordance with Federal Standard FED-STD-595. The following basic colors, which are specified with symbol or function,

' will be used unless otherwise indicated:

COLOR	NON-TACTICAL	TACTICAL
Black	No. 17038	37038
White	No. 17875	37875
Red	No. 11136	31136
Orange-yellow	No. 13538	33538
Yellow	No. 13655	33538
Green	No. 14110	34110

h. For NATO symbols or codes on fuels and lubricants, refer to TB 34-9-25.

i. The symbols and colors are in accordance with international agreements. (See Chapter 8). Any changes or recommendations will be processed through departmental standardization offices so that appropriate action may be taken respecting the international agreement concerned.

7-35. AIRCRAFT PLATES FOR GENERAL OFFICERS.

a. General. If desired, star plates may be displayed on Army aircraft. Star plates will be mounted on both sides of the aircraft; however a specific location for mounting the plates is not prescribed herein due to the various design characteristics involved.

b. Material and Size, Plates will be constructed of sheet metal 6 inches high by 9 inches wide.

c. Method of Marking. Grade will be designated by five-pointed white stars, 2 inches in diameter, with one point upward, equally spaced on the horizontal center of the line of the plate. The plates will be painted with gloss red, shade No. 11136, and the 5 pointed stars will be painted gloss white, shade No. 17875.

7-36. JETTISONABLE COMPONENTS.

a. Canopies. Jettisonable aircraft canopies will have the aircraft serial number stenciled on the outside of the canopy frame, on the left-hand side, 6 inches from forward end. using 1-inch numbers and letters provided sufficient space is available. If sufficient space is not available to accommodate 1-inch numbers and letters, they will be as large as space permits. Also, aircraft utilizing cartridge actuated devices will be marked in accordance with Chapter 10.

b. Ejection Seats. A black equilateral triangle with 9-inch sides and with apex pointing downward, with the word DANGER on each side of the triangle, will be applied on each side of the fuselage. The words EJECTION SEAT in black letters will be painted above the triangle. Additional notations will be optional.

7-37. FLUID LINE IDENTIFICATION.

Fluid lines will be identified as specified in Military Standard MIL-STD-1247.

7-38. STORAGE BATTERIES. The notation "BATTERY LOCATION" with location given will be placed on the left side of the fuselage or tail boom as viewed from the rear of the aircraft. The label "BATTERY LOCATION" may be omitted only if the battery access is located where label would normally be placed.

a. The fore and aft location of the marking will be approximately in line with the trailing edge of the wing.

b. The vertical location of the marking will be at a point 2 to 3 feet off the ground with the airplane in the wheels-up position and resting on the ground, or in the case of airplanes having fixed landing gear, with the landing gear collapsed. When battery is accessible via a panel or door, the notation "BATTERY ACCESS" will be marked in block letters not less than 1/2 inch high on battery access door. In the event of interference with windows, enclosures, etc. the marking will be placed as near the above mentioned location as practicable. Either stencils, or a decalcomania, conforming to paragraph 6-5 may be used to apply the marking.

c. The lettering of battery location will be 7/8 inch plus or minus 1/8 inch in height. The marking will be black shade No. 37038, on aircraft green and gloss black, on aluminized or international orange and white painted surfaces.

7-39. AMERICAN FLAG DECALS.

a. The American flag will be applied to Army aircraft which support relief operations outside continental limits of the United States, unless specifically prohibited by the Unit Commander.

b. Decals should be placed in a horizontal position on each aircraft. Minimum decal size for CH-47 and larger aircraft should be 34 inches X 17-1/2 inches, and for UH-60 and smaller aircraft, 17-3/4 inches X 9-3/4 inches.

c. The American flag decal is to be positioned on vertical stabilizer of fixed wing aircraft, on CH-47, and the cargo door of Utility Rotary Wing Aircraft. Decals will be placed on major sheet metal structure of medical service aircraft and other rotary wing aircraft.

d. The American flag, when located on aircraft, should be positioned horizontally in such a manner that union (blue field) should be upper-most with stripes of the flag trailing at all times.

e. Flags printed on pressure-sensitive tapes are to be procured locally.

7-40. DESCRIPTION OF EXTERIOR PAINT SYSTEM.

a. Use this paragraph if no specific guidance for a particular aircraft is shown in Chapters 9 and 10.

b. Show painter's name or code, date, wash Primer (WP), primer (P), and top coat (L for lacquer, C for coatings, etc.) and quantity of coats. Painter can be Government, for example, "NCAD", or Commercial.

c. Example:

** WPI-P2-L3 Date

- WP — indicates wash primer used
- P — indicates primer used
- L — indicates lacquer used (if req'd)
- C — indicates coating used (if req'd)

d. Location. On left side of aircraft below the Serial Number and Fuel Specification. Also enter the above information in the applicable DA form 2408-15.

Section XI. MARKING OF INSTRUMENTS

7-41. GENERAL.

a. This Section provides the general method of marking aircraft instruments, the interpretation of these markings, and specific instructions for the application of the markings.

NOTE

This Section is the subject of International Standardization Agreement STANAG No. 3436.

b. ACTUAL MARKINGS AND FUEL GRADE FOR SPECIFIC AIRCRAFT.

The actual markings for specific aircraft and the fuel grade to which any set of markings apply may be determined by reference to the instrument markings presented in the -10 Operator's Manual for the aircraft involved.

c. INTERPRETATION OF THE RANGE MARKINGS.

The instrument range markings are designed to

indicate to the pilot, at a glance, that flight operation is being accomplished in a safe, desirable, or unsafe region. Generally speaking the instrument marking system consists of four colors and intermediate blank spaces as illustrated in the fictitious instrument in figure 7-3.

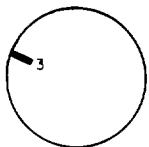
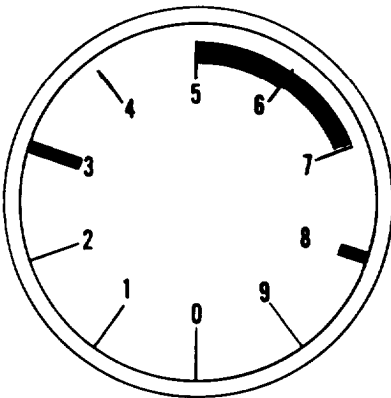
d. INDEX MARK.

The index mark is used to indicate any movement between the glass and the case and thus reveal any errors in the location of the markers by such movement.

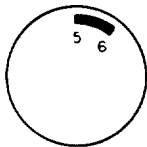
e. Deleted.

f. MIXTURE CONTROL QUADRANT MARKINGS.

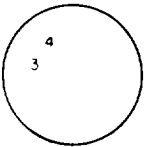
These markings are used to identify the automatic lean and automatic rich positions on the control quadrant.



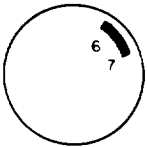
(Danger) Red radial at 3.-
A dangerous condition exists if the pointer is ever below this marking during flight.



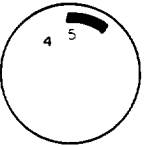
(Auto-lean) Blue arc from 5 to 6.-
Indicates auto-lean operation is permitted.



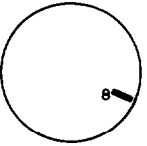
(Caution) Yellow arc from 3 to 4.-
Indicates that danger may exist under certain conditions.



(Desirable or auto-rich) Green arc from 6 to 7.-
Indicates region for continuous operation. When used in conjunction with blue markings, green takes on a special meaning requiring auto-rich operation when the pointer is in this region.



(Undesirable) Blank space from 4 to 5.-
Indicates region that should be avoided or region in which operation is limited.



(Danger) Red radial at 8.-
Operation above this value is prohibited.

Figure 7-3. Sample Markings

7-42. METHOD OF MARKING.

a. Normally the markings will be placed directly over the instrument graduations as in the sample instruments. However, if in this position the markings should interfere with instrument readings from the normal crew position, it is permissible to move the marker above or below the graduations as required. Care must be taken to assure that the markings cover the correct range when they are moved towards the center. It will be noted that the length of the marking required to cover given instrument range becomes smaller as it is moved closer to the center of the dial. (See figure 7-4, detail A.) To avoid possible error, it is suggested that lines be drawn from the extremities of the graduations to be encompassed, to the center of the dial. The marking can then be placed anywhere within these two lines. Every effort should be made, however, to keep the markings as far from the center of the dial as possible.

b. Instruments with multirotation pointers will have the number of times that the pointer crosses zero indicated by short dashes at right angles to the marking, as illustrated in figure 7-4, Detail B. It will be noted that the green arc extends from 1700 to 2300 and that the red radial is at 2500.

7-43. APPLICATION OF MARKINGS.

a. **RANGE MARKINGS.** The instrument range marking will be made using tape, Federal Specification A-A-113, the alternate method range marking may be made using lacquer, Federal Specification TT-L-32, in the color desired. For night vision use tape, reflective Federal Specification L-S-300, in the color desired. (Reference Table 8-3).

(1) Clean the surface of the gage to be marked, making sure all dirt, oil and grease have been removed.

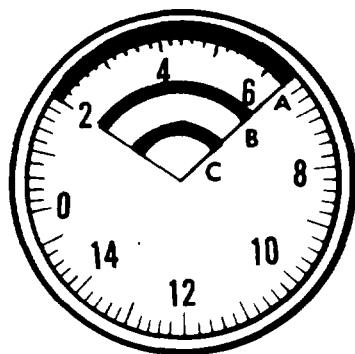
(2) Cut the tape to desired ARC length and color desired, approximately 1/16 of an inch thick.

(3) Apply the tape making sure all bubbles and wrinkles have been removed.

(4) For lacquer marking clean surface as (a) above, making the range markings approximately 1/16 of an inch thick in the color and range desired.

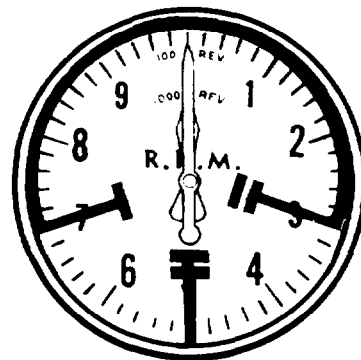
NOTE

All operating ranges will be established using the applicable Aircraft Operators Manual.



NOTE: Marking should be at A or B—not C.

DETAIL A



DETAIL B

Figure 7-4. Method of Marking

NOTE

Where conditions permit on 1 inch and 2 inch clamp mounted indicators, which have the numerals and graduations on the outer circumference of the dial the fluorescent range marks will be installed on the front edge of the case just outside the cover glass. In those instances where the foregoing does not apply refer to the instrument markings presented in the -10 Operator's Manual.

(5) After allowing the applied marker to air dry for 30 minutes, trim to exact size and paint over the marker with another coat of varnish.

NOTE

If it is desired to remove any excess varnish, this may be done within 1/2 hour after application with a cloth dampened with naphtha.

b. INDEX MARK. A white index mark not over 1/16-inch wide will be painted across the joint between the glass and the case at the bottom of the center (6 o' clock) position, or in the uncalibrated area of all instruments having range markings on the glass. On panel installed clamp mount type instruments, the mark will be extended across the edge of the instrument case onto the mounting panel. On clamp mount type instruments, not panel installed, the mark will be extended across the rim of the case, onto the case. On instruments utilizing the entire circumference of the dial for calibration increments the location of the index mark will be left to the discretion of the using activity.

c. MIXTURE CONTROL QUADRANT MARKINGS.

Mark the automatic lean position with gloss cellulose nitrate lacquer, light blue, Federal Specification TT-L-32. Mark the automatic rich position with gloss cellulose nitrate lacquer, light green, Federal Specification TT-L-32. (See figure 7-5).

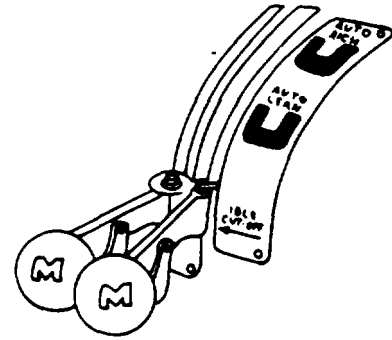


Figure 7-5. Mixture Control Quadrant

NOTE

The following paragraphs describing the markings for the various types of instruments attempt to cover all possible markings for each instrument. It should be noted that the illustrated instruments are typical and may or may not include all the markings mentioned in the descriptive paragraphs.

NOTE

It is not intended in this technical manual to set forth the exact ranges to be covered by these instrument markings for all aircraft but to illustrate the correct method of marking the various types of instruments. For example, the manifold pressure gage (figure 7-6 detail A) shows a takeoff value of 49 inches; for one aircraft it might be 55 inches; for another it might be 72 inches; for another, 100 inches, and the like. The exact ranges to be covered on each instrument for a given aircraft can be determined only through reference to the instrument marking page of the appropriate -10 Operator's Manual.

7-44. MARKINGS FOR RECIPROCATING ENGINE AIRCRAFT

a. MANIFOLD PRESSURE GAGE. (See figure 7-6, detail A.)

(1) BLUE ARC. Indicates the range within which operation is permitted in auto-lean. The bottom of this arc indicates the minimum manifold pressure desirable in flight determined by engine characteristics. The top of this arc indicates the manifold pressure at which mixture control must be moved into auto-rich.

(2) GREEN RADIAL OR ARC. Describes the range within which operation must be in auto-rich. The radial or top of this arc indicates maximum continuous power. All operation above this manifold pressure is limited in time (usually 5 or 15 minutes).

(3) SHORT RED RADIAL.. Indicates manifold pressure for takeoff.

(4) LONG RED RADIAL. Indicates maximum dry war emergency manifold pressure.

(5) LONG RED RADIAL. Indicates maximum war emergency manifold pressure with water injection.

b. TACHOMETER. (See figure 7-6, detail B.)

(1) BLUE ARC. Indicates rpm range within which auto-lean, operation is permitted. The bottom of this arc indicates the minimum rpm desirable in flight because of engine limitations, generator cut-out, etc. The top of this arc indicates the rpm at which the mixture control must be moved to auto-rich.

(2) GREEN RADIAL OR ARC. Indicates rpm range within which auto-rich operation is required. The radial or top of this arc indicates maximum continuous power. All operation above this rpm is limited in time (usually 5 or 15 minutes).

(3) RED RADIAL. Indicates maximum rpm.

(4) RED ARC. May be used to show region of prohibited operation because of dangerous vibration or similar reasons.

c. CYLINDER HEAD TEMPERATURE GAGE. (See figure 7-6, detail C.)

(1) BLUE ARC. Indicates the range within which operation is permitted in auto-lean. The bottom of this arc indicates the minimum temperature desirable for flight (minimum engine warmth required for good fuel vaporization and efficient engine operation). The top of this arc indicates the temperature at which the mixture control must be moved to auto-rich.

(2) GREEN ARC. Describes the range within which operation must be in auto-rich. The top of this

arc indicates maximum continuous power; all operation above this temperature is limited in time (usually 5 or 15 minutes).

(3) RED RADIAL. Indicates maximum permissible temperature.

d. CARBURETOR AIR TEMPERATURE GAGE.

(See figure 7-6, detail D.)

(1) YELLOW ARC. Indicates the temperature range within which undesirable conditions may exist such as danger of icing or poor fuel vaporization.

(2) GREEN ARC. Indicates the temperature range of best operation and assures good vaporization.

(3) RED RADIAL. Indicates maximum permissible temperature, usually because of detonation danger.

e. COOLANT TEMPERATURE GAGE. (See figure 7-7, detail A.)

(1) GREEN ARC. Describes the range within which the temperature must remain during continuous operation. The bottom of this arc indicates minimum desirable temperature for flight. The top of this arc indicates maximum continuous power. All operation above this temperature is limited in time (usually 5 or 15 minutes).

(2) RED RADIAL. Indicates maximum permissible temperature.

(3) RED RADIAL. Indicates war emergency maximum temperature.

f. TORQUEMETER. (See figure 7-7, detail B.)

(1) BLUE ARC. Indicates the range within which operation is permitted in auto-lean. The bottom of this arc indicates the minimum torque pressure desirable in flight determined by engine characteristics. The top of this arc indicates the torque pressure at which mixture control must be moved into auto-rich.

(2) GREEN RADIAL OR ARC. Describes the range within which operation must be in auto-rich. The radial or top of this arc indicates maximum continuous power. All operation above this torque pressure is limited in time (usually 5 or 15 minutes).

(3) SHORT RED RADIAL. Indicates maximum dry torque pressure.

(4) LONG RED RADIAL. Indicates maximum wet torque pressure.

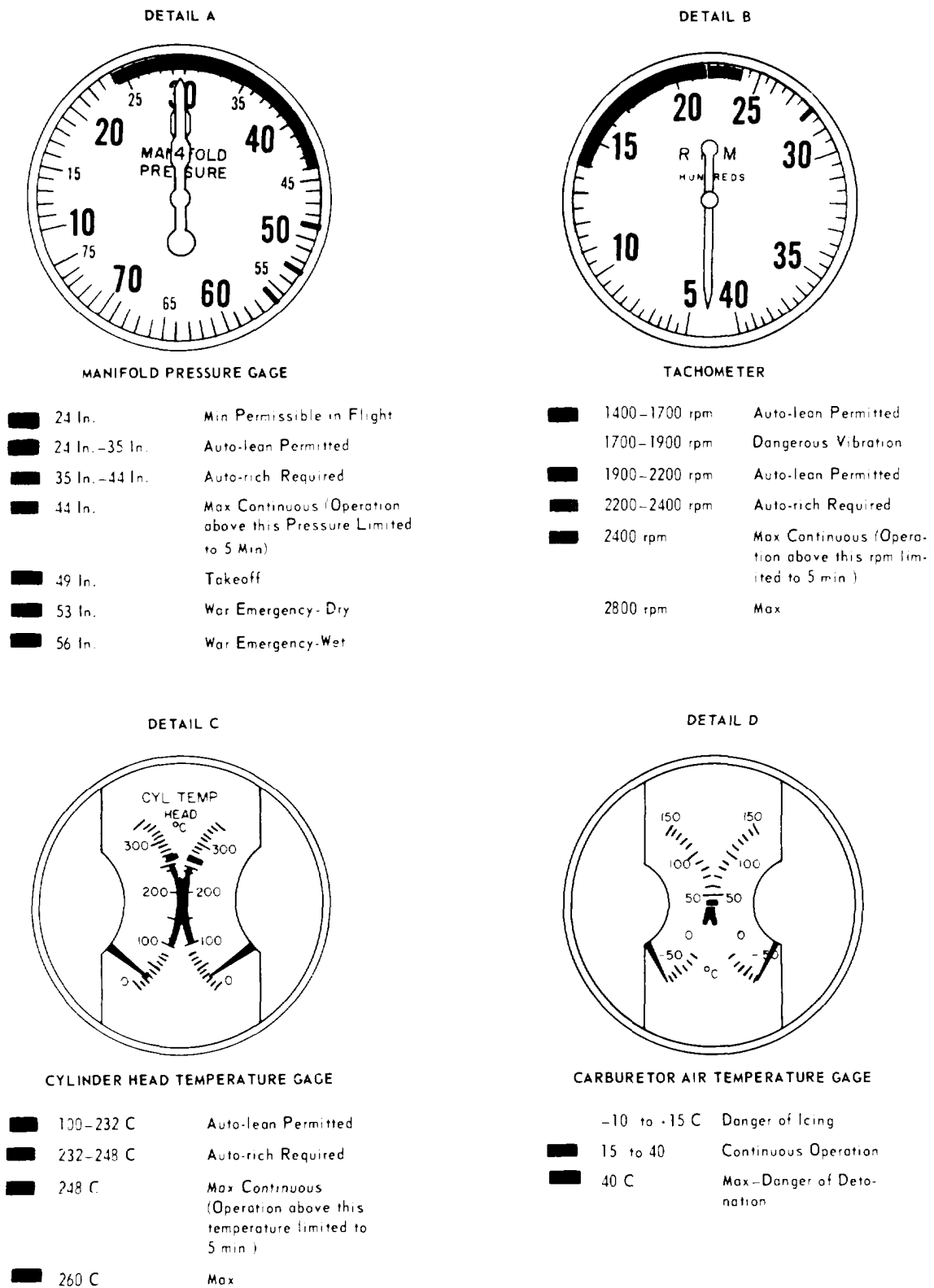
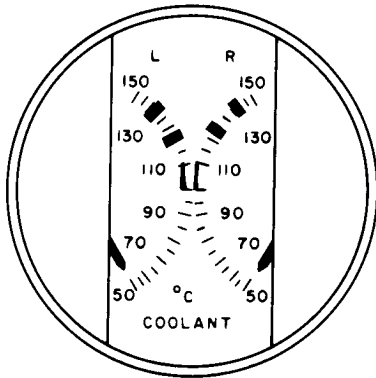


Figure 7-6. Typical Manifold Pressure Gage, Tachometer, Cylinder Head Temperature Gage, and Air Temperature Gage Markings.

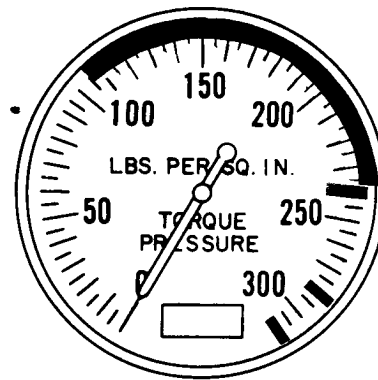
DETAIL A



COOLANT TEMPERATURE GAGE

100-110 C	Continuous Operation
125 C	Max
135 C	Max-War Emergency

DETAIL B



TORQUEMETER

120 psi	Min for Flight
120-240 psi	Auto-lean Permitted
240 psi	Max Continuous-A.L. or A.R. (Operation above this pressure limited to 5 min in A.R.)
280 psi	Max-Dry
300 psi	Max-Wet

Figure 7-7. Typical Coolant Temperature Gage and Torquemeter Markings

7-45. MARKINGS FOR JET ENGINE AIRCRAFT

a. TACHOMETER. (See figure 7-8, detail A.)

(1) GREEN ARC. Describes the range within which the rpm must fall during continuous flight operation. The bottom of this arc describes the minimum rpm for best cruising. Considerable range will be lost when operating below this rpm. The top of this arc indicates maximum continuous rpm; operation above which is limited to a specified length of time.

(2) RED RADIAL. Indicates maximum rpm.

(3) RED ARC. May be used to show region of prohibited operation because of dangerous vibration or similar reasons.

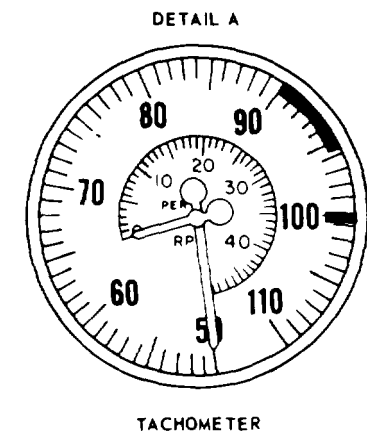
b. EXHAUST TEMPERATURE GAGE. (See figure 7-8, detail B.)

(1) RED RADIAL. Indicates minimum permissible temperature during flight.

(2) GREEN ARC. Indicates desirable temperature during continuous operation.

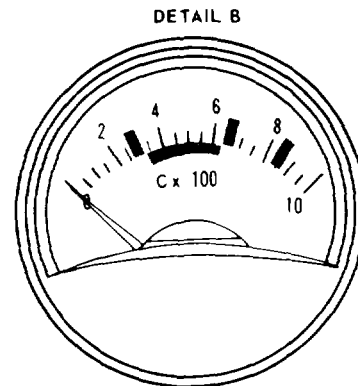
(3) RED RADIAL. Indicates maximum permissible temperature for flight.

(4) RED RADIAL. Indicates maximum permissible temperature during starting or acceleration.



TACHOMETER

90-96% Best Cruising
100% Max



EXHAUST TEMPERATURE GAGE

300 C Min for Flight
300 - 670 C Continuous Operation
670 C Max for Flight
850 C Max during starting and acceleration only

Figure 7-8. Typical Tachometer and Engine Exhaust Temperature Gage Markings

7-46. MARKINGS FOR HELICOPTERS

a. DUEL TACHOMETER. (See figure 7-9.)

(1) ROTOR.

(2) GREEN ARC. Indicates rotor rpm range during powered flight. The bottom of this arc describes minimum rotor rpm for continuous flight. The top of this arc indicates maximum rotor rpm with power.

(3) RED RADIAL. Indicates maximum permissible autorotative rpm.

(4) RED ARC OR RADIAL. May be used to show regions of prohibited operation because of dangerous vibration or similar reasons.

(5) ENGINE.

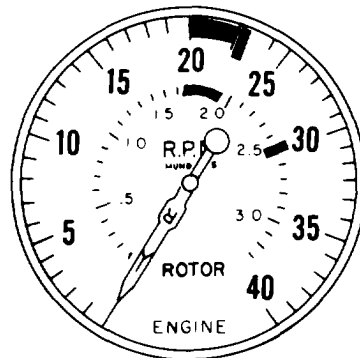
(6) RED RADIAL. Indicates maximum rpm.

b. NON CALIBRATED ROTOR SCALE. To locate a particular rotor speed on a universal type dual tachometer on which the rotor scale is not calibrated, use the following procedure.

(1) Find the speed on the engine scale corresponding to the desired rotor speed point by multiplying the desired rotor speed by the engine rotor gear ratio of the particular aircraft.




(2) Draw a line from the engine speed point on the engine scale, as determined above, to the center of the dial. The point where this line crosses the rotor scale is the desired rpm point on that scale.

(3) The above procedure can be used to locate any point on the rotor scale. The reverse of this procedure can be used to determine the rpm value of any point marked on the rotor scale.



DUAL TACHOMETER

ROTOR

	170 rpm	Min for Flight
	170-195 rpm	Continuous Power Operation
	245 rpm	Max Autorotation

ENGINE




	2100 rpm	Min for Flight
	2100-2300 rpm	Continuous Operation
	2300 rpm	Max

Figure 7-9. Typical Dual Tachometer Markings

7-47. MARKINGS FOR ALL AIRCRAFT

a. OIL PRESSURE GAGE. (See figure 7-10, detail A.)

(1) LOWER RED RADIAL. Indicates minimum oil pressure permissible in flight.

(2) GREEN ARC. Indicates desirable oil pressure range during continuous operation.

(3) UPPER RED RADIAL. Indicates maximum permissible oil pressure.

b. OIL TEMPERATURE GAGE. (See figure 7-10, detail B.)

(1) LOWER RED RADIAL. Indicates minimum permissible temperature during flight.

(2) GREEN ARC. Indicates desirable temperature during continuous operation.

(3) UPPER RED RADIAL. Indicates maximum permissible temperature.

c. AIRSPEED INDICATOR. (See figure 7-10, details C and D.)

(1) YELLOW RADIAL. Indicates maximum permissible airspeed with either full flaps or landing gear extended. When the maximum permissible speed with flaps down differs from that with gear down, the lower speed and condition will be given. A notation in parenthesis will also be included to show the higher limiting speed and condition.

(2) RED RADIAL. Indicates maximum permissible diving speed at design gross weight.

(3) YELLOW ARC. Defines the range of maximum permissible diving speeds from maximum to design gross weight.

d. ACCELEROMETER. (See figure 7-11, detail A.)

(1) RED RADIAL. Indicates maximum permissible positive acceleration at maximum gross weight.

(2) RED RADIAL. Indicates maximum permissible positive acceleration at design gross weight.

(3) RED RADIAL. Indicates maximum permissible negative acceleration at maximum gross weight.

e. HYDRAULIC PRESSURE GAGE. (See figure 7-11, detail B.)

(1) YELLOW RADIAL. Indicates pressure required for one brake application.

(2) GREEN ARC. Indicates normal operating pressure. The lower end of this arc indicates hydraulic pump cut-in pressure and the upper end indicates cut-out pressure.

(3) RED RADIAL. Indicates maximum permissible pressure.

f. SUCTION GAGE. (See figure 7-11, detail C.)

(1) RED RADIAL. Indicates minimum desirable suction.

(2) GREEN ARC. Indicates desirable suction range.

(3) RED RADIAL. Indicates maximum desirable suction.

g. DEICER GAGE. (See figure 7-11, detail D.)

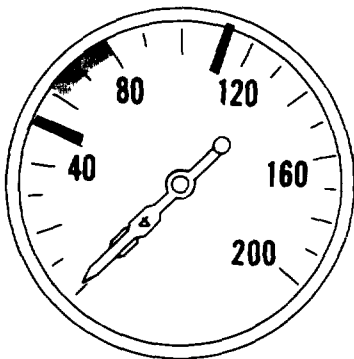
(1) GREEN ARC. Indicates desirable pressure range.

(2) RED RADIAL. Indicates maximum permissible pressure.

h. FUEL PRESSURE GAGE. (See figure 7-11, detail E.)

Same as oil pressure gage. (Refer to subparagraph a).

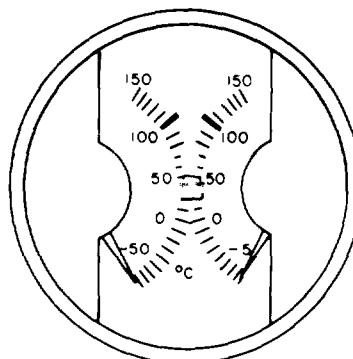
DETAIL A



OIL PRESSURE GAGE

- 50 psi Min for Flight
- 60-85 psi Continuous Operation
- 110 psi Max

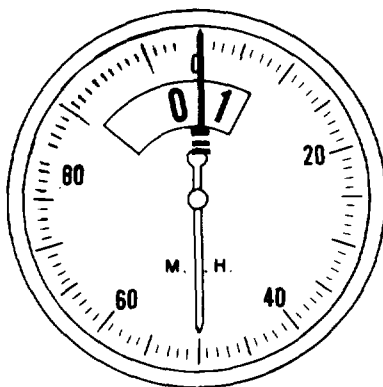
DETAIL B



OIL TEMPERATURE GAGE

- 40 C Min for Flight
- 60-75 C Continuous Operation
- 100 C Max

DETAIL C



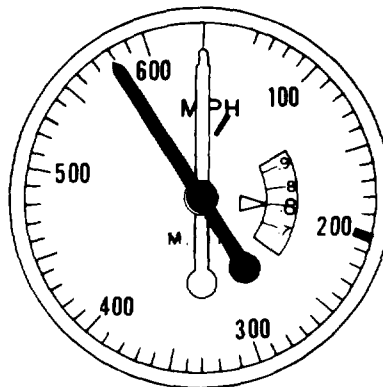
AIRSPEED INDICATOR

- 180 mph Full Flaps or Landing Gear
- 290-300 mph Max Diving (31000-26000 lb)
- 300 mph Maximum Diving

NOTE

Should the landing gear and flap limits differ, no change will be made to the instrument marking but the caption in the -10 Operator's Manual will be written as follows:
 180 mph Max-Full Flaps (Landing Gear-190 mph)

DETAIL D

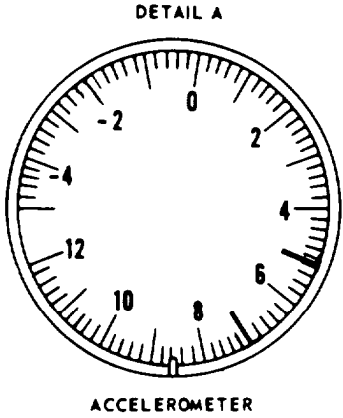


AIRSPEED INDICATOR

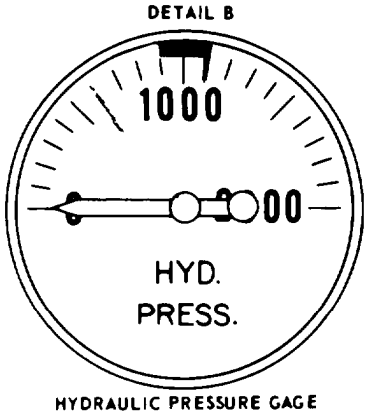
- 200 mph Full Flaps or Landing Gear

The instrument setting is such that the red pointer will move to indicate the limiting structural airspeed of 580 mph or the airspeed representing the limiting Mach. No. of .8, whichever is less.

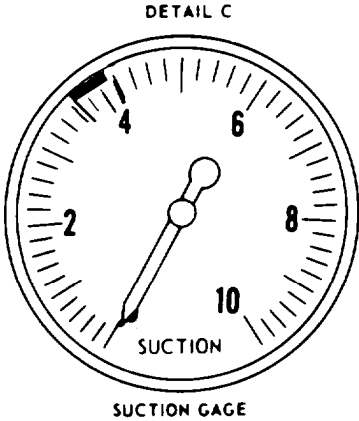
Figure 7-10. Typical Oil Pressure Gage, Oil Temperature Gage, and Airspeed Indicator Markings



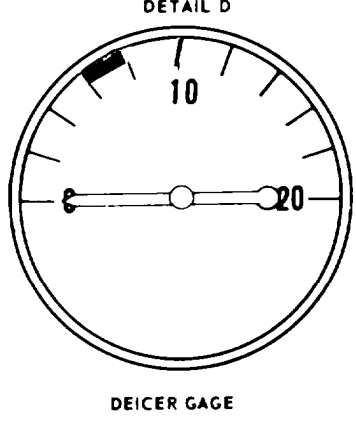
- 5 G Max at Max Gross Weight (with drop tanks)
- 7 G Max at design Gross Weight
- 2 G Max at Max Gross Weight (with drop tanks)



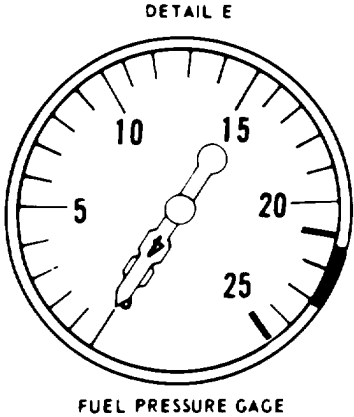
- 500 psi One Brake Applicat Remaining
- 900-1150 psi Normal
- 1150 psi Max



- 3.75 In. Hg Min
- 3.75-4.25 In. Hg Normal
- 4.25 In. Hg Max

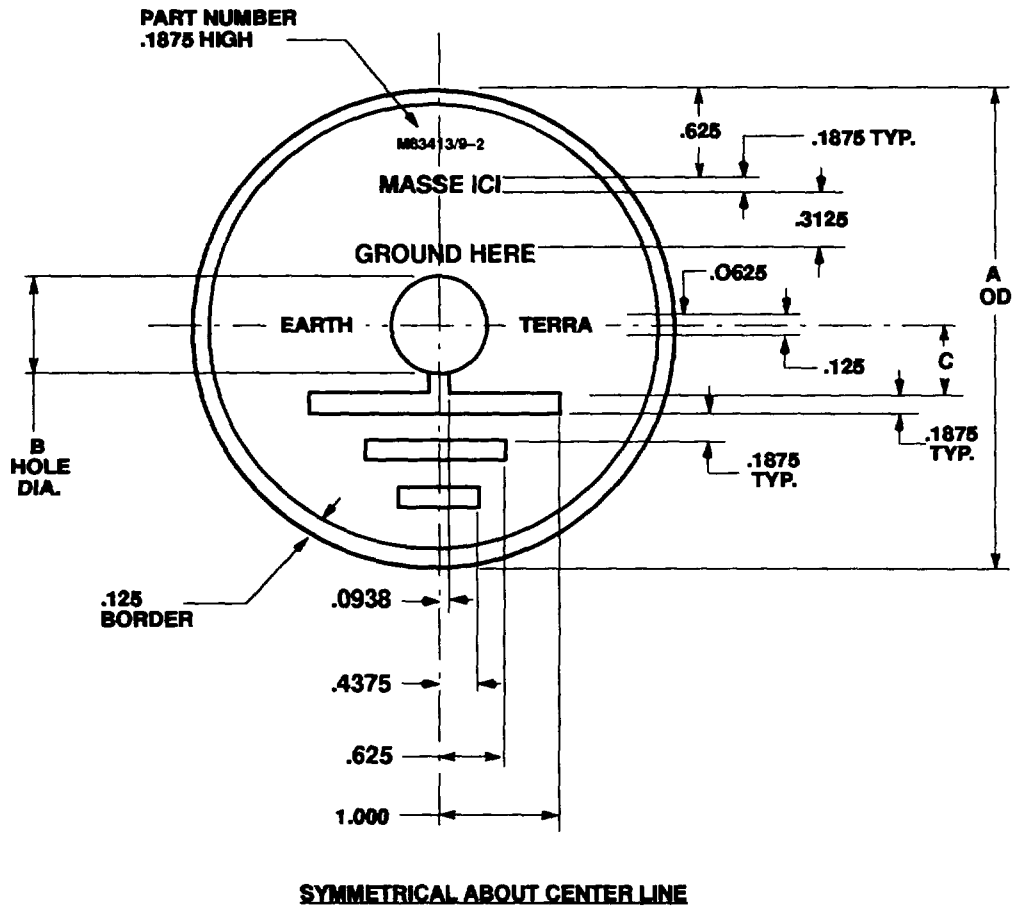


- 6-8 psi Normal
- 10 psi Max



- 21 psi Min for Flight
- 21-23 psi Normal
- 25 psi Max

Figure 7-11. Typical Accelerometer, Hydraulic Pressure Gauge, Deicer Gage, and Fuel Pressure Gage Markings.



NOTES:

1. DIMENSIONS ARE IN INCHES.
2. UNLESS OTHERWISE SPECIFIED, TOLERANCE IS $\pm .031$.

DASH NUMBER	A O.D.	B HOLE DIA.	C
-2	4.000 $\pm .125$	1.200 $\pm .125$.750 $\pm .125$

Figure 7-12. Fuel Nozzle Ground Dimensions.

CHAPTER 8

MISCELLANEOUS TABLES AND ILLUSTRATIONS

Table 8-1. Technical Manuals, Technical Bulletins, and AR's

TM 5-618	Painting, Repairs and Utilities
TB 55-9150-200-24	Engine and Transmission Oil, Fuels, and Additives for Army Aircraft
TM 1-1500-344-23	Aircraft Weapons Systems Cleaning and Corrosion Control
AR 200-1	Environmental Protection and Enhancement
CTB 43-0101	Handling, Storage and Disposal of Army Aircraft components containing Radioactive Materials
TB MED 501	Occupational and Environmental Health: Hearing conservation
TB MED 502	Occupational and Environmental Health: Respiratory Protection Program
TM 1-1500-204-23 (Series)	General Aircraft Maintenance Manual

Table 8-2. Standards

Federal Standard 595	- Colors
Military Standard 795	- Colors

Table 8-3. Consumable Items List

	Nomenclature	Specification	NSN	Quantity
1.	Acid, Chromic	O-C-303	6810-00-264-6517	5 lb can
2.	Alcohol, Ethyl	O-E-760	6810-00-201-0907	5 gal
3.	Barrier Material	MIL-B-131	8135-00-282-0565	200 yds
4.	Bicarbonate, Sodium	O-S-576	6810-00-264-6618	1 lb
5.	Brush, Long Handle, Non-Metallic	MIL-B-23958	7920-00-051-4384	Each
6.	Cloth, Abrasive, Aluminum Oxide, 180 grit	P-C-451	5350-00-192-5051	Sheet
7.	Cloth, Abrasive, Aluminum Oxide, 240 grit	P-C-451	5350-00-161-9715	Sheet
8.	Cloth, Abrasive, Aluminum Oxide, 320 grit	P-C-451	5350-00-246-0330	Sheet
9.	Cloth, Lint-Free	CCC-C-46	8305-00-753-2967	50 yds
10.	Coating, Compound, Metal Pretreatment	MIL-C-8514	8030-01-015-6104	1 gal kit
11.	Coating, Fluorescent Red-Orange Paint	MIL-P-21600	8010-00-082-2421	1 gal
12.	Coating Kit, Rain Erosion Resistant, CLA TY 11	MIL-C-83231	8010-00-459-1756	1 gal kit
13.	Coating, Polyurethane, Rain Erosion, Thermally Reflective	MIL-C-83445	8010-01-132-2976	1 gal kit
14.	Coating, Polyurethane, Olive Drab, No. 34088	MIL-C-46168	8010-01-055-2319	1 gal kit
15.	Coating, Polyurethane, Olive Drab, No. 34088	MIL-C-46168	8010-01-144-9875	5 gal kit
16.	Coating, Polyurethane. Aircraft Black. No. 37038	MIL-C-46168	8010-01-144-9879	5 gal kit

Table 8-3. Consumable Items List — Continued

	Nomenclature	Specification	NSN	Quantity
17.	Coating, Polyurethane. Aircraft Black. No. 37038	MIL-C-46168	8010-01-144-9885	1 qt
18.	Coating, Polyurethane. Aircraft Black. No. 37038	MIL-C-46168	8010-01-146-2646	1 gal
19.	Coating, Polyurethane. Aircraft Green. No. 34031	MIL-C-46168	8010-01-129-9348*	55 gal (Component A)
20.	Coating, Polyurethane. Aircraft Green. No. 34031	MIL-C-46168	8010-01-131-6255	1 gal
21.	Coating, Polyurethane. Aircraft Green, No. 34031	MIL-C-46168	8010-01-131-6262	5 gal
22.	Coating, Polyurethane. Aircraft Green. No. 34031	MIL-C-46168	8010-01-141-2420	1 qt
23.	Coating, Polyurethane. Aircraft Gray. Exterior. No. 36300	MIL-C-46168	8010-01-127-8908	1 gal
24.	Coating, Polyurethane. Aircraft Gray, Exterior, No. 36300	MIL-C-46168	8010-01-144-9876	5 gal
25.	Coating, Polyurethane. Orange/Yellow, No. 33538	MIL-C-46168		
26.	Coating, Polyurethane. Aircraft Gray, Exterior, No. 36300	MIL-C-46168	8010-01-144-9882	1 qt
27.	Coating, Polyurethane. Aircraft Gray, Interior, No. 36231	MIL-C-46168	8010-01-146-2649	1 gal
28.	Coating, Polyurethane. Aircraft Red. No. 31136	MIL-C-46168	8010-01-144-9873	1 gal
29.	Coating, Polyurethane. Aircraft Red, No. 31136	MIL-C-46168	8010-01-144-9878	5 gal
30.	Coating, Polyurethane, Aircraft Red, No. 31136	MIL-C-46168	8010-01-144-9884	1 qt

Table 8-3. Consumable Items List — Continued

	Nomenclature	Specification	NSN	Quantity
31.	Coating, Polyurethane, Aircraft White, No. 37875	MIL-C-46168	8010-01-144-9872	1 gal
32.	Coating, Polyurethane, Aircraft White, No. 37875	MIL-C-46168	8010-01-144-9877	5 gal
33.	Coating, Polyurethane, Aircraft White, No. 37875	MIL-C-46168	8010-01-144-9883	1 qt
34.	Coating, Polyurethane, Component B (for all 55 gallon drum kits)	MIL-C-46168	8010-01-132-0205**	55 gal
35.	Coating, Polyurethane, Dark Sand	MIL-C-46168		1 gal
36.	Coating, Polyurethane, Insignia Blue, No. 35044	MIL-C-46168	8010-01-144-9880	5 gal
37.	Coating, Polyurethane, Insignia Blue, No. 35044	MIL-C-46168	8010-01-144-9887	1 qt
38.	Coating, Polyurethane Insignia Blue, 35044	MIL-C-46168	8010-01-146-2648	1 gal
39.	DELETED			
40.	Coating, Walkway, Type II	MIL-W-5044	5610-00-641-0427	1 gal
41.	Compound, Sealing	MIL-S-7124	8030-00-024-9634	1 pt
42.	Dichloromethane	MIL-D-6998	6810-00-244-0290	5 gal
43.	Dichromate, Potassium	O-P-559	6810-00-264-6525	5 lb
44.	Ethylene, Glycol, Monoethyl Ether Acetate	MIL-E-7125	6810-00-263-0563	1 Gal can
45.	Films, Chemical, Corrosion Resistant for Aluminum, Class 1A	MIL-C-5541	8030-00-811-3723	2 lb can
46.	Foil, Metal, 5052 Aluminum Alloy	QQ-A-1-876	9535-00-541-2453	Roll

Table 8-3. Consumable Items Lists — Continued

	Nomenclature	Specification	NSN	Quantity
47.	Lacquer, Lusterless Black, Shade 37038	MIL-L-19538	8010-00-527-2884	1 gal
48.	Lacquer, Black	MIL-L-46159	8010-01-042-9438	1 gal
49.	Lacquer, Gray No. 36231	TT-L-20	8010-00-515-1568	1 gal can
50.	Lacquer, Cellulose Nitrate Aluminum, Shade 17178	TT-L-32	8010-00-241-8406	1 gal
51.	Lacquer, Gray Shade 36231	TT-L-20	8010-00-515-1568	1 gal
52.	Lacquer, Lusterless Aircraft Green	MIL-L-46159	8010-00-083-6588	5 gal can
53.	Lacquer, Lusterless Aircraft Green	MIL-L-46159	8010-01-033-8917	1 gal
53.1	Lacquer, Acrylic, Blue Shade 15044	MIL-L-19537	8010-00-551-7933	1 Gal
53.2	Lacquer, Acrylic, Green Shade 14187	MIL-L-19537	8010-00-527-2483	1 Gal
53.3.	Lacquer, Acrylic, Red Shade 11136	MIL-L-19537	8010-00-551-7934	1 Qt
53.4.	Lacquer, Acrylic, Yellow Shade 13538	MIL-L-19537	8010-00-527-2496	1 Qt
54.	Mat, Abrasive Nylon	MIL-A-9962	5350-00-967-5089	Sheet
55.	Methyl Ethyl Ketone	TT-M-261	6810-00-281-2785	1 gal
56.	Paint, Epoxy, Gray, No. 36231	MIL-C-22750	8010-01-082-3060	1 qt
57.	Paper, Abrasive, No. 400	P-P-101	5350-00-224-7201	Sheet
58.	Paper, Abrasive, 280 Grit	P-P-105	5350-00-264-3489	Sheet
59.	Primer, Lead and Chromatic Free	MIL-P-85582	8010-01-218-0857	1 gal kit
60.	Paper, Barrier, Grade A, Type 1, Class 2	MIL-B-121	8135-00-753-4661	Roll

Table 8-3. Consumable Items List - Continued

	Nomenclature	Specification	NSN	Quantity
61.	Deleted.			
62.	Primer. Red	MIL-P-52192	8010-00-082-1714	5 qt kit
63.	Primer. Wash	DOD-P-15328	8030-00-281-2726	1 gal kit
64.	Corrosion Preventive Compound, Petrolatum Hot Application, Grade 1	MIL-C-11796	8030-00-285-1570	35 lb pail
65.	Corrosion Preventive Compound, Solvent Cutback Cold Application, Grade 1	MIL-C-16173	8030-00-231-2345	1 gal
66.	Remover. Paint	MIL-R-25134	8010-00-815-2970	1 gal
67.	Remover. Paint. Type I	MIL-R-81294	8010-00-181-7568	1 gal
68.	Sealant. Class B	MIL-S-8784	8030-00-152-0021	8 oz
69.	Sealant. Safety Walk. Pressure Sensitive Material. Type III.	MIL-D-17951	8030-00-264-3886	5 oz
70.	Sealant. Type II. Class A	MIL-S-8802	8030-00-842-8127	1 gal
71.	Sealing Compound Class B	MIL-S-8802	8030-00-753-4597	1/2 pt
72.	Sealing Compound Class B	MIL-S-7124	8030-00-024-9634	1 pt
73.	Sheet. Plastic. Laminated Type ADP. .062 Thick	L-P-387A	9330-00-282-5640	Sheet
74.	Solvent. Dry Cleaning	P-D-680	6850-00-285-8011	55 gal
75.	Solvent. Ethyl Acetate	TT-E-751	6810-00-245-6694	5 gal
76.	Tape. Insulation	MIL-I-15126	5970-00-137-9501	Roll
77.	Tape. Masking	PPP-T-42	7510-00-266-6712	60 yd roll
78.	Tape. Pressure Sensitive	MIL-T-21595	7510-00-680-2395	2" wide roll
79.	Tape. Pressure Sensitive Adhesive.	PPP-T-60	7510-00-281-2700	3" wide roll

Table 8-3. Consumable Items List - Continued

Nomenclature	Specification	NSN	Quantity
90. Tape, Pressure Sensitive Adhesive, Type II	MIL-T-23397	7510-00-473-9513	2" wide roll
80.1. Tape, Pressure Sensitive, Blue	A-A-113	7510-00-550-7124	1/2 X 2592 in roll
80.2. Tape, Pressure Sensitive, Green	A-A-113	7510-00-550-7129	1/2 X 2592 in roll
80.3. Tape, Pressure Sensitive, Red	A-A-113	7510-00-550-7126	1/2 X 2592 in roll
80.4. Tape, Pressure Sensitive, Yellow	A-A-113	7510-00-550-7125	1/2 X 2592 in roll
80.5. Tape, Pressure	A-A113	7510-00-550-7127	
80.6. Tape, Reflective, Yellow	L-S-300	9390-00-057-4545	50 yd roll
80.7. Tape, Reflective, Green	L-S-300	9390-00-106-2466	50 yd roll
80.8. Tape, Reflective, Red	L-S-300	9390-00-106-2467	50 yd roll
81. Thinner	MIL-T-6096	8010-00-165-5582	1 gal
82. Thinner, Aliphatic Polyurethane Coating	MIL-T-81772	8010-00-181-8080	1 gal
83. Thinner, Lacquer	TT-T-266	8010-00-160-5787	1 gal
84. Toluene	TT-T-548	6810-00-290-0048	5 gal
85. Xylene	ASTM D 846	6810-00-584-4070	5 gal
86. Deleted			
87. Urethane, Gloss	MIL-C-83286	Local Purchase ***	
88. Varnish, Acid-Proof	TT-V-51	8010-00-160-5856	5 gal
89. Wax, Paraffin	VV-W-95	9160-00-285-2044	1 lb cake
90. Wool, Aluminum	MIL-A-4864	5350-00-286-4851	1 lb

Table 8-3. Consumable Items List - Continued

	Nomenclature	Specification	NSN	Quantity
91.	Litmus, Paper AC (Blue)	MS 36253-2	6640-00-290-0146	100 ea
92.	Litmus, Paper AC (Red)	MS 36253-1	6640-00-290-0147	100 ea
93.	Paint Heat Resistant, Gray	MIL-P-14105	8010-00-877-6415	1 gal
94.	Lacquer, Aluminum, Heat Resisting, Shade 17178	TT-P-28	8010-00-815-2592	1 gal
95.	Paint, Heat Resisting Shade 34087	MIL-P-14105	8010-00-616-4009	1 gal
96.	Epoxy Primer Coating	MIL-P-53022	8010-01-193-0516	1 qt kit
97.	Coating Polyurethane aircraft green, No. 34031	MIL-C-46168 TY4	8010-01-316-2219	1 gal
98.	Coating Coating Polyurethane aircraft black, No. 37038	MIL-C-46168 TY4	8010-01-340-5176	4 gal
99.	Coating Polyurethane aircraft yellow, No. 33538	MIL-C-46168 TY4	8010-01-247-8885	1 qt
100.	Coating Polyurethane tan, No. 33446	MIL-C-46168 TY4	8010-01-306-9680	1 gal
101.	Primer Coating, epoxy	MIL-P-53030	8010-01-193-0520	1 gal

* 55 gallon drums Component A: If these NSNs are used, order four, and one 55-gallon drum of Component B will also be shipped. This is consistent with the mixing ratio required of 4 (Component A) to 1 (Component B).

* Component B.

*** Although Olive Drab is not listed in the Military Specification or Qualified Products List (QPL), it is available from the companies listed on the QPL.

Table 8-4. State Abbreviations

Alaska	AK	Montana	MT
Alabama	AL	Nebraska	NE
Arizona	AZ	Nevada	NV
Arkansas	AR	New Hampshire	NH
California	CA	New Jersey	NJ
Colorado	CO	New Mexico	NM
Connecticut	CT	New York	NY
Delaware	DE	North Carolina	NC
District of Columbia	DC	North Dakota	ND
Florida	FL	Ohio	OH
Georgia	GA	Oklahoma	OK
Guam	GU	Oregon	OR
Hawaii	HI	Pennsylvania	PA
Idaho	ID	Puerto Rico	PR
Illinois	IL	Rhode Island	RI
Indiana	IN	South Carolina	SC
Iowa	IA	South Dakota	SD
Kansas	KS	Tennessee	TN
Kentucky	KY	Texas	TX
Louisiana	LA	Utah	UT
Maine	ME	Vermont	VT
Maryland	MD	Virginia	VA
Massachusetts	MA	Virgin Islands	VI
Michigan	MI	Washington	WA
Minnesota	MN	West Virginia	WV
Mississippi	MS	Wisconsin	WI
Missouri	MO	Wyoming	WY

Table 8-5. Definitions of Common Painting Terms

Common Painting Terms	Definitions
Abrasion Resistance	The resistance of a surface to being worn by rubbing or friction.
Acrylic	A family of synthetic resins made by polymerizing esters of acrylic acids.
Aliphatic	The name applied to petroleum products which are straight-chain hydrocarbons derived from a paraffin-base crude oil.
Alkyd	Asynthetic resin which is the condensation product of a Polybasic acid such as phthalic, a polyhydric alcohol such as glycerin and an oil fatty acid.
Alligatoring	A form of paint failure in which cracks form on the surface layer only. It is caused by the application of thick films where the underlying surface remains relatively soft.
Binder	The nonvolatile portion of a coating vehicle which is the film-forming ingredient used to bind the pigment particles together.
Bleeding	A condition which exists when the color of a dye, stain or pigment passes through the top coat producing a stain. It occurs when the pigment is somewhat soluble in the vehicle of the top coat.
Blistering	A paint film failure usually caused by application of paint on a surface containing an excessive amount of moisture or other volatile material.
Blushing	A term applied to lacquers when they become partially opaque, cloudy or translucent upon application or drying. Fast-evaporating solvents may cool the film enough to cause water condensation, and resultant precipitation of solid materials.
Catalyst	A substance which accelerates the speed of a chemical reaction.
Chalking	The presence of a loose powder on the surface of a paint after exposure to the elements.
Checking	A phenomenon manifested by slight breaks in the surface of the paint film.
Coalescence	The fusing together of a latex film upon evaporation of water.
Cobwebbing	Same as webbing - see webbing.

Table 8-5. Definitions of Common Painting Terms — Continued

Common Painting Terms	Definitions
Color	<p>A generic term referring inclusively to all colors of the spectrum, and white and black. Color is described by three properties: hue, lightness and saturation.</p> <p>(1) Hue (color, character, dominant wavelength), blue, green, red, etc.</p> <p>(2) Lightness (brightness, reflectance, value) position on the gray scale between pure black and pure white.</p> <p>(3) Saturation (purity, grayness, cleanliness, muddiness, chroma), purity or intensity of color.</p>
Color Retention	Color stability after exposure to the elements.
Compatibility	The ability of two or more materials to mix with each other without separation or adverse reaction.
Corrosion	Detrimental change in a material usually a metal under condition of exposure.
Crawling	The tendency of a liquid to draw up because of high surface tension.
Crocking	Removal of color on abrasion or rubbing.
Defoamer	Products used for controlling undesirable foams.
Dew Point	The temperature at which the air becomes saturated with water vapor.
Diluent	A liquid which is blended with an active solvent to reduce cost.
Drier	Any catalytic material which when added to a drying oil accelerates drying or hardening of the film.
Dry Bulb Temperature	The temperature as indicated by an ordinary thermometer.
Efflorescence	A phenomenon whereby a whitish crust of fine crystals forms on a painted surface. These are usually sodium salts which diffuse through the paint film from the substrate.

Table 8-5. Definitions of Common Painting Terms — Continued

Common Painting Terms	Definitions
Elastomeric Compound	Any of a variety of elastic compounds resembling rubber. Rubber is an elastomeric compound.
Emulsifier	A material which when added to a mixture of dissimilar materials such as oil and water will produce a stable homogeneous emulsion.
Emulsion	A suspension of fine particles of globules of a liquid within a liquid.
False Body	A composition which thins down on stirring is said to exhibit false body.
Faying Surfaces	Surfaces fitted or joined closely or tightly.
Firepoint	The temperature at which a material takes fire without flame from an external source.
Flash Point	Lowest temperature at which a substance in an open vessel gives off enough vapors to produce a flash of fire when a flame is passed near the surface.
Hue	Color, character, dominant wavelength, blue, green, red, etc.
Hydrogen Embrittlement	Embrittlement of a metal caused by absorption of hydrogen.
Hydrophilic	Attracted by water or water loving.
Hydrophobic	Repelled by water or water hating.
Hygroscopic	Absorbs and retains moisture from atmosphere or other sources.
Immiscible	Not miscible. Any liquid which will not mix with another liquid, in which case it forms two separate layers or exhibits cloudiness or turbidity.
Incompatible	This term is applied to liquid and solid systems to indicate that one material cannot be mixed with another specified material without separation or impairment of properties.
Inert	The term applied to various extended pigments such as asbestine, barytes, silica calcium sulfate, mica, talc, etc. In general, they have poor hiding power but they are inert from a chemical and physical standpoint. While they contribute some desirable properties to a paint, they are primarily used to lower the cost.

Table 8-5. Definitions of Common Painting Terms — Continued

Common Painting Terms	Definitions
Inhibitor	Any substance which slows or prevents chemical reaction or corrosion.
Intensity	The intensity of a color is its purity or saturation. For example, an intense red is one which is a very strong, pure red color.
Lacquer	A term which usually indicates that the material dries by evaporation and forms a film from the nonvolatile constituents.
Lightness	(Brightness, reflectance, value) Position on the gray scale between pure black and pure white.
Lipophilic	Oil loving.
Livering	An increase in the consistency of a paint resulting in a rubbery or coagulated mass.
Luster	The gloss of a finish.
Mildew	Organic surfaces exposed to high temperature-humidity atmospheres are attacked by fungus growth. This is a dark discoloration. Usually a mold type of fungus but more commonly called "mildew".
Mineral Spirits	A petroleum fraction with boiling range between 300° and 400°F.
Mottling	A film defect associated with spraying. Appears as circular imperfections.
Nitrocellulose	A substance produced by the treatment of cotton or wood fibers with nitric acid. Used in lacquers.
Opaque	Impervious to light or not translucent.
Orange Peel	A pebbled film surface similar to the skin of an orange in appearance. It is caused by too rapid drying before leveling takes place.
Organic	A compound containing carbon and hydrogen and in some cases other elements such as oxygen, nitrogen, sulfur, phosphorus, the halogens, etc.
Pastel	A tint. A color to which white has been added.

Table 8-5. Definitions of Common Painting Terms — Continued

Common Painting Terms	Definitions
PH Value	The numerical expression used to describe the hydrogen ion concentration. The PH value denotes the degree of acidity or alkalinity.
Phenolic Resins	A class of resins produced as the condensation product of phenol or substituted phenol and formaldehyde or derivatives.
Pigment	A finely divided, insoluble substance which imparts color to the material to which it is added.
Pigment Volume Concentration	The ratio of the total volume of pigment to the total volume of non-volatile matter in a paint.
Pinholing	The appearance of fine, pimply elevations or tiny holes on a coating.
Plasticizers	Materials which are added to resins to soften and improve flexibility.
Polymer	A large molecule formed when many molecules are linked together by polymerization.
Primary Colors	In theory, those colors from which all other colors and white may be made. The primary colors in visible light are red, green, and blue. The so-called pigment primaries, each absorbing a light primary, would then be blue green or cyan (minus red), majenta (minus green), and yellow (minus blue). Because of deficiencies in the available cyan and majenta colorants, confusion developed, so that red, yellow and blue are now often referred to as the pigment primaries.
Reducer	A volatile compound which is employed to bring coatings to the proper consistency. Also called thinner.
Reflective Index	A measure of the deviation from normal that a beam of light undergoes upon passing through a given substance.
Relative Humidity	A method for expressing the amount of moisture in the air. It is expressed in per cent of saturation and is an indication of the proportional amount of moisture that could be absorbed or held at that temperature.
Resin	An organic polymer in the form of a crystalline or amorphous solid, or viscous liquid, of either natural or synthetic origin.
Sagging	The tendency of a wet paint film to flow downward and become thicker on vertical surfaces.

Table 8-5. Definitions of Common Painting Terms — Continued

Common Painting Terms	Definitions
Saturation	Purity or intensity of color. Degree of freedom from grayness.
Seeds	Undesirable particles which develop in a liquid coating by partial gelation of the vehicle or by agglomeration of pigment particles.
Shade	The difference in appearance between colors of similar hue.
Sheen	A specular reflectance taken at a low angle, usually 85°.
Skinning	The formation of a solid surface layer on a liquid varnish or paint when exposed to air.
Solution	A homogeneous liquid mixture, the proportion of whose constituents may be varied within certain limits. A solid is said to be in solution when the molecules of the liquid have exceeded the attraction of those of the solid.
Solvent	The term applied to products which dissolve the film forming constituents.
Specific Gravity	The ratio of the weight of an equal volume of a substance to the weight of an equal volume of water at stated temperature.
Spreading Rate	The area of a surface over which a unit volume of paint will spread; usually expressed in square feet per gallon.
Strength	The strength of a pigment is its opacity or tinting power.
Substrate	The basis metal.
Tint	A color produced by mixing a colored material, dye or pigment with white pigment or paint.
Tinting Strength	The coloring power of a given quantity of pigment or paint.
Tone	A modification of a full-strength color (mass tone) secured by blending with other colors.
Toughness	The ability of a material to take bending, impact, etc. without cracking.
Vehicle	The liquid portion of any paint, enamel or lacquer.

Table 8-5. Definitions of Common Painting Terms — Continued

Common Painting Terms	Definitions
Viscometer	Any instrument that measures viscosity or the internal friction of fluidity of a liquid.
Viscosity	A property of fluids which can be described as the resistance to flow.
Webbing	A stringy paint deposit similar to that of a spider web.
Wrinkle Finish	A varnish or enamel film which exhibits a novelty effect similar to fine wrinkles.

Table 8-6. Ventilation and Respirator Requirements for Application of Paints

Facility	Air Flow (CFM/Sq Ft Open Face Area, FPM)*	Respirator
Walk-in room or deep booth (crossdraft up to 50 FPM)#	<75	Airline
(crossdraft up to 100 FPM)	<125	Airline
(crossdraft up to 50 FPM)	>75	Chemical Cartridge
(crossdraft up to 100 FPM)	>125	Chemical Cartridge
Spray cabinets (less than 4 sq ft. open face area) (crossdraft up to 100 FPM)	<150	Airline
	>150	Chemical Cartridge
Spray cabinet (more than 4 sq ft open face area) (crossdraft up to 100 FPM)	<125	Airline
	>125	Chemical Cartridge
Confined spaces (for example inside or under- neath vehicles or other equipment)		Airline
Outdoor application Brush or roller application		Chemical Cartridge
Spray application		Airline
Indoor application	No mechanical ventilation	Airline

* Cubic feet per minute per square foot of open face area (CFM/sq ft) is equivalent to feet per minute (FPM). CFM is a volumetric flow rate; FPM is a linear flow rate. Values listed are the minimum allowed.

(< – less than, > – greater than)

+ Respirator — Airline means NIOSE/MSEA-approved Type C positive pressure device with a full facepiece.

— Chemical cartridge means a NIOSE/MSEA-approved paint spray respirator with organic vapor cartridge(s), paint prefilter(s), full facepiece.

— Chemical cartridges and paint spray prefilters shall be changed with appropriate replacement elements based on the following:

— Daily

— When breakthrough (solvent odor) is detected by the wearer

— When breathing resistance is too great

Crossdrafts greater than 100 FPM should not be permitted.

TABLE 8-7. Current Safety Guidelines for Application of MI L-C-46168B Paint

Type Of Painting Facility	Maximum Crossdraft (Feet per Minute) ^b	Application Safety Procedures					
		Minimum Cross-Section Air Flow Velocity (Feet per Minute) ^b					
		25	50	75	100	125	150
Walk-in Room or Deep Booth (e. g., Vehicular Booth)	50	Airline Respirator ^c			Chemical Cartridge Respirator		
	100	Airline Respirator ^c			Chemical Cartridge Respirator		
Spray Cabinet (Less Than 4 ft ² Open Face Area)	100	Airline Respirator ^c				Chemical Cartridge Respirator	
Spray Booth (More Than 4 ft ² Open Face Area)	100	Airline Respirator ^c				Chemical Cartridge Respirator	
Confined Spaces (e.g., Inside or Underneath Vehicle)	—	Airline Respirator ^c					
Outdoor application	—	Chemical Cartridge Respirator ^d					
— Spray	—	Airline Respirator ^c					
Indoor Application (No Validation)	—	Airline Respirator ^e / Facility Dedication/No Unprotected Personnel ^f					

^a Worker protection also includes full skin cover clothing and gloves. exclusion of sensitized personnel and job-related medical surveillance.

^b Feet per minute = ft³/min/ft² of open face area perpendicular to air flow.

^c Airline respirator = NIOSH/MSHA-approved Type C positive-pressure airline hose mask with full face-piece.

^d Chemical cartridge respirator = NIOSH/MSHA-approved paint spray respirator with organic vapor cartridge(s), paint/mist prefilter(s), and full facepiece. Cartridges and prefilters are to be replaced when one of the following occurs:

- new workday begins
- chemical or solvent odor is detected inside mask by wearer
- breathing resistance becomes too great

^e Unprotected personnel should remain outside a 50-ft radius until 30 minutes after painting is completed.

^f Exclusion of unprotected personnel during painting and for 30 minutes after cessation of painting.

Table 8-8. Recommended Respiratory Protection Guidelines for Spray Finishing Operations

Facility	Air Flow, CFM/Sq Ft Cross Section (FPM)*		
	Compressed Air Spray	Airless Spray	Electrostatic Coating
Walk-in Room or Deep Booth (Example—Vehicular Booth)	75-100	60	—
Spray Cabinet (Less Than 4 sq. ft. Open Face Area)	150	100	100
Spray Booth (More Than 4 sq. ft. Open Face Area)	200	125	100
Confined Spaces (Example—Inside or Underneath Vehicle)	— Positive Pressure Air Line Respirator —		

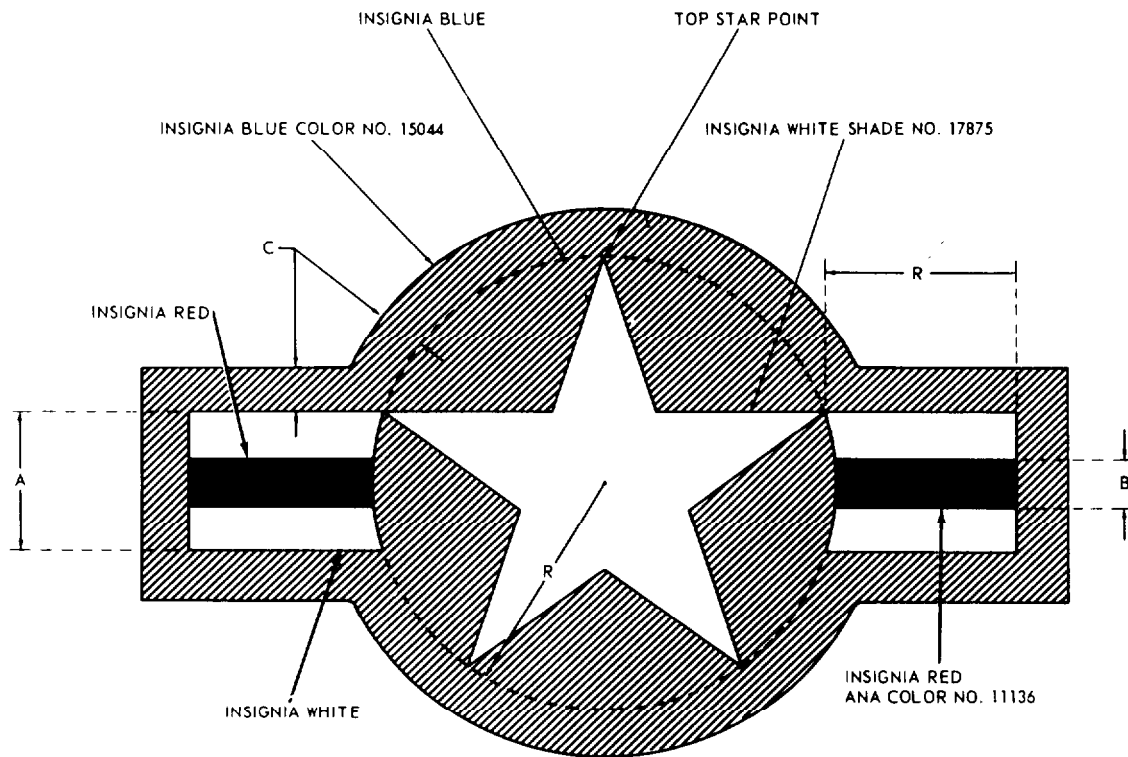
•Approved Organic Vapor Cartridge/Paint Spray Respirator and Eye Protection is Normally Required

Table 8-9. Occupational Health Protection Requirements for Paint Spray Workers Using MI L-E-52798A Alkyd Enamel and MIL-C-46168B Polyurethane Coating

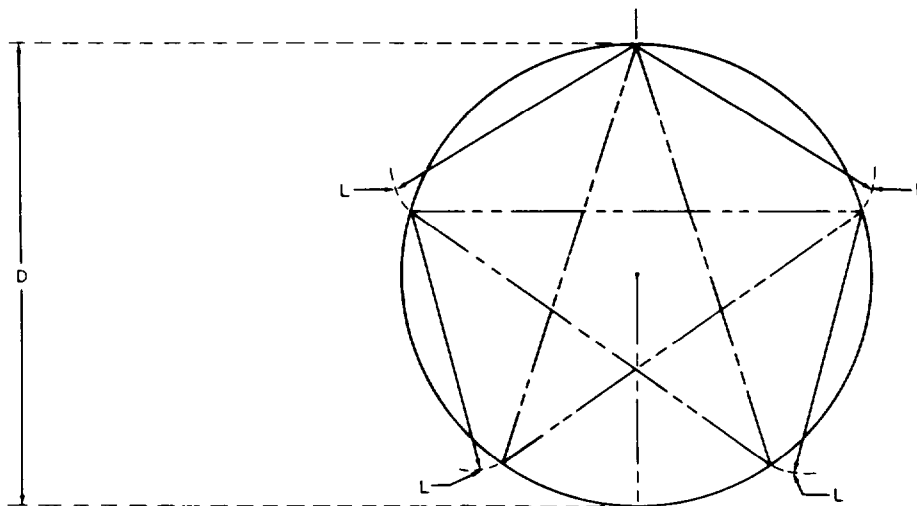
	Alkyd Enamel and Lacquer	Polyurethane Coating
Hazards	Pigments (May Include Pb and CrO ₃)	Pigments (May Include Pb and CrO ₃)
	Driers	Isocyanates
	Solvent	Solvents
Recommended Protection	Ventilation Control	Ventilation Control
	Paint Spray Respirator* or Supplied Air-mask	Paint Spray Respirator* I or Supplied-Air Mask
	Eye Protection*	Eye Protection
		Medical Evaluation
Basis for Recommendations	OSHA Standards	OSHA Standards
	NIOSH Recommended Standards	NIOSH Recommended Standards
	ACGIH Recommendations	ACGIH Recommendations
	ANSI Standards	ANSI Standards
	Industry Practice	Industry Practice

* Depending on Concentration of Overspray.

** Pending Outcome of Tests to Determine Suitability and Depending on Concentration of Overspray.



THE RADIUS (R) OF THE BASIC BLUE CIRCLE DETERMINES ALL DIMENSIONS.



SUGGESTED CONSTRUCTION FOR TEMPLATES OR STENCILS

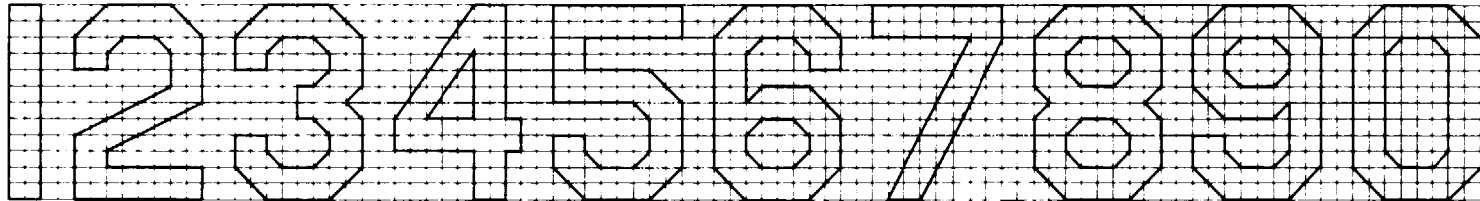
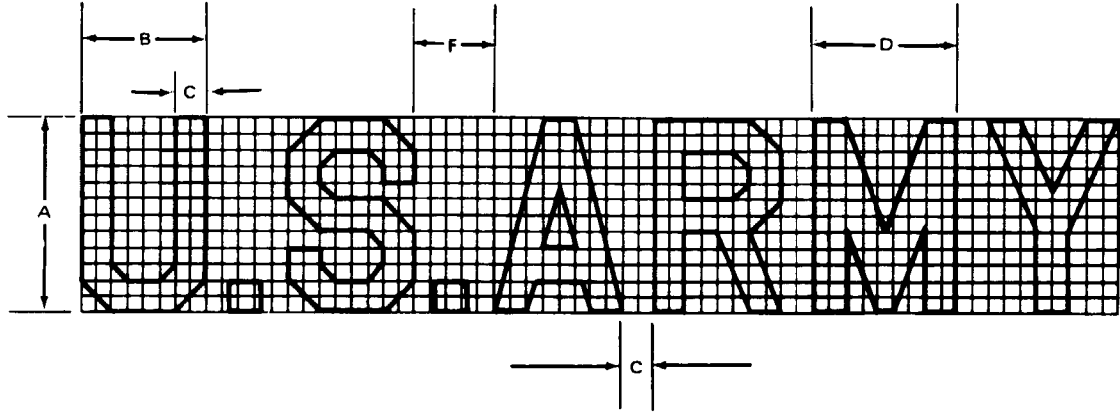
Figure 8-1. National Star Insignia (sheet 1 of 2)

D	R	A	B	c	L
9.5	4.75	2.375	0.80	0.59	5.6
10.0	5.00	2.500	0.83	0.63	5.9
15.0	7.50	3.750	1.25	0.94	8.8
20.0	10.00	5.000	1.66	1.25	11.8
25.0	12.50	6.250	2.08	1.56	14.77
30.0	15.00	7.500	2.50	1.88	17.6
35.0	17.50	8.750	2.92	2.19	20.6
40.0	20.00	10.000	3.33	2.50	23.5
45.0	22.50	11.250	3.75	2.81	26.5
50.0	25.00	12.500	4.17	3.13	29.4
55.0	27.50	13.750	4.58	3.44	32.3
60.0	30.00	15.000	5.00	3.75	35.3

* Note: 1. **All** Dimensions in Inches.






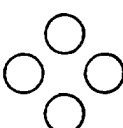

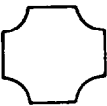
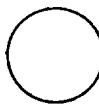
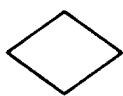




2. D = DIAMETER OF BASIC BLUE CIRCLE
 R = RADIUS OF BASIC BLUE CIRCLE 1/2D
 A = 1/2 RADIUS
 B = 1/6 RADIUS
 C = 1/8 RADIUS
 L = 1.176 RADIUS

Figure 8-1. National Star Insignia (sheet 2 of 2)





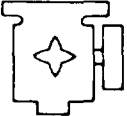
- A = HEIGHT OF LETTERS TO BE AS SPECIFIED IN CHAPTER 7, SECTION I
- B = WIDTH OF LETTERS TO BE $\frac{2}{3}$ THE LETTER HEIGHT
- C = STROKE AND SPACE BETWEEN LETTERS TO BE $\frac{1}{6}$ THE LETTER HEIGHT
- D = THE WIDTH OF THE LETTERS M AND W TO BE $\frac{3}{4}$ OF THE HEIGHT
- E = WIDTH OF LETTER I AND NUMERAL 1 TO BE $\frac{1}{6}$ OF HEIGHT
- F = DISTANCE BETWEEN WORDS TO BE $\frac{2}{3}$ LETTER HEIGHT


Figure 8-2. Wing and Fuselage Marking (Typical)

FILLING COLOR-BLACK OR WHITE ACCORDING TO BACKGROUND			
<p>1 REFUELING</p> <p>FILLED FOUR POINTED STAR WITH NOTATION OF NATO CODE NUMBER FOR FUEL AND MAXIMUM FILLING PRESSURE IN ENGLISH AND METRIC SYSTEMS</p>	 NATO CODE NO. MAX FILLING PRESSURE ___ PSI ___ Kg/Cm ²	<p>2 OXYGEN (BREATHING)</p> <p>TWO HORIZONTALLY FILLED RECTANGLES WITH NOTATION OF FILLING PRESSURE IN ENGLISH AND METRIC SYSTEMS. FOR LIQUID SYSTEMS THE WORD "LIQUID" SHALL BE USED INSTEAD OF "GAS" AND THE CAPACITY IN LITERS SHALL BE ADDED</p>	 GAS FILLING PRESSURE ___ PSI ___ Kg/Cm ²
<p>3 ROCKET FUELS</p> <p>FILLED FOUR POINTED STAR IN CRESCENT WITH NOTATION OF NATO CODE NUMBER FOR ROCKET FUEL AND MAXIMUM FILLING PRESSURE IN ENGLISH AND METRIC SYSTEMS</p>	 NATO CODE NO. MAX FILLING PRESSURE ___ PSI ___ Kg/Cm ²	<p>4 ANTIDETONANT OR THRUST AUGMENTATION</p> <p>FILLED WITH CHEVRON WITH NOTATION OF NATO CODE NUMBER AND PERCENTAGES</p>	 METHANOL % .. WATER % .. NATO CODE NO. (METHANOL CODE NO. S-747)
<p>5 ROCKET OXIDIZERS</p> <p>FILLED CRESCENT WITH NOTATION OF NATO CODE NUMBER FOR ROCKET OXIDIZER AND MAXIMUM FILLING PRESSURE IN ENGLISH AND METRIC SYSTEMS</p>	 NATO CODE NO. MAX FILLING PRESSURE ___ PSI ___ Kg/Cm ²	<p>6 AIR CONDITIONING</p> <p>DOT PATTERN</p>	
<p>7 ENGINE LUBRICATING OIL</p> <p>FILLED SQUARE WITH NOTATION OF NATO CODE NUMBER FOR ENGINE LUBRICATING OIL AND MAXIMUM FILLING PRESSURE IN ENGLISH AND METRIC SYSTEMS</p>	 NATO CODE NO. MAX FILLING PRESSURE ___ PSI ___ Kg/Cm ²	<p>8 INERTING SYSTEM</p> <p>FILLED SQUARE WITH A QUARTER ARC REMOVED FROM EACH CORNER, WITH TYPE OF GAS USED AND PRESSURE IN ENGLISH AND METRIC SYSTEMS</p>	 NITROGEN ___ PSI ___ Kg/Cm ²
<p>9 HYDRAULIC FLUID</p> <p>FILLED CIRCLE WITH NOTATION OF NATO CODE NUMBER FOR HYDRAULIC FLUID AND MAXIMUM FILLING PRESSURE IN ENGLISH AND METRIC SYSTEMS</p>	 NATO CODE NO. MAX FILLING PRESSURE ___ PSI ___ Kg/Cm ²	<p>10 FIRE EXTINGUISHING SYSTEM</p> <p>A FILLED DIAMOND WITH NOTATION SHOWING NATO CODE NUMBER</p>	 NATO CODE NO.
<p>11 DEICING</p> <p>FILLED TRIANGLE WITH NOTATION OF NATO CODE NUMBER FOR DEICING FLUID</p>	 NATO CODE NO.	<p>12 EXTERNAL ELECTRICAL CONNECTIONS</p> <p>A FILLED VERTICAL BAR WITH THREE EQUALLY SPACED HORIZONTAL BARS ON RIGHT HAND SIDE WITH NOTATIONS TO INDICATE CHARACTERISTICS AND PURPOSE</p>	 ..SERVICING ..STARTING ETC 28V OR 115V DC 115/200V, 400 CYCLES
<p>13 COOLANT</p> <p>TWO FILLED HORIZONTAL S's WITH NOTATION OF NATO CODE NUMBER FOR COOLANT AND PERCENTAGE COMPOSITION IF NECESSARY</p>	 NATO CODE NO. WATER ___ % COOLANT ___ %	<p>14 GROUNDING OR EARTHING RECEPTACLE</p> <p>A FILLED INVERTED "T" WITH TWO PARALLEL BARS UNDERNEATH WHICH DIMINISH IN SIZE</p>	 GROUND (EARTH) HERE

000895

Figure 8-3. NATO Marking Symbols (sheet 1 of 5)

FILLING (CONT) COLOR-BLACK OR WHITE ACCORDING TO BACKGROUND	
<p>15 PNEUMATIC SYSTEM FILLED WITH NOTATION OF MAXIMUM CHARGING PRESSURE IN ENGLISH AND METRIC SYSTEMS</p> <div style="text-align: center;">  </div> <p style="text-align: center;">MAX CHARGING PRESSURE ___ PSI ___ Kg/Cm2</p>	<p>16 PNUMATIC STARTER CONNECTION A FILLED X CIRCUMSCRIBED BY A FILLED RING NOTATION OF MAXIMUM OPERATING PRESSURE IN ENGLISH AND METRIC SYSTEM</p> <div style="text-align: center;">  </div> <p style="text-align: center;">MAX OPERATING PRESSURE ___ PSI ___ Kg/Cm2</p>
<p>17 FUEL TANK WATER GRAIN OFF</p> <div style="text-align: center;">  </div>	

<p>18A FLIGHT DATA RECORDER</p>	<p>BLACK SYMBOLS ON WHITE BACKGROUND OR WHITE SYMBOLS ON BLACK BACKGROUND</p>	
---	---	---


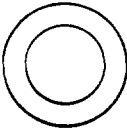

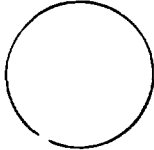


GROUND HANDLING COLOR-YELLOW OR ORANGE OUTLINE SYMBOLS IN BLACK OR WHITE ACCORDING TO BACKGROUND	
<p>18 JACKING POINT YELLOW FILLED SQUARE WITH TWO SLANTING LEGS ON BOTTOM SIDE</p> <div style="text-align: center;">  </div>	<p>19 TOWING ORANGE FILLED RING NOTE: OPTIONAL WHERE TOWING POINT IS OBVIOUS AND SUITABLE LOCATION FOR SYMBOL IS NOT AVAILABLE</p> <div style="text-align: center;">  </div>
<p>20 SLINGING OR HOISTING POINTS YELLOW FILLED HOOK ON A HORIZONTAL LINE</p> <div style="text-align: center;">  </div>	<p>21 TAIL SUPPORT ORGANGE CIRCLE AROUND THE POINT OF SUPPORT</p> <div style="text-align: center;">  </div>
<p>22 MOORING OR PICKETING YELLOW FILLED ANCHOR</p> <div style="text-align: center;">  </div>	<p>23 LOCKING OF DROP TANK ORANGE FILLED STAR</p> <div style="text-align: center;">  </div>

Figure 8-3. NATO Marking Symbols (Sheet 2 of 5)

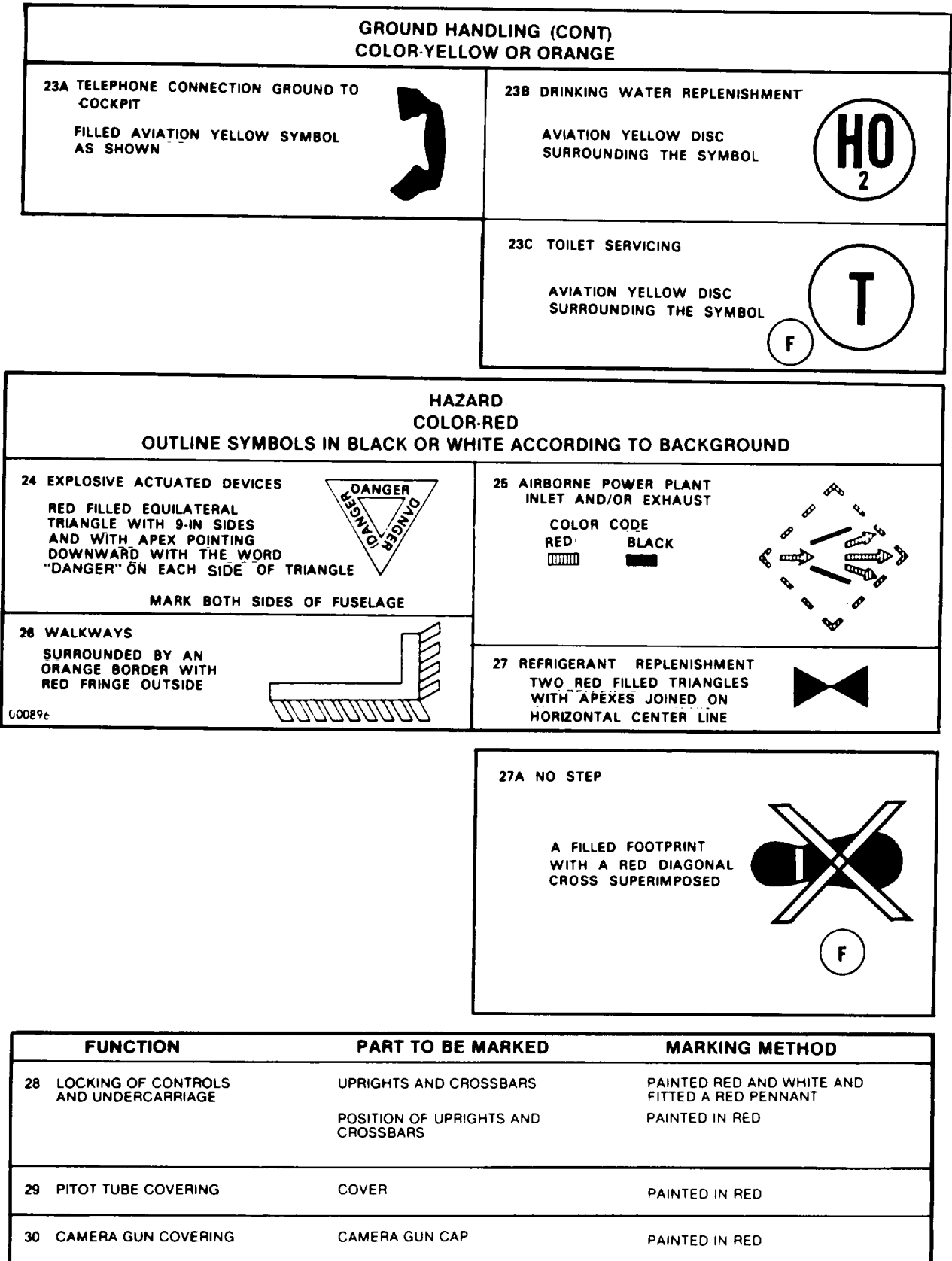


Figure 8-3. NATO Markings Symbols (Sheet 3 of 5)


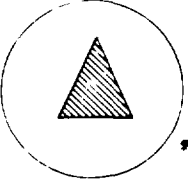
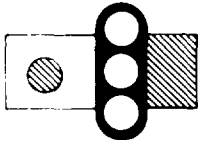
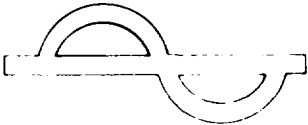
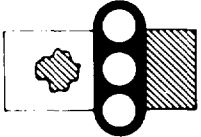
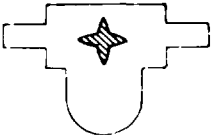
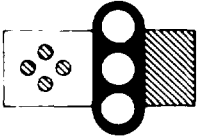
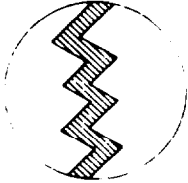
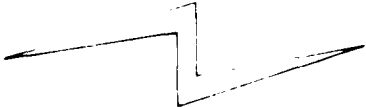

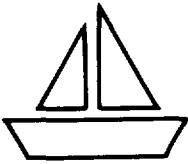
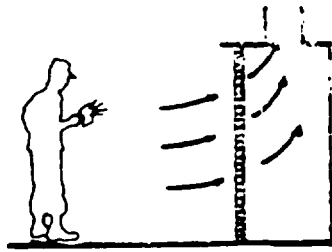
HAZARD (CONT) COLOR-RED		
FUNCTION	PART TO BE MARKED	MARKING METHOD
31 JET ENGINE COVERING	TAMPIONS	PAINTED IN RED
32 ROCKET CONTROL	ELECTRIC PLUG	 RED AND WHITE PENNANT
33 ANTIFIRING CONTROL	SHUNT	RED PENNANT WITH BLACK SKULL AND CROSS BONES
34 PROHIBITION OF ACCESS	WEAKER PARTS OF AIRCRAFT	BORDER BAND AND CROSS OF ST. ANDREWS IN RED
MAINTENANCE COLOR-ORANGE		
35 INSPECTION OF DEICING CIRCUIT		36 HYDRAULIC SYSTEM TEST 
37 INSPECTION OF ELECTRONIC INSTALLATION		38 NITROGEN TANK SYSTEM TEST 
39 INSPECTION OF FUEL FILTER		40 CABIN PRESSURE TEST 
41 INSPECTION OF STATIC CONNECTION		42 INSPECTION OF BATTERY 
		43 IGNITION PLUG FOR STARTING JET ENGINE 
		43A DINGHY STORAGE 

Figure 8-3. NATO Marking Symbols (Sheet 4 of 5)

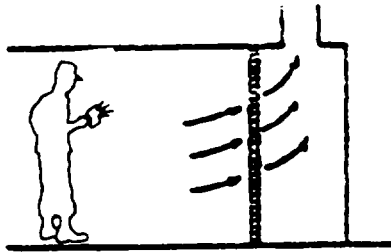
ARMAMENT AND AMMUNITION COLOR-GREEN								
FUNCTION	PART TO BE MARKED	SYMBOL						
44 GUN								
45 FIRING	SHUNT FOR CUTTING OUT FIRING SAFETY CONTROL							
	CARTRIDGE CONTAINER							
46 FEEDING OF GUNS	CARTRIDGE CASE							
	LINKS CONTAINER							
47 ROCKETS CONTROL	SELECTION PLUG							
48 BOMB RACKS	ATTACHMENT POINT FOR HOIST							
<p>NOTE: LETTERING WHICH SUPPLEMENTS THE SYMBOLS SHALL BE IN THE SCALE 1 TO 4 IN RELATION TO THE SYMBOL</p> <div style="display: flex; justify-content: space-around; align-items: center;"> <div style="text-align: center;"> </div> <div style="border: 1px solid black; padding: 5px; text-align: center;"> <p>DIMENSIONS ± 0.05 IN.</p> <table border="1" style="width: 100%; border-collapse: collapse;"> <thead> <tr> <th style="padding: 2px;">DIA</th> <th style="padding: 2px;">DIA/4</th> </tr> </thead> <tbody> <tr> <td style="padding: 2px;">2 INCHES</td> <td style="padding: 2px;">½ INCH</td> </tr> <tr> <td style="padding: 2px;">4 INCHES</td> <td style="padding: 2px;">1 INCH</td> </tr> </tbody> </table> </div> </div>			DIA	DIA/4	2 INCHES	½ INCH	4 INCHES	1 INCH
DIA	DIA/4							
2 INCHES	½ INCH							
4 INCHES	1 INCH							

Figure 8-3. NATO Marking Symbols (sheet 5 of 5)

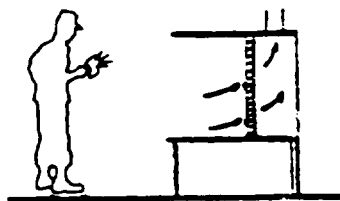
DRY TYPE



OPEN

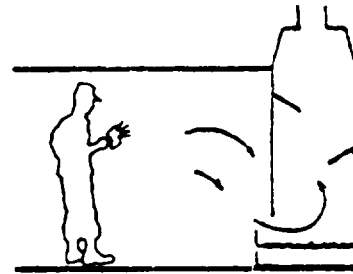


w/ENCLOSURE

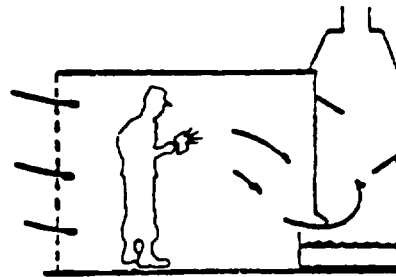


BENCH TYPE

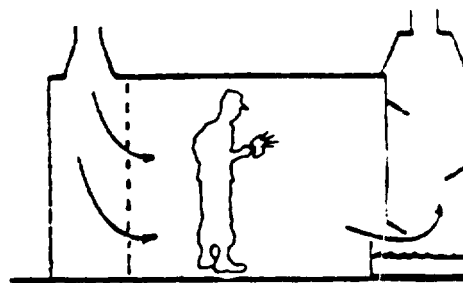
WATER WASH TYPE



w/ENCLOSURE



w/FILTER DOOR



w/INTEGRAL SUPPLY AIR

Figure 8-4. Sidedraft Paint Booths

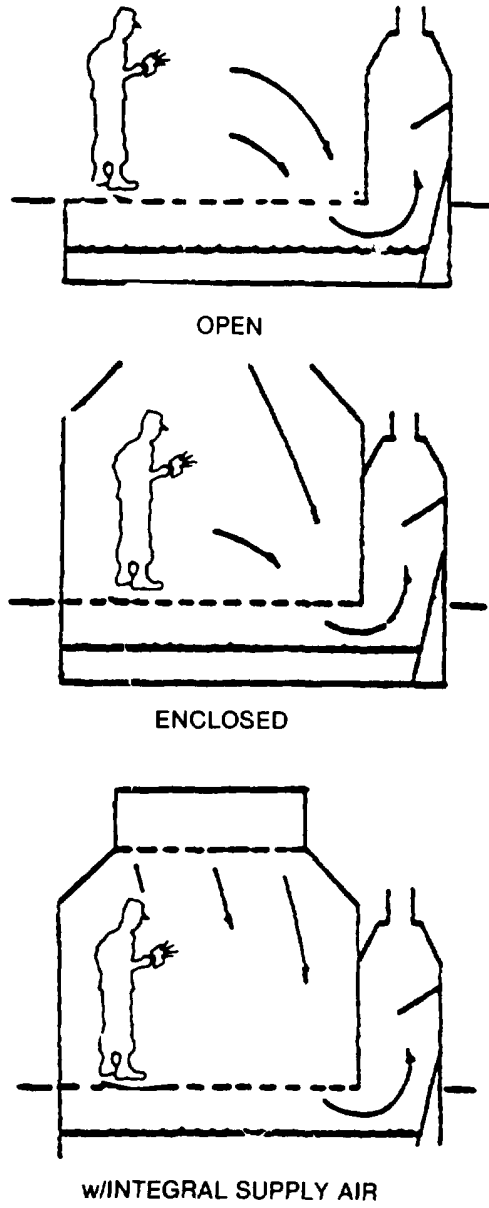
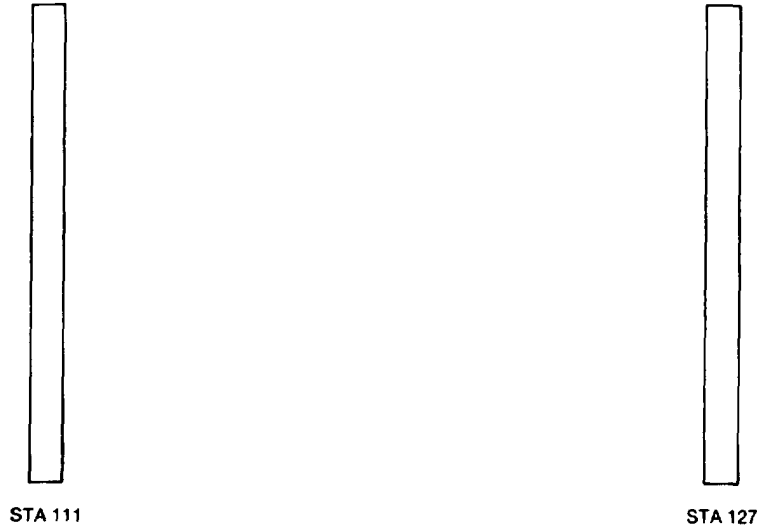


Figure 8-5. Downdraft Paint Booths



COMPARTMENT C

Figure 8-6. Typical Compartment Markings



Figure 8-7. First Aid Kit

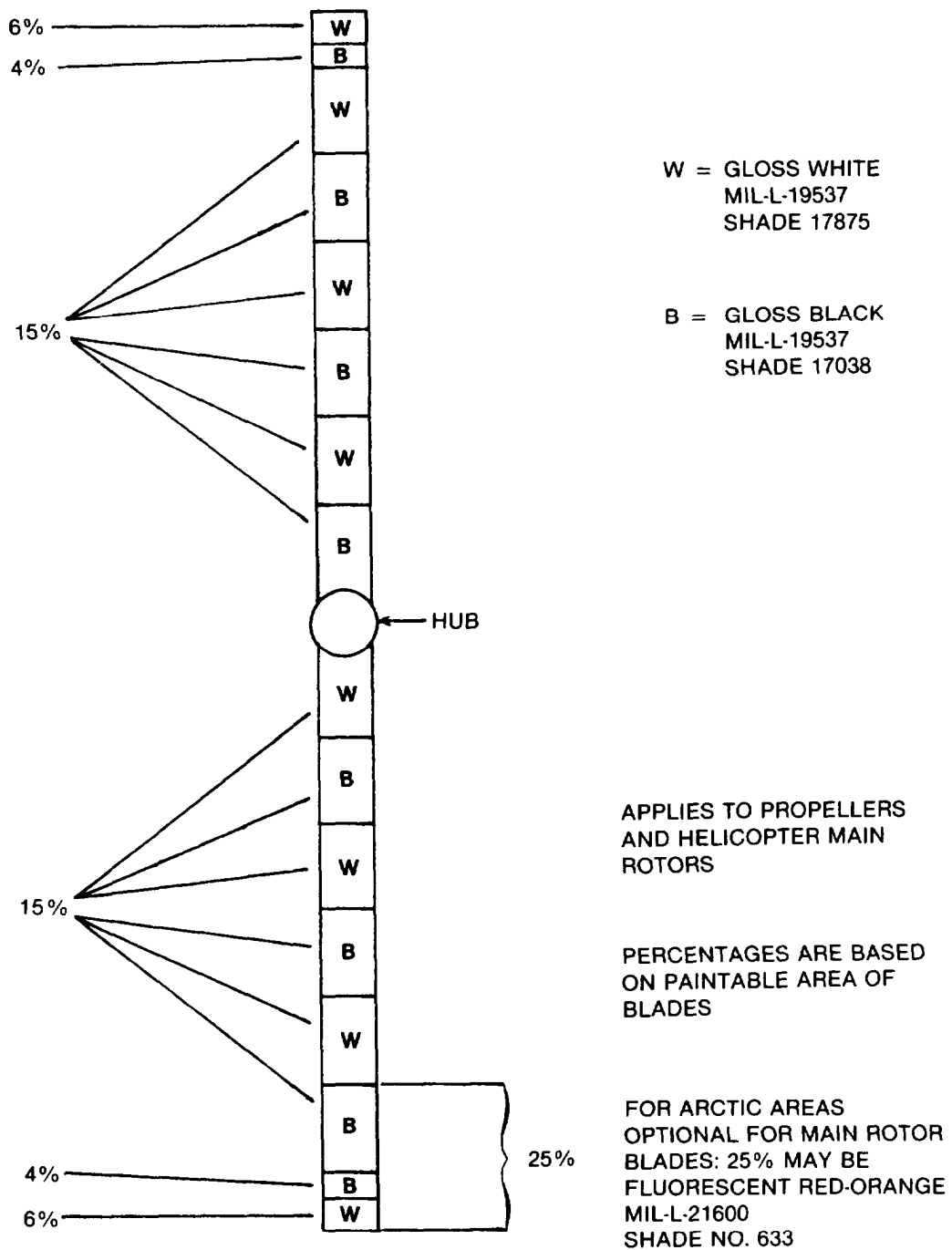


Figure 8-8. Optimum High Visibility Paint Scheme, Two Blade, Exposed Hub

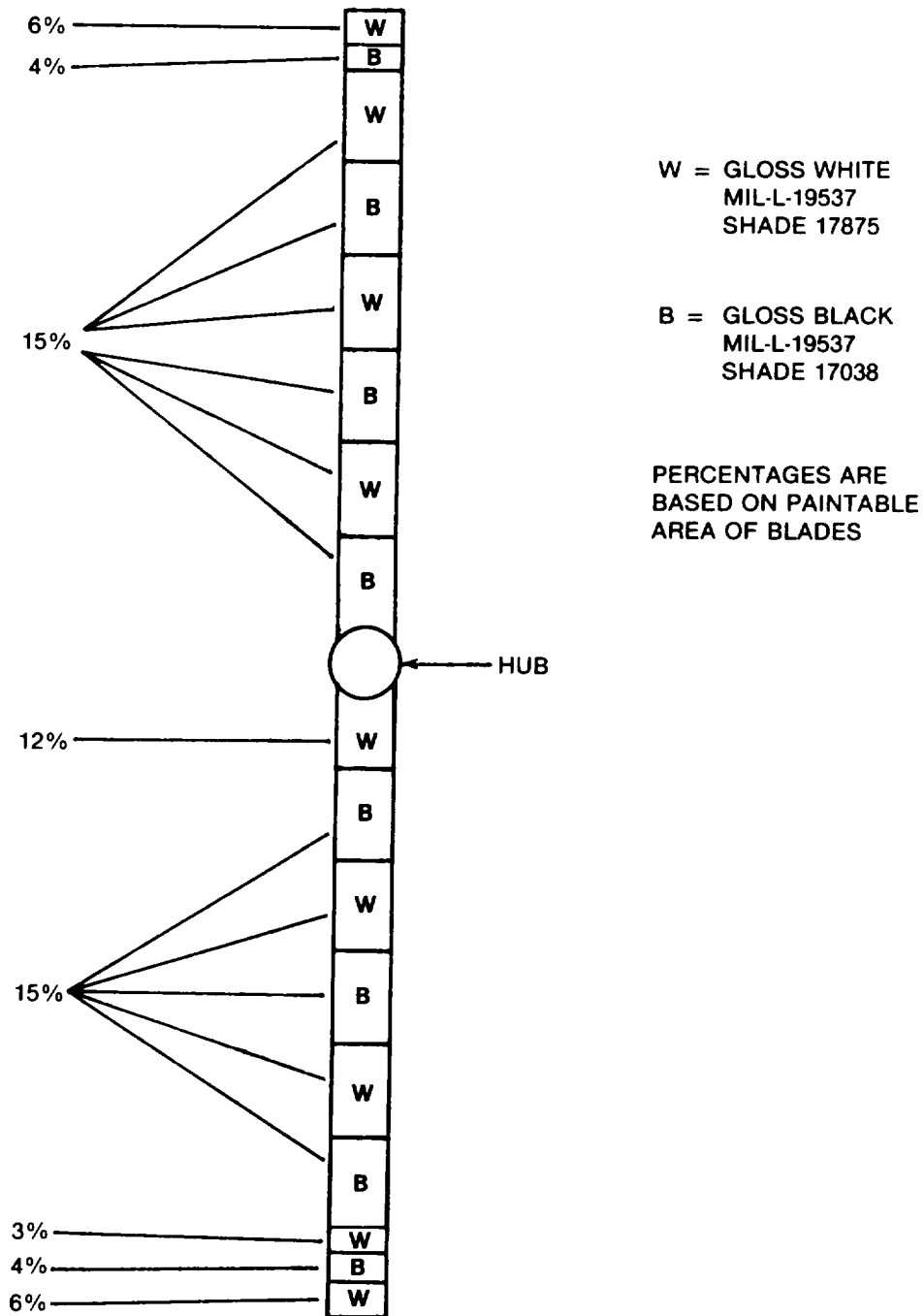


Figure 8-9. Optimum High Visibility Paint Scheme, Two Blades, Helicopter Tail Rotor Only

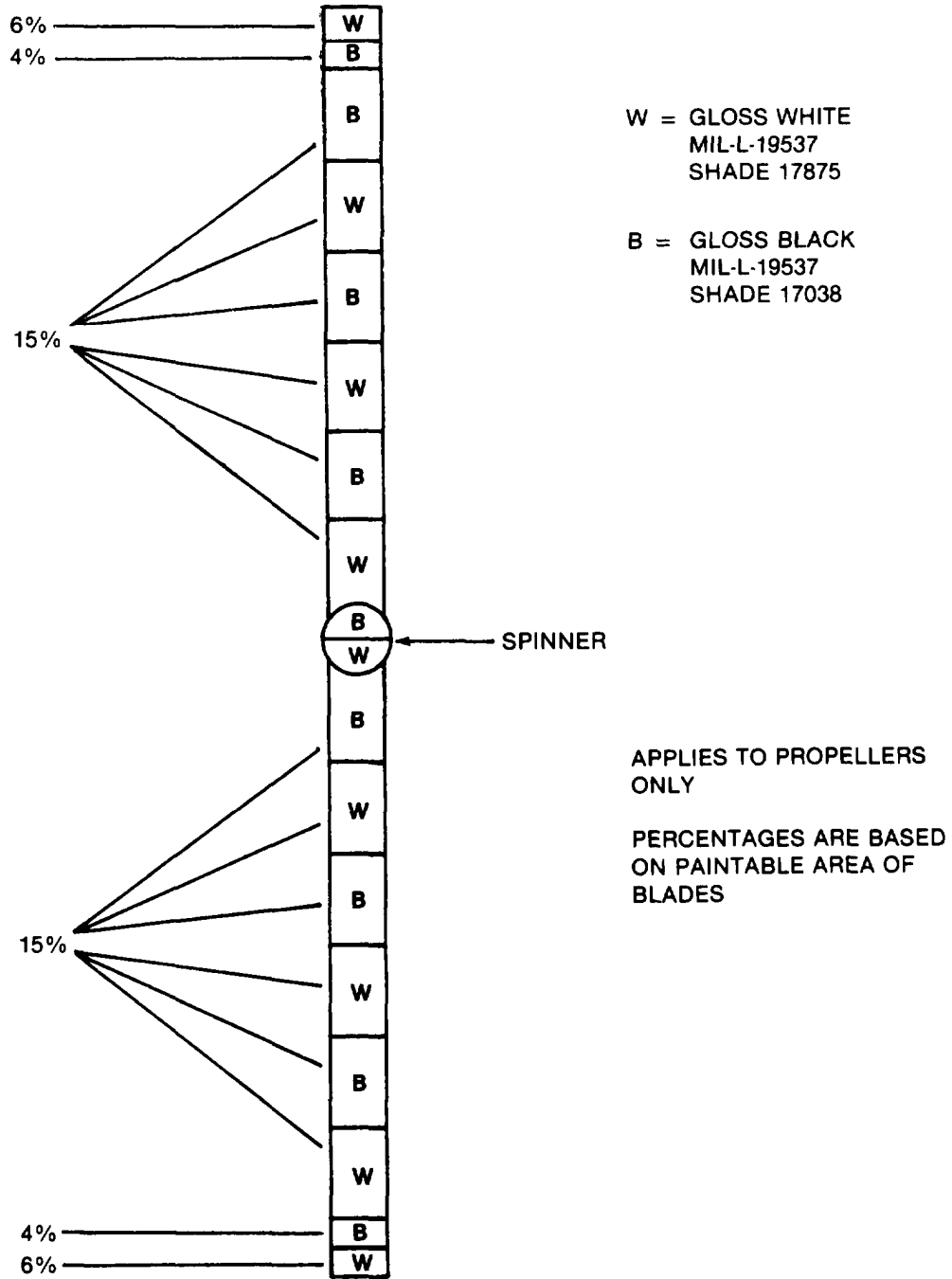


Figure 8-10. Optimum High Visibility Paint Scheme, Two Blades With Spinner

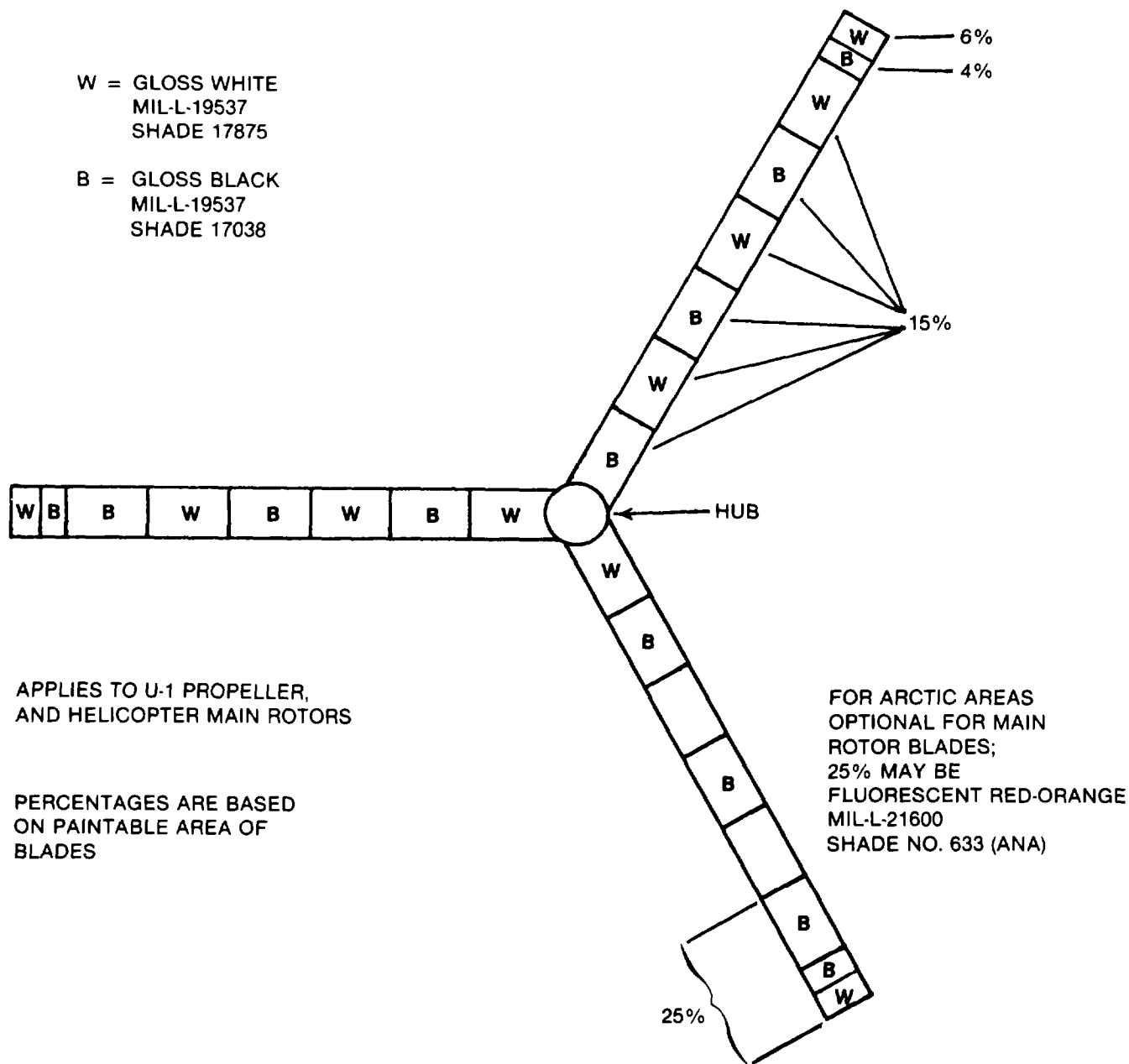


Figure 8-11. Optimum High Visibility Paint Scheme, Three Blades, Exposed Hub

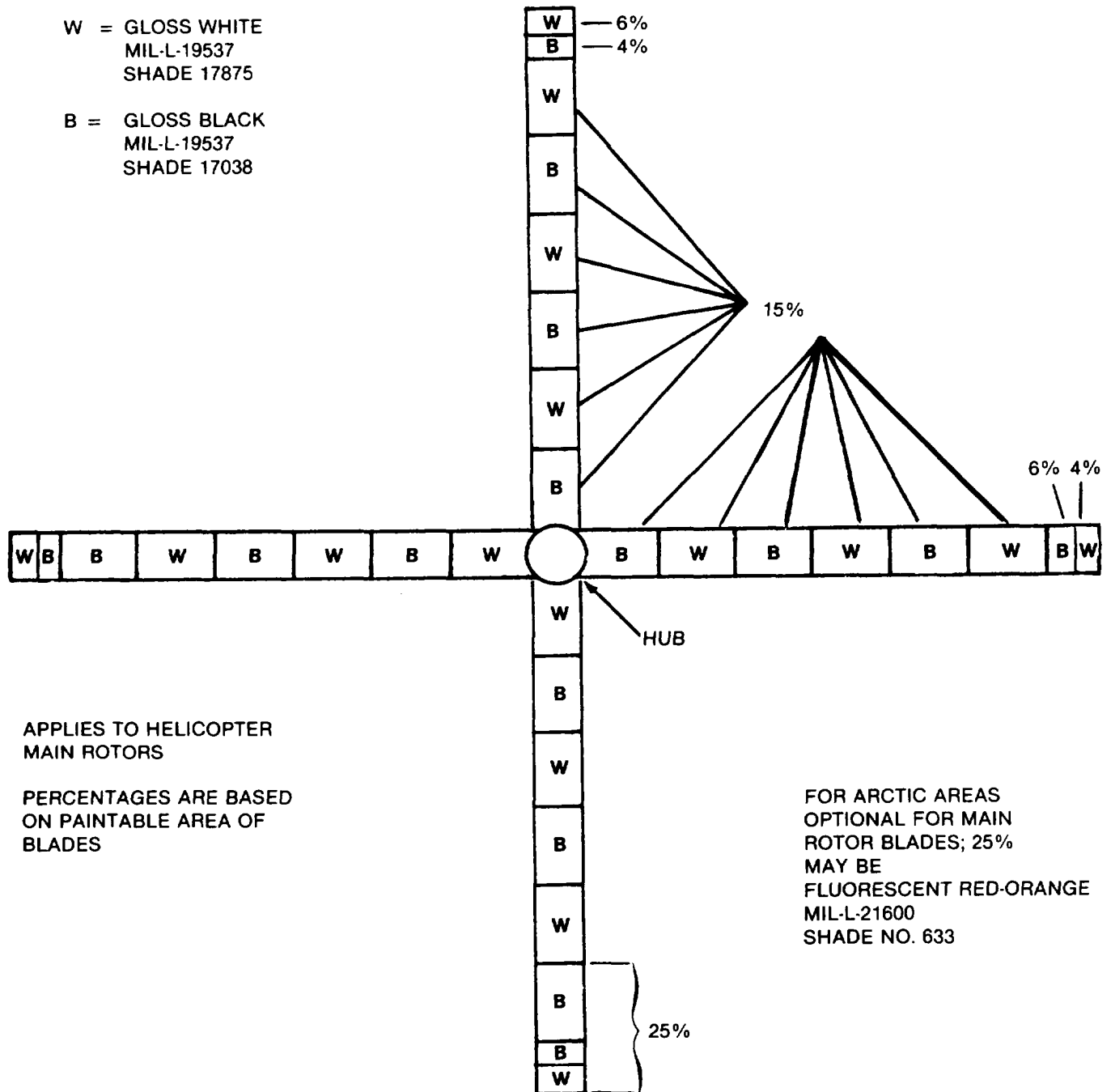


Figure 8-13. Optimum High Visibility Paint Scheme, Four Blades, Exposed Hub

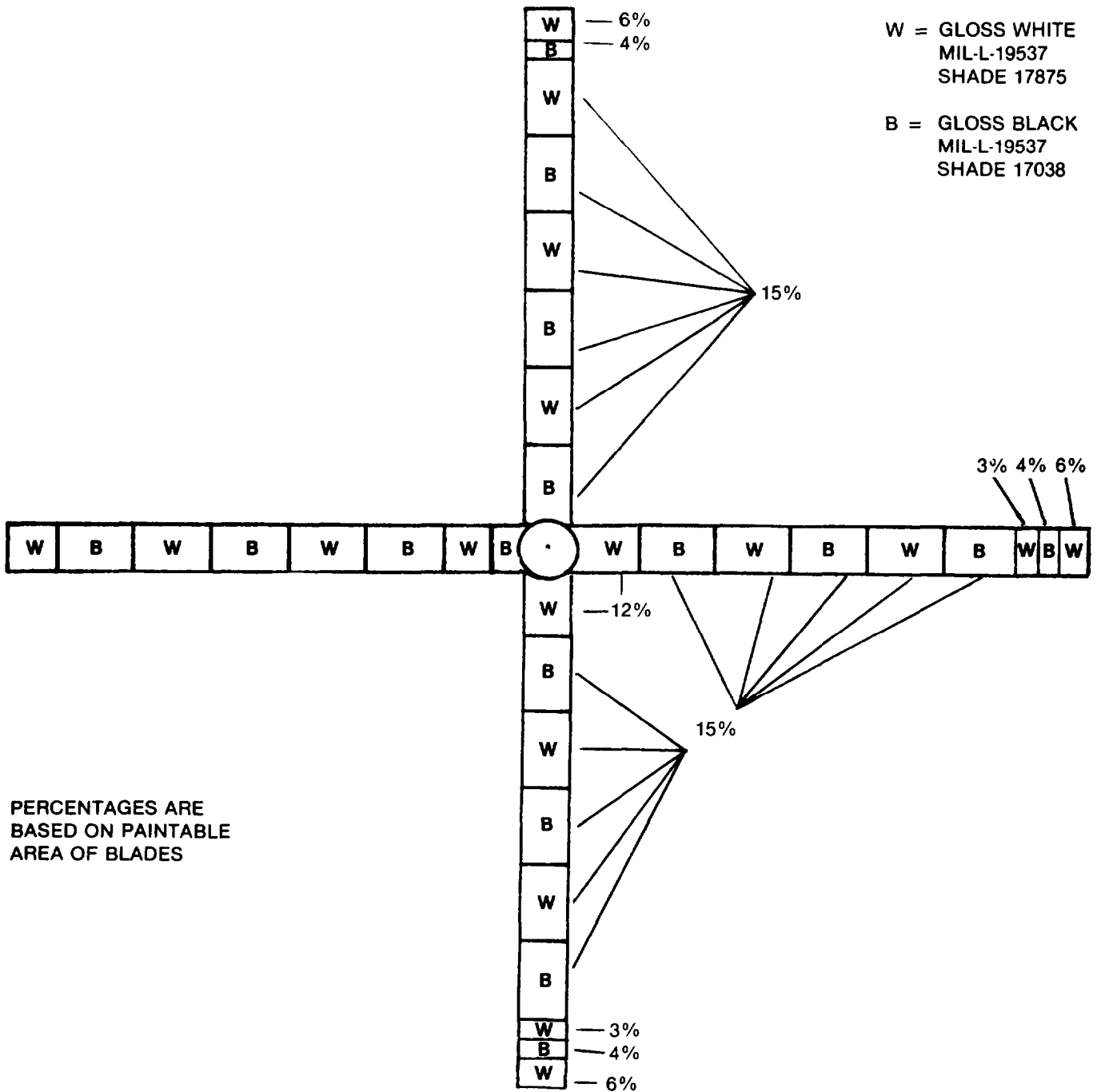
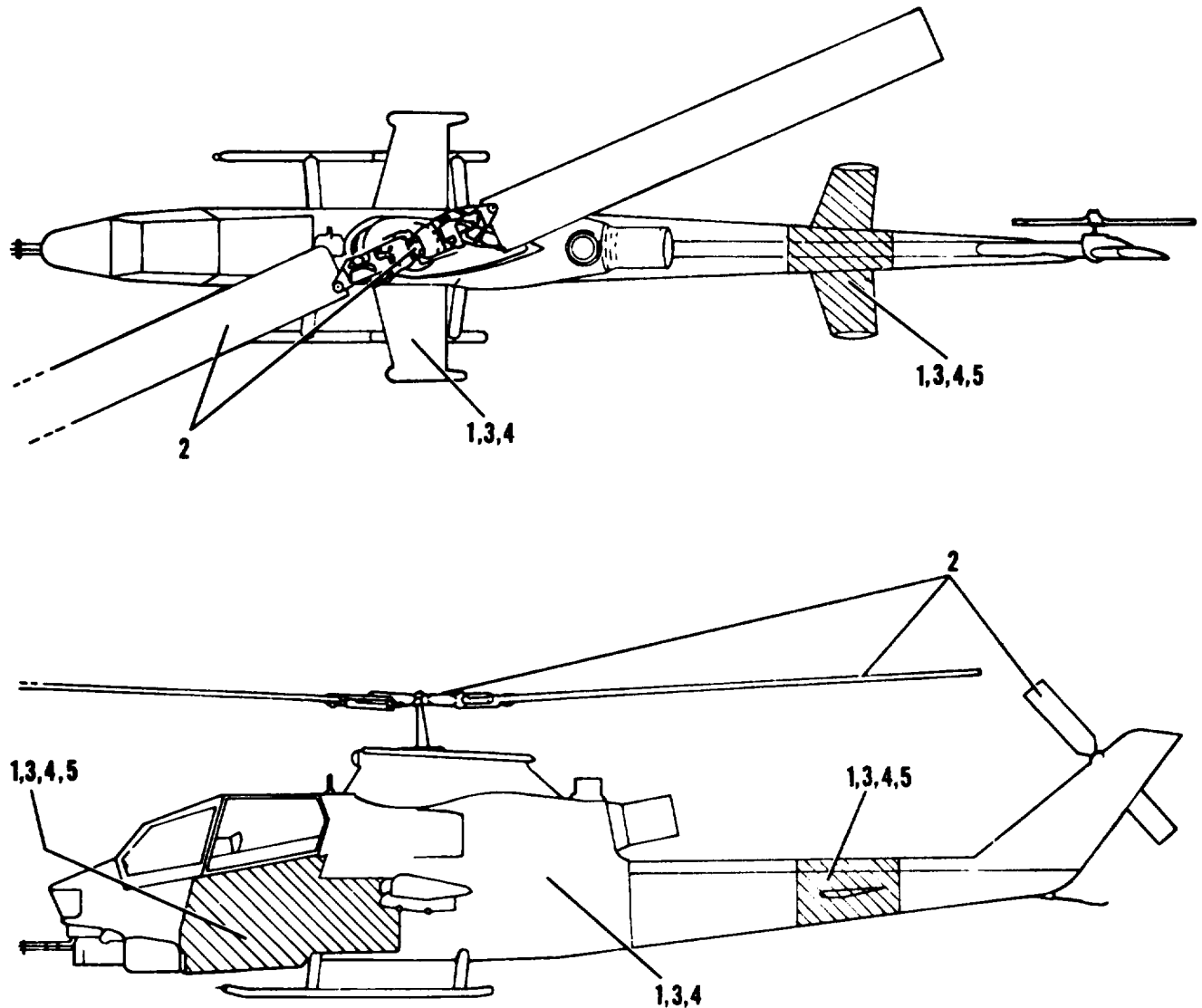


Figure 8-14. Optimum High Visibility Paint Scheme, Four Blades, Helicopter Tail Rotor Only

CHAPTER 9

HELICOPTER ILLUSTRATIONS

Section 1. AH-1 Illustrations



1. MI1-C-46168, aircraft green (entire aircraft, except as noted).
2. MI1-C-46168, aircraft black.
3. MI1-C-46168, dark sand (entire aircraft or high conspicuous color scheme when authorized, desert operations only). See Paragraph 5-11.
4. MI1-C-46168, aircraft white (entire aircraft or high conspicuous color scheme when authorized, arctic operations only). See Paragraph 5-11.
5. MI1-P-21600, fluorescent red-orange. ANA #633 (training aircraft-high visibility, only where authorized).

Figure 9-1. Tactical Paint Scheme, AH-1

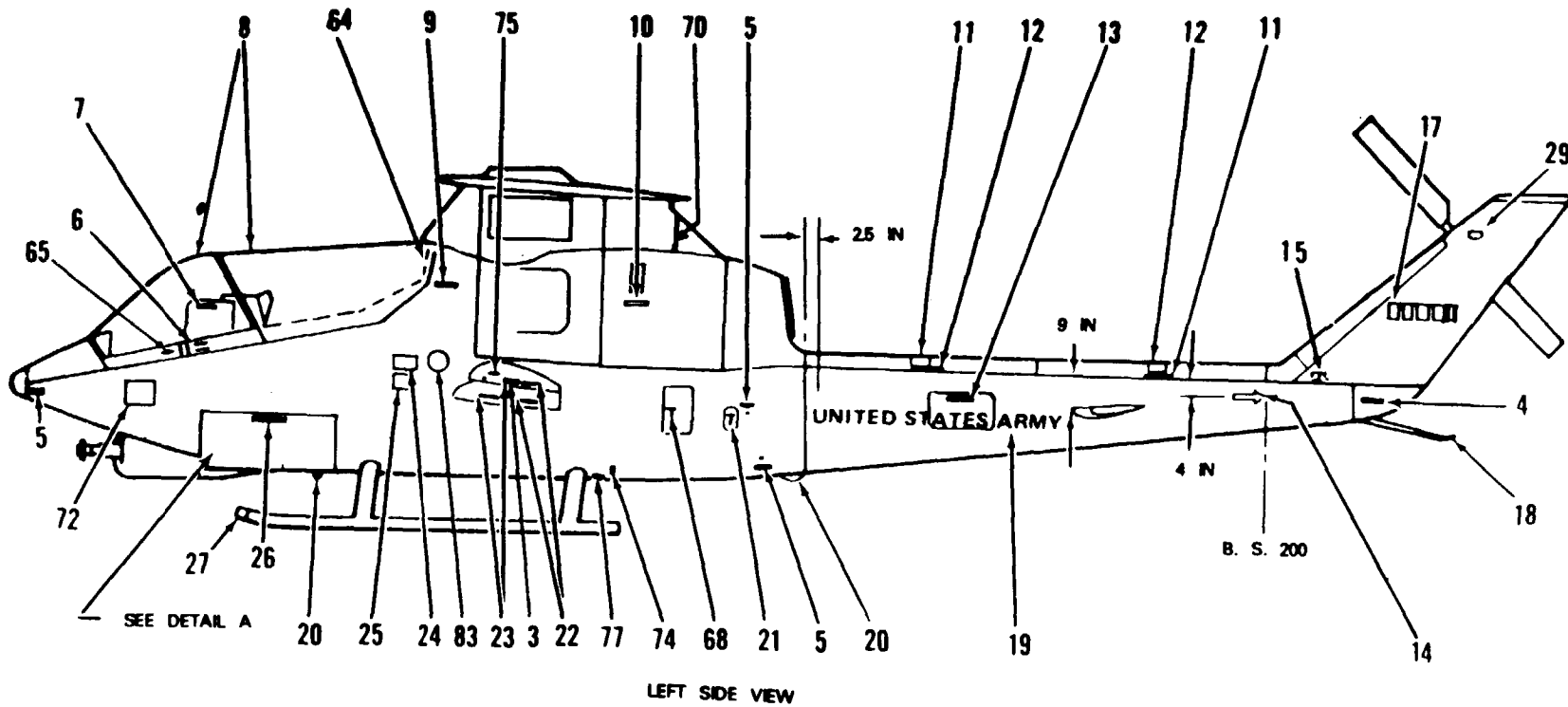


Figure 9-2. Exterior Marking, AH-1 (Sheet 1 of 10).

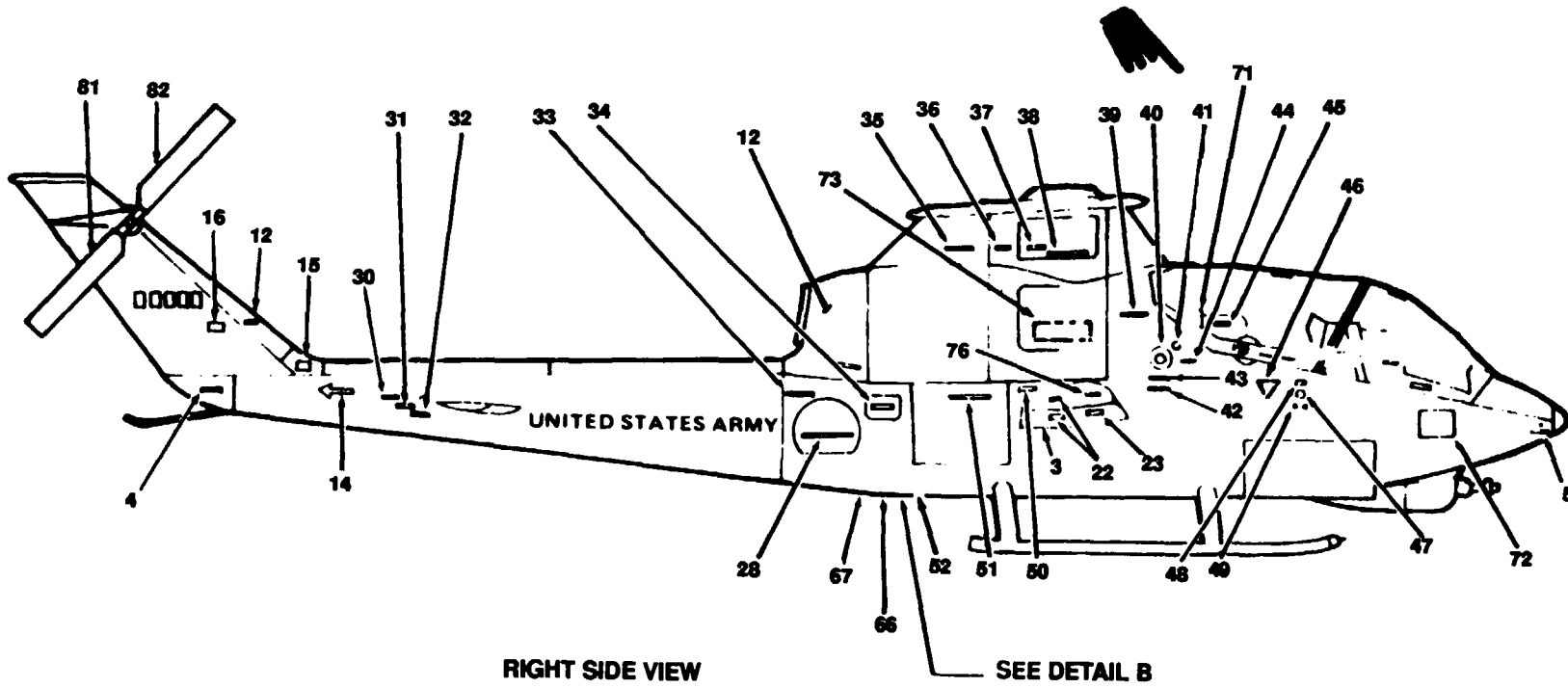
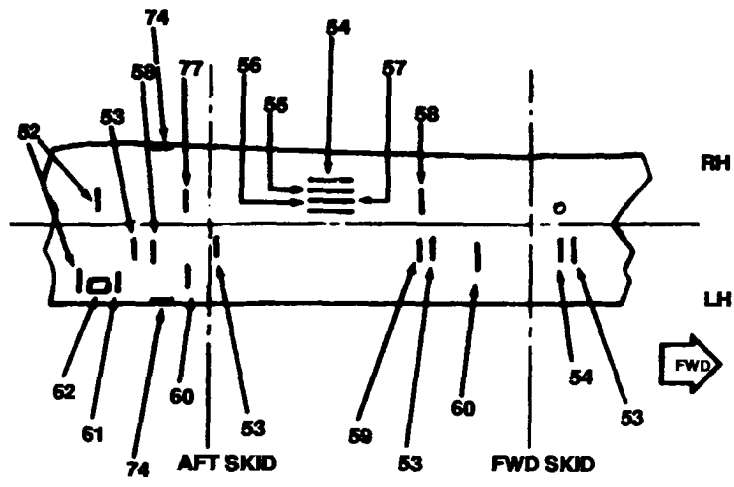
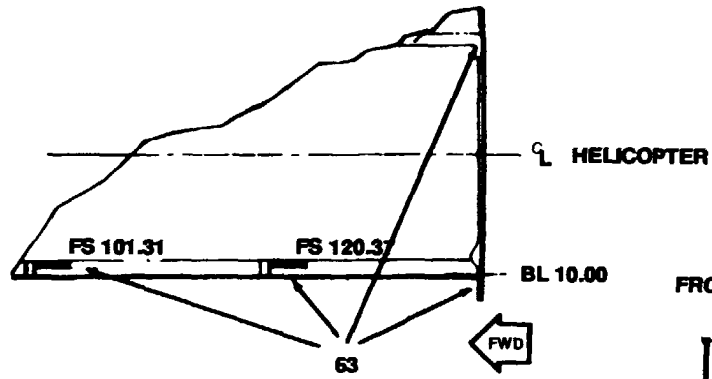


Figure 9-2. Exterior Markings, AH-1 (Sheet 2 of 10).



DETAIL B



DETAIL A

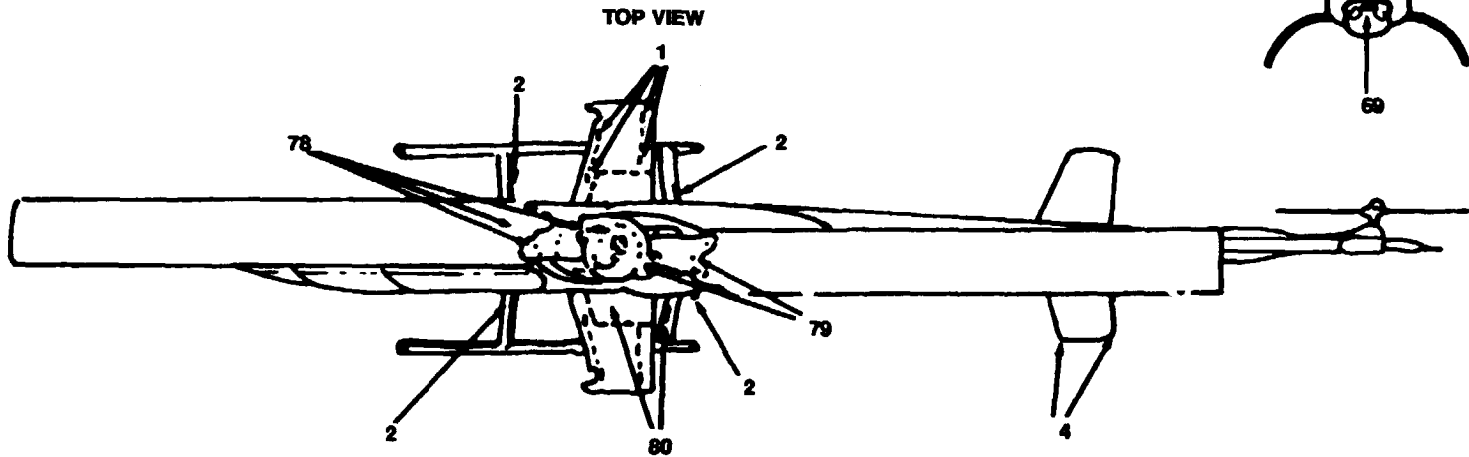
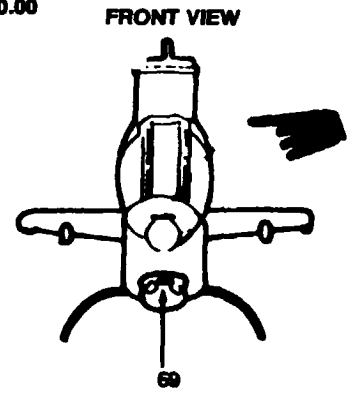


Figure 9-2. Exterior Markings, AH-1 (Sheet 3 of 10).


CODE NO.	DIRECTIONS	WORDING
1	Locate inner fwd stencils between edge of wing and synthetic walkway. Inner aft stencils 2 in. outboard from walkway and 6 in. fwd of trailing edge of wing. Outer stencils in line with inner stencils. Fwd stencils to read from fwd looking aft. Aft stencils to read from aft looking fwd. 1/2 in. MIL-C-416168, aircraft black No. 37038 letters.	NO STEP
2	Aft edge of cross tubes, 1/2-in. black letters.	NO STEP
3	Locate bottom side. 1/2-in. black letters.	CAUTION DISCONNECT ELECTRICAL WIRING BEFORE REMOVING WINGS
4	Top, 2-in. from edges and tip. 1/2-in black letters.	NO PUSH
5	1/2-in. black letters.	BATTERY VENT
6	Locate aft of handle, Pilot's and Gunner's canopy door. Arrows to be black 1-1/2 in. long with 1/4-in. shaft and 1/2-in. arrow head. 1-in, black letters.	
7	Locate top fwd gunners left hand armor plate, 1-in. MIL-C-46168, orange-yellow, No. 33638,	HAND FIRE EXTINGUISHER INSIDE
8	Paint broken band on inside pilots and gunners escape exit per para. 7-24. Paint orange-yellow.	
9	1/2-in. black letters, both sides.	HYD RESERVOIR INSIDE
10	1/2-in. MIL-CA16168, Aircraft Black No.37038 letters on both sides.	ACCESS FOR FIRE EXTINGUISHING
11	Locate inside of top cover ('B.L.O.') approx adjacent to shaft clamps. 1/2-in. aircraft black letters.	INSTALL SHAFT CLAMPS INDEXED 90° TO EACH OTHER TORQUE EVENLY ABOVE NUT FRICTION TORQUE TEE BOLT TYPE 20-25 IN. LB. THRU BOLT TYPE 30-35 IN. LB. TAP O.D. OF CLAMP LIGHTLY AND RETORQUE
12	1/2 in. black letters.	DRIVESHAFT ACCESS
13	1/2 in. black letters.	RADIO ACCESS

Figure 9-2. Exterior Markings, AH-1 (Sheet 4 of 10)


CODI NO.	DIRECTIONS	WORDING
14	Left and right side of tail boom 4-m. down from top of skin seam. 1-in. aircraft black letters, Arrow head will start at body station 200, Arrow points aft. paint arrow aircraft black, #37038.	
15	Aft of 42 degree gearbox cover on left hand side of tail fin, 1/2-in. black letters with 1/4-in. spacing between top and bottom of each line.	REMOVE TO SERVICE WITH MIL-L-23699 OIL ABOVE - 32°C AMBIENT TEMPERATURE MIL-L-7808 OIL BELOW - 32°C AMBIENT TEMPERATURE
16	Locate parallel to ground below tail rotor tie down loop. 1/4-in black letters.	TAIL ROTOR TIE DOWN
17	Both sides of fin, use 6-in. black letters with the bottom of the letters on the horizontal 17-in. above tailboom.	(Radio call numbers)
18	Paint tail skid aircraft green, MIL-C-46168.	
19	Both sides of aircraft. Most fwd letter (u-left side, Y-right side) to start 2 1/2-in. aft of tailboom joint. Top of letters are 9-in. down from and parallel to top skin seam. Letters to be 6-in. high lusterless black. Additional dimensions and spacing in accordance with Fig. 8-2.	UNITED STATES ARMY
20	Locate adjacent to and aft of tie down. Forward and aft tie-down fittings. Use 1/4-in. black letters.	TIEDOWN ALLOWABLE LOAD 2000 LBS
21	1/2-in. black letters 1/4-in. spacing between lines.	EXTERNAL POWER
22	Left and right outbd pylon fairigs. 1/2-m. black letters, 1/8-in. spacing between lines.	GROUND SAFETY PIN ACCESS
23	Left and right outbd and inbd pylon fairings. 5/8-in. black letters.	HOOK MANUAL RELEASE ACCESS
24	Use 1-in. black letters with 1/2-in. spacing between lines,	U.S. ARMY AH-1 (ADD APPLICABLE MODEL) U.S. ARMY SERIAL

Figure 9-2. Exterior Markings, AH-1 (Sheet 5 of 10)




CODE NO.	DIRECTIONS	WORDING
25	Use 1/2-in. black letters with 1/2-in. spacing between lines.	CAP 262 U.S. GAL FILL TO FORM F LIMITS USE MIL-T-83133 GRADE JP-8
26	1/2-in. black letters, both sides of fuselage.	AMMUNITION COMPARTMENT ACCESS
27	1/2-in. black letters. Apply to both skids.	TOW
28	1/2-in. black letters.	BATTERY ACCESS
29	1/2-in. black letters.	SERVICE GEAR BOX WITH MIL-L-23699 OIL ABOVE -32°C AMBIENT TEMP MIL-L-7808 OIL BELOW -32°C AMBIENT TEMP
30	Right side of tailboom, AFT of elevator. 1/4 inch letters "Rivet P". Arrow, 1/8 inch shaft, length of word "Rivet P". Paint rivet head same color as adjacent surface. The arrow will point to the specific rivet for travel.	
31	Right side of tailboom, AFT of elevator. 1/4 inch letters "Rivets". Arrow 1/2 inch long, 1/8 inch shaft, pointing down. Paint rivet head same color as adjacent surface. The arrow will point to the specific rivet for travel.	FULL AFT CYCLIC STICK RIVET S 
32	Right side of tailboom, AFT of elevator. 1/4 inch letters "Rivet R". Arrow length of word "Rivet R". Paint rivet head same color as adjacent surface. The arrow will point to the specific rivet for travel.	FULL AFT CYCLIC STICK RIVET R 
33	Both sides of fuselage 1/2-in. black letters.	CAUTION DISCONNECT ELECTRICAL WIRING BEFORE REMOVING TAIL BOOM
34	Locate on both sides of oil cooler door 1/2-in. blacking letters with 1/4-in. spacing between lines.	STRUCTURAL PANEL REQUIRED GROUND RUN AND FLIGHT
35	Locate on oil tank next to sight glass. 1/4 inch, aircraft olive drab letters.	MINIMUM OIL LEVEL
36	1/2-in. black letters.	ENGINE OIL MIL-L-23699 OIL ABOVE -32° C AMBIENT TEMP MIL-L-7808 OIL BELOW -32° C AMBIENT TEMP
37	1/2-in. black letters,	ENGINE OIL FILLER CAP ACCESS
38	Locate both sides of fuselage bottom of pylon fairing door. 1/2-in. black letters.	PYLON ACCESS DOOR

Figure 9-2. Exterior Markings, AH-1 (Sheet 6 of 10)



CODE NO.	DIRECTIONS	WORDING
39	Locate on RH hydraulic compartment door. one on outside surface and one upside down on inside surface. 1/4-in. black letters.	HYD RES DOOR MUST BE CLOSED WHEN OPENING OR CLOSING CANOPY
40	Delete	
41	Paint a black ground symbol, shade 37038, dimensions per MIL-C-83413/9-2	
42	Locate under fuel filter cap. 1/2-in. black letters.	CAP. 262 U.S. GAL FILL TO FORM F LIMITS USE MIL-T-83133 GRADE JP-8
43	Locate below fuel cap. Markings to be black standard NATO symbol for grounding receptacle	
44	Locate below ground jack plug. Markings to be black standard NATO symbol for grounding receptacle	
45	Locate on Pilot's armor panel. 1/2-in orange-yellow letters.	HAND HOLD
46	On fuselage above pilot's and co-pilot's step. Each side of triangle is to be 8-1/4 in. and 3/4 in. letters. Center stencil below triangle. One in. letters on top line, 1/2 in. letters on remainder. Letters to be aircraft black. Insert the complete TM number for the correct model helicopter in place of the Xs: 221-23 for AH-1G and TH-1G; 234-23 for AH-1S (MOD); 239-23 for AH-1S (MC); and 236-23 for AH-1S (PROD) (ECAS) (MC).	<p style="text-align: center;">CARTRIDGE ACTUATED DEVICE WARNING</p> <p>THIS AIRCRAFT CONTAINS A CARTRIDGE ACTUATED EMERGENCY ESCAPE SYSTEM EQUIPPED WITH EXPLOSIVE CHARGE. SEE TM 551520-XXX-XX FOR COMPLETE INSTRUCTIONS.</p>
47	Both sides of fuselage. Paint a black 3/8-in. wide broken band with a 2-3/4 in. outside diameter static part*	

Figure 9-2. Exterior Markings, AH-1 (Sheet 7 of 10)

CODE NO.	DIRECTIONS	WORDING
48	Both sides of fuselage above circle at static port 1/4-in black letters	DO NOT PLUG OR DEFORM HOLES
49	Both sides of fuselage below circle at static port 1/4-in. black letters	STATIC PORT
50	Above transmission oil level, light, 1/2-in. black letters	XMSN OIL LEVEL LIGHT
51	Locate top of oil cooler duct panel 1/4 m. black letters. Insert the complete TM number fix the correct model helicopter in place of the Xs: 221-23 for AH-1G and TH-1G 234-23 for AH-1S (MOD); 239-23 for AH-1S (MC); and 236-23 for AH-IS (PROD) (ECAS) (MC)	BEFORE REMOVING THIS PANEL THE FUSELAGE AFT JACK POINT MUST BE SUPPORTED - REFER TO TM 55-1520-XXX-XX MAINT. MANUAL.
52	Bottom of fuselage. 1/2-in. black letters	OIL COOLER COMPARTMENT DRAIN
53	Bottom of fuselage. 1/2-in. black letters	FUEL CELL CAVITY DRAIN & VENT
54	Bottom of fuselage. 1/2-in. black letters	FUEL CELL VENT.
55	Bottom of fuselage. 1/2-in. black letters	HYD RESERVOIR SCUPPER DRAIN
56	Bottom of fuselage. 1/2-in. black letters	HYD PUMP DRAIN
57	Bottom of fuselage. 1/2-in. black letters	XMSN OIL DRAIN
58	Bottom of fuselage. 1/2-in. black letters	FUEL CELL DRAIN
59	Bosom of fuselage. 1/2-in. black letters	HYD DECK DRAIN
60	Bottom of fuselage. 1/2-in. black letters	FUEL PUMP DRAIN
61	Bottom of fuselage. 1/2-in. black letters. Arrow 1.2 in. long with 1/4-in. shaft and 1/2-in. arrowhead	STARTER GEN → PAD DRAIN ↑ 1/2 in.
62	Bottom of fuselage. 1/2-in. black letters Arrow 3.30 in. long with 1/4-in. shaft and 1/2-in. arrowhead	DRAIN FUEL FILTER ENGINE DECK ENG TAIL PIPE ENG FUEL CONTROL ENG COMB CHAMBER → ← 1/4

Figure 9-2. Exterior Markings, AH-1 (Sheet 8 of 10)


CODE NO.	DIRECTIONS	WORDING
63	heated top of ammo floor. Use 1/4-in. black letters.	LEVEL HERE
64	Locate on soundproofing behind Pilot's seat centered between kit mounting studs. I&n. letters and 200 in. white square. 1/2in. xl 1/2-in. red cross, five 1/2-in. squares arranged in a symmetrical cross centered on 2-in. white background and below letters.	FIRST AID KIT
65	Left inside of gunner's armament control panel White letters on RED background. First line 1/4-in. letters. Last three lines 3/16-in letters. NOTE: Applicable on AH-1P and AH-1S.	WARNING DO NOT OPERATE TURRET WITH EITHER HYD SYSTEM PRESS LOW
66	On inside surface of panel assy adjacent to fwd grenade dispenser. 1/2-in. Orange-yellow letters.	NUMBER 1
67	On inside surface of panel assy adjacent to aft grenade dispenser. 1/2-in. orange-yellow letters.	NUMBER 2
68	To be located midway up and on the forward edge of the doorframe. 1/2-in. black letters. Arrow 1-m. long with 1/8-in. shaft and 14-in. arrowhead, color black.	 FWD
69	Locate above and centered between minigun(s) and/or grenade launcher(s), orange-yellow letters. First line 1-in. letters, last two lines 1/2-in. letters. NOTE Applicable on AH-1P and AH-1S.	WARNING GUN WILL FIRE IF ROTATED BY HAND
70	Paint a 2 in. wide lusterless black stripe over top of cowling to show turbine wheel location 10-1/2 in. forward from rear cowling.	
71	Located right side aft of pilot's seat 1/2-in. orange-yellow letters.	NO HAND HOLD
72	Authorized placement of unit insignia is on the nose access panel using aircraft black	
73	Locate inside on transmission pylon support ease. Use 1/2-in. black letters.	Survives Transmission with ML-L-23699 Oil Above -32°C Ambient Temp MIL-L-7808 Oil Below -32°C Ambient Temp
74	Both sides fuselage aircraft black	DRAIN FUEL SUMP DAILY

Figure 9-2. Exterior Marking, AH-1 (Sheet 9 of 10)





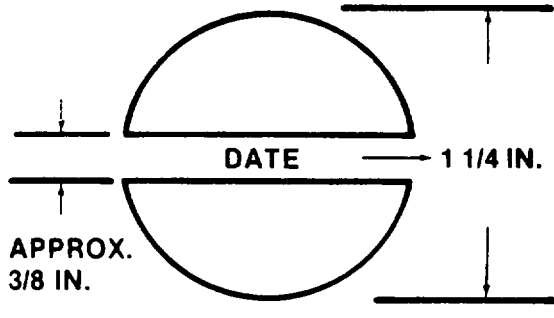
CODE NO.	DIRECTIONS	WORDING
75	Left outbd and inbd pylon fairing. 2/3 in. black letters.	HOOK MANUAL RELEASE ACCESS
76	Right outbd and inbd pylon fairing. 2/3 in. black letters.	HOOK MANUAL RELEASE ACCESS
77	Located on door on centerline of fuselage, aircraft black.	FUEL SUMP DRAIN ACCESS
78	A 1/2-in. diameter aircraft red dot on pitch horn and on upper and lower surface of blade and grip and attaching linkage	
79	A 1/2-in. diameter aircraft white dot on pitch horn and on upper and lower surface of blade and grip and attaching linkage	
80	Apply synthetic walkway MIL-W-5044 Type II on upper fwd edge of rear strut tubes, 2 in. x 12 in. and upper surface of wing roots, 18 in. wide, from 1 in. fwd of skin butt joint at fwd spar extending to trailing edge of wing	
81	A 1/2- in. diameter aircraft white dot on the tail rotor grip, attaching linkage and crosshead	
82	A 1/2-in. diameter aircraft red dot on the tail rotor grip, attaching linkage and crosshead.	
83	Aft of code 24. Note: Date shown is date aircraft painted with MIL-C46168 paint. Aircraft black.	

Figure 9-2. Exterior Markings, AH-1 (Sheet 10 of 10)

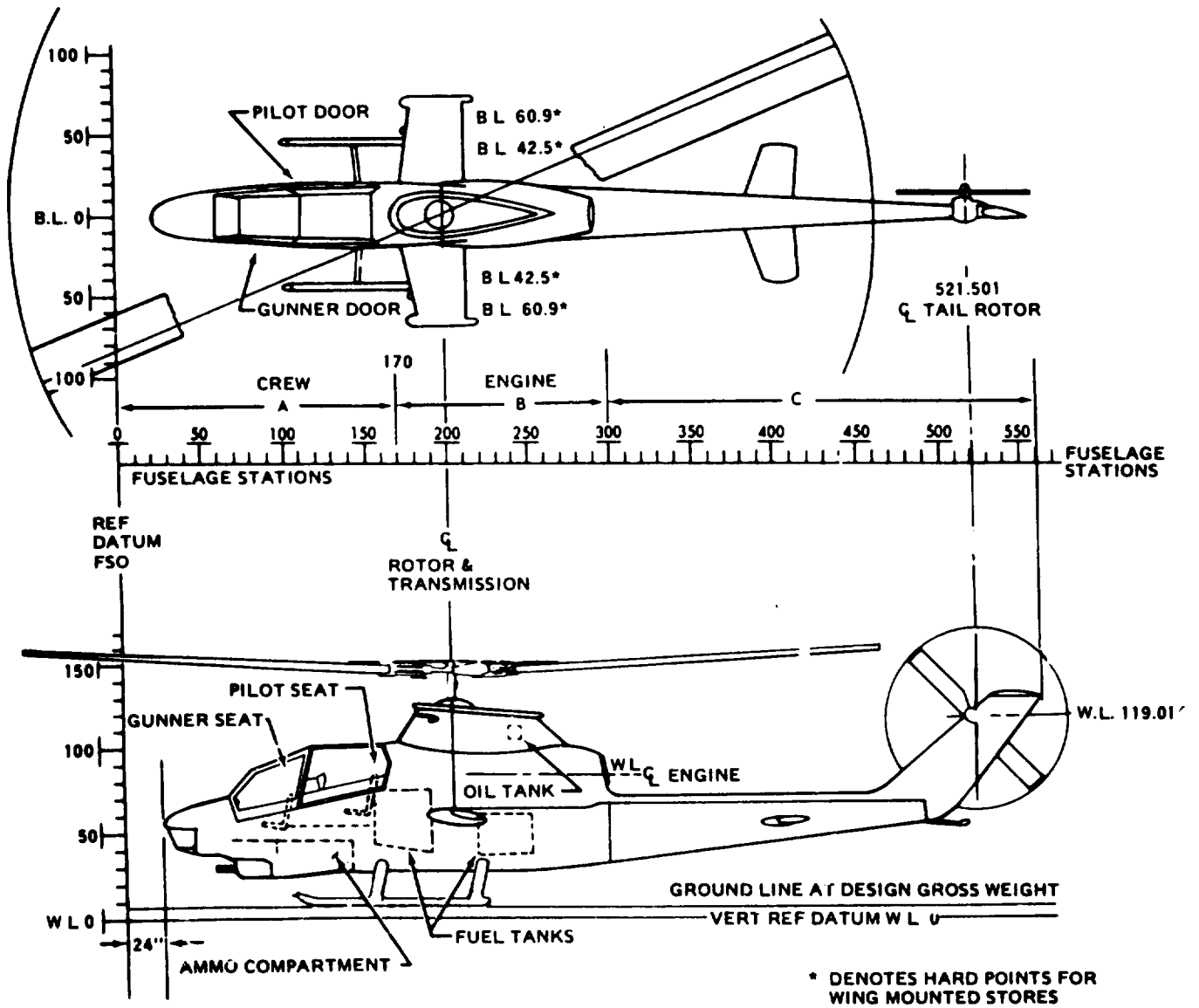
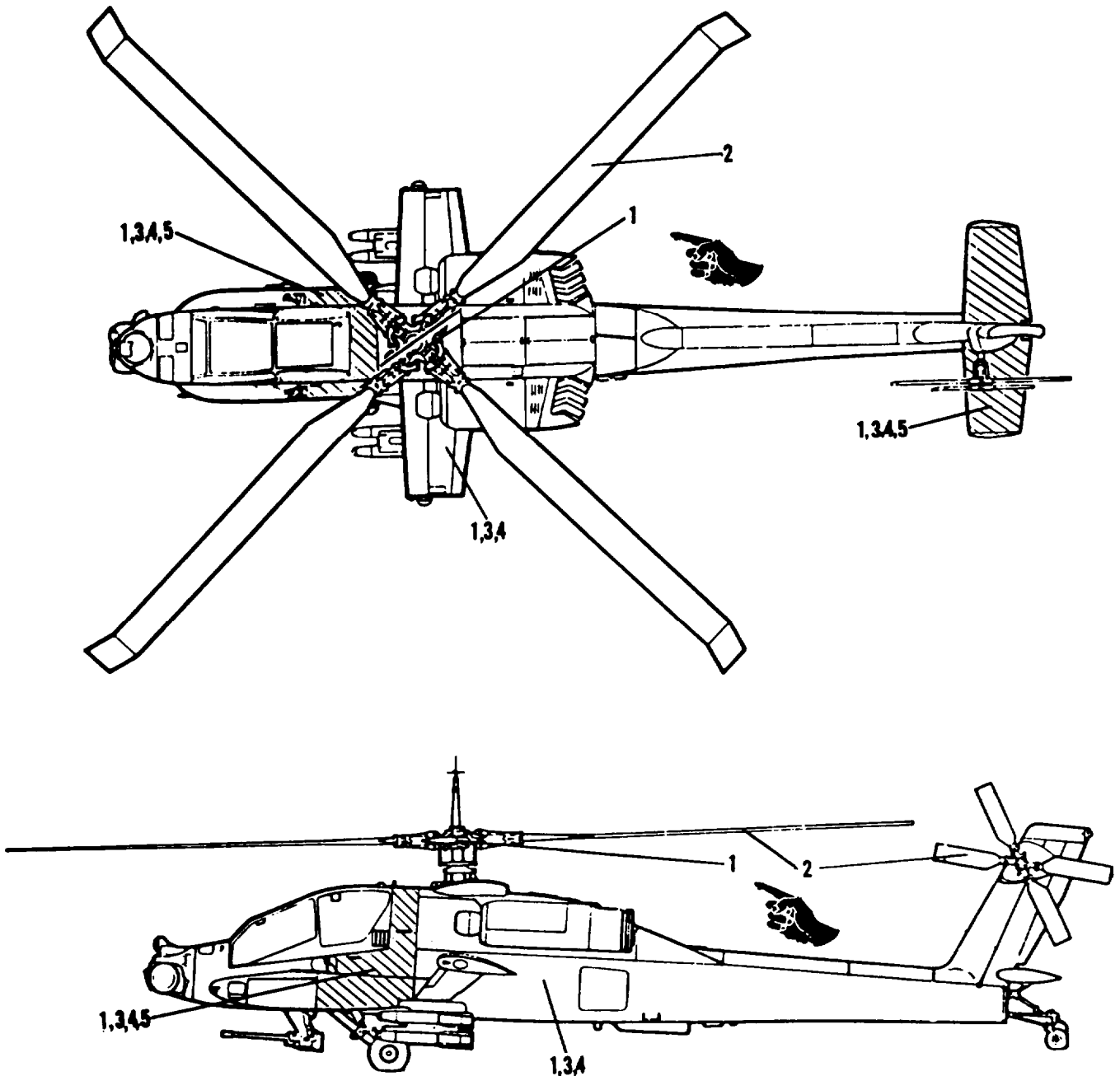


Figure 9-3. Station Diagram, AH-1

Section II. AH-64 Illustrations



1. MI1-C-46168, Aircraft Green (entire aircraft, except as noted).
2. MI1-C-46168, Aircraft Black.
3. MI1-C-46168, Dark Sand (entire aircraft or high conspicuous paint scheme when authorized, desert operations only). See Paragraph 5-11.
4. MI1-C-46168, Aircraft White (entire aircraft or high conspicuous paint scheme when authorized, arctic operations only). See Paragraph 5-11.
5. MIL-P-21600, Fluorescent Red-Orange. ANA #633 (training aircraft-high visibility, only where authorized).

Figure 9-4. Tactical Paint Scheme. AH-64.

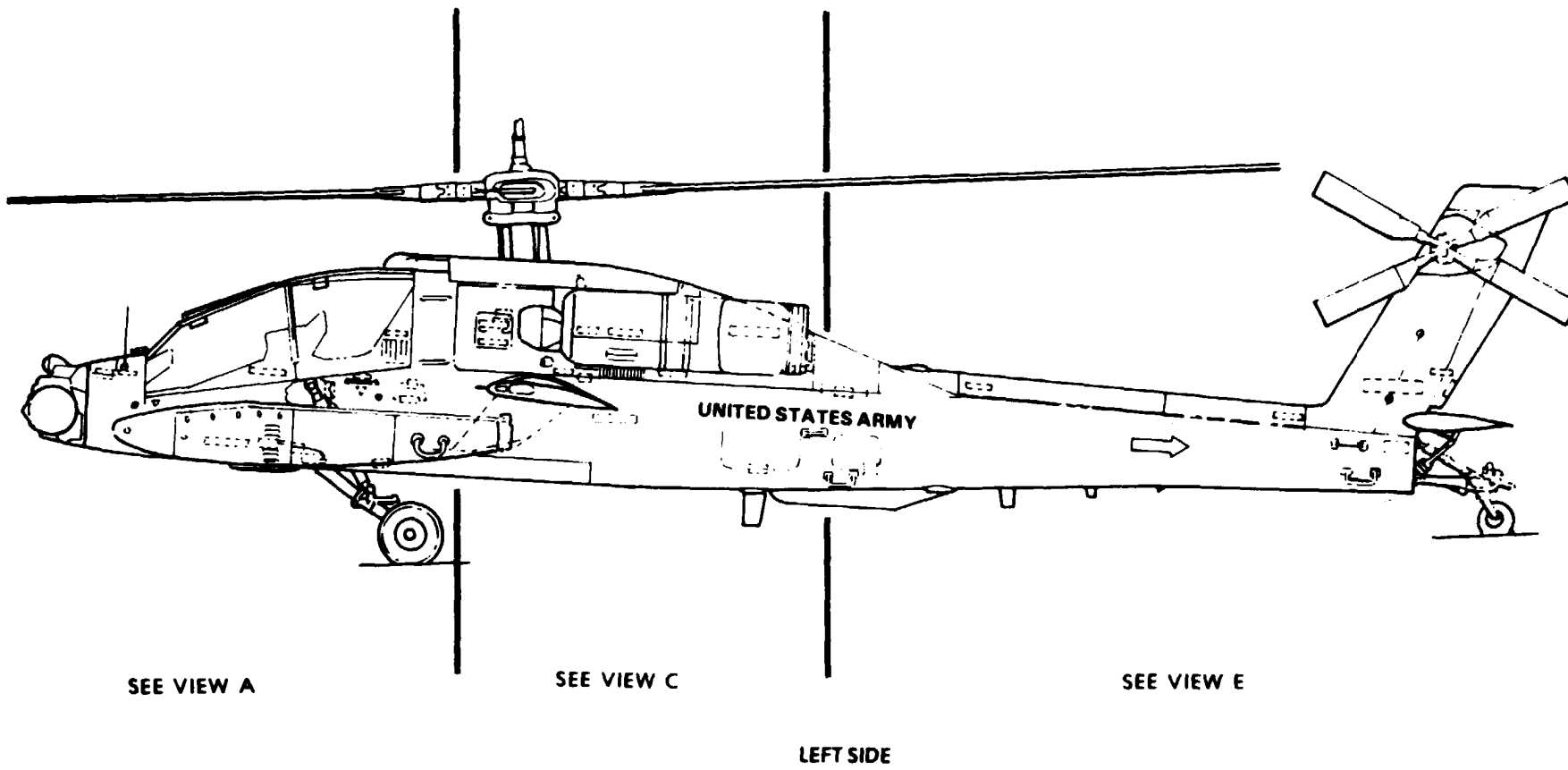
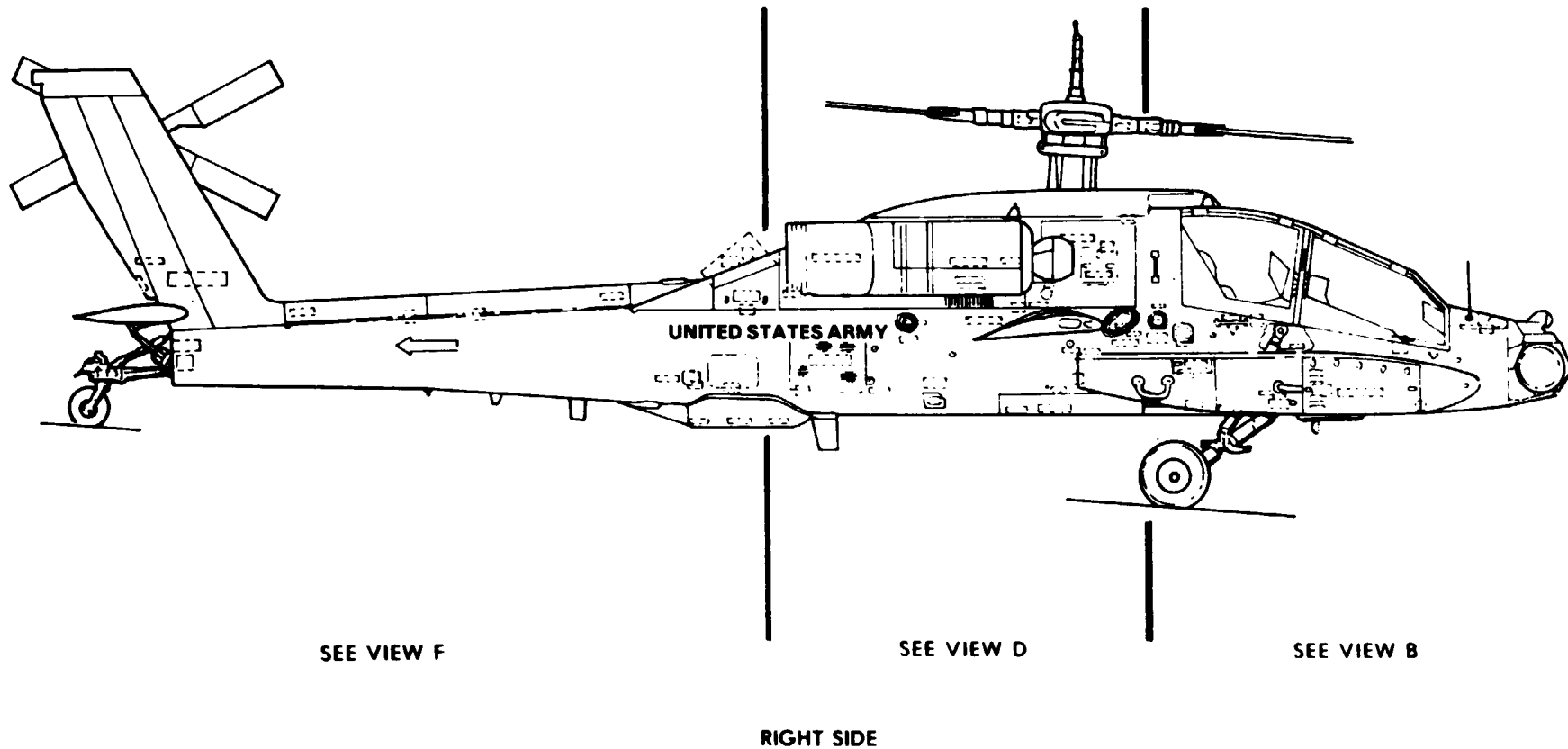


Figure 9-5. Exterior and Interior Markings, AH-64 (Sheet 1 of 19) ■



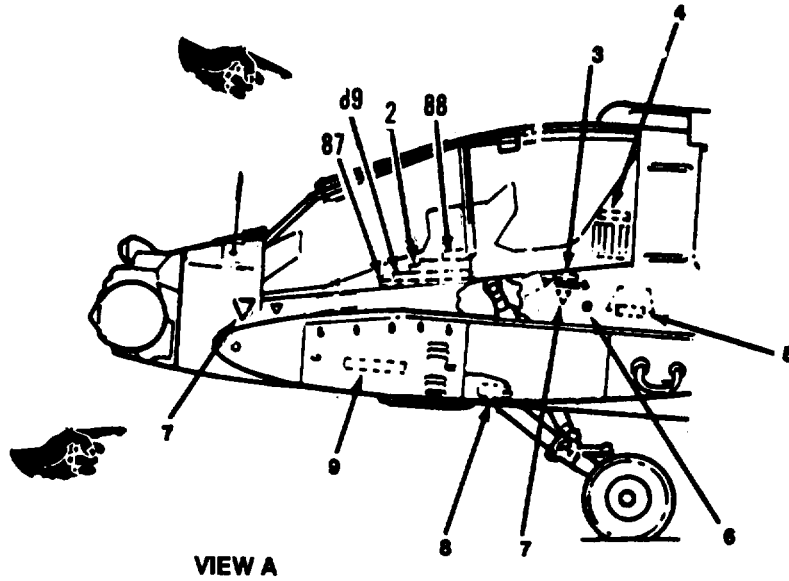
SEE VIEW F

SEE VIEW D

SEE VIEW B

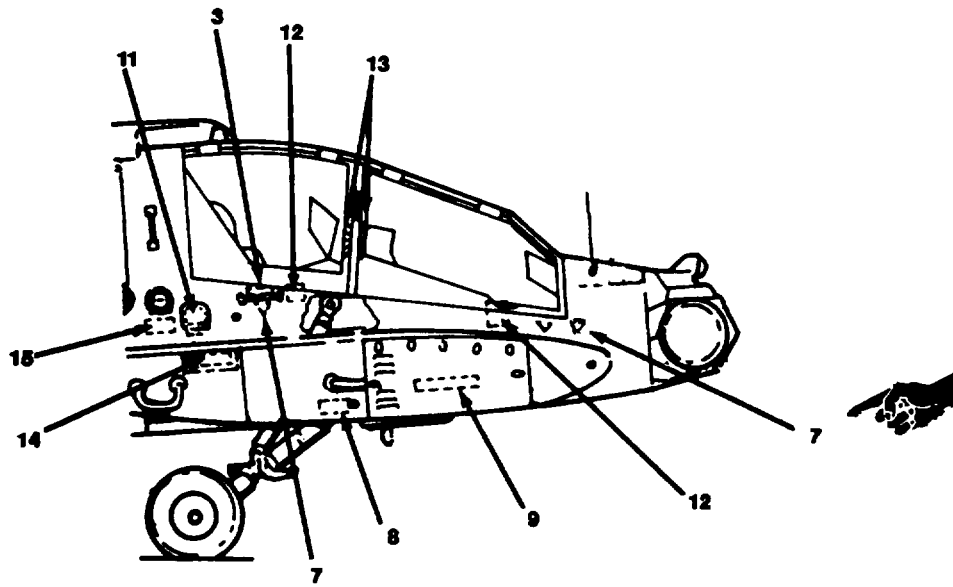
RIGHT SIDE

Figure 9-5. Exterior and Interior Markings, AH-64 (Sheet 2 of 19) ■



VIEW A

LEFT SIDE



VIEW B

RIGHT SIDE

Figure 9-5. Exterior and Interior Markings, AH-64 (Sheet 3 of 19)

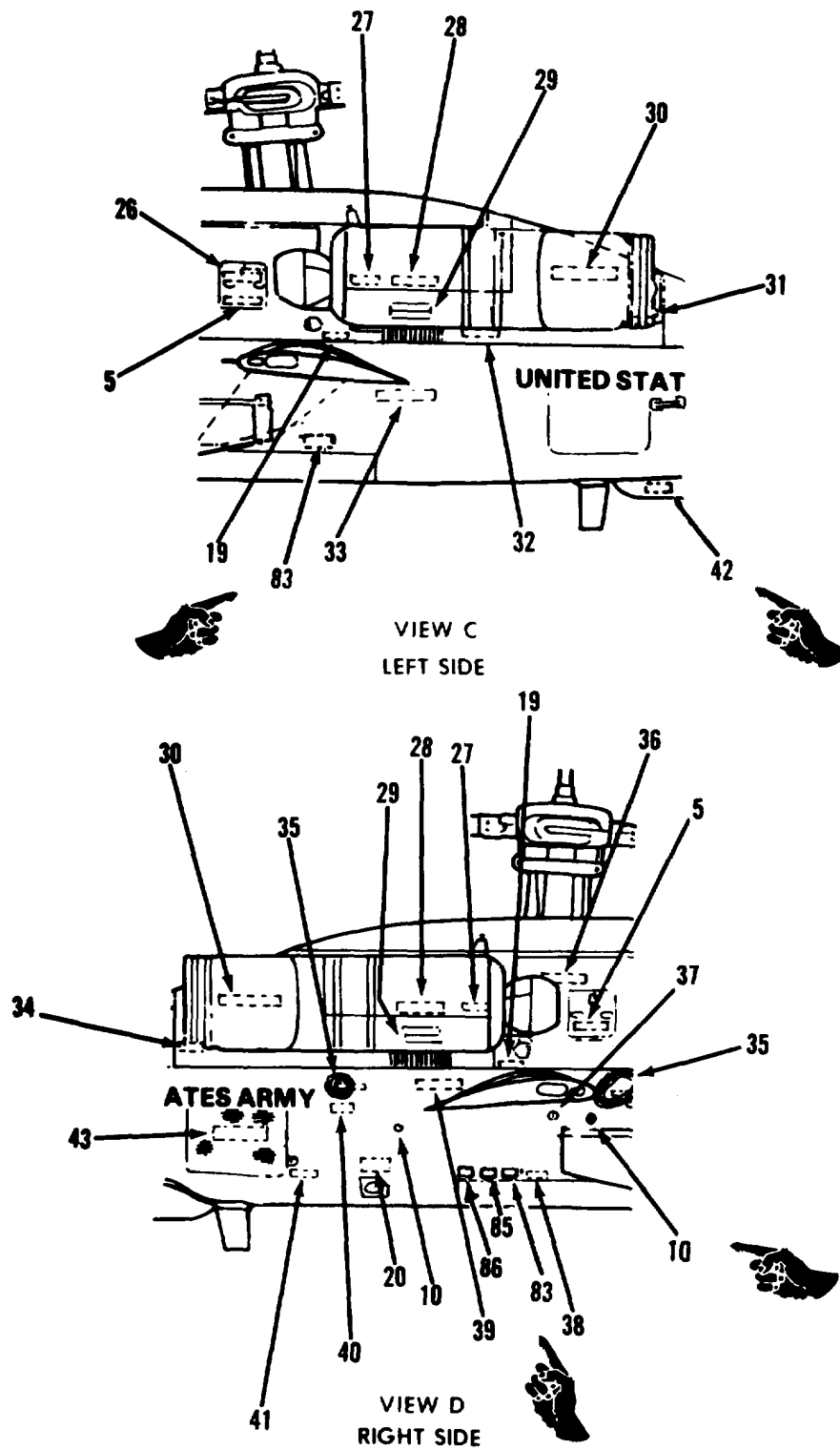


Figure 9-5. Exterior and Interior Markings, AH-64 (Sheet 4 of 19)

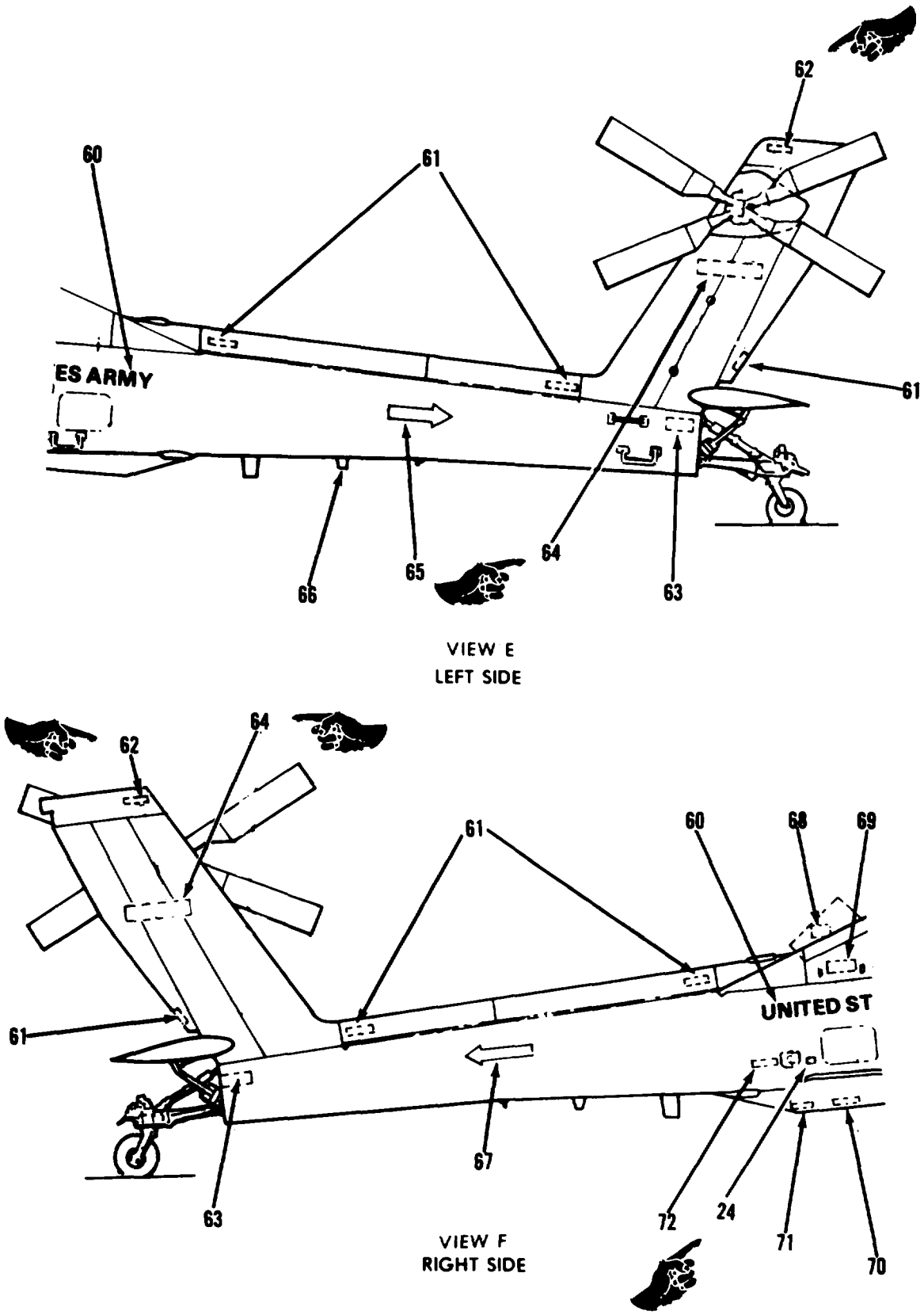


Figure 9-5. Exterior end Interior Markings, AH-84 (Sheet 5 of 19)

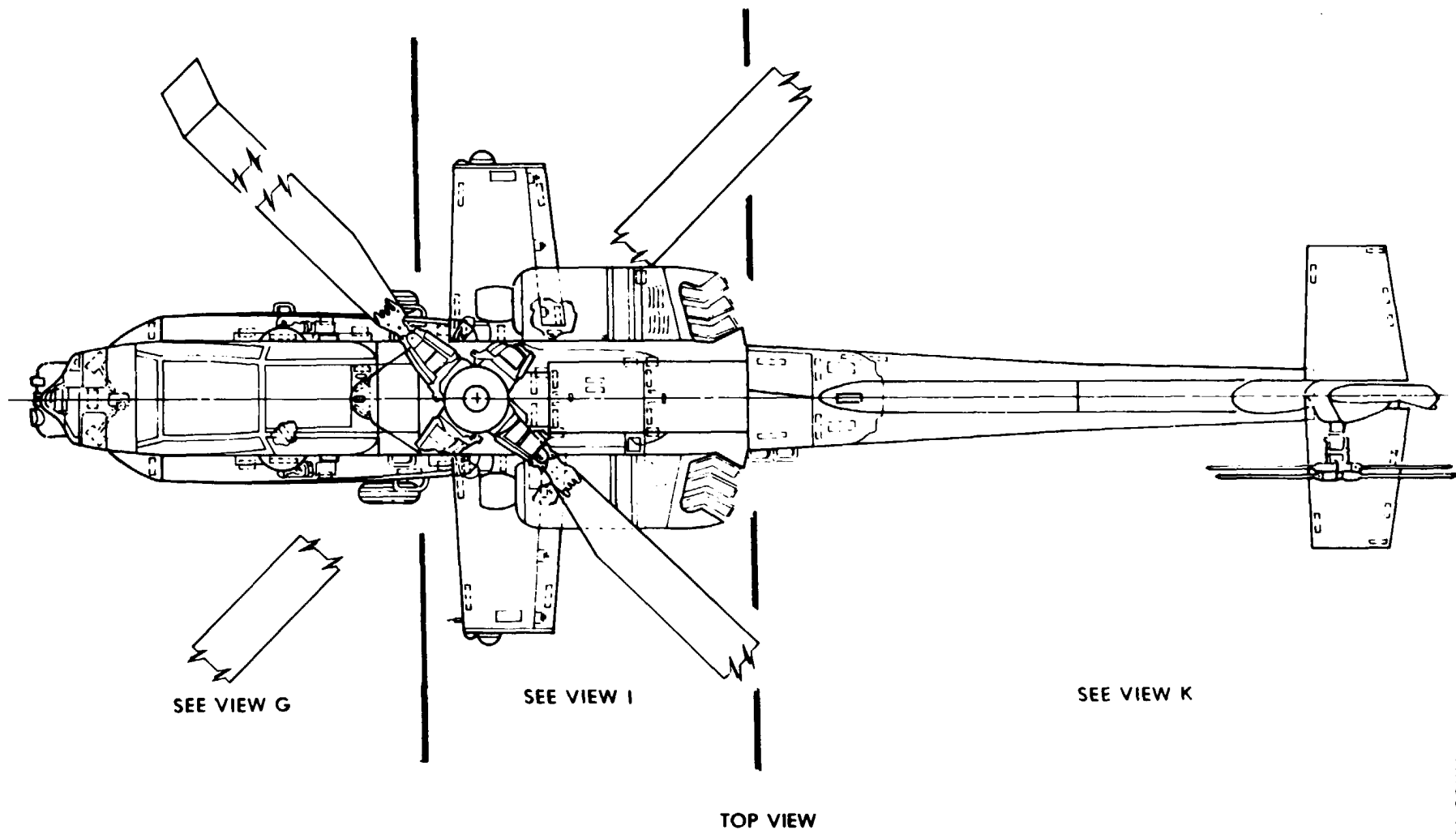


Figure 9-5. Exterior and Interior Markings, AH-64 (Sheet 6 of 19)

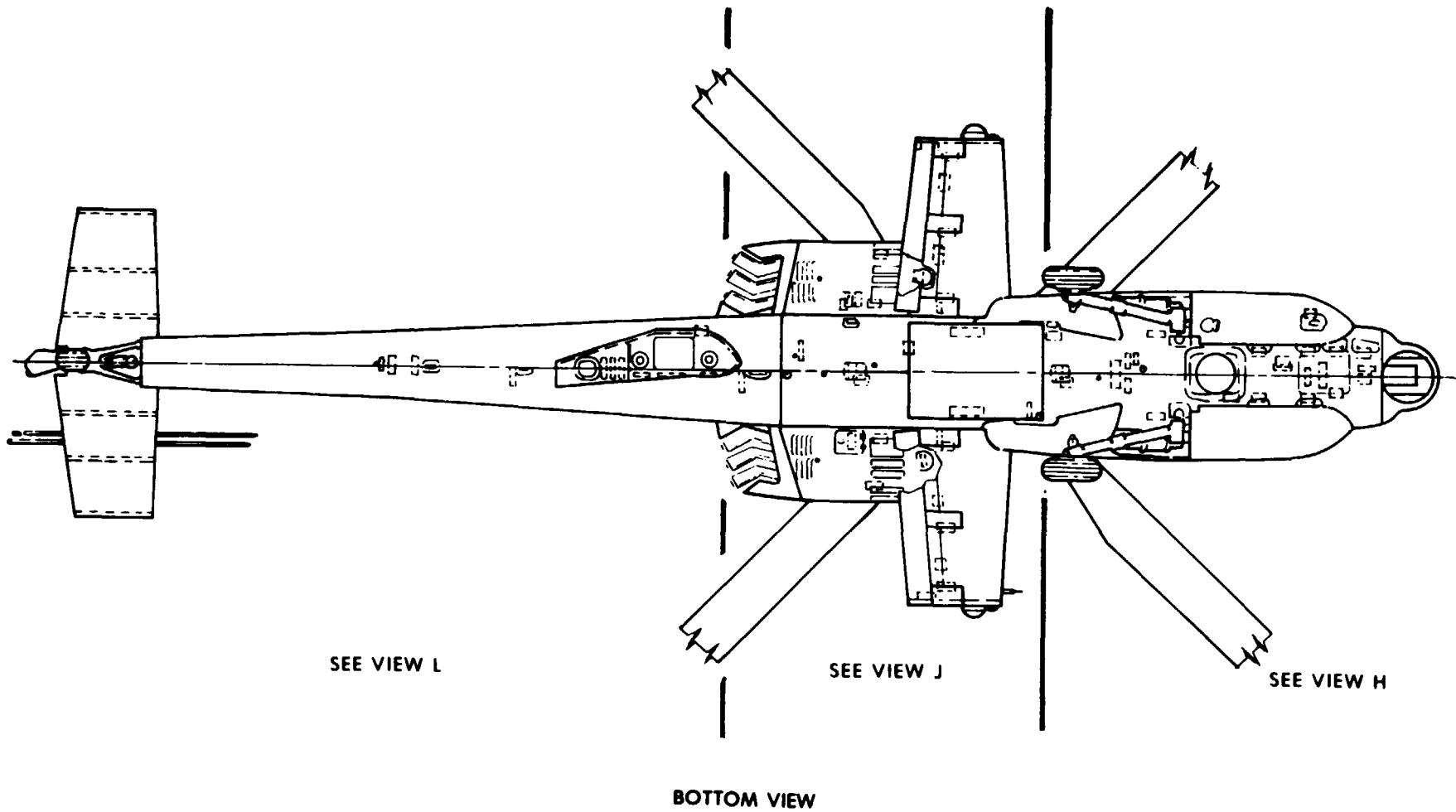


Figure 9-5. Exterior and Interior Markings, AH-64 (Sheet 7 of 19) ■

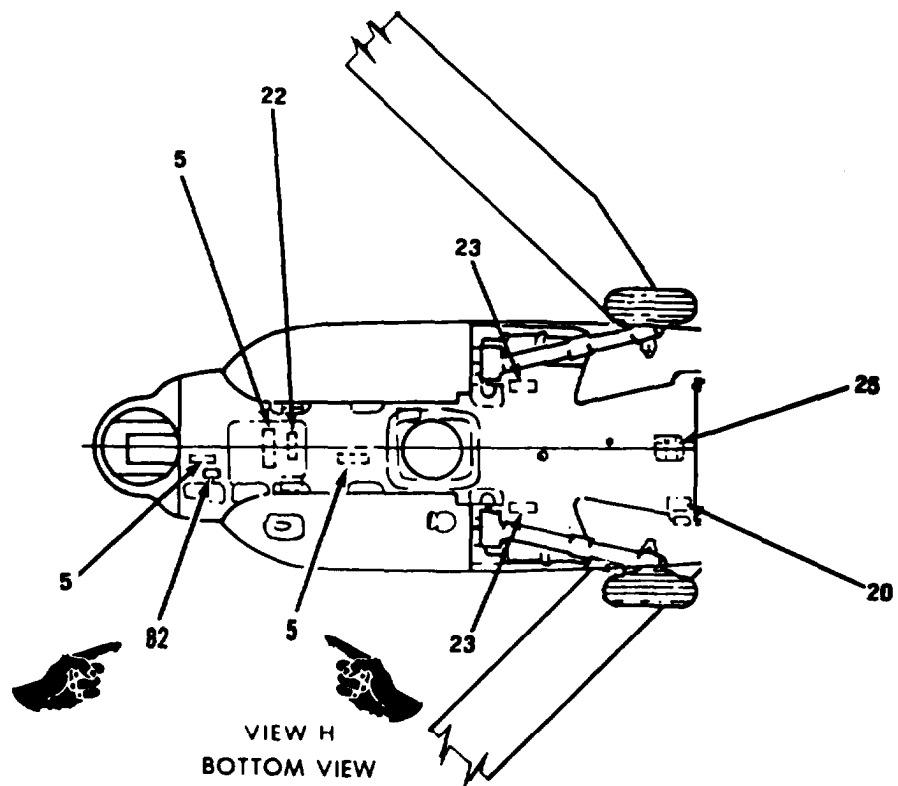
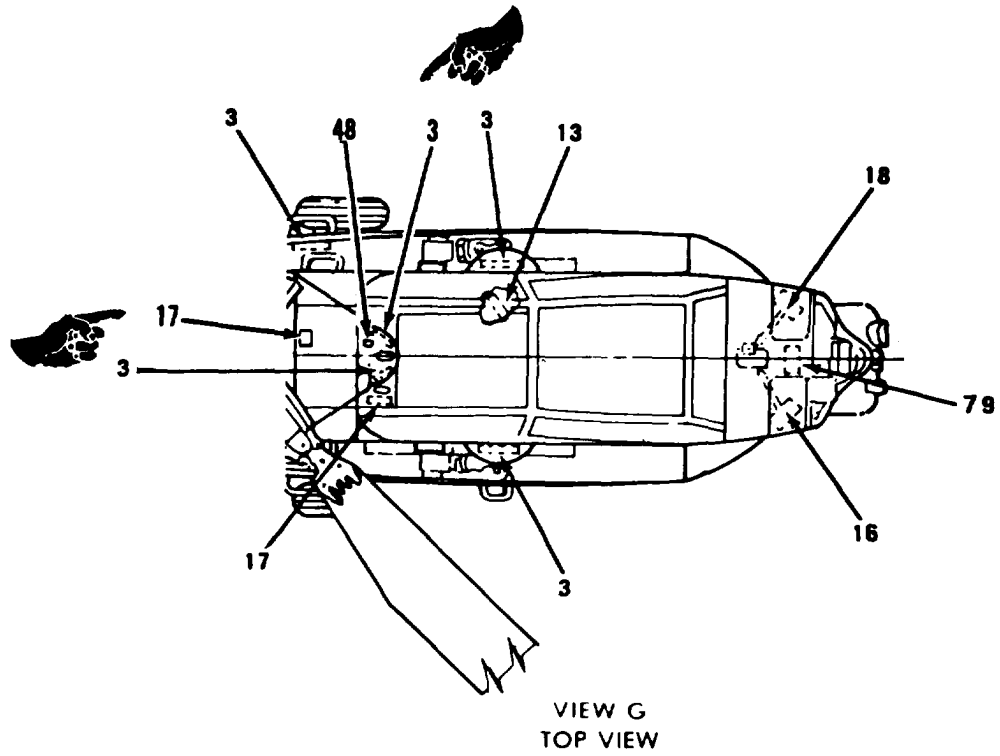


Figure 9-5, Exterior and Interior Markings, AH-64 (Sheet 8 of 19)

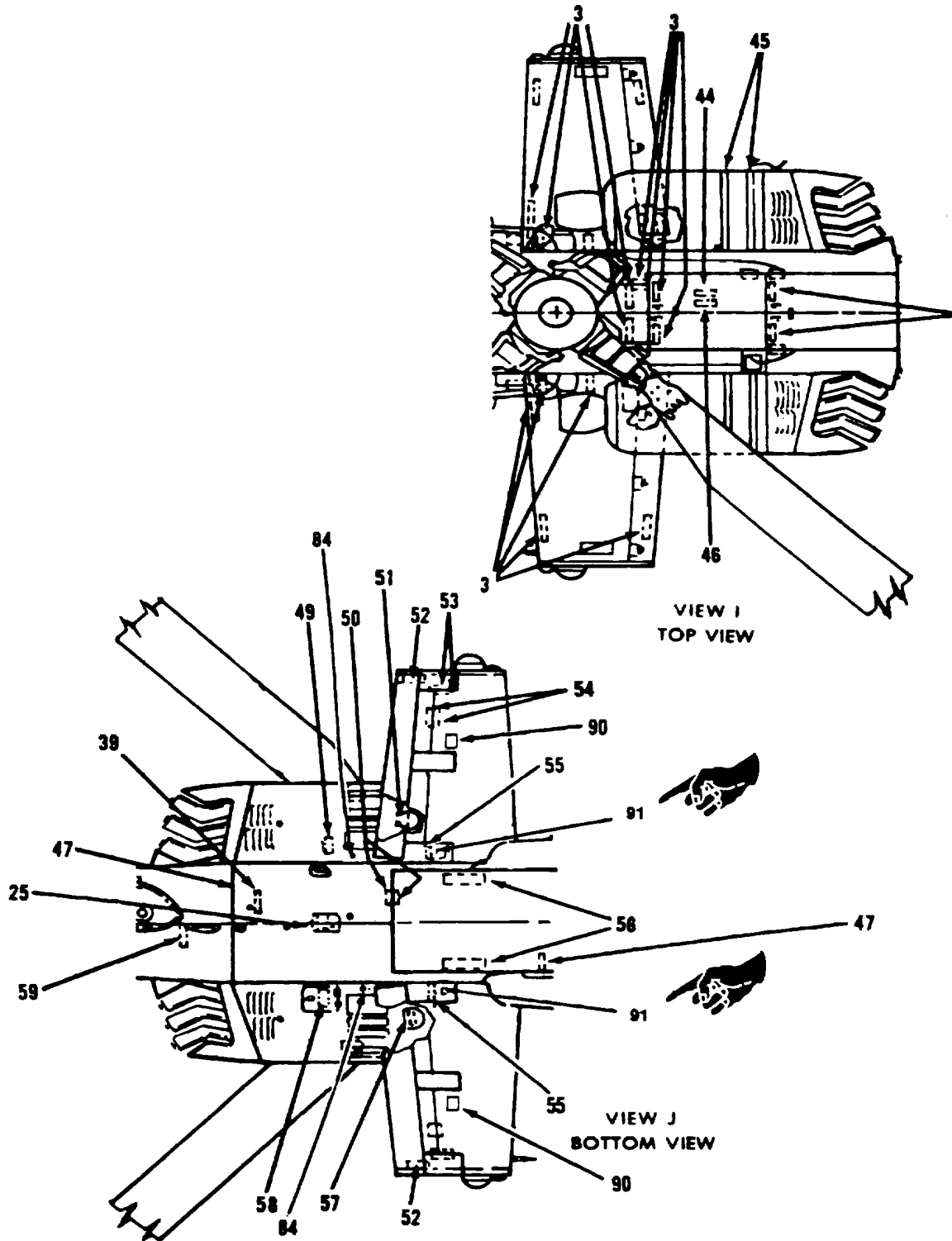


Figure 9-5. Exterior and Interior Markings, AH-64 (Sheet 9 of 19)

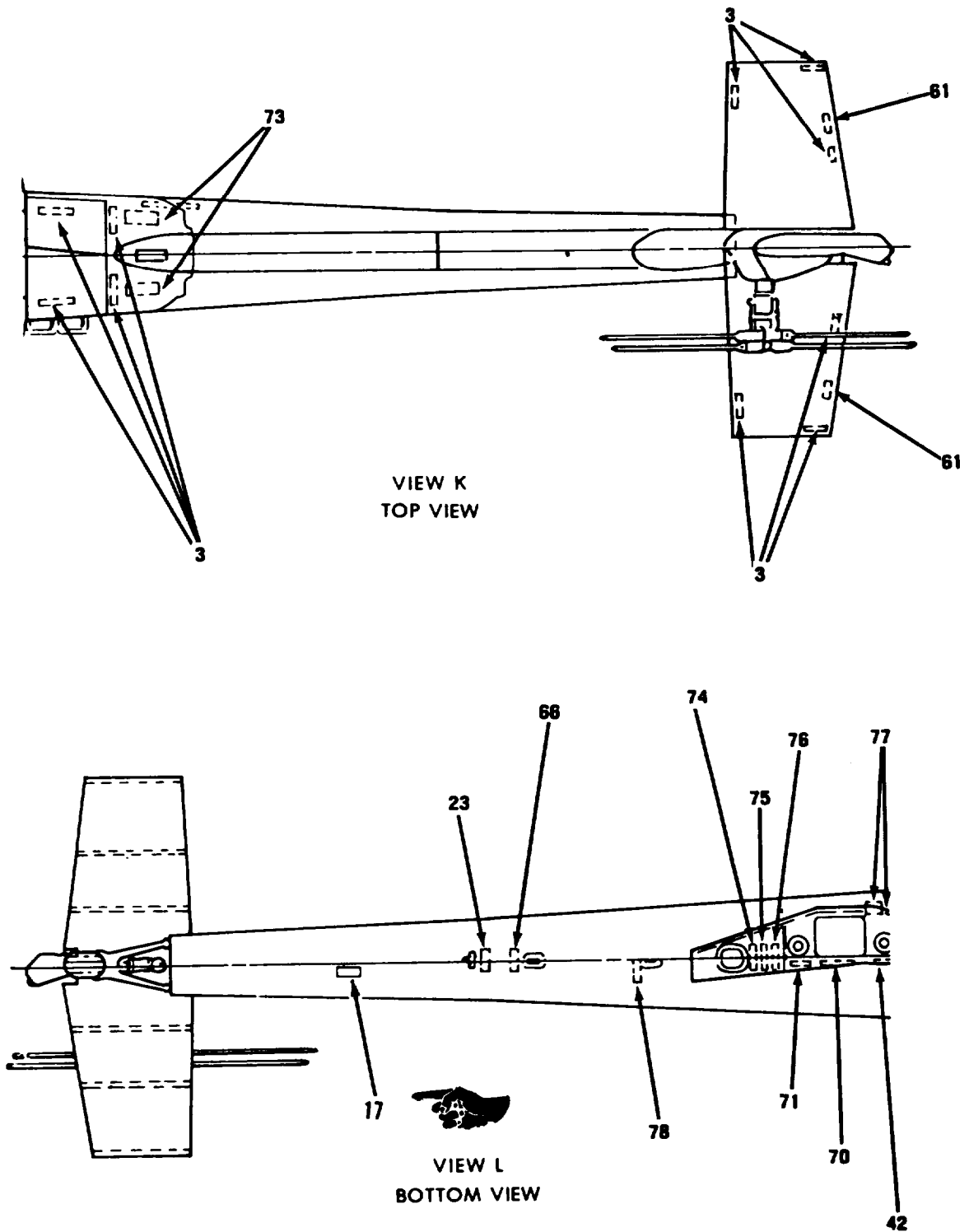
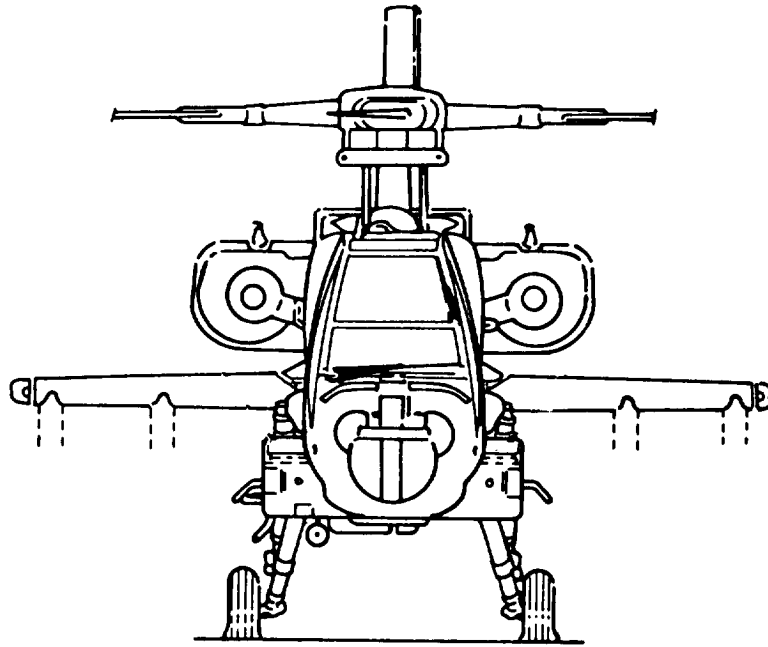


Figure 9-6. Exterior and Interior Markings, AH-64 (Sheet 10 of 19)



FRONT VIEW

Figure 9-5. Exterior and Interior Makings, AH-64 (Sheet 11 of 19)

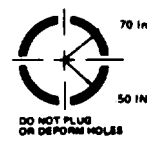
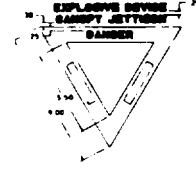

CODE NO.	DIRECTIONS	WORDING
1	Deleted	
2	LH side of canopy at FS 103.50. Locate below sill and center for best fit with Codes 87 and 89. 1-in. aircraft black letters.	Us. ARMY AH-64A U.S. A SERIAL NO. 00000
3	1/2-in. aircraft black letters, 13 required.	NO STEP
4	LH side of canopy above louvers at FS 150.00, WL 157.20, 1/2-in aircraft black letters.	EMERGENCY AIR INLET
5	LH and RH side of fuselage on transmission access doors, LH side of fuselage at FS 160.00, WL 135.00, on fuselage lower surface at FS 60.00, BL 0.00 and FS 75.00, BL 0.00, 1/2-in. aircraft black letters.	CONTROLS ACCESS
6	Both sides of fuselage at FS 147.00, WL 13500 1/4-in. aircraft black letters.	
7	Both sides of fuselage, 2 on each side at FS 65.00 and FS 140.00 1/2-in. aircraft black letters and triangle.	 <p data-bbox="1143 961 1386 1018">"DANGER" AIRCRAFT GREEN</p>
8	Both sides of fuselage on access door on ammo chute fairing at FS 120.00, 1/2-in aircraft black letters.	MOORING LUG ACCESS
9	Both avionics bays centered on doors, 1/2-in. aircraft black letters.	AVONICS BAY
10	RH side of fuselage at ground service jacks, 2 places, FS 249.830, WL 129.640 and FS 189.470, WL 129.640. (See figure 7-12 for dimensions (MIL-C-83413/9-2).	
11	RH side of fuselage above access panel at FS 155.00, WL 136.00, 1/2-in. aircraft black letters.	REFUEL CONTROL PANEL

Figure 9-5. Exterior and Interior Makings, AH-64 (Sheet 12 of 19)

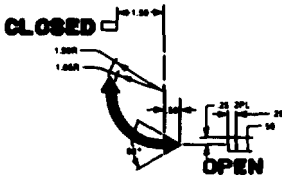
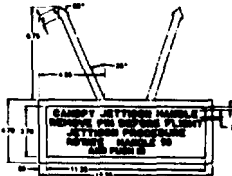
CODE/ No.	DIRECTIONS	WORDING
12	RH side of fuselage at canopy handles, aircraft black.	
13	Inside pilots's cockpit, RH side, on fwd side of CPG hold-open device, 1/2-in. aircraft black letters.	NO HOLD
14	RH side of fuselage on access door on ammo chute fairing at FS 155.00, 1/2-in. aircraft black letters.	FIRE EXTINGUISHER INSIDE
15	RH side of fuselage at fwd fuel filler cap. 1/2-in. aircraft black letters.	GRAVITY FUEL FILLER CAPACITY 155 U.S. GAL.
16	Both sides of fuselage at FS 40.00 with arrow pointing toward hatch on centerline, aircraft black.	
17	1. Centered on BL0.000 on doghouse faking assembly at FS 168.00 1/2-in, aircraft black letters. 2. Left of BL0.000, lower fuselage surface fwd of antenna at FS 468.00 1/2-in. aircraft black letters.	IFF TRANSPONDER
18	See item 16 above	
19	Both sides of fuselage on transmission access door, 1/2-in. aircraft black letters.	MAIN TRANSMISSION OIL LEVEL SIGHT GAUGE INSIDE
20	RH side of fuselage, above aft fuel drain valve and below fwd fuel drain valve, 1/2-in. aircraft black letters.	FUEL SUMP DRAIN CONTROL
21	Both sides aft FABs at FS 195.8& WL 123.65, 1/2-in. aircraft black letters.	INERTING SYSTEM VENT INSIDE

Figure 9-5. Exterior and Interior Markings, AH-64 (Sheet 13 of 19)

CODE NO.	DIRECTIONS	WORDING
22	Fwd fuselage lower surface on access hatch FS 65.00, 1/2-in. aircraft black letters.	CYCLIC STICK ACCESS
23	Bottom of fuselage, fwd of jack pads, 3 places; at FS 120.00(2 places) and FS 450.00 (1 place). 1/2-in. aircraft black letters.	JACK PAD
24	RH side of fuselage below drain at FS 312.00, WL 116.20, 1/2-in. aircraft black letters.	HYDRAULIC OVERFLOW DRAIN
25	Fuselage lower surface on access panels at FS 170.00 and FS 255.00, 1/2-in. aircraft black letters.	FUEL DUMP VALVE
26	LH side of fuselage on transmission access door. 1/2-in. aircraft black letters.	HYDRAULIC RESERVOIR OIL LEVEL SIGHT GAUGE INSIDE
27	Bottom aftside of firewall, both nacelles. 1/2-in, aircraft black letters.	ENGINE OIL LEVEL SIGHT GAUGE SERVICE ENGINE WITH MIL-L-23699 OR MIL-L-7808 OIL
28	Both nacelles, interior surface of engine fire doors below hinges. Readable when door is open. 1/2-in. aircraft black letters.	WORK PLATFORM LOAD LIMIT 400 POUNDS
29	Both nacelles on engine fire doors. 1/2-in. aircraft black letters.	ENGINE FIRE DOORS
30	Both nacelles on engine exhaust fairing. 1/2-in. aircraft black letters.	DANGER – ENGINE EXHAUST
31	Beside ECU exhaust outlet, LH side. 1/2.in. aircraft black letters.	DANGER – ECU EXHAUST
32	LH side of fuselage at FS 257.00 and WL 148.50. 1/2-in. aircraft black letters.	FIRE EXTINGUISHER DISCHARGE DISK
33	Both sides of fuselage near trailing edge of wing. 1/2-in. aircraft black letters.	CAUTION – DISCONNECT HYD. ELECTRICAL & PITOT CONNECTORS BEFORE REMOVING WING
34	Beside APU exhaust duct, RH side. 1/2-in. aircraft black letters.	DANGER – APU EXHAUST

Figure 9-5, Exterior and Interior Markings, AH-64 (Sheet 14 of 19)

CODJ NO.	DIRECTIONS	WORDING
35	Delete	
36	RH side of fuselage on transmission access panel at FS 200.00, WL 175,001/2-in. aircraft black letters.	TRANSMISSION OIL FILLER SPOUT INSIDE SERVICE TRANSMISSION WITH MIL-L-23699 OR MIL-L-7808 OIL
37	RH side of fuselage, below exhaust port at FS 202.00, WL 132.00. 1/2-in. aircraft black letters.	TRANSFER PUMP EXHAUST
38	RH side of fuselage, fwd of drain at FS 211.00, WL 116.00 1/2-in. aircraft black letters.	TRANSFER PUMP DRAIN
39	Underside of fuselage, fwd of drain at FS 278.00, RBL 6.00. 1/2-in. aircraft black letters.	FUEL BOOST PUMP DRAIN
	RH side of fuselage at aft fuel filler cap. 1/2in. aircraft black letters.	GRAVITY FUEL FILLER CAPACITY 220 U.S. GAL.
41	RH side of fuselage below exhaust port at FS 278.00. 1/2-in. aircraft black letters.	DANGER - FUEL PUMP EXHAUST PORT
42	LH side of doppler fairing at FS 315.00, top of letters at WL 104.00.	RADAR ALTIMETER RECEIVER ANTENNA
43	RH side of fuselage on access door. 1/2-in. aircraft black letters.	AFT AVIONICS BAY
44	Aft surface of main rotor mast Wing. 1/2-in. aircraft black letters.	AIR PARTICLE SEPARATOR EXHAUST
45	Both engine nacelles. 2-in. aircraft black bands.	
46	Aft surface of main rotor mast doghouse faking. 1/2-in. aircraft black letters.	SURGE VALVE EXHAUST
47	Letters centered aft of vent in ammo bay door at FS 180.00, LBL 20.00 and at FS 281.00, LBL 2.00.	FUEL VENT

Figure 9-5. Exterior and Interior Markings, AH-54 (Sheet 15 of 19)

CODE NO.	DIRECTIONS	WORDING
48	Top of doghouse fairing, LH side of antenna housing, FS 158.00. 1/2-in. aircraft black letters.	RADAR JAMMER RCVR ANTENNA
49	Bottom of RH nacelle, adjacent to sight gauge access door. 1/2-in. aircraft black letters.	APU GEARRBOX OIL LEVEL SIGHT GAUGE SERVICE GEARBOX WITH MIL-L-23699 OR MIL-L.7608 OIL
50	Underside of both nacelles at FS 237.50, BL 26.00. 1/2-in. aircraft black letters	ENGINE DRAIN
51	Underside of RH nacelle at FS 273.40, BL 26.85. 1/2-in. aircraft black letters.	APU TURBINE PLENUM DRAIN
52	Both wingtips adjacent to access door. 1/2-in. aircraft black letters.	INTER-COMM RECEPTACLE
53	Underside of RH nacelle at FS 250.75, BL 26.50. 1/2-in. aircraft black letters.	APU FUEL DRAIN
54	Underside of RH nacelle at FS 252.00, BL 26.85. 1/2-in. aircraft black letters.	APU VENT
55	Upper surface of both wings, on access panel at BL 28.00. 1/2-in. aircraft black letters.	WING ACCESS
56	Both ammo bay doors, centered at FS 205.00, bottom of letters at W L 106.00, 1/2-in. aircraft black letters.	AMMO BAY
57	Underside of both nacelles, on access panel at FS 225.00. 1/2-in. aircraft black letters.	WATER WASH ACCESS
58	Bottom of LH nacelle on access door. 1/2-in. aircraft black letters.	GROUND AIR INPUT
59	Lower fuselage surface, centered aft of blade antenna at FS 355.00. 1/2-in. aircraft black letters.	VHF AM/FM NO. 2
60	Both sides of fuselage, most fwd letter ("U" left side, "Y" right side) at FS 271.00, tops of letters at WL 137.50, aircraft black letters	UNITED STATES ARMY 6 INCH HIGH 4 INCH WIDE DISTANCE BETWEEN LETTERS 1 INCH, DISTANCE BETWEEN WORDS 4 INCH.

Figure 9-5. Exterior and Interior Markings, AH-64 (Sheet 16 of 19)

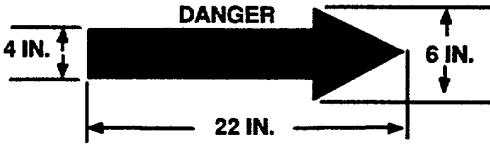
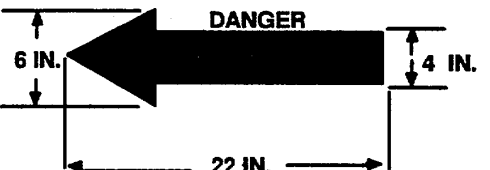
CODE NO.	DIRECTIONS	WORDING
61	Both sides to tail cone, vertical stabilizer, and drive shaft fairing. 1/2-in. aircraft black letters.	NO PUSH
62	Both sides of vertical stabilizer at FS 560.00 and WL 240.00 in 1/2-in. aircraft black letters.	VHF AM/FM NO. 1
63	Both sides of tailboom, 2 in. fwd of tail cone separation. 1/2-in. aircraft black letters.	CAUTION — UNLOCK TAIL WHEEL BEFORE TOWING
64	Both sides of vertical stabilizer, most aft number start at FS 561.65, bottom of numbers at WL 178.1 in aircraft black letters. Numbers 6-in. high, 4-in. wide and 1-in. between letters.	(Radio Call Numbers)
65	LH side of aft fuselage, center of arrow at WL 133.00, point of arrow at FS 461.00. Aircraft black arrow and letters.	
66	Lower fuselage surface aft of antenna at FS 426.1. 1/2-in. aircraft black letters.	RADAR WARNING BLADE
67	RH side of aft fuselage, center of arrow at WL 133.00, point of arrow at FS 461.00. Aircraft black arrow and letters.	
68	Interior surface of access door, oriented to be readable when door is in open position. 1/2-in. aircraft black letters	DO NOT OPERATE ROTOR OR APU WITH GSE CONNECTED
69	RH side of fuselage, on access door in aft fairing. 1/2-in. aircraft black letters.	HYDRAULIC GROUND SERVICE PANEL SERVICE HYD SYSTEM WITH MIL-H-5606 OR MIL-H-83282
70	LH side of doppler fairing at FS 330.00, top of letters at WL 104.00. 1/2-in. aircraft black letters.	DOPPLER RADAR

Figure 9-5. Exterior and Interior Markings, AH-64 (Sheet 17 of 19)

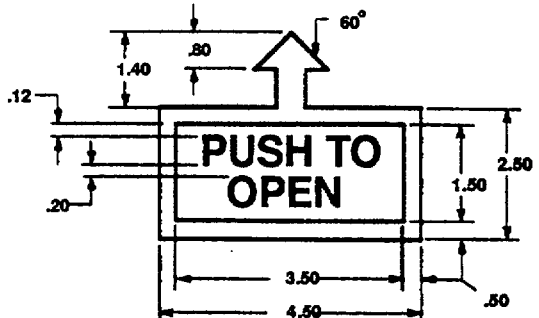

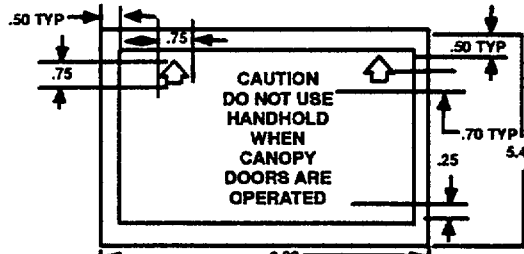
CODE NO.	DIRECTIONS	WORDING
71	LH side of doppler fairing at FS 345.00, top of letters WL 104.00. 1/2-in. aircraft black letters.	RADAR ALTIMETER XMTR ANTENNA
72	RH side of fuselage aft of access door at FS 344.00. 1/2-in. aircraft black letters.	EXTERNAL POWER CONNECTOR — 115VAC/DC 3PH 400HZ
73	Both sides of aft fairing upper surface. 1/2-in. aircraft black letters.	CAUTION — DISCONNECT ELECTRICAL CONNECTORS BEFORE REMOVING FAIRING
74	Lower fuselage surface aft on antenna fairing at FS 355.00. 1/2-in. aircraft black letters.	ADF LOOP ANTENNA
75	Lower fuselage surface aft on antenna fairing at FS 355.00. 1/2-in. aircraft black letters.	ADF SENSE ANTENNA
76	Lower fuselage surface aft on antenna fairing at FS 355.00. 1/2-in. aircraft black letters.	ADF AMPLIFIER IMPEDANCE MATCHING
77	Locate aft of drains at FS 133.36, LBL 1.60; FS 152.10, RBL 1.60; FS 245.47, RBL 1.60; FS 267.06, RBL 1.20. 1/2-in. aircraft black letters, 4 places.	FUEL DRAIN
78	Lower fuselage surface aft of antenna blade at FS 393.00. 1/2-in. aircraft black letters.	UHF/IFF TRANSPONDER
79	Locate on centerline of aircraft, top of nose at FS 39.00. 1/2-in. aircraft black letters and border.	
80	Marking on pilot and co-pilot/gunner collective stick chop collar will have black letters on orange-yellow background.	
81	Forward upper corner of right hand ammo chute fairing at approximately FS 115.00 and WL 128.00. 1/2-in. aircraft black letters and border.	

Figure 9-5. Exterior and Interior Markings, AH-64 (Sheet 18 of 19)

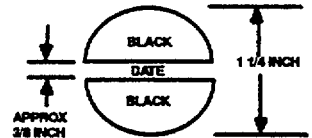
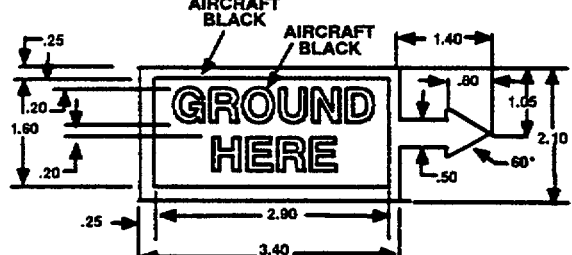
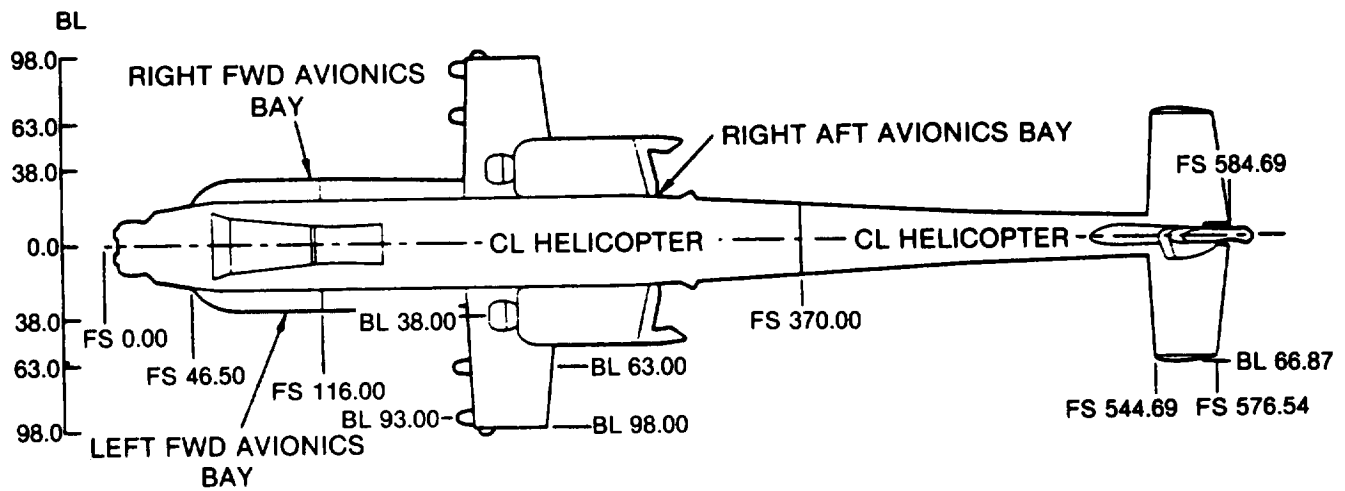
CODE NO.	DIRECTIONS	WORDING
82	RH underside at FS 87.00 adjacent to access door, 1/2-in. aircraft black letters.	UTILITY LIGHT & GROUND POWER RECEPTACLE
83	LH side and RH side of fuselage at WL 114.87, FS 220.62 (one marking under both drains) 1/2-in. black letters.	TRANSMISSION DRAINS
84	On underside of both nacelles, outboard of drain LBL 26.50, FS 245.00 and RBL 26.50, FS 244.50. 1/2-in. aircraft black letters.	COMBUSTOR DRAIN
85	RH side of fuselage at WL 114.44, and FS 223.65. 1/2-in. aircraft black letters.	AIR SEPARATOR DRAIN
86	On RH side of fuselage at WL 114.50, FS 228.12. 1/2-in. aircraft black letters.	APU PUMP DRAIN
87	LH side of canopy at FS 103.00 below Code 89, 1/4-in. aircraft black letters. WP -Indicates wash primer used P -Indicates primer used L -Indicates lacquer used (if required) C -Indicates coating used (if required)	
88	LH side of canopy at FS 105.00 above Code 2. 1/4-in. aircraft black letters. NOTE: Date shown on stencil is date aircraft painted with MIL-C-46168 paint.	
89	On LH side of canopy at FS 103.50 below Code 2. 1/2 in. aircraft black letters.	SERVICE THIS AIRCRAFT WITH MIL-T-5624 GRADE JP4 OR JP5 AVIATION FUEL. IF NOT AVAILABLE, REFER TO TB 55-9150-200-24 FOR ALTERNATE FUEL.
90	On underside of LH and RH wing assembly, centered on WG STA 31.570 with arrow pointing inboard towards ground service jack. Arrow tip should end 1-in from ground service jack (BL 66.540). Aircraft black letters.	
91	LH and RH wings upper surface at FS 228.00, BL 28.00. 1/2-in. aircraft black letters.	AUX FUEL SYSTEM QUICK DISCONNECT

Figure 9-5. Exterior and Interior Markings, AH-64 (Sheet 19 of 19)



ALL DIMENSIONS ARE IN INCHES

BL BUTTLINE

CL CENTERLINE

FS FUSELAGE STATION

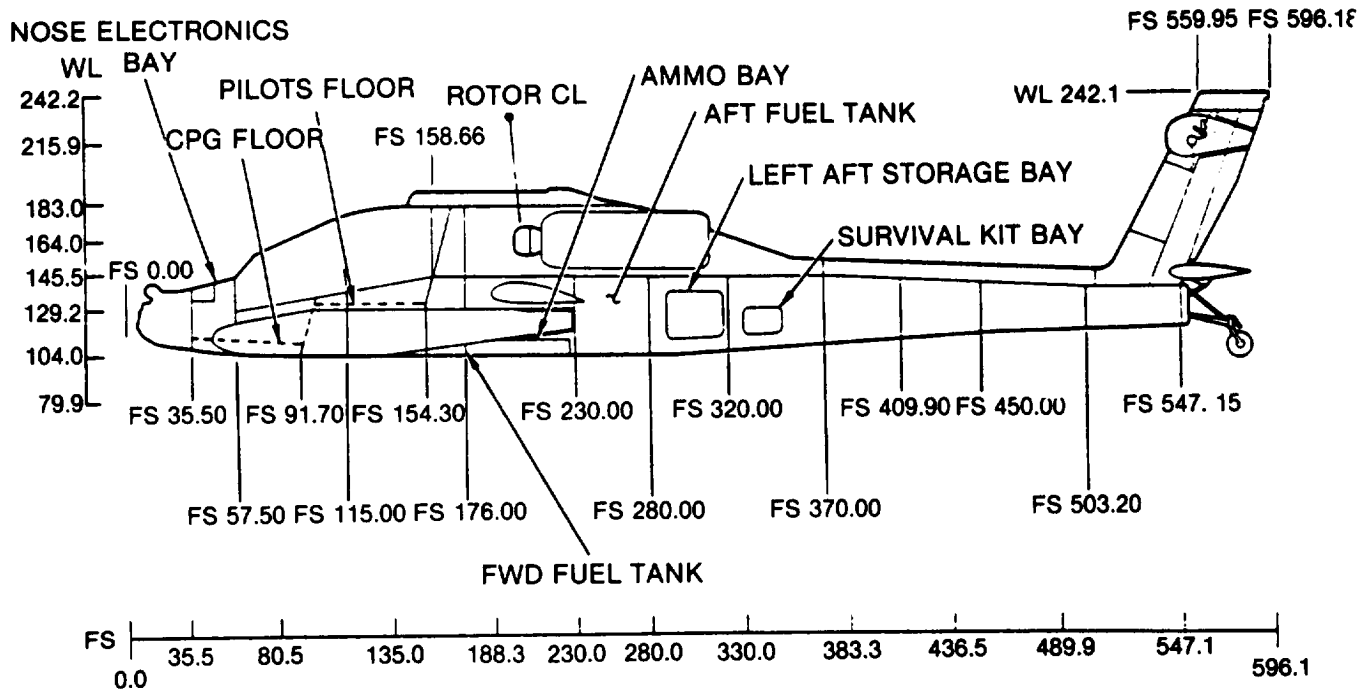
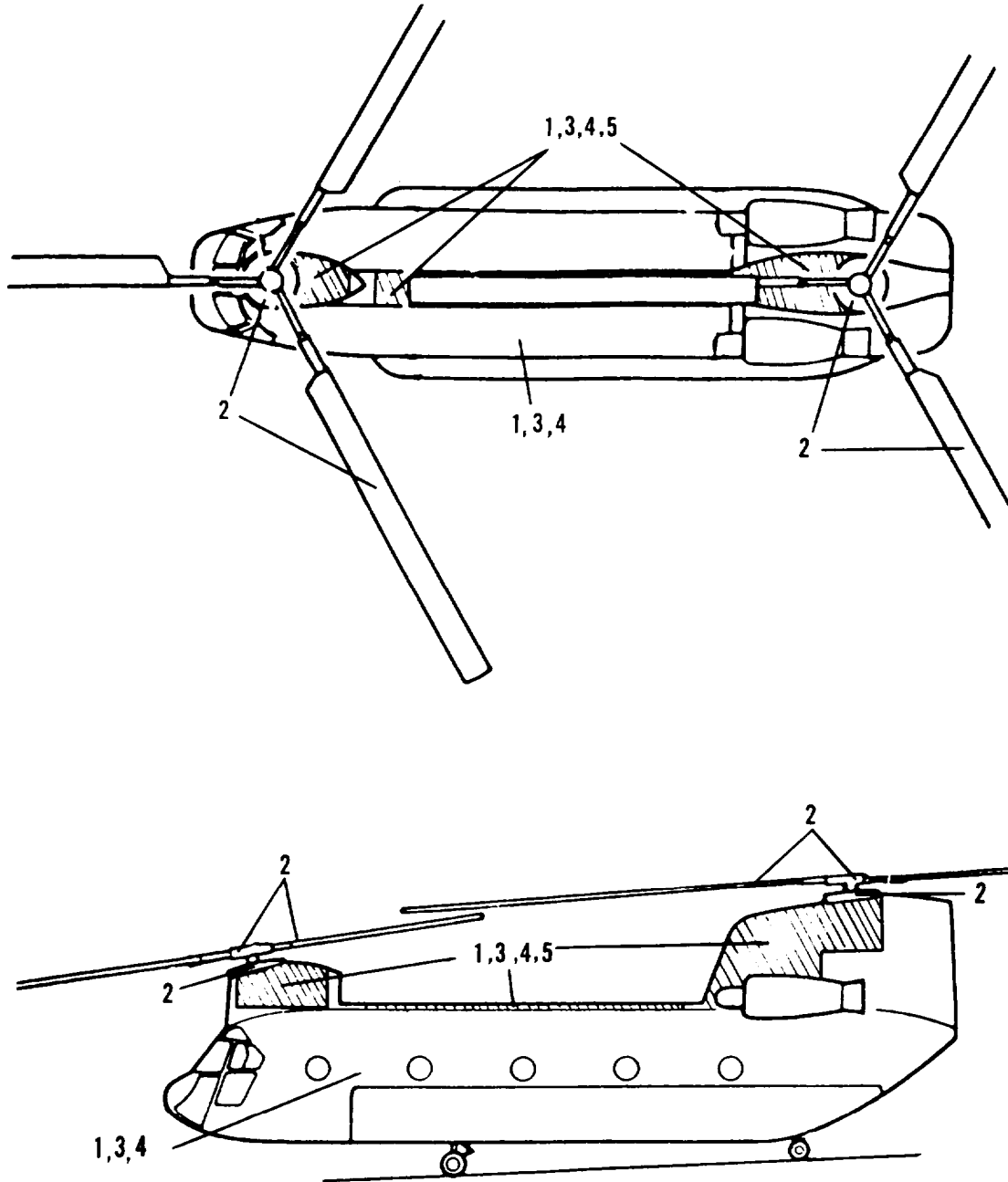


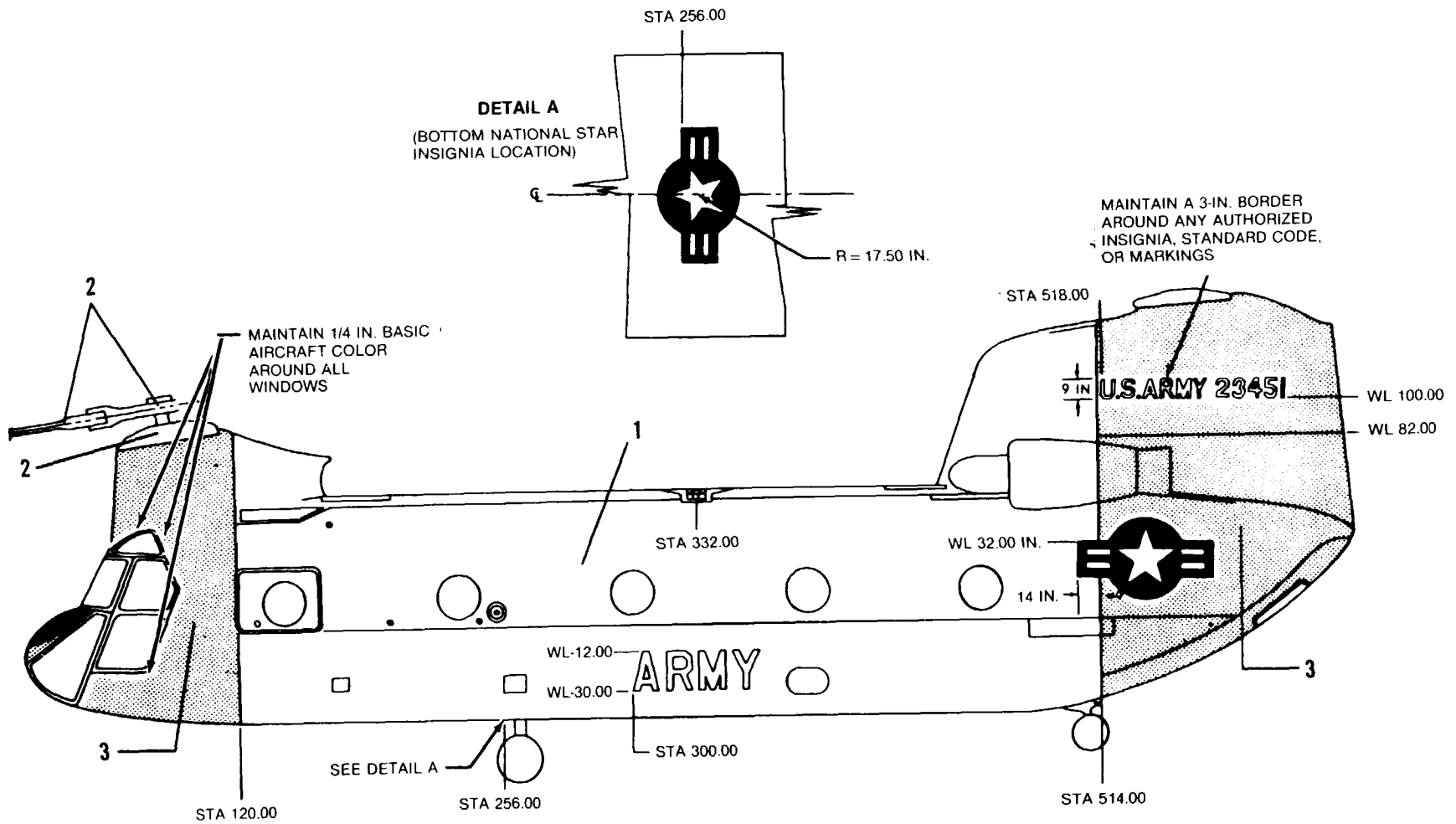
Figure 9-6. Station Diagram, AH-64

Section III. CH-47 Illustrations



1. MIL-C-46168, Aircraft Green (entire aircraft, except as noted).
2. MIL-C-46168, Aircraft Black.
3. MIL-C-46168, Dark Sand (entire aircraft or high conspicuous paint scheme when authorized, desert operations only). See Paragraph 5-11.
4. MIL-C-46168, Aircraft White (entire aircraft or high conspicuous paint scheme when authorized, arctic operations only). See Paragraph 5-11.
5. MIL-P-21600, Fluorescent Red-Orange. ANA #633 (training aircraft-high visibility, only where authorized).

Figure 9-7. Tactical Paint Scheme. CH-47



1. MIL-C-46168, aircraft green (entire aircraft, except where noted).
2. MIL-C-46168, aircraft black.
3. MIL-P-21600, fluorescent red-orange, ANA #633 (shaded areas only).

Figure 9-8. Non-Tactical Arctic/Desert Paint Scheme, CH-47

NOTE

ENTIRE INTERIOR OF HELICOPTER TO BE INTERIOR AIRCRAFT GRAY, EXCEPT SURFACES ABOVE WATERLINE PLUS 29.0 TO BE APPLICABLE PRIMER COLOR ONLY.

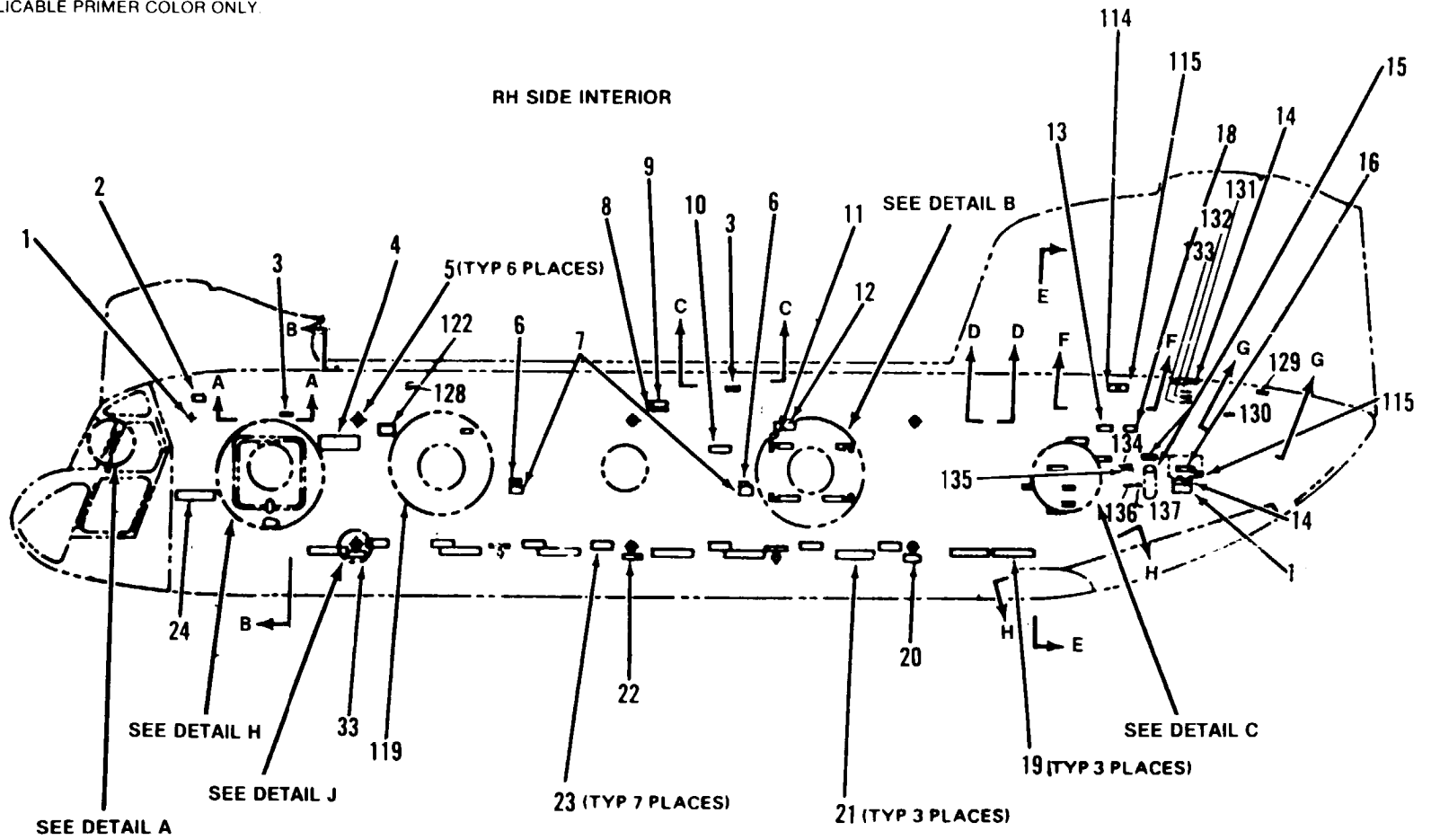


Figure 9-9. Interior Markings, CH-47 (Sheet 1 of 20)

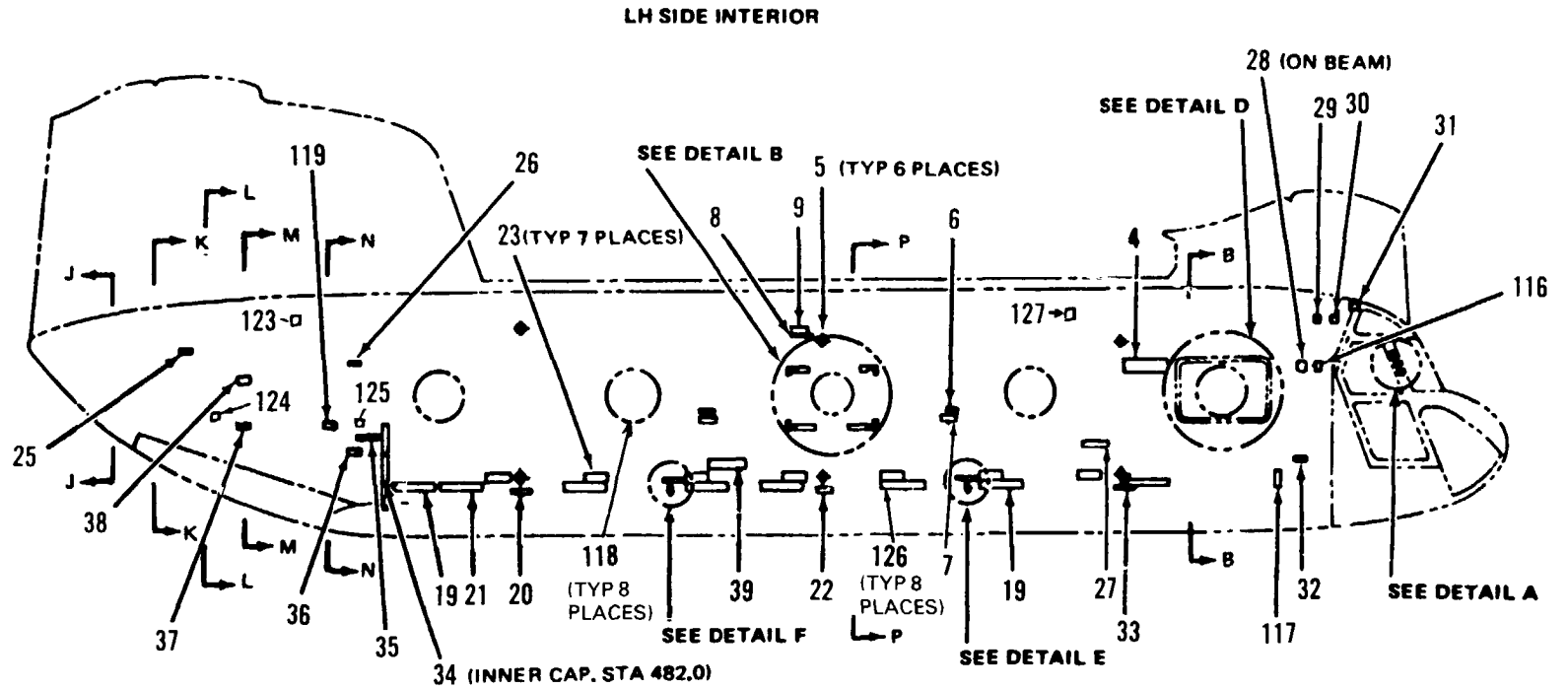


Figure 9-9. Interior Markings, CH-47 (Sheet 2 of 20)

COCKPIT AND CABIN
(LOOKING DOWN)

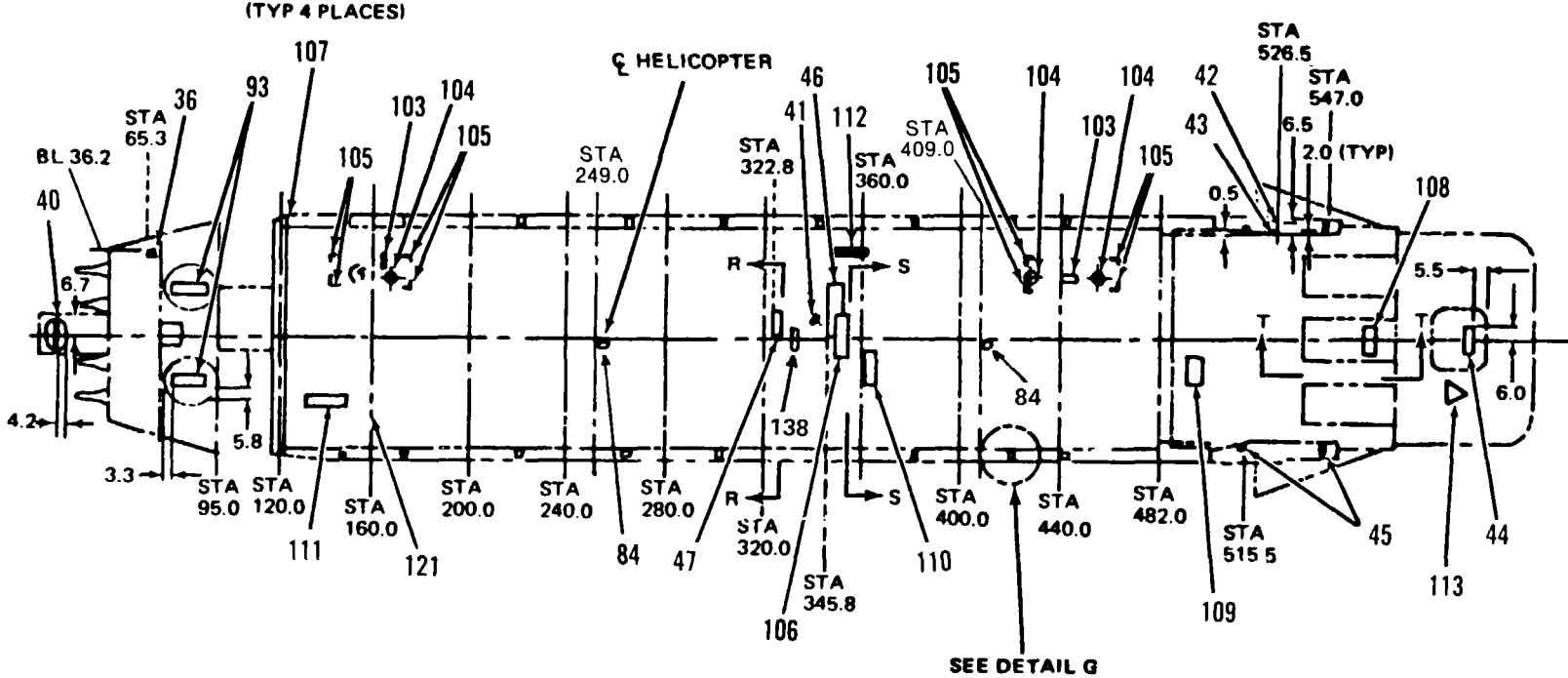


Figure 9-9. Interior Markings, CH-47 (Sheet 3 of 20)

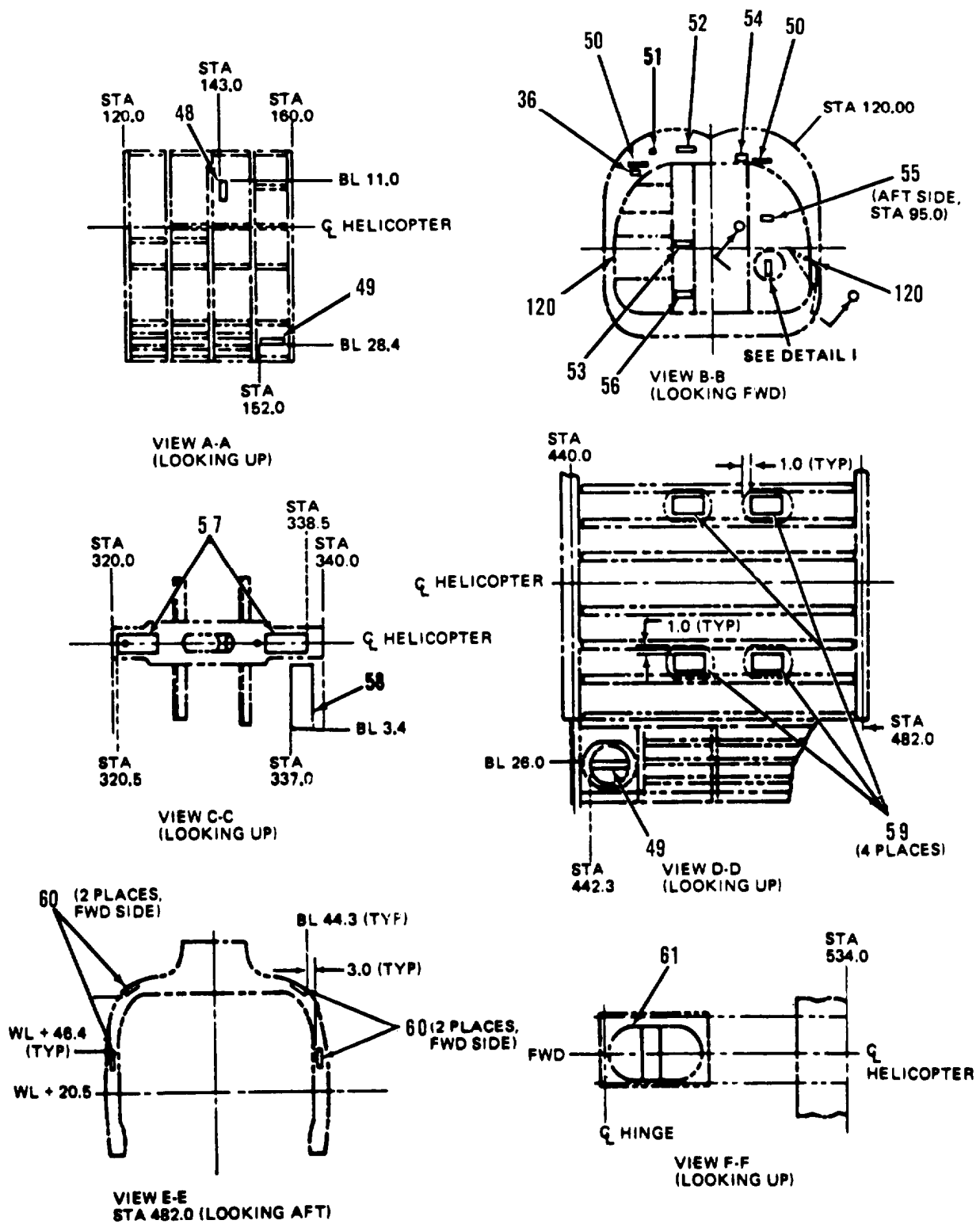


Figure 9-9. Interior Markings, CH-47 (Sheet 4 of 20)

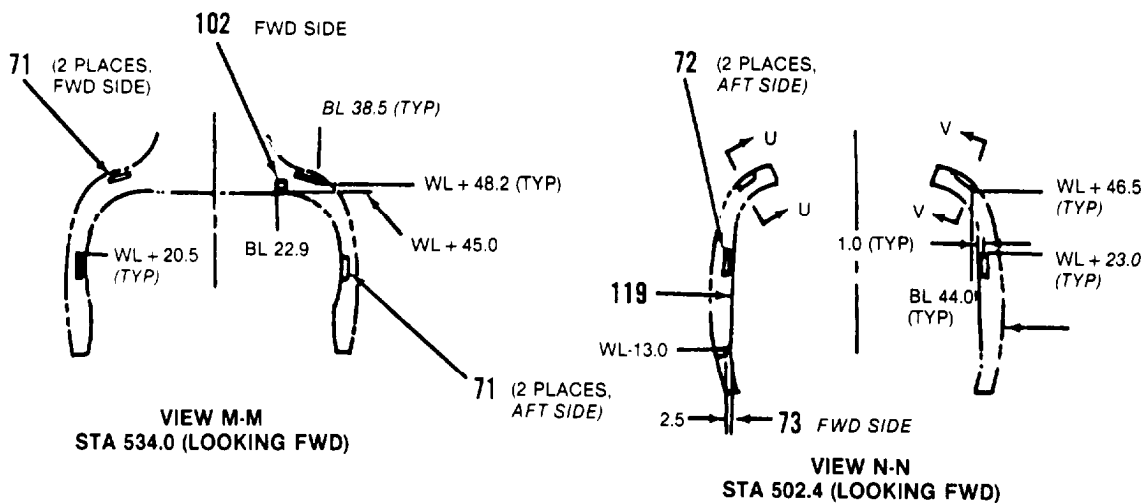
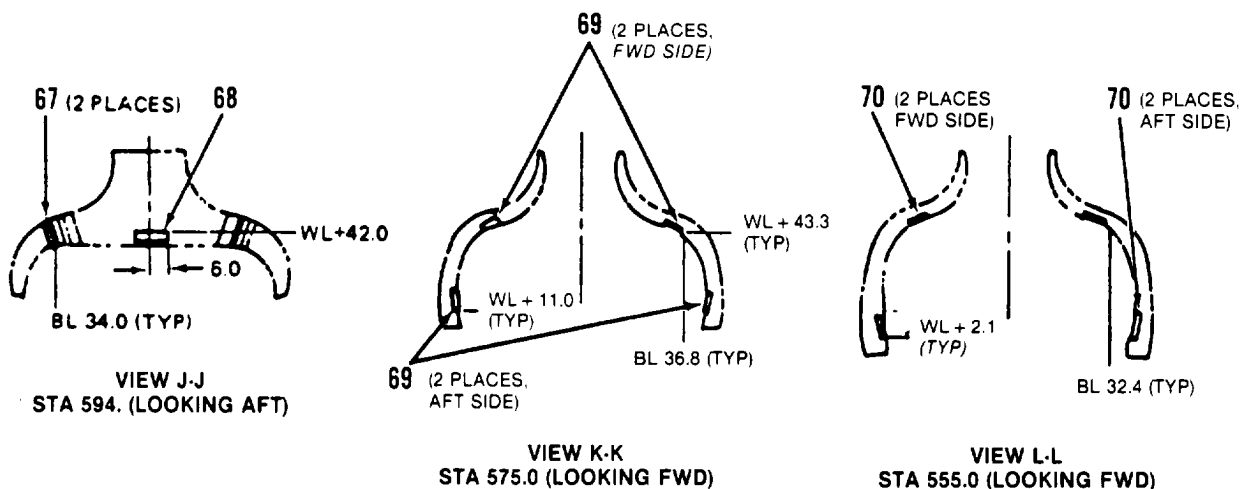
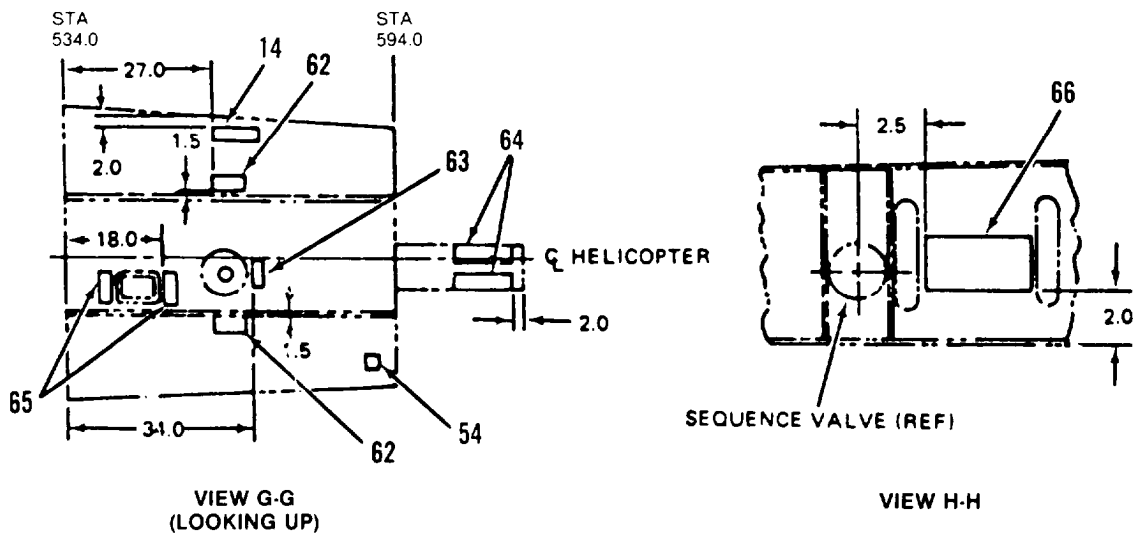
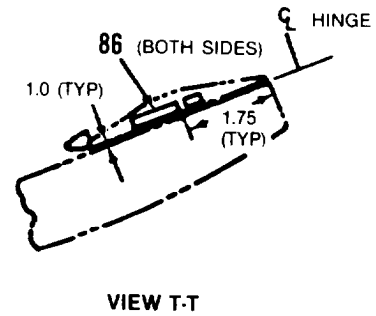
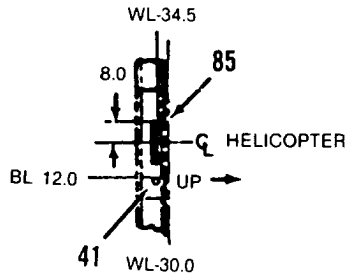
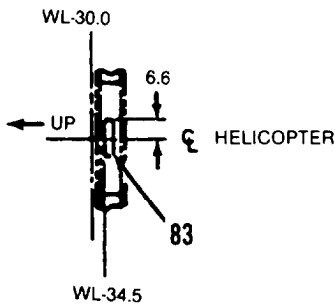
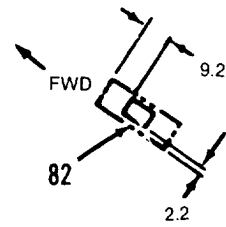
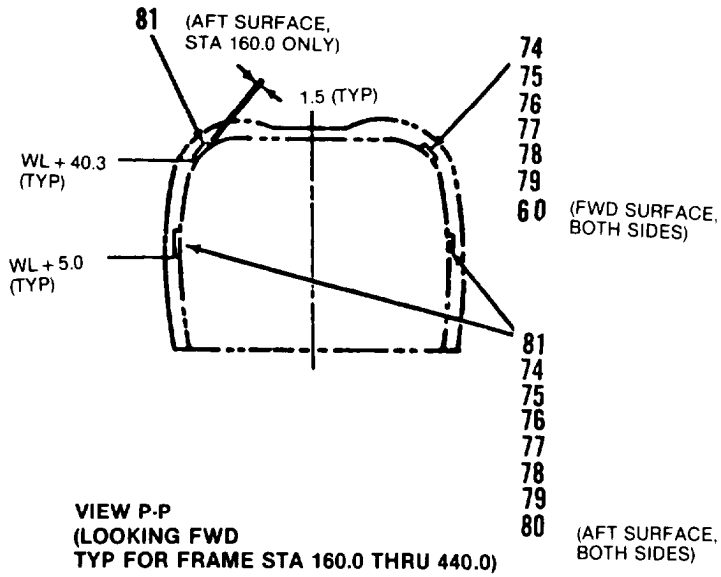


Figure 9-9. Interior Markings, CH-47 (Sheet 5 of 20)



REFER TO PARAGRAPH
7-22, EFF-59-4938
THROUGH 59-4986, AND
60-3448 THRU
64-13116

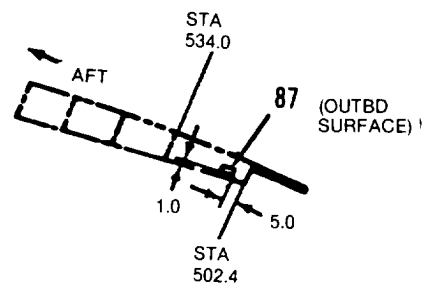
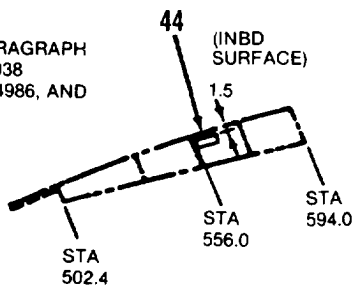
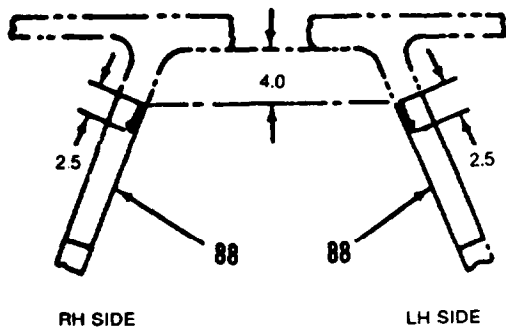
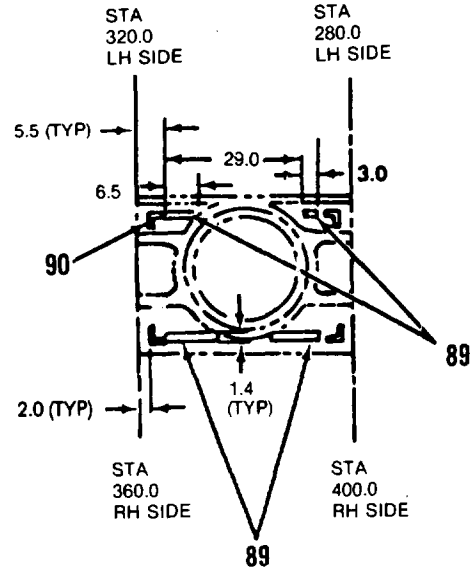


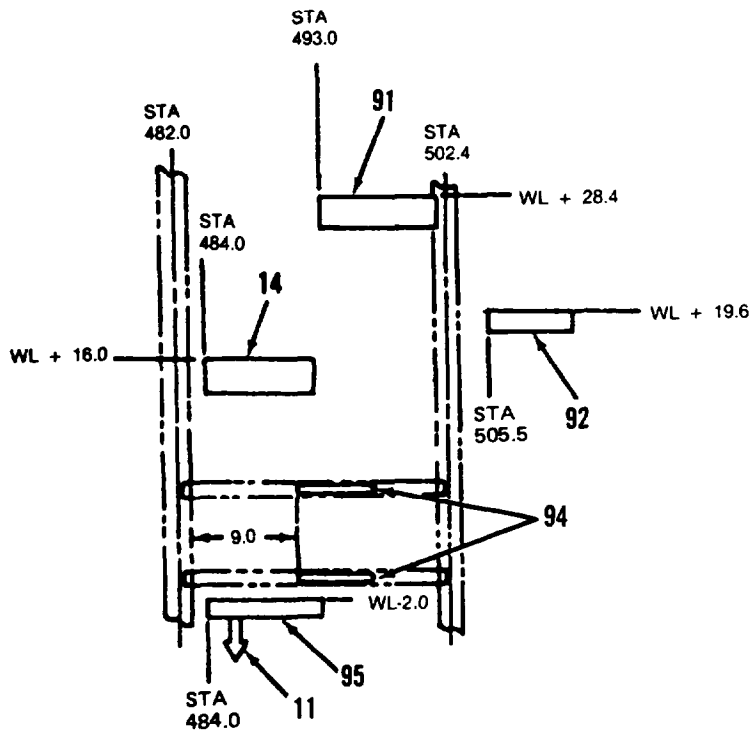
Figure 9-9. Interior Markings, CH-47 (Sheet 6 of 20)



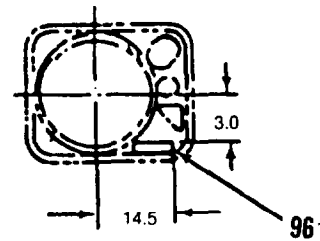
DETAIL A



DETAIL B
(LOOKING OUTBD)



DETAIL C



DETAIL D
(LOOKING OUTBD)

Figure 9-9. Interior Markings, CH-47 (Sheet 7 of 20)

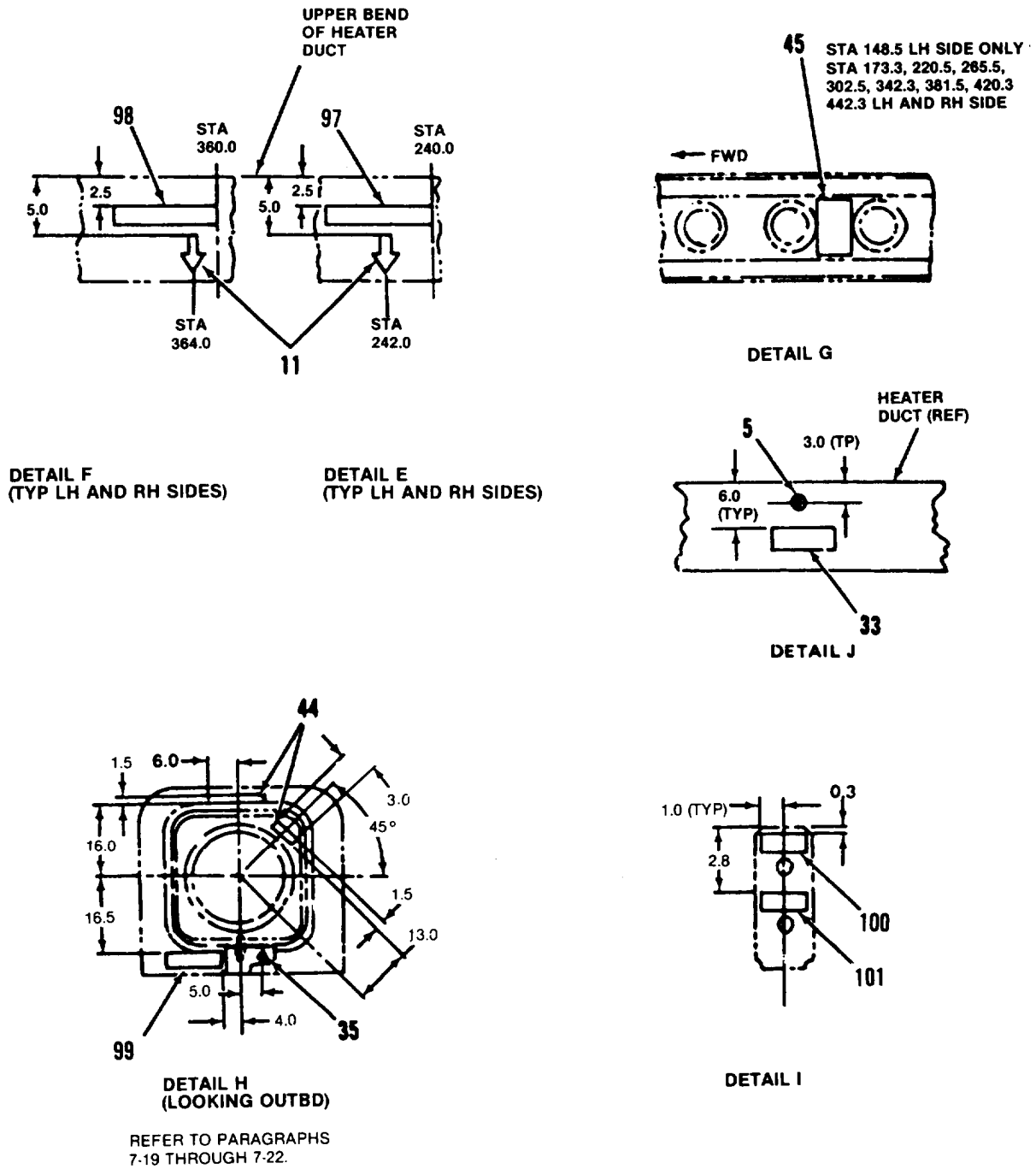


Figure 9-9. Interior Markings, CH-47 (Sheet 8 of 20)


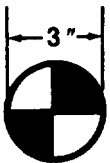

CODE NO.	DIRECTIONS	WORDING
1	Left side of fuselage at station 106.5, WL 32.5.3 in. MIL-C-46168, aircraft white, No. 37875, circle with 1-in. MIL-C-46168, aircraft red, No. 31136, cross.	
2	Left side of fuselage at station 106.5, WL 45.2. 1/2-in. white letters.	NO 2 CONTROL SYSTEM FILTER
3	Right side, sta 157, above door 1/2-in. white letters.	LEVELING BRACKET
4	Both sides, station 163.5, WL 27.6. 1-in. white letters.	MAX CONCENTRATED FLOOR LOADING FWD OF STA 160.0 NOT TO EXCEED 1000 LBS CONCENTRATED LOAD.
5	Both sides of fuselage centered on station 181, 303,425 at WL 35.0. 3 in. MIL-C-46168, aircraft black, No. 37038 and MIL-C-46168, aircraft white, No. 37875. See Detail J for type.	
6	Both sides of fuselage. Station 249 and 348 at WL 8.0 1-in white letters.	UT RECP
7	Both sides of fuselage at station 249 and 348 at WL 6.0 1/2-in white letters.	28VDC AMPS: 1 = 15A 2 = 7.5A 3 = 5A
8	Both sides of fuselage at station 317. WL 44.9. 1/2' white letters.	115V, 3PH, 400CY, 15AMP
8	CH-47D, both sides of fuselage at station 317, WL 44.9, 1/2-in. white letters.	115V, 1PH, 15AMP 115V, 3PH, 15AMP
9	Both sides of fuselage at station 317.0, WL 41.9.1' white letters.	MISSILE HEAT PLUG
9	CH-47D, both sides of fuselage at station 317.0, WL 41.9, 1-in white letters.	400 CYCLE AC UTILITY RECEPTACLE
10	Right side of fuselage at station 335.0, WL 23.9. 1-in. white letters	HOIST OPER STATION
11	Arrow white 1/2-in. X 3 in. See Detail C, E and F.	
12	Right side of fuselage. Station 363.3, WL 37.1. 1-in. white letters.	HOIST OPER ATTACH.
13	Right side of fuselage at station 506, WL 36.0. 1/2-in. white letters.	RAMP MANUAL OVERRIDE

Figure 9-9. Interior Markings, CH-47 (Sheet 9 of 20)

CODE NO.	DIRECTIONS	WORDING
14	See View G-G, and Detail C, station 549.3, WL 53.0: station 538.8 WL 8.5. 1/2" white letters NOTE: 5 req'd on S/N 59-4983 thru 66-19028. 4 req'd on S/N 66-19029 and subsequent.	ACCUMULATOR CHARGE 1400 PSI—AIR OR NITROGEN
15	Station 525, WL 22.5. Right side of fuselage. Finish half of filler cap, orange; the other half MIL-C-46168, aircraft gray interior, No. 36231	FILLER UTILITY TANK
16	Right side of fuselage, station 550, WL 33.5. 1/2" white letters. Eff. on CH-47 S/N 65-7978 and subsequent.	UTILITY RETURN FILTER
17	Right side of fuselage, station 538.8, WL8.5. 1/2" white letters.	INITIAL 1800 PSI CHARGE REQ'D FOR - 65° F OPERATION
18	Right side of fuselage, station 517.5, WL36. 1/2 in. white letters.	UTILITY PRESSURE FILTER
19	Both sides of fuselage. Two places, station 220, 391 and 460. WL -21.5.1" white letters. Arrow is 1" X 3". 3 places on heater dust on each side.	10000 LB TIE DOWN HERE ONLY ↓
20	Both sides of fuselage. Centered on station 425. WL -21.5. 1/2" white letters. Eff on S/N 64-13117 thru 65-7977. S/N 56-7978 and subsequent.	CARGO E STA 425 CAP 15250 LBS. CAP 22875 LBS.
21	Both sides of fuselage, station 160,225 and 438. WL-21.5.1" white letters.	ALL TIE DOWN RINGS 500 LBS UNLESS NOTED
21	CH-47D, Both sides of fuselage, station 160, 225, and 438, WL-21.5, 1" white letters.	ALL TIE DOWN RINGS 5000 LBS UNLESS NOTED
22	Both sides of fuselage. Station 306.8 WL -21.5 White letters. Eff S/N 64-13117 thru 65-7977. S/N 65-7978 and subsequent.	CARGO D STA 303 CAP 15250 LBS. *CAP 22875 LBS.
23	Both sides of fuselage at 14 places at heater outlets. 1st line 1" letters. Remainder 1/2" letters (white).	HEAT AND VENT LOOSEN SCREW TO ADJUST SLIDE OPEN ← → CLOSED
24	Right side of fuselgae on beam. BL 18 beam 1" white letters	TO STOW SEAT-FOLD BACK FWD & SECURE WITH STRAP – FOLD DOWN SEAT

Figure 9-9. Interior Markings, CH-47 (Sheet 10 of 20)

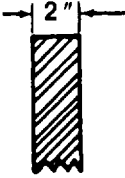
CODE NO.	DIRECTIONS	WORDING
25	Left side of fuselage at station 561. WL 33.4, 1/2" white letters	MIRROR STOWAGE
26	Left side of fuselage station 492. WL 28.4. First line, 1/2" letters. Second line, 1/4" letters, white	FUEL VALVE NO 1 ENGINE ← OPEN CLOSE →
27	Left side of fuselage. Station 198, WL-6.3. 1" white letters.	DO NOT COVER AIR INLET
28	Left side of fuselage. Station 106. WL26.0. 1/4" white letters, mount on 114S1610, BL 8.0 beam. Eff on S/N 59-4983 thru 65-7989	TORQUE MTG BOLTS FOR 114CS101 and 114CS103 TO - 0 40 in. lbs. + 4
	Eff on: S/N 65-7990 and subsequent, except CH-47D	TORQUE MTG BOLTS FOR 114CS101 and 114CS117 TO - 0 40 in. lbs. + 4
29	Left side of fuselage. Station 100.0. WL 45.2. 1/2" white letters. CH-47A, B and C only.	NO 1 SAS FILTER
30	Left side of fuselage, station 94.0, WL 45.2. 1/2" white letters. CH-47A, B and C only.	NO 2 SAS FILTER
31	Left side of fuselage. Station 85.0. WL 50.8. 1/2" white letters.	NO 1 CONTROL SYSTEM FILTER
32	Left side of fuselage. Station 106.0, WL 13.5. 1/2-in. white letters.	PITOT AND STATIC DRAINS
33	See Detail J. Station 184, on heater duct. 1st line, 1" letters, remainder 1/2 letters, white, eff on S/N 64-13117 thru 65-7977	CARGO C STA 181 CAP 15250 LBS
	Eff on S/N 65-7978 and subsequent.	CARGO C STA 181 CAP 22875 LBS
34	1/2 wide black and aircraft white stripes, vertical on station 482 from WL-9.0 to WL-21.5. Eff on S/N 62-2114 and subsequent.	

Figure 9-9. Interior Markings, CH-47 (Sheet 11 of 20)





CODE NO.	DIRECTIONS	WORDING
35	Left side of fuselage centered on station 486 and WL-2.0.1" white letters.	STA 486
36	3 places in fuselage. 1" black letters on orange-yellow background. Station 492, WL -6.5, BL37.0, WL38.7, View B—B.	FIRE EXIT
37	Left side of fuselage, station 537, WL + 3.5. 1/2" white letters. Eff on S/N 59-4982 thru 65-7977 Eff on S/N 65-7978 and subsequent	J-2 COMPASS FLUX VALVE COMPASS FLUX VALVE
38	Left side of fuselage, station 537, WL 22.2. 1st two lines 1/2", last line 1/4" white.	EMERGENCY APU FLUID SHUTOFF VALVE CLOSED  OPEN 
39	Left side of fuselage, station 334.0, WL-12.0. 1" white letters.	CRANK STOWAGE – RESCUE HATCH & RAMP MECH.
40	Centered on door, 1/2" white letters	ACCESS- PITOT AND STATIC DRAIN LINES
41	On floor, station 340 approx. Arrow 1/2" X 3.50 aircraft white on black, see View S-S.	
42	Right side, sta 526, 1/2" white letters.	FILLING
43	Right side, sta 526, 1/2" white letters.	NORMAL
44	Centered on rear door, first line 1", remainder 1/2" orange-yellow, refer to View U—U and Detail H.	EMERGENCY EXIT PULL STRAP OUT – PUSH PANEL
45	Fig 8, Detail G, 1" white letters L.H. and R.H. side, station 173.3, 220.5, 265.5, 302.5, 342.3, 381.5, 420.3, and 442.3.	W.L. O
46	On lower door, station 345, 1" aircraft white letters.	TURN LATCH TO UNLOCK & LOCK OUTER HATCH-CAUTION-UNLOCK BEFORE TURNING CRANK TO OPEN HATCH
47	On lower door, station 322.1" aircraft white letters and arrow.	UNLOCK 

Figure 9–9. Interior Markings, CH-47 (Sheet 12 of 20)

CODE NO.	DIRECTIONS	WORDING
48	View A—A, looking up, station 143 BL 11.0. 1/2" white letters.	STATIC LINE DRAIN
49	View A—A and D—D (looking up), station 152 and 442. 1/2" white letters.	CRANE ACCESS
50	View B—B, 1" white letters, sta 120.0, BL 38, WL 40.5, BL 28 WL 43.0.	STA 120.0
51	View B—B, 1/4" white letters, BL 25, WL 49.0.	TROOP WARNING SYSTEM
52	View B—B, 1/2" white letters, BL 15.5, WL 48.0.	RESCUE PULLEY ATTACH
53	View B—B 1" white letters station 120, BL 17. WL 3.9	LITTER POLE STORAGE
54	View B—B. 1" white letters sta 120, BL 12.0 WL 45.0. Eff on quantity of 1 ea S/N 65-7966-65-7977, Quantity of 2 ea, S/N 65-7978 and sub. Also station 594 (see View G—G).	ANCHOR LINE ATTACH.
55	View B—B, 1/4" white letters, station 95. BL 29.0, WL 15.5	CABIN LIGHT RELAYS RED WHITE
56	View B—B, 1" white letters Sta 120, BL 17.2, WL-20.	WINCH CABLE STOWAGE
57	View C—C (looking up). Center of helicopter, station 320 and 338. 1/4" white letters.	RESCUE CABLE CUTTER PULLEY ATTACH
58	View C—C (looking up), BL 8.4, station 337.0. 1/2" white letters.	CABLE CUTTER PLUG
59	View D—D (looking up), 1/2" white letters, 4 places.	ACCESS MIX BOX MOUNTING BOLTS
60	View E—E, 1" white letters, 4 places.	STA 482.0
61	View F—F (looking up), 1/2" white top center of fuselage, fwd of sta 534 on door.	ACCESS-SYNCH SHAFT THOMAS CPLG.
62	View G—G (looking up). 1/2" white letters. 2 places.	ACCESS XMSN UNLATCH DROP PANEL
63	View G—G (looking up). 1/2" white letters.	ACCESS - MAG PLUG

Figure 9–9. Interior Markings, CH-47 (Sheet 13 of 20)





CODE NO.	DIRECTIONS	WORDING
64	View G—G(looking up). 1" white letters, 2 places to be read from either side.	NO HANDHOLD
65	View G—G (looking up). 1/2" white letters, 2 places.	XMSN OIL LEVEL SIGHT GAGE VIEW PLATE
66	View H—H, 1/2" black letters.	SEQUENCE VALVE
67	View J—J, 1" white letters, station 594.0, left and right side.	STA 594.0
68	View J—J, 1" orange-yellow letters.	 DANGER HIGH VOLTAGE 
69	View K—K, 1" white letters, 4 places.	STA 575.0
70	View L—L, 1" white letters, 4 places.	STA 554.0
71	View M—M. 1" white letters. 4 places.	STA 534.0
72	View N—N, 1" white letters, 4 places.	STA 502.4
73	View N—N, 1/2" white letters.	HOIST CONTROL 
74	View P—P, 1" white letters, 4 places.	STA 200.0
75	View P—P, 1" white letters, 4 places.	STA 240.0
76	View P—P, 1" white letters, 4 places.	STA 280.0
77	View P—P, 1" white letters, 4 places.	STA 320.1
78	View P—P, 1" white letters, 4 places.	STA 360.0
79	View P—P, 1" white letters, 4 places.	STA 400.0
80	View P—P, 1" white letters, 4 places.	STA 440.0
81	View P—P, 1" white letters, 3 places.	STA 160.0
82	View Q—Q, 1" white letter stencil to be readable from centerline A/C with door closed. Mount to under surface of step,	PUSH TRIGGER TURN HANDLE UP PUSH DOOR OUT 
83	View R—R, 1" black letters. Center hook.	CARGO HOOK CAP 16000LB. (C H-47A) CARGO HOOK CAP 20000 LB. (CH-47B/C) CARGO HOOK CAP 28000 LB. (CH-47D)

Figure 9-9. Interior Markings, CH-47 (Sheet 14 of 20)

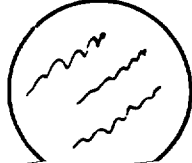

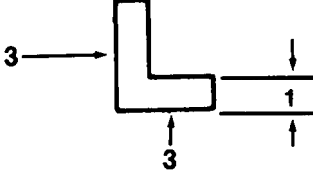
CODE NO.	DIRECTIONS	WORDING
84	1 in. black letters.	CARGO HOOK CAP 20000 LB (CH.47D)
85	View S—S, 1" black letters.	HOOK STOWAGE STRAP
86	View T—T (ref Fig 3). 1/2" white letters. (Stencil to be readable when rotated into work platform position).	MAX. WEIGHT 200 LBS ON WORK PLATFORM
87	View V—V, first line, 1/2" white, second line, 1/4" white, station 502.4	FUEL VALVE CROSS FEED ← CLOSE OPEN →
88	Detail A, first line 1" orange-yellow, second line 1/2 orange-yellow with arrow, 1/2" x 2-1/2" on black handles in cockpit. See arrow position in Detail A. For information on marking pilot and co-pilot doors, see paragraph 7-24.	EMERGENCY EXIT → TURN HANDLE
89	Detail B, 1" orange-yellow letters, left side between station 280 and 320. Right side between station 360 and 400 place stencil on sides of window as shown. Refer to paragraph 7-22. NOTE: Items 89 and 90 Eff on S/N 59-4983 thru 66-097.	CUT HERE  FOR 
90	Detail B, cut out corners, 1" X 3" aircraft white as shown in item 89.	
91	Detail C, Station 493, WL 28.4, first line 1/2" second line 1/4" white letters.	FUEL VALVE NO. 2 ENGINE ← CLOSE OPEN →
92	Detail C, Station 505, WL 19.6, first line 1/2" second line 1/4" white letters.	DEFUEL VALVE CLOSE ↙ OPEN ↗
93	Two places aft of station 95, 1" white letters. Stencil to be readable from centerline of acft.	ACCESS PANELS – HYDRAULIC LINES, TRANSFORMERS

Figure 9-9. Interior Markings, CH-47 (Sheet 15 of 20)



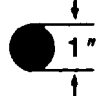
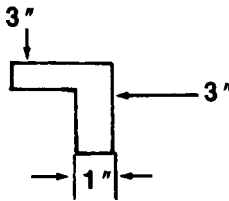
CODE NO.	DIRECTIONS	WORDING
94	Detail C, 1/2" black letters, station 491. Top line on one stringer bottom line on lower stringer at WL 0.	<p>UP STOP DN</p> <p>RAMP CONTROL</p>
95	Detail C, 1" black, station 486, WL-2.0. Arrow 1/2" X 3".	<p>STA. 486.0</p> 
96	Detail D, 1/2" orange-yellow letters. Refer to paragraph 7-22.	<p>EMERGENCY EXIT PULL STRAP OUT PUSH PANEL</p>
97	Detail E, 1" white letters with arrow. Arrow located on Station 242.	<p>STA. 242.0</p> 
98	Detail F, 1" white letters. Arrow located on station 364.	<p>STA. 364.0</p>
99	Detail H, 1" white letters. Right side at fwd door.	<p>TURN HANDLE UP LIFT DOOR</p>
100	Detail I, View B—B, aft side, station 95.0, 1/4" white letters.	<p>CABLE CUTTER</p>
101	Detail I, and View B—B, aft side, station 95.0, 1/4" white letters.	<p>HOIST CONTROL</p>
102	View M—M, 1/2" white fwd side, station 534.	<p>HYDRAULIC RES. GAGE</p>
103	Aircraft white letters, 1/2", station 440, BL 26 and station 165.	<p>LOCATION FOR MAINT CRANE BASE PLATE</p>
104	Aircraft white dot, 1" station 138.5, 166.5, 427 and 455, BL 26.	
105	Black corner markings, 1" X 3" station 133.86, 174.36, 424.25 and 464.75 BL 34.44 and BL 19.94, 8 places.	

Figure 9-9. Interior Markings, CH-47 (Sheet 16 of 20)

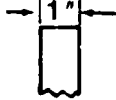





CODE NO.	DIRECTIONS	WORDING
106	Orange-yellow letters, 1" station 348, center of A/C floor. To be read facing fwd of acft on upper door.	ALTERNATE GROUND EMERGENCY ESCAPE LIFT
107	Stripe 1" wide across cabin floor at station 120, 242, 364, and 486. Stripe to be aircraft white	
108	Center floor on ramp, 1" white letters.	MAX WEIGHT 200 LBS. ON WORK PLATFORM
109	White 1/2" letters, station 500 on floor.	LIFT PLUG FOR MANUAL CARGO DOOR CRANKING  OPEN
110	Aircraft white 1" letters, fwd edge of stencil on station 360, OB edge of stencil on BL 17.25.	 CRANK HERE TO OPEN AND CLOSE OUTER HATCH  OPEN
111	White 1/2" letter, station 132.5, BL 24.5, top of letters facing outboard.	RESCUE PULLEY ATTACH 
112	Non-skid material on floor. Material required is MIL-W-5044. Type II aft of sta 120 and Type I fwd of sta 120. Refer to paragraph 3—11.	
113	At rear emer. exit, 1" black letters on 15" Orange-yellow arrow. Pointing toward handle. Eff on S/N 66-, 118 and subsequent. Refer to paragraph 7-22.	
114	Right side station 516, WL 53. 1/2" white letters. Eff on S/N 65-7978 and subsequent.	BRAKE RETURN LINE FILTER
115	White 1/2" letters, station 525, WL 53 and station 554, WL 29.5, eff on: Qty of 1- S/N 65-7978 thru 65-7994, Qty of 2-S/N 65-7995 & sub.	WARNING FILTER MAINTENANCE REQUIRED WHEN RED INDICATOR IS EXTENDED.

Figure 9-9. Interior Markings, CH-47 (Sheet 17 of 20)


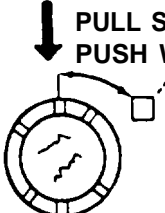



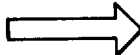
CODE NO.	DIRECTIONS	WORDING
116	White 1/2" letters, station 95, WL 21 above 114S1655 back-up panel. Eff on S/N 65-7990 & sub.	WARNING INSTALL BACK-UP PANEL BEFORE FLIGHT
117	First line, 1/2", lower line 1/8" white, location, station 116, WL 12.0, adjacent to flow regulator. L. S., eff on S/N 65-1995 & sub.	<p style="text-align: center;">FLOW REGULATORS</p> <p style="text-align: center;">  </p> <p style="text-align: center;">REGULATED FLOW DIRECTION</p>
118	Typical for 8 windows. Both sides at station 220, 300, 380, 460, first line 1" letters, remainder 1/2" orange-yellow or reflective letters. 1/2" x 1" orange-yellow stripe around window at 6 places (positions 12, 2, 4, 6, 8, and 10 o'clock). Eff on S/N 66-098 and subsequent. Refer to paragraphs 7-19 thru 7-22.	<p style="text-align: center;">EMERGENCY EXIT PULL STRAP OUT PUSH WINDOW OUT</p> <p style="text-align: center;">  </p>
119	View N-N, both sides at station 502.33, WL 19.0, black letters 1/8" (metal-cal) eff on S/N 66-19059 and subsequent.	FUEL VALVE WARNING LIGHT
120	View B-B, 5" white letters, station 120 center of mounting holes. Eff on S/N 65-8014 and subsequent. S/N 66-118 and subsequent	<p style="text-align: center;">XM 24 GUN MTG</p> <p style="text-align: center;">  </p>
121	A two (2") wide lusterless aircraft white stripe across the floor. Centered on station 160.	<p style="text-align: center;">  </p>
122	Above the fire axe on right side on the upholstery at station 200, black 1" letters on an aircraft white rectangle.	FIRE AXE
123	CH-47D, 3/8" white letters, station 522.5, WL +35.5	APU CONTROL BOX
124	CH-47D, Left side of fuselage, 1/2" white letters, station 553.5, WL+8.0	<p>INTERPHONE WALKING CORD STOWAGE </p>
125	CH-47D, left side of fuselage, 1/2" white arrow, station 492, WL+16.0	

Figure 9-9. Interior Markings, CH-47 (Sheet 18 of 20)


CODE NO.	DIRECTIONS	WORDING
126	CH-47D, 1" white letters, 8 required	ALL TIEDOWN RINGS 5000 LB UNLESS NOTED
127	CH-47D left side of fuselage, 1/2" white letters, station 206.0, WL+40	N1 CONT ENG 1
128	CH-47D right side of fuselage, 1/2" white letters, station 206.0, WL+40	N1 CONT ENG 2
129	CH-47D right side of fuselage, 1/2" white letters, station 585.0, WL+48.5	APU START MDL
130	CH-47D right side of fuselage, 1/2" white letters, station 560.0, WL+30.5	NORMAL —┐ └ OPEN
131	CH-47D right side of fuselage, 1/4" white letters and arrow, station 538.0, WL+41.5	 At temps above 25° F precharge accumulator to 1800 psi with air or nitrogen. Accumulation will bottom at 3000 psi.
132	CH-47D right side of fuselage, 1/4" white letters, station 538.0, WL+38.0	At temps below minus 25° F precharge accumulator 2050 psi with air or nitrogen. Accumulator will bottom at 3350 psi.
133	CH-47D right side of fuselage, white letters, station 538.0, WL+34.5	<p style="text-align: center;">CAUTION $\frac{1}{2}$"</p> <p style="text-align: center;">DO NOT HAND PUMP SYSTEM $\frac{1}{4}$"</p> <p style="text-align: center;">ABOVE BOTTOMING PRESSURES. $\frac{1}{4}$"</p>
134	CH-47D right side of fuselage, white letters, and 1/2" arrow, station 515.5, WL+16.0	<p>EMERGENCY $\frac{1}{2}$"</p> <p>UTIL PRESS $\frac{1}{2}$"</p> <p>← EMER. NORM → $\frac{3}{8}$"</p>
135	CH-47D right side of fuselage, 1/2" white letters, station 515.5, WL+14.5	<p style="text-align: center;">EMERG UTIL PRESS</p> <p style="text-align: center;">NORMAL —┐ └ OPEN</p>
136	CH-47D right side of fuselage, 3/8" white letters, station 517.0, WL+7.5	<p style="text-align: center;">HYDR SYS FILL</p> <p style="text-align: center;"> NO. 1 FLT SYS — C—NO.2 FLT SYS 3 L—UTILITY OFF —┐ └ 2 1 </p>

Figure 9-9. Interior Markings, CH-47 (Sheet 19 of 20)


CODE NO.	DIRECTIONS	WORDING
137	CH-47D, right side of fuselage, 1/2" white letters, station 523.0, WL+7.5	HYDR SYS FILL . . .
138	CH-47D, center of floor, 3/8" white letters and arrow, station 330.0	EMERGENCY RELEASE CENTER HOOK 

Figure 9-9. interior Markings, CH-47 (Sheet 20 of 20)

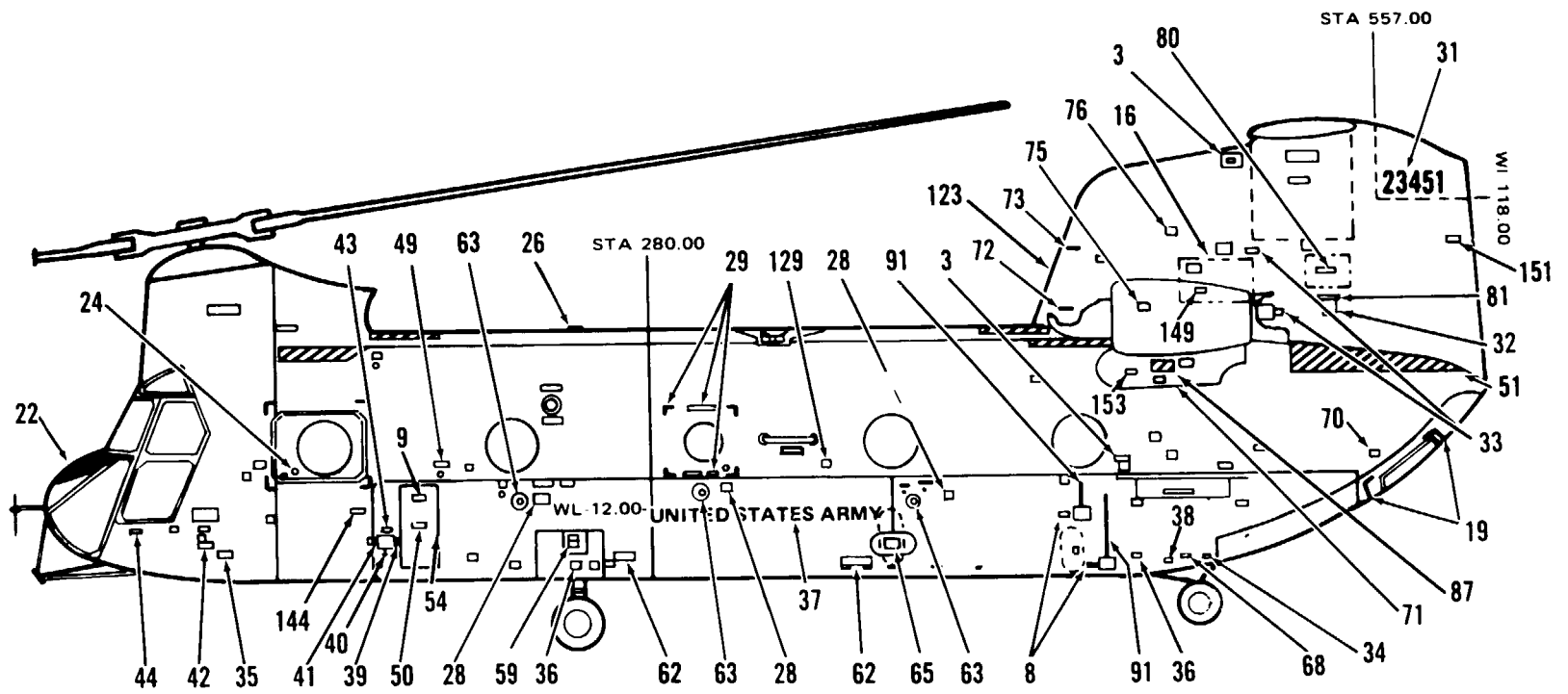
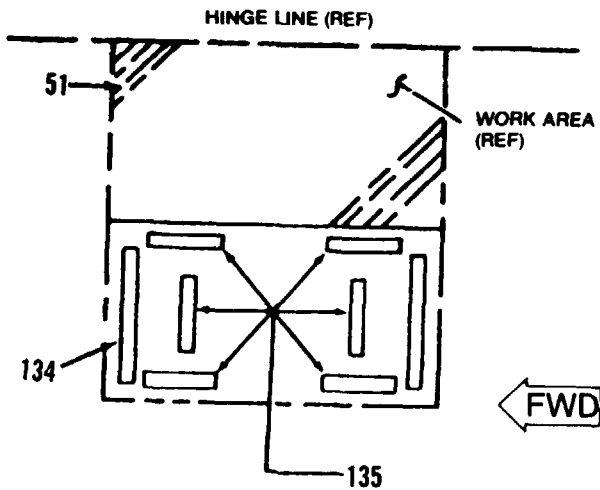


Figure 9-10. Exterior Markings, CH-47 (Sheet 1 of 29)



AFT PYLON WORK PLATFORM
(VIEW LOOKING DOWN. LEFT
SIDE SHOWN, RIGHT SIDE OPPOSITE)

SEE
DETAIL B

LEFT SIDE VIEW

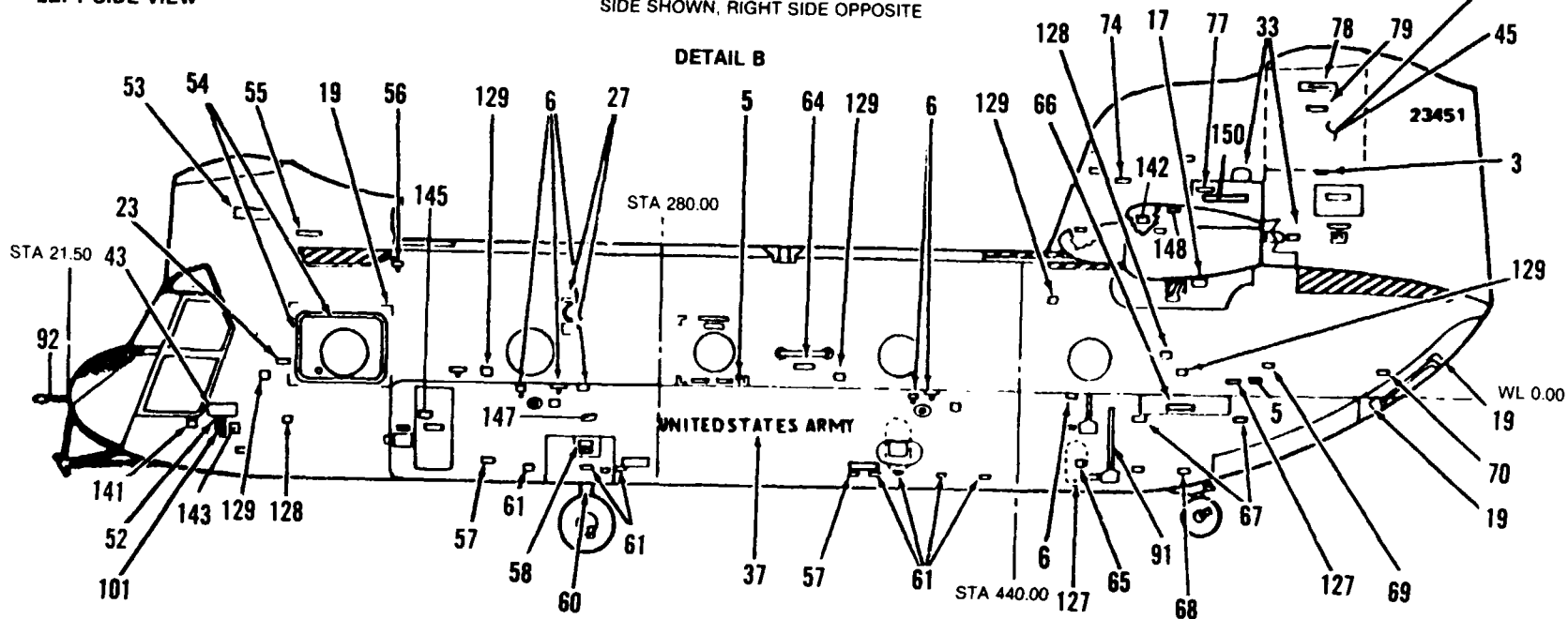


Figure 9-10. Exterior Markings, CH-47 (Sheet 2 of 29)

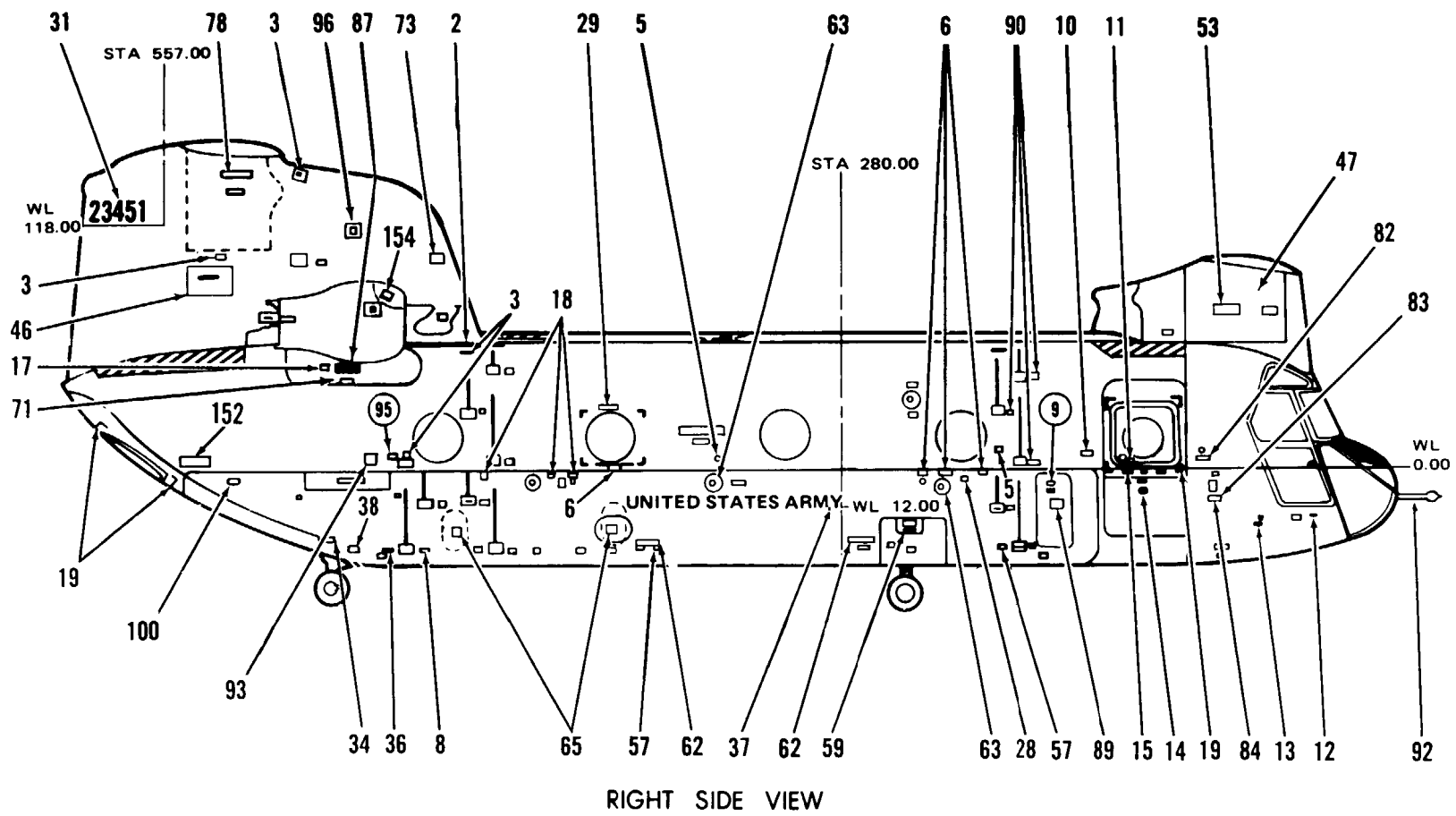


Figure 9-10. Exterior Markings, CH-47 (Sheet 3 of 29)

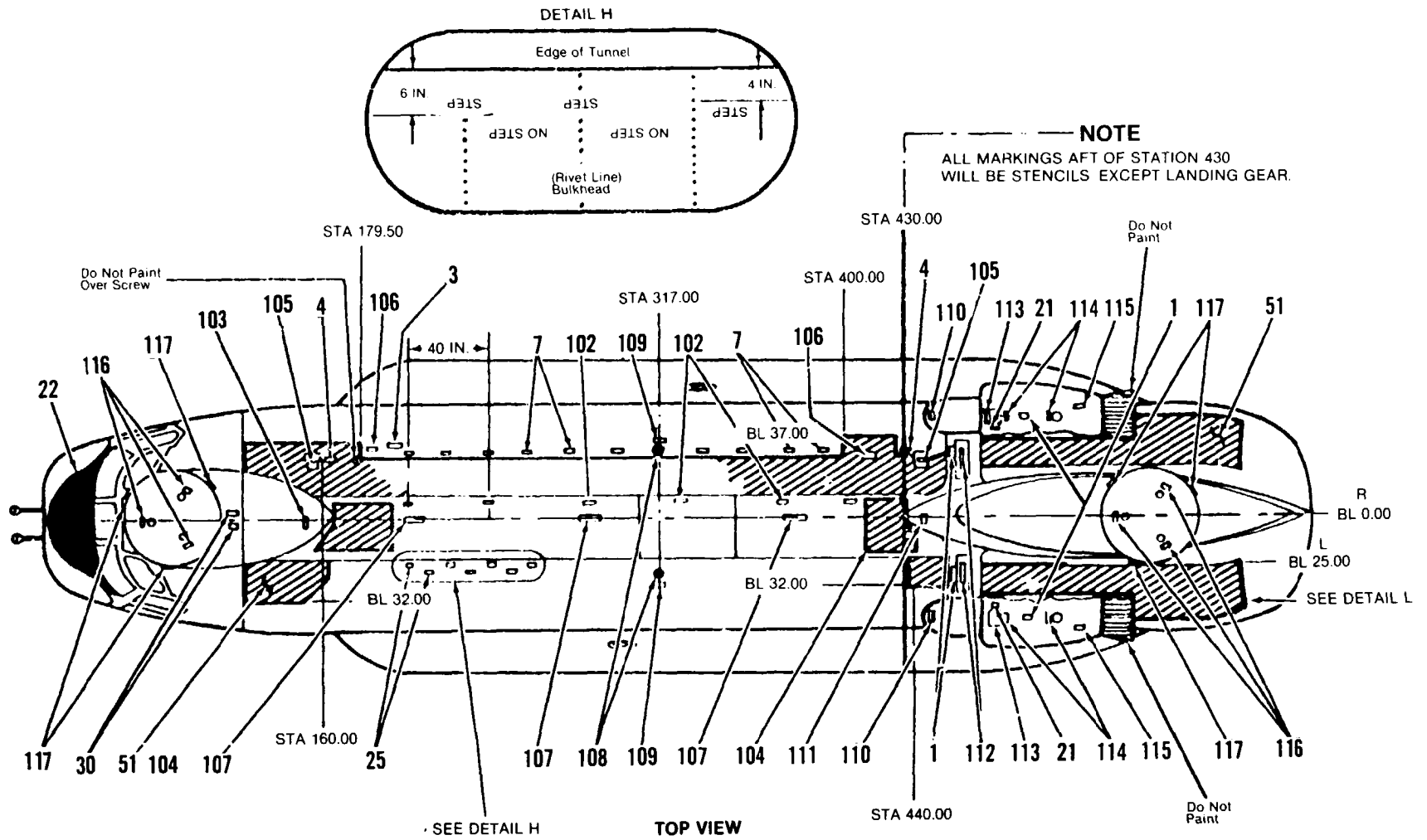
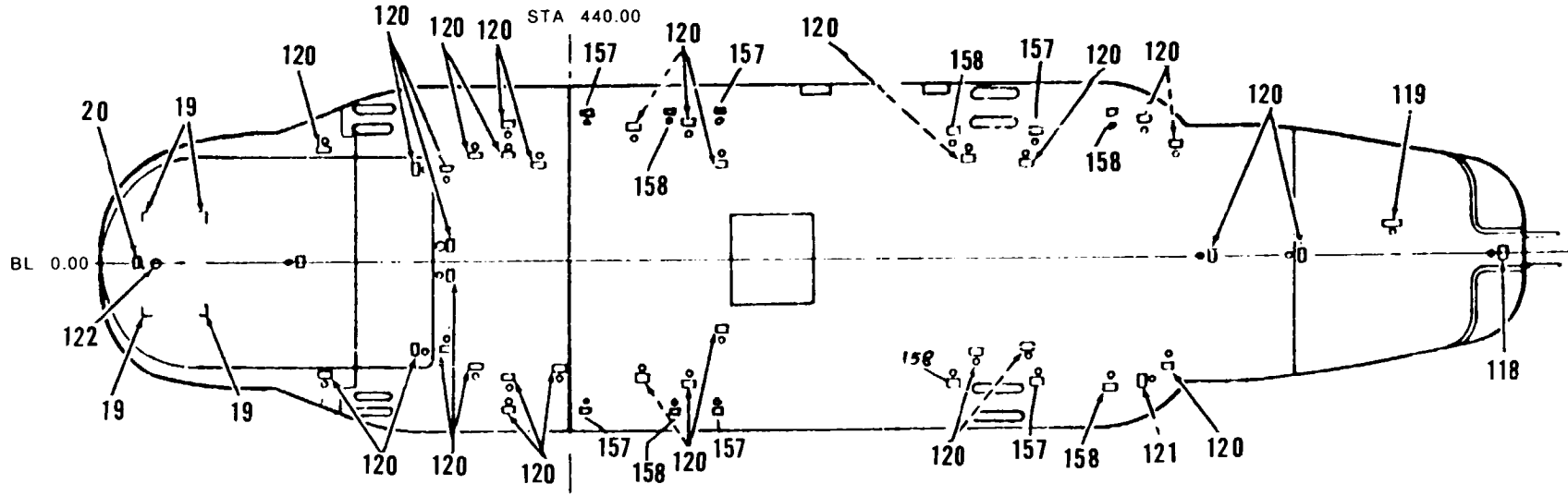


Figure 9-10. Exterior Markings, CH-47 (Sheet 5 of 29)

NOTE: ON HELICOPTER WITH MULTIFUEL CELLS



STENCILS ONLY
AFT OF STA 430.0

BOTTOM VIEW

Figure 9-10. Exterior Markings, CH-47 (Sheet 6 of 29)

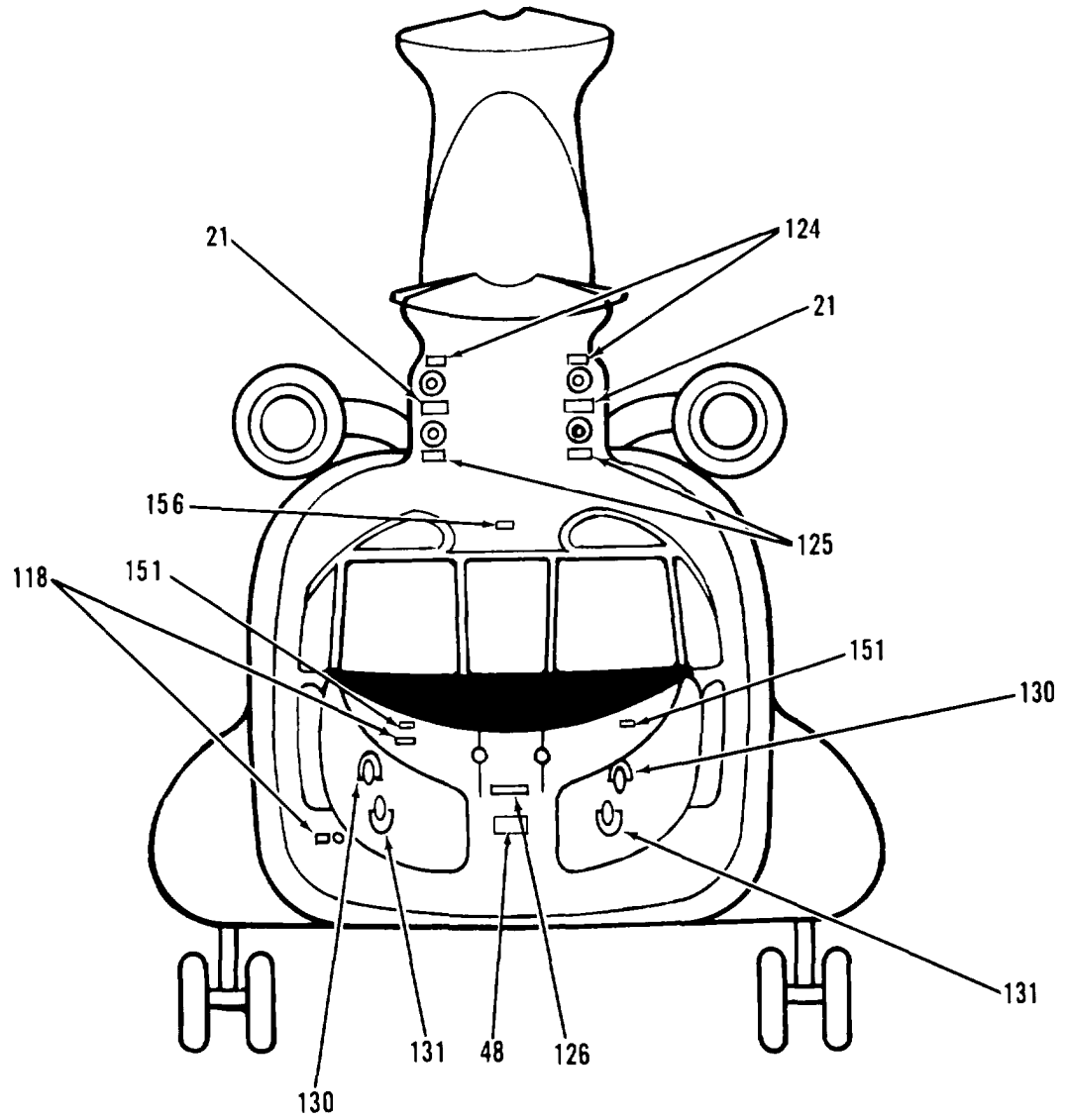
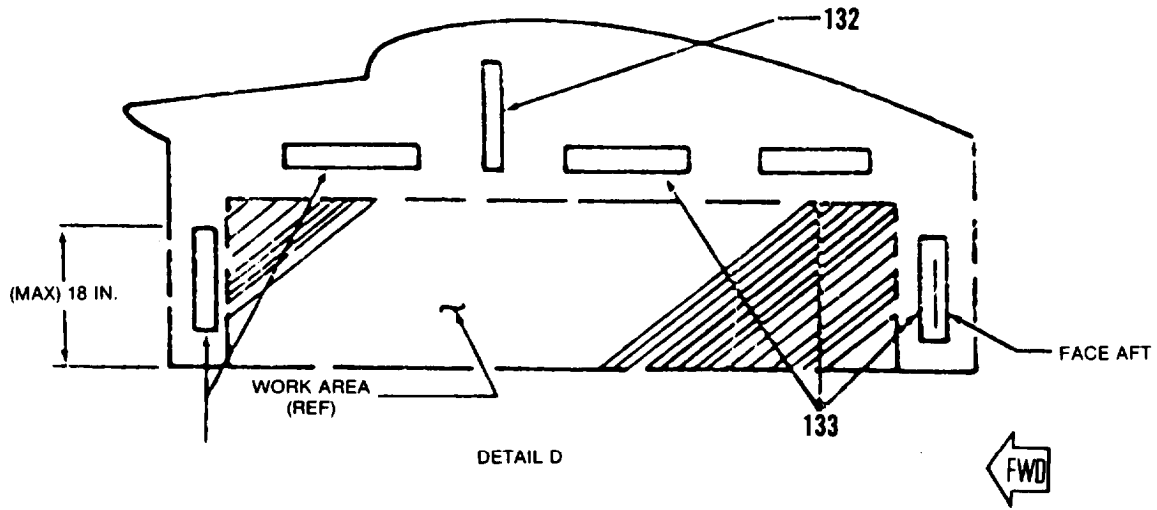
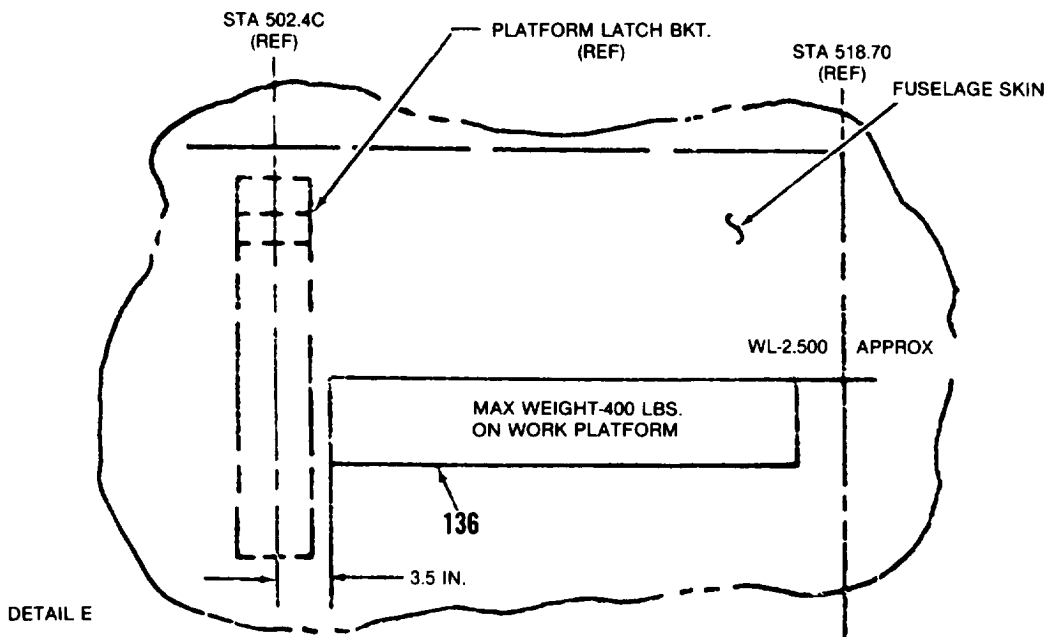


Figure 9-10. Exterior Markings, CH-47 (Sheet 7 of 29)

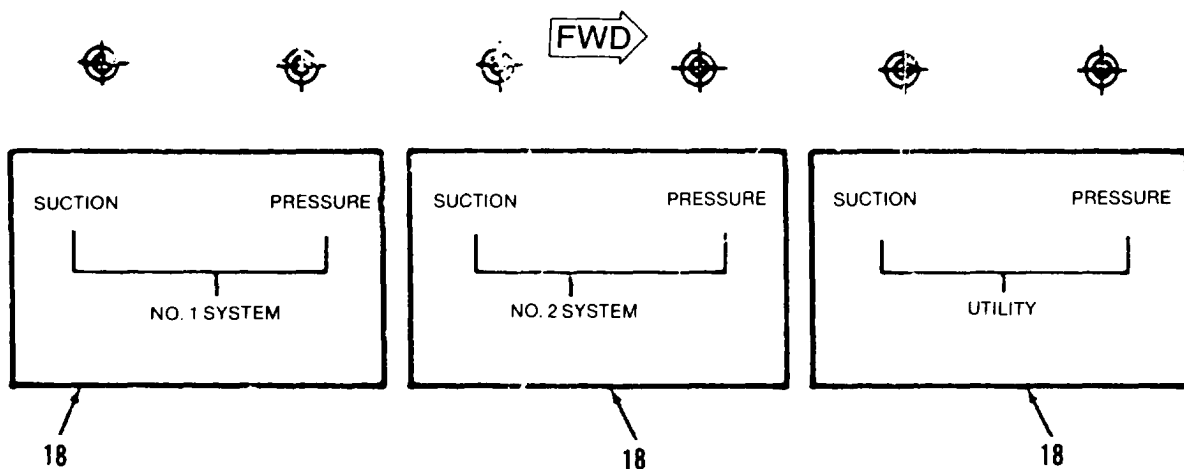


FORWARD PYLON WORK PLATFORM
(VIEW LOOKING DOWN. RIGHT
SIDE SHOWN, LEFT SIDE
OPPOSITE)

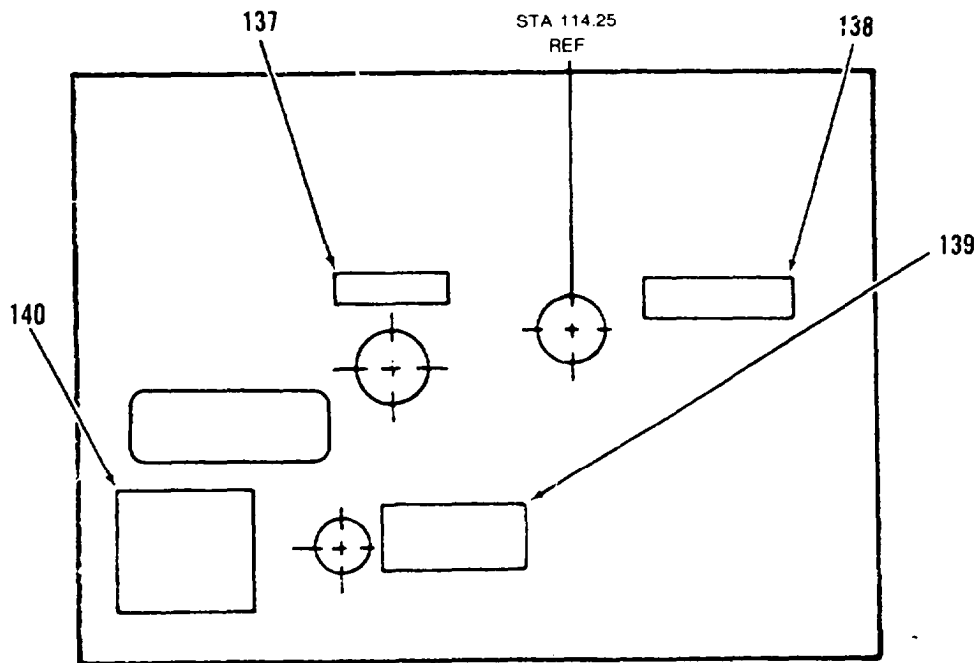


ENGINE WORK PLATFORM
(VIEW LOOKING INBD
WITH PLATFORM IN OPEN
POSITION. RIGHT SIDE
SHOWN. LEFT SIDE OPPOSITE)

Figure 9-10. Exterior Markings, CH- 47 (Sheet 8 of 29)



VIEW LOOKING AT HYDRAULIC TEST PANEL
DETAIL F



DETAIL G
RECEPTABLE PANEL

Figure 9-10. Exterior Markings, CH-47 (Sheet 9 of 29)

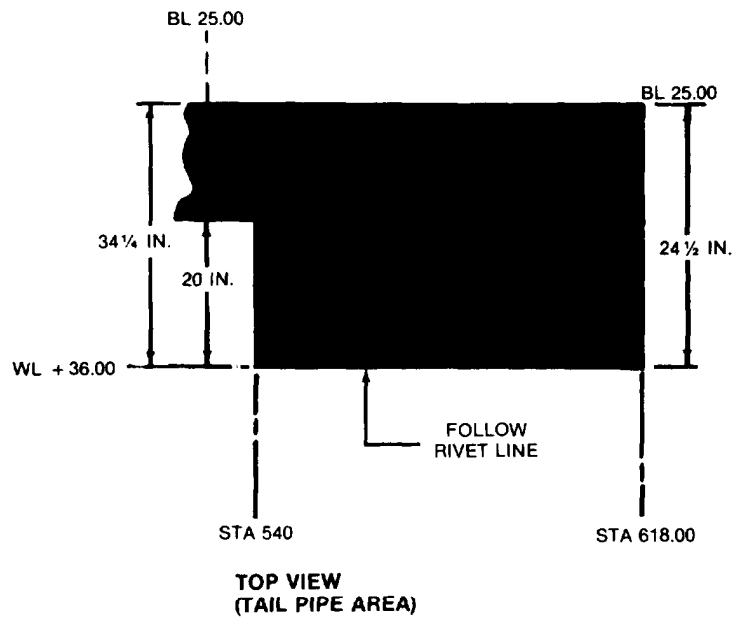
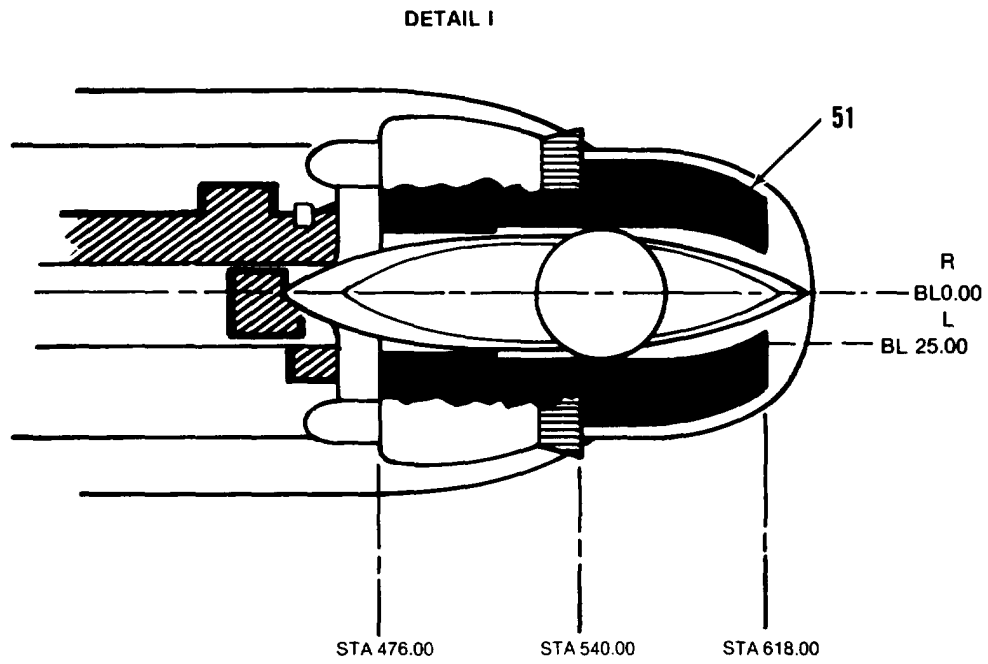


Figure 9-10. Exterior Markings, CH-47 (Sheet 10 of 29)

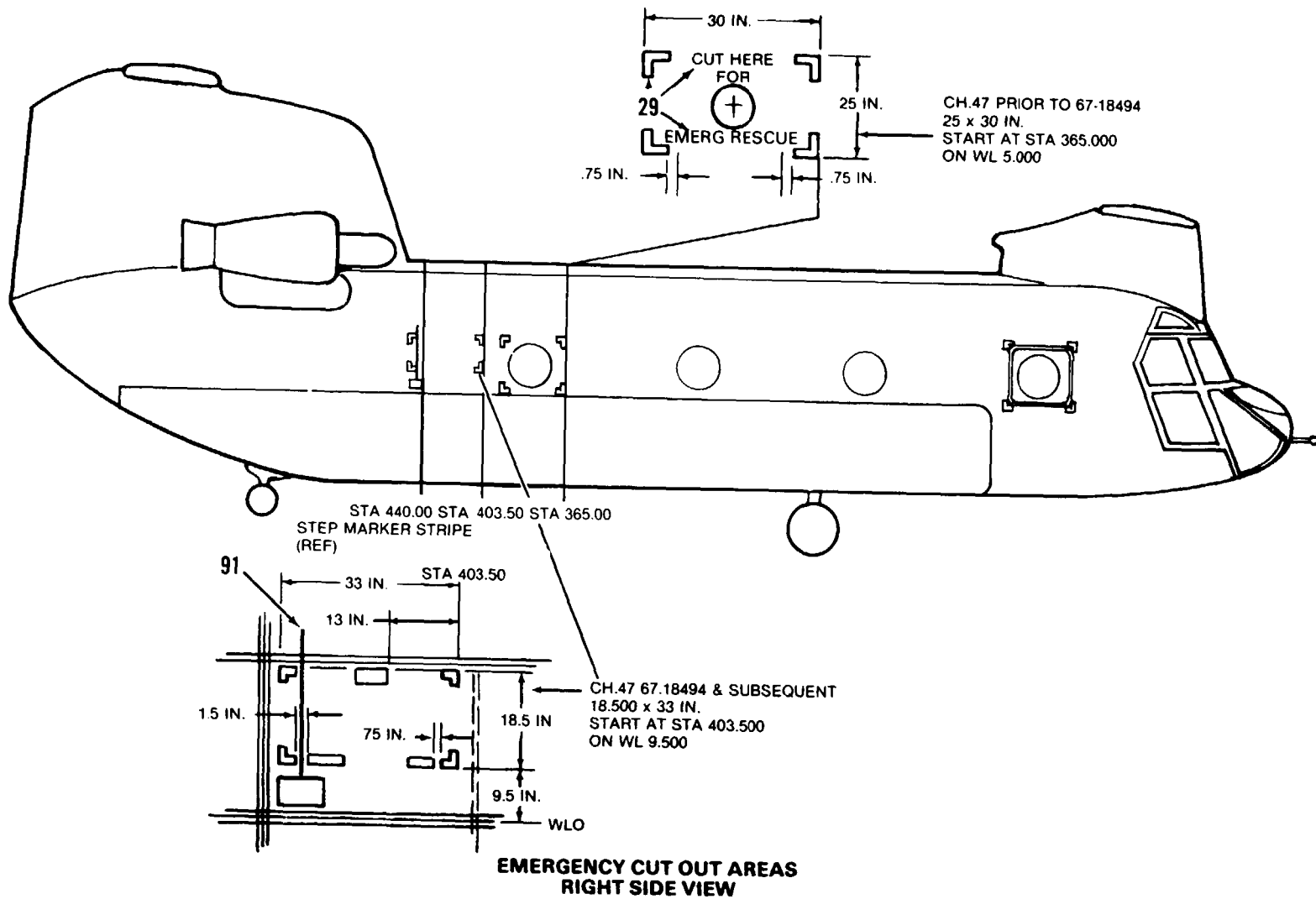


Figure 9-10. Exterior Markings, CH- 47 (Sheet 11 of 29)

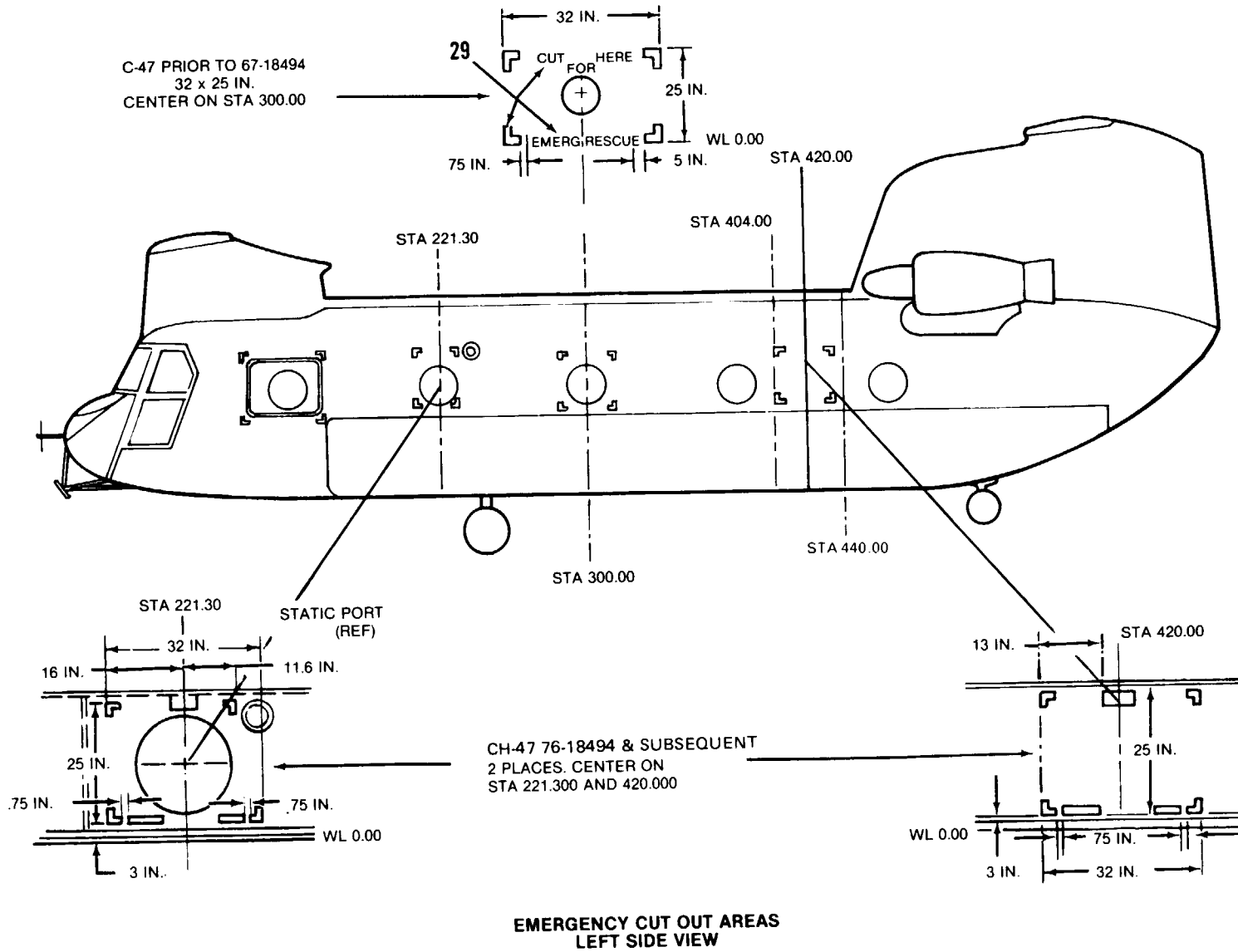
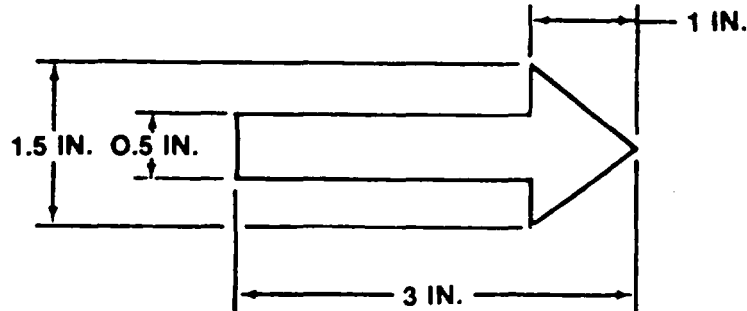


Figure 9-10. Exterior Markings, CH-47 (Sheet 12 of 29)

Notes

1. Unless otherwise noted, all lettering is to be 1-in.
2. A standard size arrow will be used, when required, in the following stencil




CODE NO.	DIRECTIONS	WORDING
1.	Fixed portion of cowl between nacelle and vertical fin. Bottom of letters facing fwd. On nonstructural area of fwd rotor housing, right side. To be read while standing on work platform (inside only). Also top of engine nacelle facing outbd MIL-C-46168 aircraft black No. 37038	NO STEP
2	DELETE	
3	Used with each set of steps, both sides of fuse lage. Also, above handgrip, top and side of rear pylon, both sides, aircraft black.	HAND HOLD
4	Adjacent to access doors. To be read from walkway, aircraft black.	INSTALL COVER BEFORE FLIGHT
5	Paint a black ground symbol, shade 37038, dimensions per MIL-C-83413/9-2.	

Figure 9-10. Exterior Markings, CH-47 (Sheet 13 of 29)






CODE NO.	DIRECTIONS	WORDING
6	Both sides of fuselage, 1/2.in. aircraft black letters. NOTE: CH-47, serial No.68-15812 and subsequent, sta 330. CH-47, serial No. 6718494 thru 68-15811, sta 245 and 386. CH-47, serial No. 66-19098 thru 67-18493, sta 231 and 395. CH-47, serial No. 67-18594 and subsequent, sta 189, 243, 387, and 442. CH-47D, both sides of fuselage, sta 242, 378, 443, WL+.5.	FUEL VENT
7	Right side top of fuselage, 2 in. below walkway, positioned between bulkheads (rivet line) between sta 179.5 and sta 400.1-in. aircraft black letters to be read from walkway.	NO STEP
8	Both sides of fuselage adjacent to step NOTE On CH-47B, serial No. 66-19098, the lower right side of the fuselage has a hinge type folding step. This stencil is applied on the door under the release knob. First line is 1-in., remainder is 1/2-in. aircraft black.	*STEP STEP PULL KNOB DOWN AND OUT TO OPEN STEP
9	On generator control, engine control access door, both sides of fuselage (inside compartment) MIL-C-46168, orange-yellow, No. 33538 letters, sta 176, WL-10.	DANGER HIGH VOLTAGE
10	Aft of fwd entrance door on right side, sta 162, WL 8, in lusterless black letters.	EXIT RELEASE 
11	On emergency exit panel in fwd entrance door on right side fwd of pull tab, aircraft black.	PULL TAB OUT PUSH PANEL IN
12	Below lower flight compartment side window in line with door jettison handle on right side, aircraft black.	 DOOR JETTISON
13	Below door jettison handle on right side of fuselage, sta 93, WL-24, lusterless black letters.	 DOOR JETTISON PUSH TRIGGER TURN HANDLE UP
14	Lower section of fwd entrance door on right side aft of door handle in lusterless black letters, sta 133, WL-12.	 PUSH TRIGGER TURN HANDLE UP PULL DOOR OUT
15	Upper section of fwd entrance door on right side, aft of door release, in lusterless black letters, sta 157, WL-2.5.	 PUSH TRIGGER TURN HANDLE UP

Figure 9-10. Exterior Markings, CH-47 (Sheet 14 of 29)

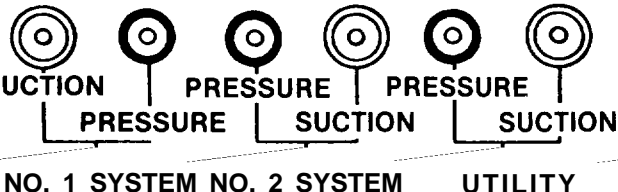
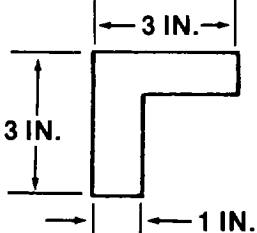

CODE NO.	DIRECTIONS	WORDING
16	1/2-in. aircraft black letters inside pylon.	REMOVE BONDING JUMPER WHEN DOOR IS TO BE REMOVED. INSTALL BONDING JUMPER WHEN INSTALLING DOOR.
17	Below engine nacelles, both sides, aft of air intake screen, sta 503, WL 52, aircraft black. CH-47D, sta 491, WL 52.	ENGINE ACCESS FOR FIRE EXTINGUISHER
18	Hydraulic test panel, tail of fuselage, right side. 1/4-in. aircraft black letters, CH-47A, B, C only	<p style="text-align: center;">HYD SYSTEM TEST PANEL</p>  <p style="text-align: center;">NO. 1 SYSTEM NO. 2 SYSTEM UTILITY</p>
19	Around emergency exit panels. On both sides of fuselage and on rear cargo door, Emer. exit outlines at each corner with corner bands 1 in. wide and 3 in. long at each leg and painted aircraft black.	
20	Centered under cargo ramp, above emergency exit, sta 610, aircraft black.	EMERGENCY EXIT PULL STRAP OUT PUSH PANEL
21	Top center of engine nacelles between oil filler access and oil quantity indicator access doors. Top of letters facing outbd, 1/2-in. aircraft black letters.	LUB OIL MIL-L-23699 ABOVE -25°F MIL-L-7808 BELOW -25°F
22	Antiglare area fwd of windshield, furthest curve is 30-in. fwd of windshield. Paint area lusterless black	
23	Adjacent to fwd edge of fwd emergency exit. left side, sta 119, WL 6. Arrow should point to pull tab. Aircraft black.	EXIT RELEASE 
24	Left side, on bottom corner of emergency exit above pull tab. Aircraft black.	PULL TAB OUT PUSH PANEL IN

Figure 9-10. Exterior Markings, CH-47 (Sheet 15 of 29)

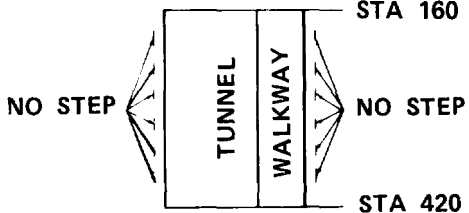
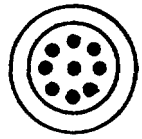
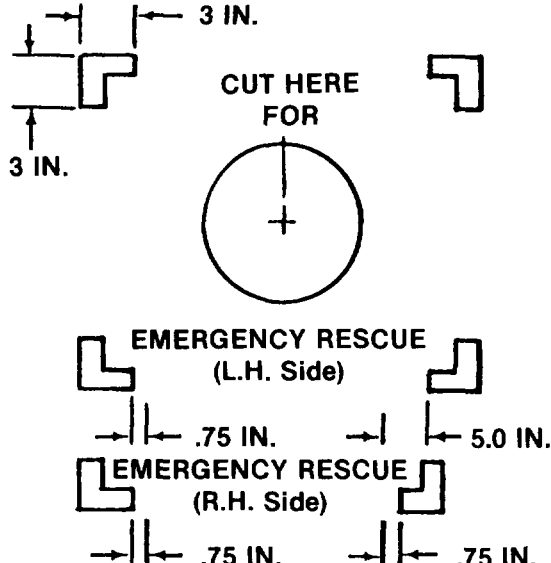
CODE NO.	DIRECTIONS	WORDING
25	Top of fuselage, right side of walk way from Sta 160 to Sta 420, 1-in. aircraft black letters 37038, top of letters facing outboard, Word NO STEP 2" out from walk way, 6 places. On left side of tunnel, word NO STEP 4" out from tunnel on bulk head 6 places.	
26	On top centerline to be read from walkway. CH-47A only, aircraft black.	<p>CAUTION-DISCONNECT ELECTRICAL WIRING BEFORE REMOVING ANTENNA HOUSING</p>
27	Both sides of fuselage at static ports. 1 3/4-in. unpainted area within rivet pattern, 1/2-in. black circle around static port, 6-in. I.D. 1/2-in. letters. Remainder of stencil 1/4-in. letters.	<p>STATIC PORT</p>  <p>DO NOT PLUG OR DEFORM HOLES; AREA WITHIN CIRCLE MUST BE SMOOTH AND CLEAN.</p>
28	Both sides of fuselage. Aft side of filler cap on left side and fwd side of filler cap on right side. The early model helicopters have one tank on each side of the center of the fuselage. Later helicopters have three tanks, one fwd and one aft of the center tank. Aircraft black. Also on CH-47D, right side of fuselage, sta 257., WL-17.	<p>FUEL SERVICE THIS AIRCRAFT WITH MIL-T-5624 GRADE NO. JP-4 AVIATION FUEL. IF NOT AVAILABLE, REFER TO TB55-9150-200-24 FOR ALTERNATE FUEL</p>
29	Cut out corners 3 x 3 x 1 in. CH-47 prior to serial No. 68-15812, left side centered around window at sta 300 and right side at sta 380. CH-47, serial No. 68-15812 and subsequent, left side centered on sta 221.30 and 420, and right side at sta 416.50. See sheet 12 and 13. Aircraft black.	

Figure 9-10. Exterior Markings, CH-47 (Sheet 16 of 29)

CODE NO.	DIRECTIONS	WORDING
30	Top of fwd pylon aft of rain shield at sta 114. Top of letters facing inboard. Effective on CH-47, serial No. 66-19098 aircraft black.	HAND HOLD
31	Both sides of pylon on WL 118.00, start at sta 557 and extend aft. Lettering 6-in. lusterless black.	(insert serial no.)
32	On inside of aft transmission servicing access door. Above and below latch. 1/4-in. aircraft black letters.	MIL-L-7808 – CAP. 27 QUARTS, SUMP – 9 QUART SYSTEM. RUN FOR 3 MIN. UTES, SHUT DOWN — REFILL TO FULL MARK ON XMSN CASE
33	Left side of pylon adjacent to kick in step panels, aircraft black.	STEP
34	Lower aft section of fuselage in line with towing eye on tail gear both sides, sta 514, WL-28, aircraft black.	TOW ↓
35	Left side fuselage, sta 95, WL-25. CH-47D only, left side fuselage, sta 95, WL-25 and both sides of fuselage sta 488.5, WL-28. 1/2-in. aircraft black letters and arrows.	JACK POINT UNDER ↓
36	Both sides of fuselage, sta 483, WL-28 and sta 241, WL-34. CH-47D only, both sides of fuselage, sta 241, WL-34. 1/2-in. aircraft black letters and arrows.	FUSLJG JACK POINT AND MOORING POINT UNDER ↓
37	Both side of Aircraft. Most forward letter (U-left side, Y-right side) to start at STA 280.00, Top of letters will beat WL-12. Letters to be 6 in. high lusterless black. Additional dimensions and spacing in accordance with Fig 8-2.	UNITED STATES ARMY

Figure 9-10. Exterior Markings, CH-47 (Sheet 17 of 29)

CODE NO.	DIRECTIONS	WORDING
38	Both sides fuselage at sta 241, WL-34, aircraft black.	<p>FUSLG JACK POINT AND MOORING POINT UNDER</p> <p style="text-align: center;">↓</p>
38	CH-47D, both sides of fuselage, 1/2-in. aircraft black letters and arrow, sta 496, WL -28	<p>MOORING POINT UNDER</p> <p style="text-align: center;">↓</p>
39	Aft of external power access panel on left side, aircraft black. NOTE: CH-47A, aft of access door at sta 174. CH-47C, below access door at sta 169. CH 47D, sta 163, WL-23.	115/208 V 400 CYCLE A.C.
40	Above exmnal power access panel, sta 169, on left side, aircraft black.	EXT PWR DC-AC
41	Fwd of external power access panel on left side, sta 166, 1/2-in. aircraft black letters.	28 V.D.C.
42	Below door jettison handle on left side, sta 93, WL 24, aircraft black.	<p>DOOR JETTISON PUSH TRIGGER TURN HANDLE DOWN</p> <p style="text-align: right;">↓</p>
43	Left side of fuselage aft of cabin window, sta 93, WL 11.50. First two lines 1-in, remain ing lines 1/2-in. aircraft black.	<p>U.S. ARMY MODEL CH-47A (B, C or D) U.S.A. SERIAL NO. (insert serial no.)</p> <p>Service this aircraft with MIL-T-5624 grade No. JP-4 aviation fuel. If not available refer to TB55-9 150-200-24 for alternate fuel.</p>
44	Below lower flight compartment side win dow in line with door jettison handle on left side aircraft black. FOR TACTICAL HELICOPTERS ONLY.	DOOR JETTISON
45	On aft pylon structure visible when work platform doors are open approx WL+116.0 and Sta 545.0. Right and left hand side, 1/4-in, aircraft black letters.	WARNING FILTER MAINTENANCE REQUIRED WHEN RED INDICATOR IS EXTENDED

Figure 9-10. Exterior Markings, CH-47 (Sheet 18 of 29)


CODE NO.	DIRECTIONS	WORDING
46	Right side of rear pylon, inside compartment, on access doors. 1/2-in. aircraft black letters.	COMBINING GEAR BOX OIL CAP. 23 QT SUMP – 16 QT SYSTEM, RUN ENGINES 3 MINUTES, SHUT DOWN – REFULL XMSN CASE, SERVICE WITH MIL-L.7808 OIL
47	Apply to transmission in area of filler cap. 1/2-in. aircraft black letters.	RUN FOR 3 MINUTES. SHUT DOWN REFILL TO FULL MARK ON XMSN CASE
48	Authorized placement of unit insignia is on nose access panel.	
49	Above battery vent, left side of fuselage, sta 188. 1/4-in. aircraft black letters.	BATTERY VENT
50	On battery access panel, left side of fuselage, sta 188, WL 16, aircraft black.	BATTERY INSIDE
51	Black walkway material on indicated shaded areas	
52	Paint code 1/4-in. black letters left side of fuselage, sta 118, WL 28. **Contractor will insert their name code.	**WP1-P2-L3 Date WP - indicate wash primer used P - indicate primer used L. indicate lacquer used (if req'd) C - indicate coating used (if req'd)
53	Both sides of fwd pylon fairing, sta 100, WL 67.50, black.	ACCESS FWD ROTOR SYSTEM & WORK PLATFORM
53	Both sides of fwd pylon fairing, 1/2-in, black letters, sta 97.50 WL+67. CH-47D only.	ACCESS FWD ROTOR SYS HYDR COMPT WORK PLATFORM
54	Inside on side wall, black letters on orange.	TRANSFORMER RECTIFIER COOLING DUCT, DO NOT COVER
55	Both sides of fwd pylon, sta 123, WL 63.50 aircraft black.	AIRCRAFT LIFT PTS INSIDE 

Figure 9-10. Exterior Markings, CH-47 (Sheet 19 of 29)



CODE NO.	DIRECTIONS	WORDING
56	Left side of fuselage, sta 162, above drain tube. 1/4-in. black letters.	TUNNEL DRAIN
57	Both sides of fuselage. 2 places, sta 226 and 355, WL -34.0. 1/2-in. black letters.	COMPT DRAINS UNDER 
58	Both sides of fuselage, 1/2-in. aircraft black letters, sta 241, WL-18. CH-47D only, right side fuselage, sta 253, WL-13.	ACCESS LANDING GEAR SERVICE
59	Both sides of fuselage, sta 241, WL-23.0. Centered on forward landing gear access door, black.	ACCESS FUEL SYSTEM INSP.
60	On landing gear struts, 1/4-in. black letters. * Refer to TM 55-1520-209-23, TM 55-1520-227-23, or TM 55-1520-240-23 for affected aircraft and tire pressure.	TIRE PRESSURE *67PSI *88PSI
61	Both sides of fuselage, aircraft black. CH-47 prior to serial No, 67-18494, 8 places at sta 266, 379, 395, and 416. CH-47 after serial No. 67-18494, 14 places at sta 195, 235, 261, 268, 369, 379, 435, and 445. CH-47D, both sides of fuselage, 18 places at sta 194.1, 235.2, 261.2, 268.7, 363.6, 379.0, 396.2, 437.7, 443.5, 435.7, 369.6, 195.9.	FUEL DRAIN 
62	Both sides of fuselage, 2 places, sta 261 and 355. CH-47D only, sta 261, 370.50, Black letters.	Disconnect electrical plugs in fuel cell access panel before dropping tank.
63	DELETE	

Figure 9-10. Exterior Markings, CH-47 (Sheet 20 of 29)




CODE NO.	DIRECTIONS	WORDING
64	Both sides of fuselage under antenna, sta 330.5, WL 14.9, black.	NO HAND HOLD
65	Both sides of fuselage centered on access plate, sta 380 and 449, aircraft black. CH-47D, sta 381, 449.	ACCESS FUEL SYSTEM INSP
66	Left and right aft work platform, centered on platform at WL-2.50, black letters.	WORK PLATFORM
67	Both sides of fuselage, fore and aft of work platform above support point at sta 474.0 and 521.0, WL-6.0 black letters.	WORK PLATFORM SUPPORT POINT 
68	Both sides of fuselage, sta 485, WL-34. 1/2-in. black letters as required per model helicopter.	COMPT DRAINS UNDER 
69	Left side of fuselage, sta 546.50, WL 15, black letters.	ACCESS APP EMERG FLUID SHUT OFF
70	Left side of fuselage, sta 543, WL 50. First line 1-in. black letters, remaining letters 1/4-in., located in front of each overboard drain tube. *NOTE: Applicable on CH-47, serial No. 67-18494 and subsequent.	ENGINE DRAINS *STARTER RELIEF VALVE DRAIN HYDRAULIC DRAIN AFT XMSN DRIP PAN ENGINE COMB CHAMB ENGINE BREATHER ENGINE MANF
71	Both sides of engine cowling below screened air intake, sta 486, WL 46.0, black letters.	ACCESS ENGINE QUICK DISCONNECT
72	Both sides of rear pylon, sta 471, WL 79, black letters.	AIRCRAFT LIFT PTS INSIDE 

Figure 9-10. Exterior Markings, CH-47 (Sheet 21 of 29)

CODE NO.	DIRECTIONS	WORDING
73	Both sides of rear pylon, sta 457, WL 106.5, fwd of screened air intake, black letters.	ACCESS XMSN OIL COOLER
74	On CH-47, serial No. 65-7966 to 65-8025, left side of rear pylon, below screened area black letters.	ACCESS ENGINE GEAR BOX CHIP DETECTORS
75	On outboard side of #1 engine and inboard side of #2 engine, aft of access door, black letters.	ACCESS OIL QUANTITY INDICATOR
76	DELETE	
77	DELETE	
78	Left side of fuselage near top of rear pylon, sta 550, WL 128, black letters.	ACCESS THRUST BEARING & WORK PLATFORM
79	DELETE	
80	Both side of pylon centered on access door, sta 564, WL 85.0, black letters.	ACCESS XMSN
81	DELETE	
82	Right side of fuselage under overboard drain, sta 107, WL 15, 1/2 in. black letters.	WATER DRAIN HEATER INLET
83	Right side of fuselage above access door, sta 114, WL-1, black letters.	INPH JACK
84	Right side of fuselage, under phone jack plug, sta 112, WL-12, black letters. Effective CH-47, serial No. 66-19098 thru 68-15828.	BLADE TRACKING
85	Right side of fuselage above overboard drain line, sta 101, WL -34.5 1/2-in. black letters.	HEATER FUEL DRAIN
86	Right side of fuselage on upper door, fwd of release handle, sta 127, WL-2.5, black letters.	LIFT DOOR UP

Figure 9-10. Exterior Markings, CH-47 (Sheet 22 of 29)

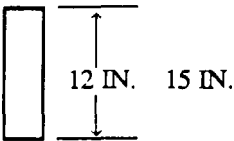
CODE NO.	DIRECTIONS	WORDING
87	Both sides of aft fuselage inside inside panel, black letters.	NO HAND HOLD
88	Right side of fwd pylon fairing, sta 78, WL 66, black letters.	XMSN OIL FILLER INSIDE
89	Right side of fuselage on access door, sta 187, WL-15. black letters.	ACCESS A.C. POWER EQUIP
90	<p>Right side of fuselage adjacent to each side of step kick in door panel</p> <p style="text-align: center;">NOTE</p> <p>Effective CH-47B, serial No. 66-19098 and subsequent the first two lower steps on the right side of the pod have a folding hinge type door. This marking goes on the door of the step below the door knob. First line is 1-in, remainder is 1/2-in. black letters.</p>	<p>STEP</p> <p>STEP PULL KNOB DOWN AND OUT TO OPEN STEP</p>
91	Both sides of fuselage, step guide above each step. 1/4-in. wide, 12-in., 15-in., or 27-in. lengths, black letters.	
92	Outboard side of each nose antenna mounting tube. First line centered horizontally on tube, second line below center. 1/2-in. black letters.	NO PUSH KEEP OFF
93	Right side of fuselage, aft small access plate, on larger access plate, sta 494.50, black letters.	ACCESS RAMP CONTROL DN-STOP-UP
94	Right side of fuselage above access plate, sta 487.50 black letters,	INPH JACK
95	Right side of fuselage on aft access panel near tail, sta 561, WL 15, black letters.	HYD SYSTEM TEST PANEL
96	DELETE	

Figure 9-10. Exterior Markings, CH-47 (Sheet 23 of 29)



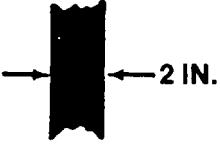
CODE NO.	DIRECTIONS	WORDING
97	Both aft landing gear drag struts, 1/2 in. aircraft black letters. Effective CH-47, serial No. 63-7922 and subsequent.	WARNING DO NOT LOAD GEAR WITH STATIC LOCK ENGAGED
98	Both aft landing gear drag links. MIL-C-46166, aircraft red. No. 31136, arrow 1 in. x 3 in. Effective CH-47 serial No. 63-7922 and subsequent.	
99	Both aft landing gear on aft side of swivel lock actuator. 1/2-in. aircraft black letters. Stencil vertical on actuator. Effective CH-47 serial No. 63-7922 and subsequent.	WARNING . REFER TO MANUAL BEFORE DISCONN HYD LINES
100	<p>Right side of fuselage, near tail, first two lines 1-in. black letters. Remainder of stencil 1/4 in. Each line will be placed fwd of overboard drain tube.</p> <p style="text-align: center;">NOTE</p> <p>*Shown for CH-47, serial No 66-19032 and subsequent **On CH-47 prior to serial No. 66-19032, reverse first two lines #Applicable on CH-47, serial No. 67-18494 and subsequent</p>	<p style="text-align: center;">ENGINE DRAINS</p> <p>#O STARTER RELIEF VALVE DRAIN *O APP FUEL PUMP SEAL **o APP COMB CHAMB o HYDRAULIC DRAIN o ENGINE COMB CHAMB o ENGINE BREATHER o ENGINE MANF</p>
101	Finish of door handle and emer door and cockpit handles, both sides of helicopter. Paint aircraft black.	
102	On top of tunnel facing left of walkway area. Starting at sta 200, BL 6 right hand side, and spaced 40-in. apart, black letters.	NO STEP
103	Centered on top of fwd pylon at sta 134, black letters.	NO STEP
104	Top of fuselage around all walkway areas, 2-in. in black border.	

Figure 9-10. Exterior Markings, CH-47 (Sheet 24 of 29)


CODE NO.	DIRECTIONS	WORDING
105	Top of fuselage, right side, fwd on access door, sta 152. Top of black letters facing outboard. Also right side aft sta 443.5 on CH-47 serial No, 66-19098 thru 67-18484.	ACCESS MAINT DAVIT
106	Top of fuselage, right side aft of walkway indent sta 175. Also aft right side, of fuselage at sta 416. 1/2-in. black letters.	MAINT CRANE AZIMUTH PT. REPLACE SCREW AFTER USING
107	Three places on top of fuselage tunnel, sta 180,303, and 384. Top of black letters facing left	ACCESS DRIVE SHAFT COUPLING
108	Top center of both sides of fuselage, sta 317. A 2-in. lusterless black circle on the fitting cover.	
109	Top center of both sides of fuselage at fitting. Stencil to be outbd of fitting, top of black letters facing outbd.	SPT. PT BLADE RACK
110	Top and bottom of left and right gear box access cover. Top of black letters face aft.	REMOVE GEAR BOX ACCESS
111	DELETE	
112	Top of left and right engine pod drive shaft fairing. Top of black letters facing aft	ACCESS DRIVE SHAFT
113	On top of left and right nacelle on access plate. Top of black letters facing aft.	ACCESS OIL FILTER
114	Two places on top of left and right nacelle. Aft of oil filler access and fwd of circular hole in fairing. Top of black letters face aft.	ACCESS ENGINE HOIST
115	Top of left and right engine nacelle, fwd of tail pipe. Top of black letters facing outboard, arrows to point aft.	NO STEP OR HAND HOLD
116	On top sides of fwd and aft rotor blade rain shield. Paint rain shield lusterless black (overspray rain shield). Apply stencils 120° apart 3 places on each rain shield. This stencil is located outboard of each rotor blade pitch link cut-out hole	NO STEP

Figure 9-10. Exterior Markings, CH-47 (Sheet 25 of 29)



CODE NO.	DIRECTIONS	WORDING
117	Fore and aft rotor blade rain shield, 3 places positioned 120° apart, 1/4-in. black letters, paint rivet orange. There are 3 round head rivets on the outboard side of each rain shield. These will be painted orange with the 1/4-in. stencil located above the rivet.	PHASING (rivet ref)
118	Bottom centerline of fuselage, One place on front lower section of nose area. Two places on nose at mirror support brackets. 1/2-in. black letters.	MIRROR SPT PT
119	Bottom of fuselage, right side, at sta 98.0. 1/4-in. black letters.	XMSN OIL DRAIN
120	Bottom of fuselage at drain lines. Stencil aft of sta 430. On CH-47 serial No. 66-19098 thru 68-15831, 17 places. On CH-47 serial No. 68-15832 and subsequent, 26 places. Decals forward of Station 430, black letters.	DRAIN OPEN 
121	Left side of fuselage, bottom of acft. sta 187. 1/4-in. black letters.	BATTERY DRAIN
122	On aft loading ramp emergency escape panel. 1-1/2 in. black band around push button	
123	1/2-in. black letters on transmission. Effective 66-19098 thru 67-18473	MAGNETIC PLUG
124	On CH-47A, fwd side of front pylon above static port at WL 72.5, left and right side, front. Top line 1/2-in. black letters, second line 1/4-in. letters.	S.A.S. UPPER
125	On CH-47A, fwd side of front pylon, below static port, at base of fairing, left and right side, front. Top line 1/2-in. second line 1/4-in. black letters.	S.A.S. LOWER
126	Centered on nose panel, above door catch black letters.	ACCESS
127	Left side of fuselage above drain line, 1/4-in. black letters. CH-47A, sta 525, WL 7.0 CH-47C, sta 4-17 at bottom of access plate.	APP FUEL DRAIN

Figure 9-10. Exterior Markings, CH-47 (Sheet 26 of 29)

CODE NO.	DIRECTIONS	WORDING
128	Effective CH-47B and C, serial No. 67-18776 and subsequent that have ARC-102 antenna installed along left side of fuselage. 2 places above antenna lead-in, at fwd end of fuselage, aft of last standoff at end of fuselage, black letters.	DANGER . HIGH VOLTAGE DO NOT TOUCH ANTENNA WIRE
129	Effective CH-47B, C, and D, serial No. 67-18446 and subsequent, with ARC-102 antenna installed, 5 places besides antenna standoffs, black letters.	NO HANDHOLD
130	CH-47B and C located on lower cockpit windshield, curves around upper SAS part, black letters. CH-47D only.	HIGH TEMP UPPER SAS DANGER DO NOT PLUG OR DEFORM HOLES HIGH TEMP#1 SIDE SLIP DANGER DO NOT PLUG OR DEFORM HOLES
131	CH-47B and C, located on lower cockpit windshield, curves around lower SAS part. Aircraft black letters on a transparent background. NOTE Area around static port must be smooth and clean. CH-47D only.	DO NOT PLUG OR DEFORM HOLES HIGH TEMP LOWER SAS DANGER DO NOT PLUG OR DEFORM HOLES HIGH TEMP #2 SIDE SLIP DANGER
132	Outboard side of fwd pylon work platform when platform is open. Facing aft, black letters.	MAX WEIGHT 400 LBS
133	On left and right fwd pylon work platform. 5 places, facing outboard on outboard side, facing aft on fwd and aft sides. black letters.	NO STEP
134	On aft work platform one facing fwd, one facing aft black letters.	MAX WEIGHT 400 LBS
135	On work platform. 6 places, 2 facing in-board, 2 facing outboard, 1 facing fwd, and 1 facing aft black letters.	NO STEP
136	Engine work platform area. On side of fuselage when engine work platform is open. Between sta 502 and 518, WL -2.50 black letters.	MAX WEIGHT – 400 LBS ON WORK PLATFORM

Figure 9-10. Exterior Markings, CH-47 (Sheet 27 of 29)

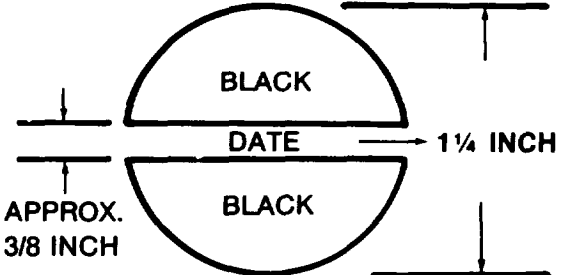
CODE NO.	DIRECTIONS	WORDING
137	In electrical panel black letters.	1151VAC
138	In electrical panel black letters.	INPH
139	In electrical panel. 1/4-in. black letters.	BLADE TCK
140	In electrical panel. 1/4-in. black letters.	PHASE DET
141	Both sides of fwd fuselage, 1/2-in. black letters, sta 72, WL -19. ***insert 209 for CH-47A *** Insert 227 for CH-47B/C ***Insert 240 for CH-47D	CAUTION WHEN INSTALLING DOOR REFER TO TM 55-1520.***-23 CHAPTER 2 SECT I FOR PROPER INSTALLATION AND ADJUSTMENT
142	Left side aft pylon, 1/2-in. aircraft black letters, sta 472, WL 73, CH-47D only.	LS ENGINE XMSN FILTER AND DRAIN ACCESS
143	Left side fuselage, below Code 52, paint aircraft black. NOTE: Date shown on stencil is date aircraft painted with MIL-C-46168 paint.	
144	Left side fuselage, 1/2-in. black letters, sta 157.50, WL-14, CH-47D only.	GROUND TEST CONNECTION FLIGHT CONTROL SYSTEM 1 3000 PSI USE HYDRAULIC FLUID MI L-H-83282
145	Both sides fuselage, 1/2-in. black letters, sta 173, WL -15, CH-47D only.	ACCESS AC-DC POWER EQPT
146	Right side fwd pylon, 1/2-in. aircraft black letters, sta 153, WL 72 CH-47D only.	ACCESS HYDR RESERVOIR
147	Left side fuselage, 1/2-in. black letters, sta 245, WL -13, CH-47D only.	ACCESS LANDING GEAR SERVICE
148	Top of both engine cowlings, 1/2-in. aircraft black letters, sta 490.5, WL81.5	ACS HYDR RSVR INSP

Figure 9-10. Exterior Markings, CH-47 (Sheet 28 of 29)

CODE NO.	DIRECTIONS	WORDING
149	Both sides of aft pylon inside reservoir cooler access covers 1/2-in aircraft black letters, CH-47D only	REMOVE BONDING JUMPER WHEN DOOR IS TO BE REMOVED INSTALL BONDING JUMPER WHEN INSTALLING DOOR
150	Both sides aft pylon, 1/2-in. aircraft black letters, sta 525.80, WL 84.50, CH-47D only.	ACCESS HYDRAULIC COMPARTMENT
151	Both sides of aft pylon, 1/2-in. aircraft black letters, sta 613.70, WL 102.0, CH-47D only	FRAGILE ANTENNA DO NOT PUSH
152	Right side aft fuselage, 1/2-in. aircraft black letters, sta 565.25, WL 15.50, CH-47D only.	GROUND TEST CONNECTION FLIGHT CONTROL SYSTEM 1 3000 PSI USE HYDRAULIC FLUID MIL-H-83282
153	Both engine cowlings, fwd of screened air intake, 1/2-in. aircraft black letters, sta 486, WL 46, CH-47D only	ACCESS ENGINE QUICK DISCONNECTS
154	Right side aft pylon, 1/2-in. aircraft black letters, sta 472, WL 73, CH-47D only.	RS ENGINE XMSN FILTER AND DRAIN ACCESS
155	Right side aft pylon, 1/2-in. aircraft black letters, sta 505, WL 27, CH-47D only.	ACCESS HYDR COOLING FANS
156	Front of aircraft, 1/2-in. aircraft black letters, center, WL 41, CH-47D only.	NO HAND HOLD
157	Bottom of fuselage, both sides, 1/2-in. aircraft black letters, sta 434, 368, 233, BL 53, CH-47D only.	FUEL DRAIN - VENT
158	Both sides of fuselage, 1/2-in. aircraft black letters, sta 395,267, 194, BL 53, CH-47D only.	FUEL DRAIN

Figure 9-10. Exterior Markings, CH-47 (Sheet 29 of 29)

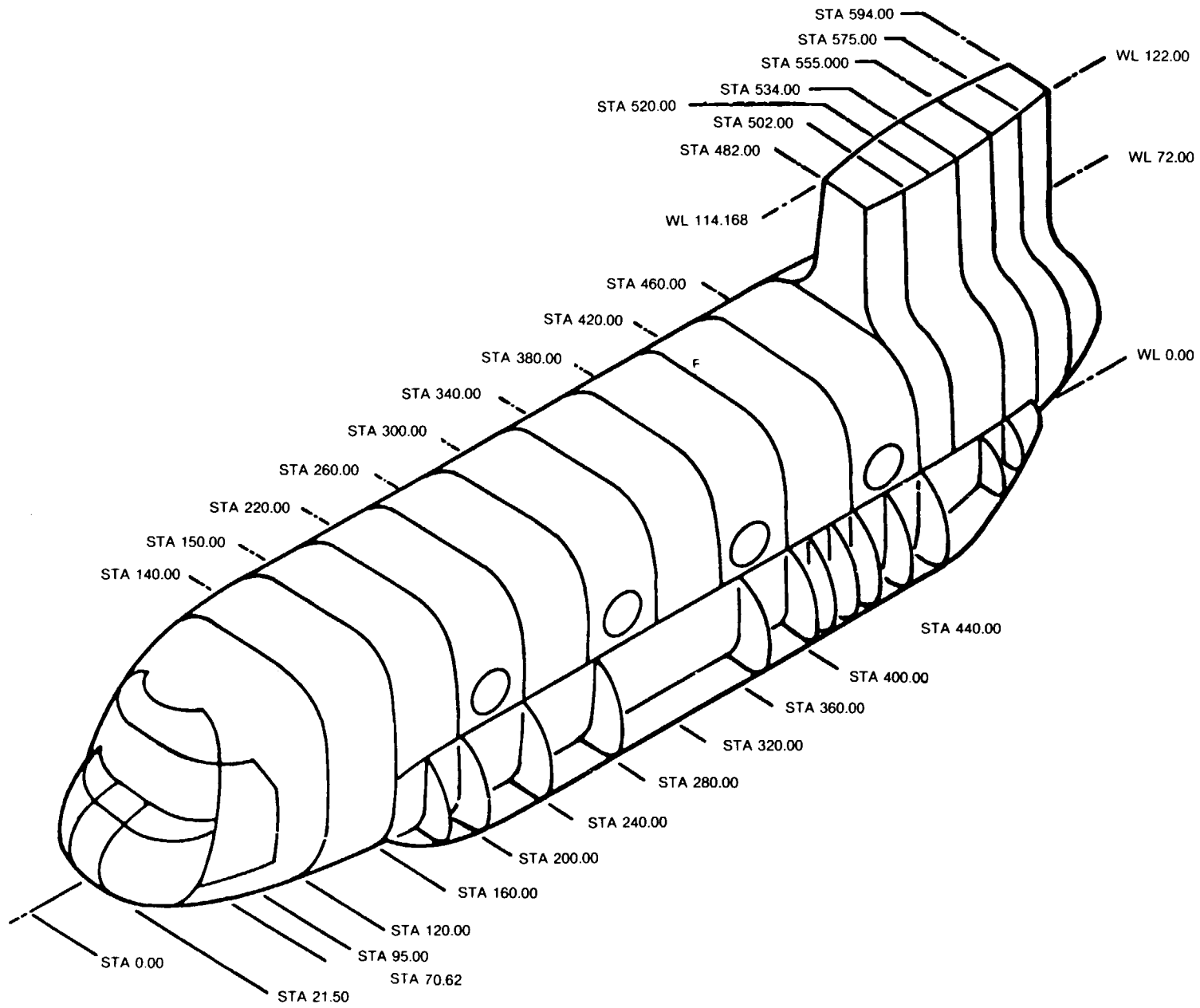
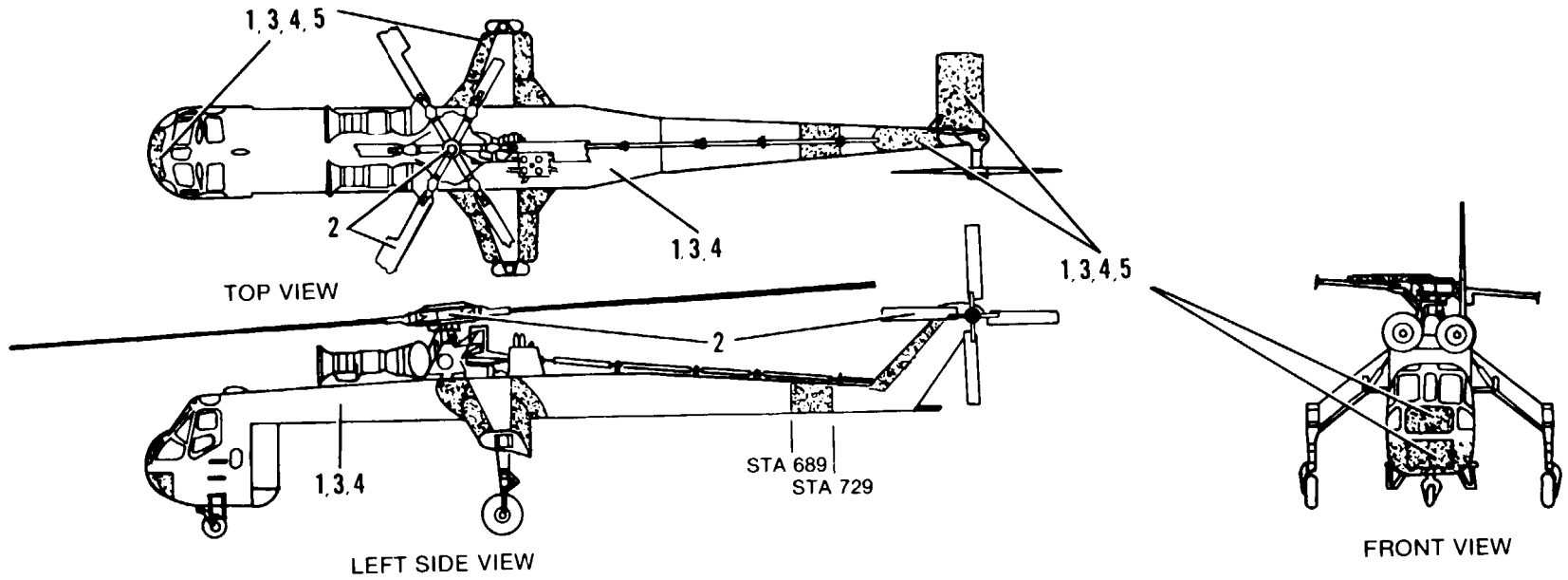
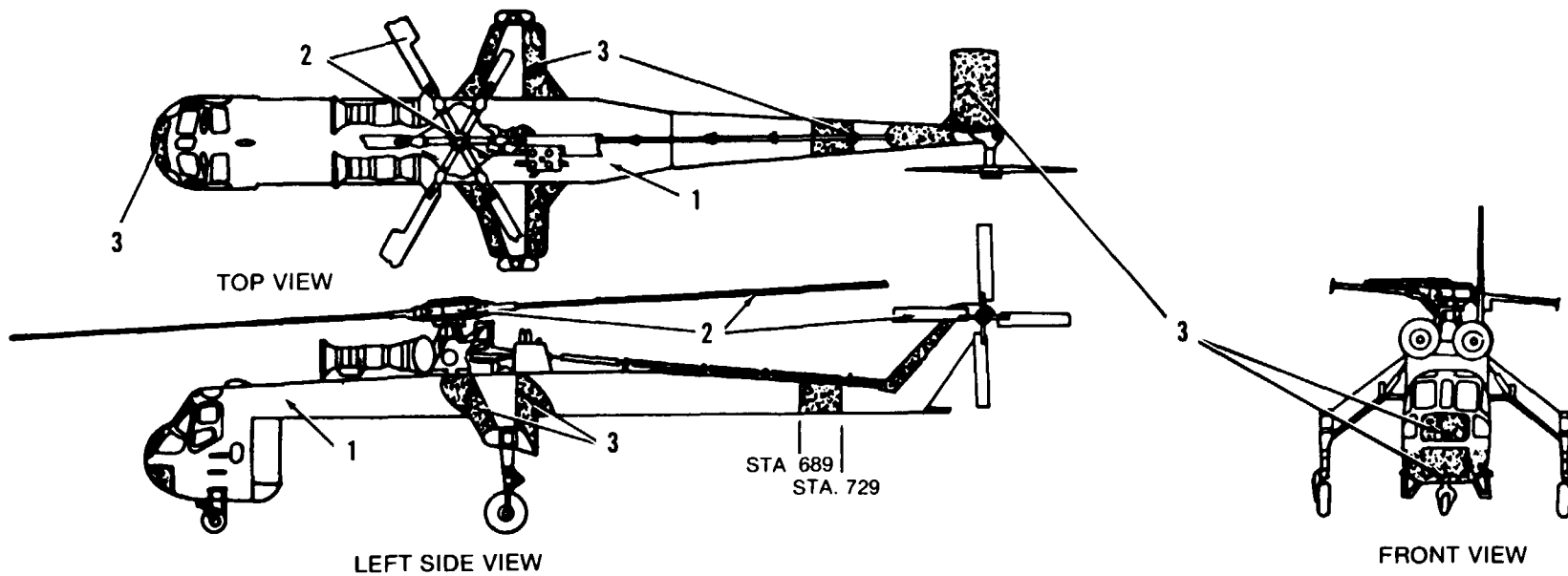


Figure 9-11. Station Diagram, CH-47.



1. MIL-C-46168, Aircraft Green (entire aircraft, except as noted).
2. MIL-C-46168, Aircraft Black.
3. MIL-C-46168, Dark Sand (entire aircraft or high conspicuous paint scheme when authorized, desert operations only). See Paragraph 5-11.
4. MIL-C-46168, Aircraft White (entire aircraft or high conspicuous paint scheme when authorized, arctic operations only). See Paragraph 5-11.
5. MIL-P-21600, Fluorescent Red-Orange. ANA #633 (training aircraft-high visibility, only where authorized).

Figure 9-12. Tactical Paint Scheme, CH-54



1. MIL-C-46168, aircraft green (entire aircraft, except where noted).
2. MIL-C-46168, aircraft black.
3. MIL-P-21600, fluorescent red-orange, ANA #633 (shaded areas only).

Figure 9-13. Non-Tactical Arctic/Desert Paint Scheme, CH-54

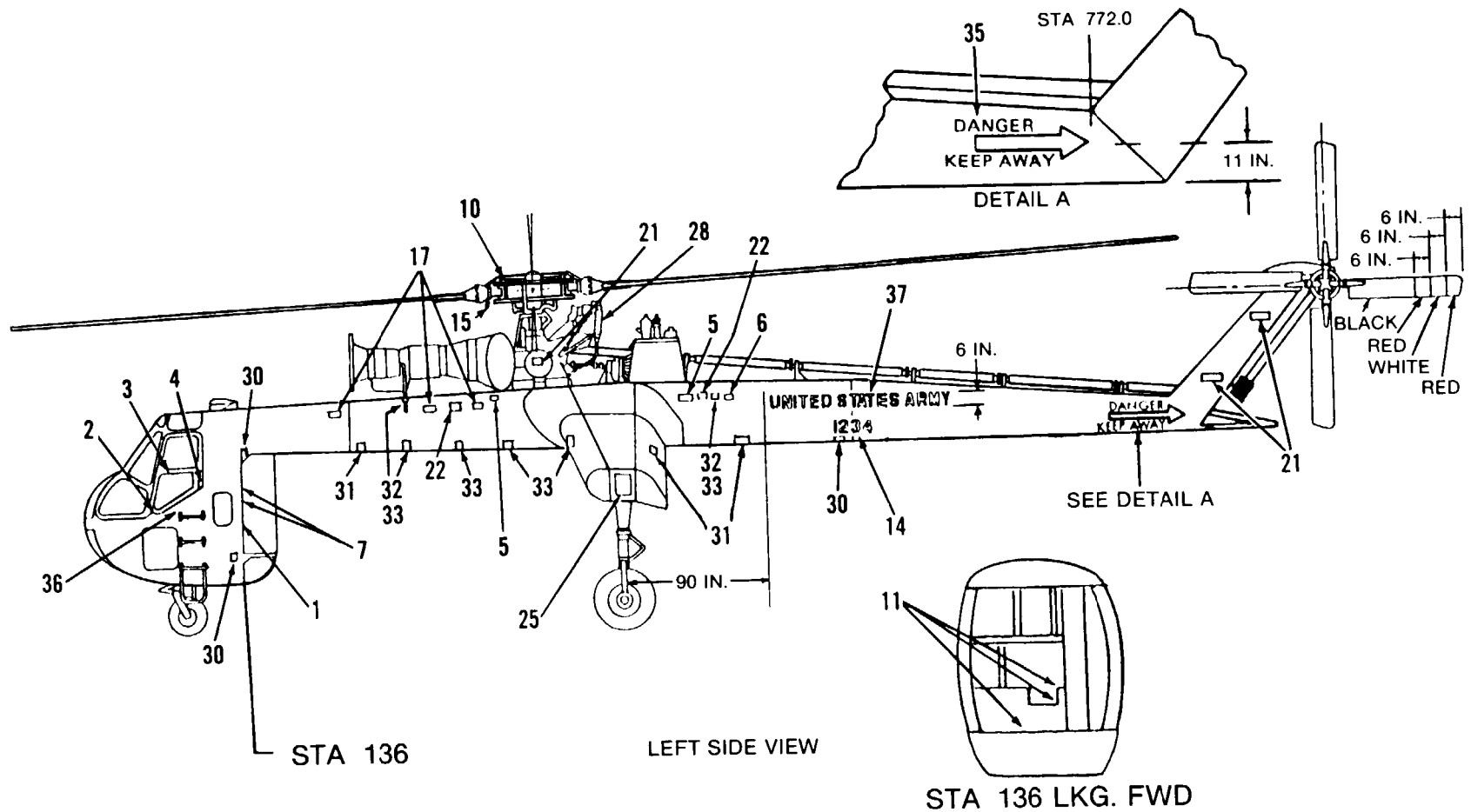


Figure 9-14. Exterior and Interior Markings, CH-54 (Sheet 1 of 7)

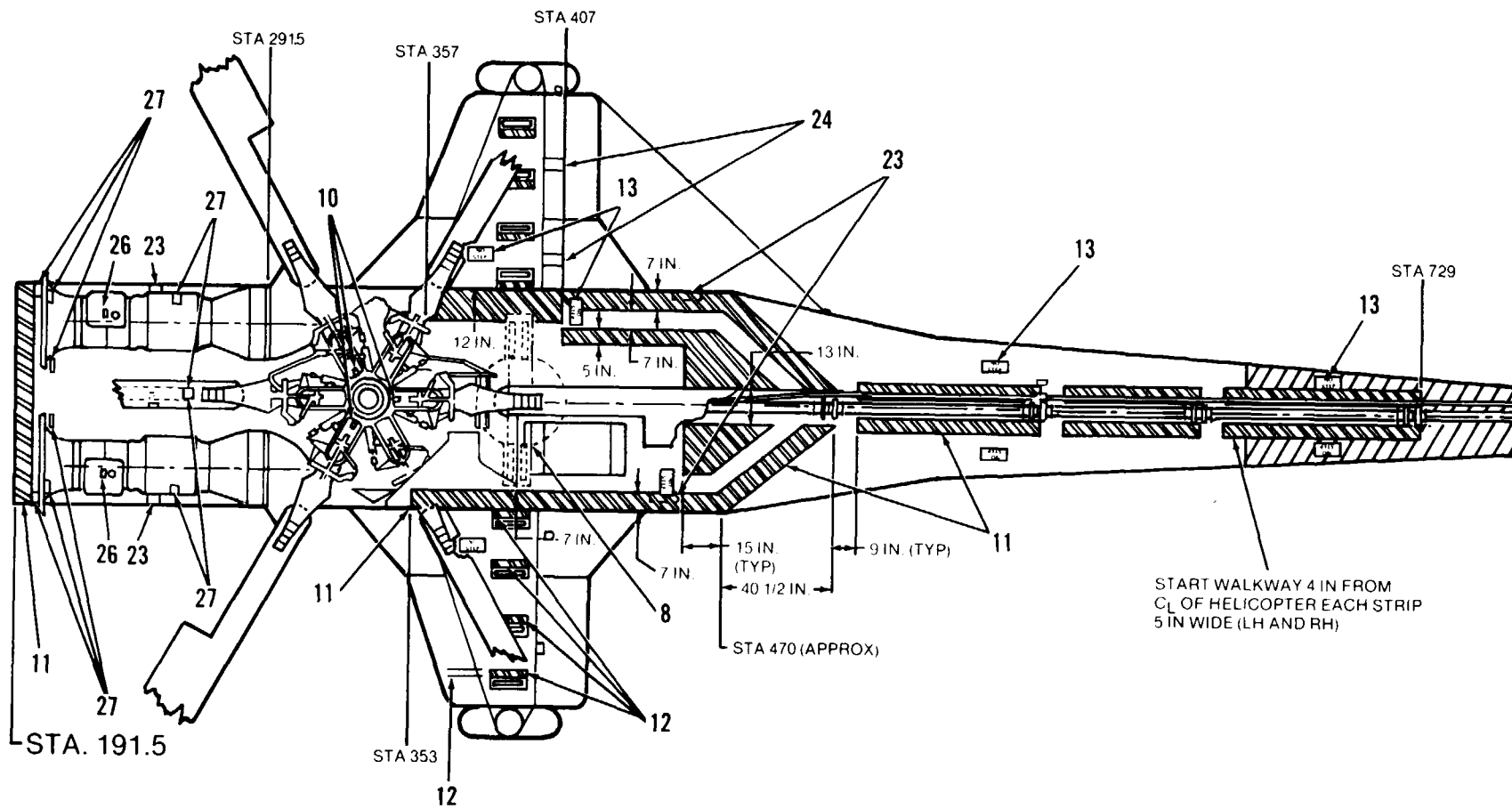


Figure 9-14. Exterior and Interior Markings, CH-54 (Sheet 2 of 7)

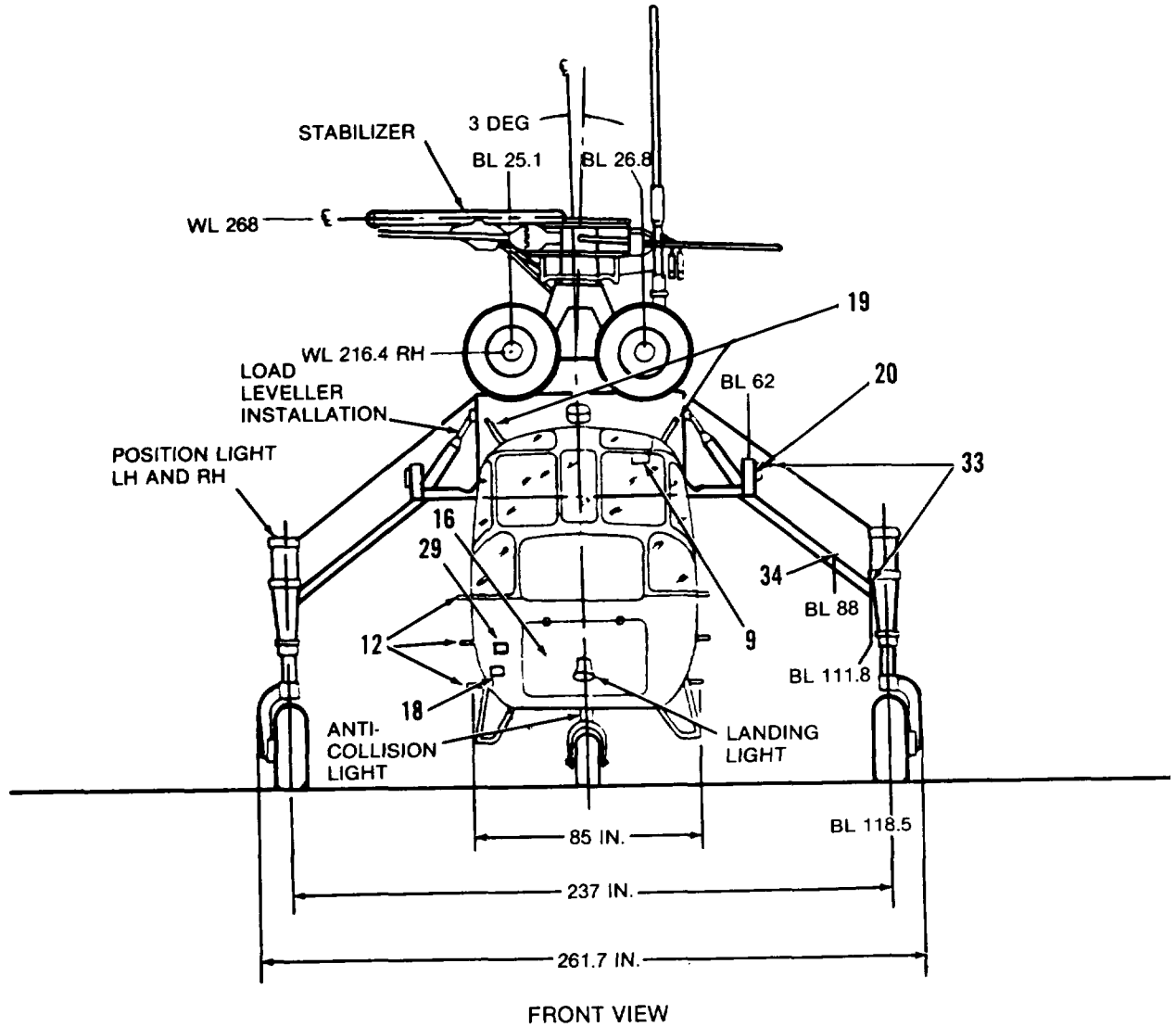


Figure 9-14. Exterior and Interior Markings, CH-54 (Sheet 3 of 7)

CODE NO.	DIRECTIONS	WORDING	
1	Rear cockpit door handle, exterior and interior, 1/2-in. MIL-C-46168, aircraft black #37038 letters	TO OPEN PUSH AND TURN (EXTERIOR) ↓	TO OPEN PULL AND TURN (INTERIOR, YELLOW LETTER) ←
2	Cockpit door by emergency release handle station 73, WL 129, right and left side, 1/2-in. black letters.	EMERGENCY RELEASE TURN ↓	EMERGENCY EXIT PUSH
3	Cockpit door by handle, interior, right and left side, 1/2-in. black letters,	TO OPEN TURN ↑	
4	Cockpit door by handle, exterior, right and left side, 1/2-in. black letters.	TO OPEN TURN	
5	On left side of fuselage near fwd filler cap station 303 and aft filler cap station 419 (approx), 1/2-in. black letters.	FUEL MIL-T-5624 JP-4	
6	On left side of fuselage near auxiliary filler cap station 439, 1/2-in. black letters.	FUEL MIL-T-5624 JP-4	
7	Rear door by emergency release handle on exterior and interior bulkhead, station 136, 2-in. black letters.	(EXTERIOR WI 104.50 B1 23 EMERGENCY RELEASE TURN ↑ INTERIOR EMERGENCY EXIT TURN ↑ W1 147.50	
8	On auxiliary power plant oil tank 1/2-in. black letters.	LUB OIL MIL-L-23699	
9	In pilot's compartment on canted bulkhead aft of pilot's seats, 1-1/2-in. black letters.	WARNING. DO NOT MOVE HELICOPTER UNLESS CROSS BRACE IS INSTALLED	
10	On torque tube arms Nos. 2,4, and 6 of main rotor head, 1/2-in. black letters.	LIFT →	

Figure 9-14. Exterior and Interior Markings, CH-54 (Sheet 4 of 7)






CODE NO.	DIRECTIONS	WORDING
11	Apply non-skid conating, MI L-W-5044, Type II, from walkway area station 353 to station 729, from station 191.5, a strip 10 in. wide transverse in the aft direction, and on pilot's compartment floor and steps forward of station 136. Paint black.	
12	Apply 3 in. strip of non-skid coating, left and right side. Paint black.	
13	Apply 1-in. black letters.	NO STEP
14	Paint black radio call number for tactical aircraft 6 in. high spaced 10 in. from bottom of boom.	<div style="display: flex; justify-content: space-around; width: 100%;"> 1 2 3 4 </div>
15	CH-54B. Droop stops (Cam Arm P/N 65105-11002-101 and -102) to be painted black with the lower 1-1/2 in. painted MI L-C-46168, aircraft red, #31136.	
16	FOR TACTICAL AIRCRAFT ONLY Authorized placement of unit insignia is on the nose.	
17	Both sides above control rods at station 205, 206, and 300, WL 185, 1/2-in. black letters.	<div style="text-align: center;">  NO STEP NO HAND HOLD  </div>
18	Inside of battery compartment door, right side of aircraft on window washer, 1/2-in. black letters.	REMOVE CAP  TO FILL RESERVOIR CAP 2 QTS.
19	Pitot tubes, both sides, top of cockpit, 1/2-in. black letters.	NO HANDHOLD  1/2" red stripe HANDHOLD
20	On cargo lashing reels below rocking mechanisms, 4 places, 1/2-in. black letters.	 LOCKED POSITION
21	Left side main gear box near oil filter, left side of pylon near intermediate gear box, and on left side of pylon near tail gear box, 1/2-in. black letters.	OIL FSN 9150-180-6278 TB 55-9150-200-24
22	Left side of fuselage, fwd and aft filler caps. Letters to be 1/2-in. black. (See MS27606-2 for dimensions.)	

Figure 9-14. Exterior and Interior Markings, CH-54 (Sheet 5 of 7)

CODE NO.	DIRECTIONS	WORDING
23	2 in. black numbers on bottom side of fuselage, stations 246 and 430, BL38.1 and 2 on right side, 3 and 4 on left side.	1 3 2 4
24	On left right side fwd main gear fairing, station 405, WL 194 and 160, 1 in. black letters, 4 places.	NO STEP
25	Left side main gear, 1/2-in. black letters.	FUEL PRESSURE SERVICING POINT FUEL JP 4
26	Near oil filter cap on left and right engines, 1/2-in. black letters.	OIL CAP 1.0 GAL MI L-L-23699
27	Apply stencils on left and right engine brackets, armor plate, and top side of helicopter, 1/2-in. black letters, 10 places Sta. 208 BL. 35.00 Left side Sta. 208 BL. 35.00 Right side Sta. 213 BL. 9.25 Left side Sta. 213 BL. 9.25 Right side Sta. 213 BL. 36.40 Left side Sta. 213 BL. 36.40 Right side Sta. 254 BL. 35.00 Left side Sta. 254 BL. 35.00 Right side Sta. 260 BL. 0.00 Left side Sta. 260 BL. 0.00 Right side	FIRE DETECTOR NO. 2 FIRE DETECTOR NO. 1 FIRE DETECTOR NO. 4 FIRE DETECTOR NO. 5 FIRE DETECTOR NO. 3 FIRE DETECTOR NO. 4 FIRE DETECTOR NO. 5 FIRE DETECTOR NO. 3 FIRE DETECTOR NO. 1 FIRE DETECTOR NO. 2
28	Below APV fire surveillance on top side of aircraft, station 371, BL3.87 on left side. On bracket attached to oil cooler, station 384, WL 231, right side, 1/2-in. black letters.	FIRE DETECTOR NO. 2 FIRE DETECTOR NO. 1

Figure 9-14. Exterior and Interior Markings, CH-54 (Sheet 6 of 7)

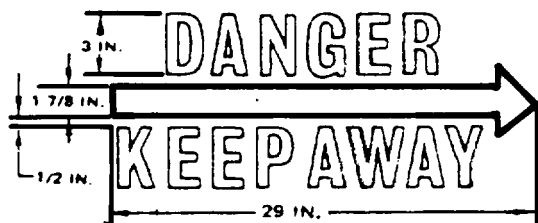
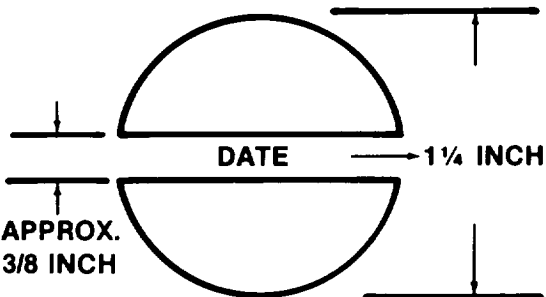
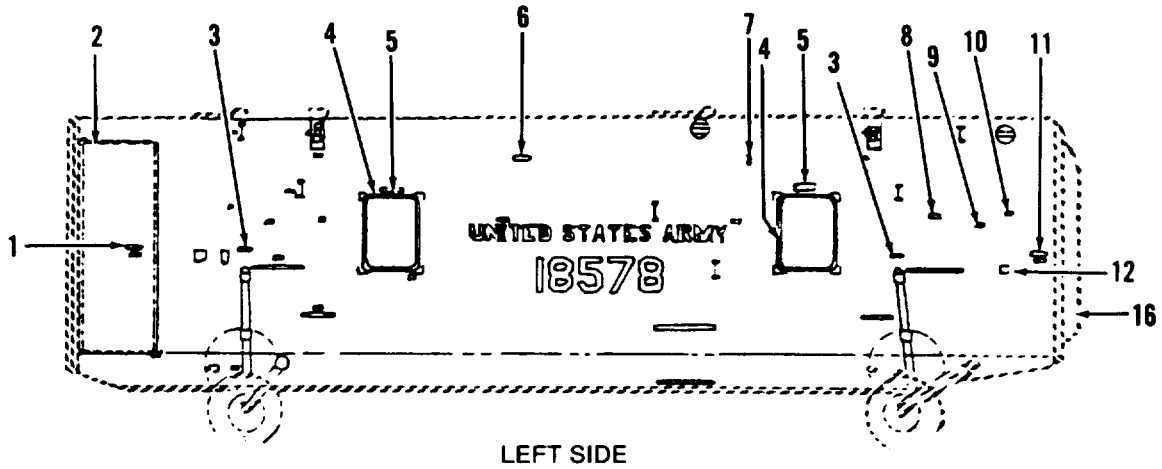
CODE NO.	DIRECTIONS	WORDING
29	On fwd fuselage, right side only, below cockpit window, 1/2-in. black letters.	EXT POWER 115 VOLTS AC EXT POWER 28 VOLTS DC
30	Apply static load markings to bottom surface of aircraft where practical, 6 places, 1/2-in. black letters.	STATIC LOAD 3000 LBS.
31	Apply static load markings to bottom surface of aircraft, 8 places, 1/2-in. black letters.	STATIC LOAD 5000 LBS.
32	CH-54A. Apply static load markings to bottom surface of aircraft where practical, 8 places, 1/2-in. black letters.	STATIC LOAD 7000 LBS.
33	CH-54B. Apply static load markings to bottom surface of aircraft where practical, 8 places, 1/2-in. black letters.	STATIC LOAD 10,000 LBS.
34	Apply static load markings to bottom surface of aircraft, 12-in. black letters.	STATIC LOAD 2000 LBS.
35	On tail boom fwd of station 772, paint black.	
36	Below LH cockpit window. Note: Date shown is date aircraft painted with MI L-C-46168 paint. Aircraft black.	
37	Both sides of Aircraft. Most forward letter (U -left side, Y - right side) to start at STA453.0, Top of Letters will be at WL 186.0. Letters to be 6 in. high lusterless black. Additional dimensions and spacing in accordance with Fig 8-2.	UNITED STATES ARMY

Figure 9-14. Exterior and Interior Markings, CH-54 (Sheet 7 of 7)



NOTE
 Interior surfaces, MIL-C-46168, interior
 aircraft gray, #36231.

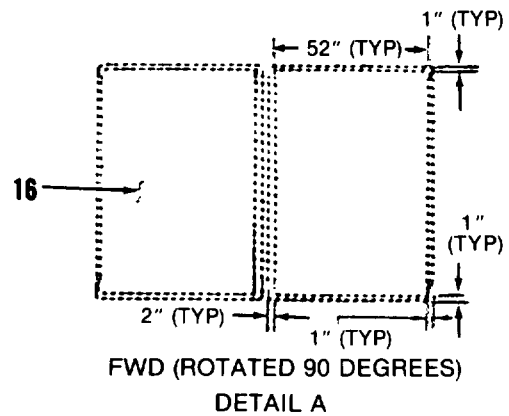
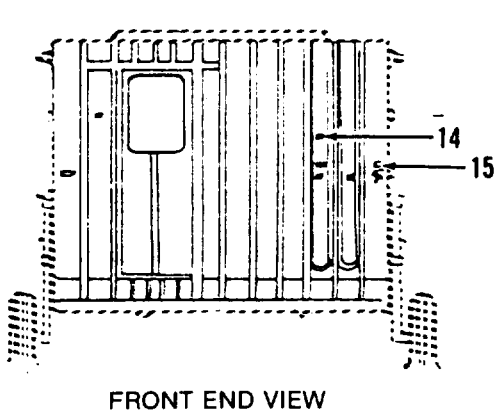
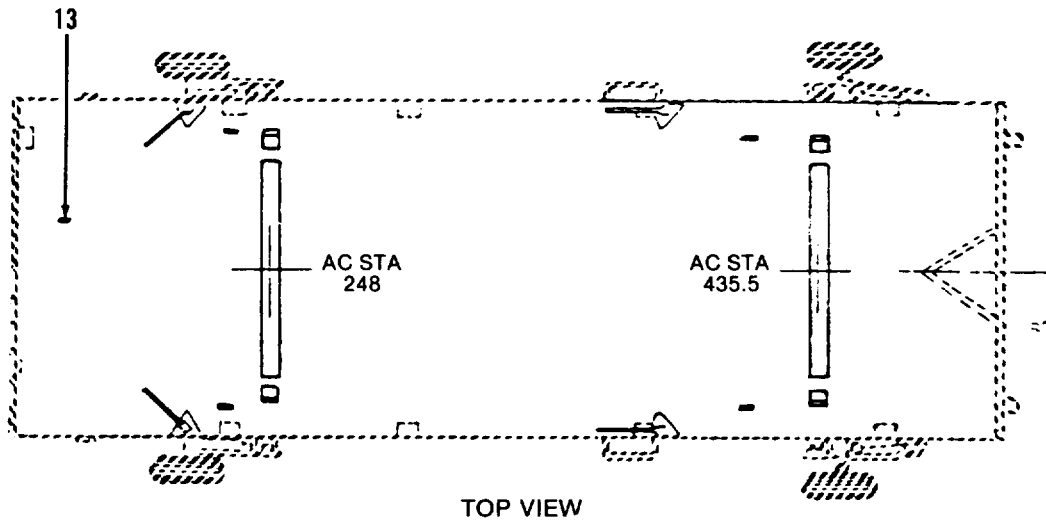


Figure 9-15. Interior Markings, CH-54 Universal Pod (Sheet 1 of 3)




CODE NO.	DIRECTIONS	WORDING								
1	Stencil interior of personnel doors adjacent to handles, left and right side, 1/2-in. MIL-C-46168, aircraft black, #37038 letters and black stripes 3/4 in. x 5 in.	<p>CLOSED  TO OPEN</p> <p>OPEN  PULL  TURN</p>								
2	Paint 2 in. band around inside periphery of personnel doors, MIL-C-46168, aircraft white, #37875.									
3	Stencil interior adjacent to landing gear oil reservoirs, stations 224, and 444, WL 120, left and right side, 1/2-in. black letters.	LDG GEAR HYD RESERVOIR 2 QTS CAPACITY MIL-H-5606								
4	Paint interior of emergency window frames aircraft white 4 places.									
5	Stencil 1/2-in. orange-yellow letters on black background above window, left and right side, 4 places.	EMERGENCY EXIT DITCHING USE ONLY PUSH OUT WINDOW								
6	Inside of fuselage between stations 324 and 344, WL 142, left and right side, 1/2-in. black letters.	HOWITZER WHEELS MUST BE STOWED OVER STA 304, STA 324 OR STA 344								
7	Left side of fuselage frame, WL 142, 8 places, 1/2-in. black letters.	<table border="0"> <tr> <td>STA 224</td> <td>STA 264</td> </tr> <tr> <td>STA 304</td> <td>STA 324</td> </tr> <tr> <td>STA 344</td> <td>STA 384</td> </tr> <tr> <td>STA 424</td> <td>STA 464</td> </tr> </table>	STA 224	STA 264	STA 304	STA 324	STA 344	STA 384	STA 424	STA 464
STA 224	STA 264									
STA 304	STA 324									
STA 344	STA 384									
STA 424	STA 464									
8	Left and right side of fuselage at stations 250, 312, 390, and 470, WL 122. Forward bulkhead at BL42, WL 132, 9 places, 1/2-in. black letters.	FIRST AID KIT								
9	Right side at station 456 and left side at station 232, WL 133, 1/2-in. MIL-C-46168, aircraft red, #31 136 letters on MIL-C-46168, aircraft white, #37875 background.	FIRE EXTINGUISHER								
10	Right side at station 219 and left side at station 469, WL 121, 1/2-in. orange-yellow letters on black background.	EMERGENCY AXE								

Figure 9-15. Interior Markings, CH-54 Universal Pod (Sheet 2 of 3)




CODE NO.	DIRECTIONS	WORDING
11	Left and right side near ramp door handles, black stripes 1 in. x 7 in. 1/2-in. black letters.	 <p>OPEN TO OPEN RAMP DOOR</p> <p>PUSH IN  TURN UP</p> <p>LOCKED</p>
12	Left and right side adjacent to ramp handles, WARNING, will be 1-in. red letters, all others 1/2-in. on white background.	WARNING BEFORE OPERATING RAMP RELEASE HANDLE STATION MAN OUTSIDE
13	Top of fuselage, right side of station 187, BL 17, 1/2-in. black letters.	ICS
14	Forward bulkhead at BL 32 and WL 125, 1/2-in. black letters.	DATA CASE
15	Forward bulkhead adjacent to handles, left and right side, 1/2-in. orange-yellow letters on black background.	<p>EMERGENCY RELEASE</p>  <p>PULL TURN</p>
16	Apply non-skid coating to inside surface of ramp. Paint black. (See Detail A)	

Figure 9-15. Interior Markings, CH-54 Universal Pod (Sheet 3 of 3)

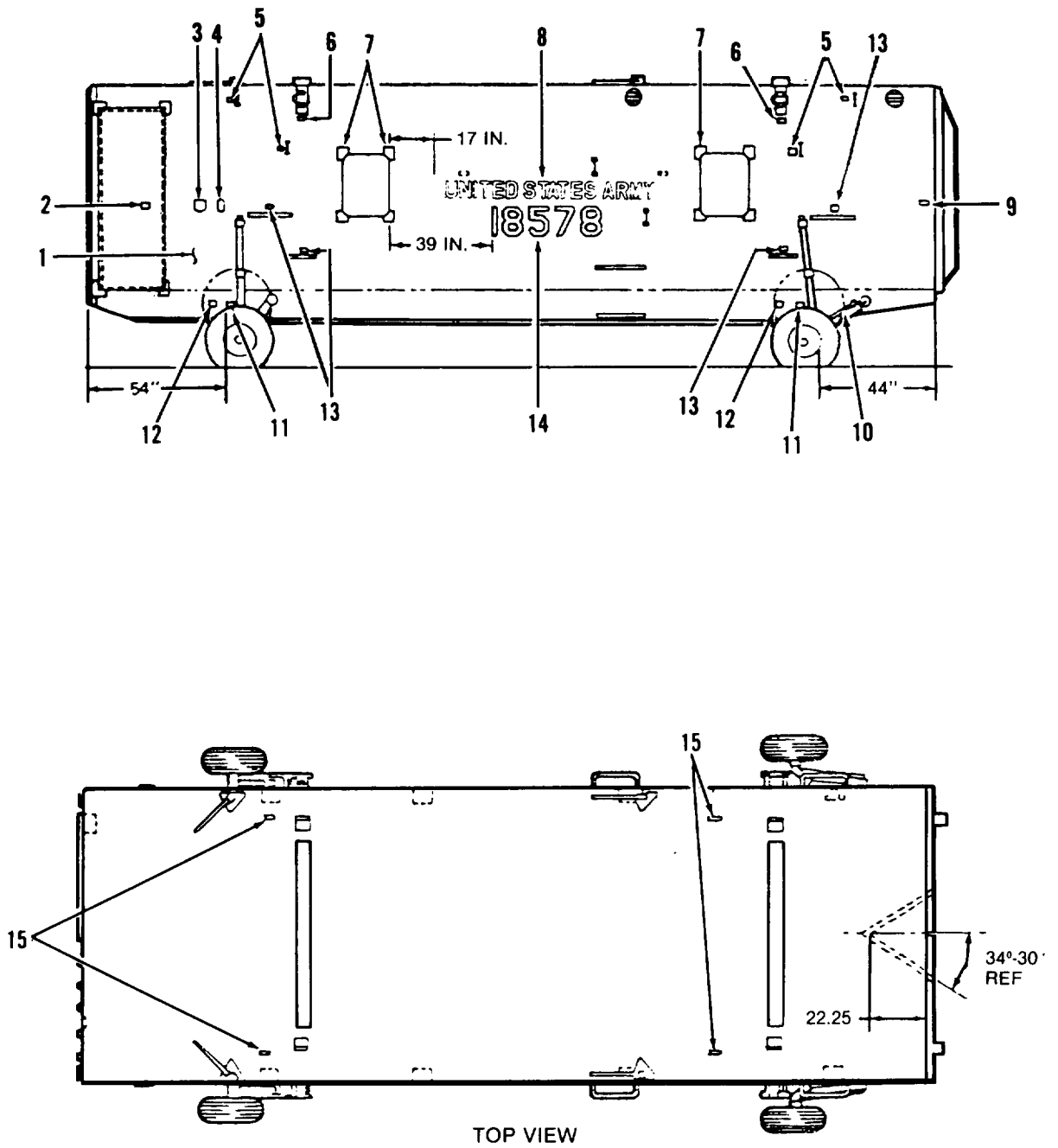


Figure 9-16. Exterior Markings, CH-54 Universal Pod (Sheet 1 of 4)

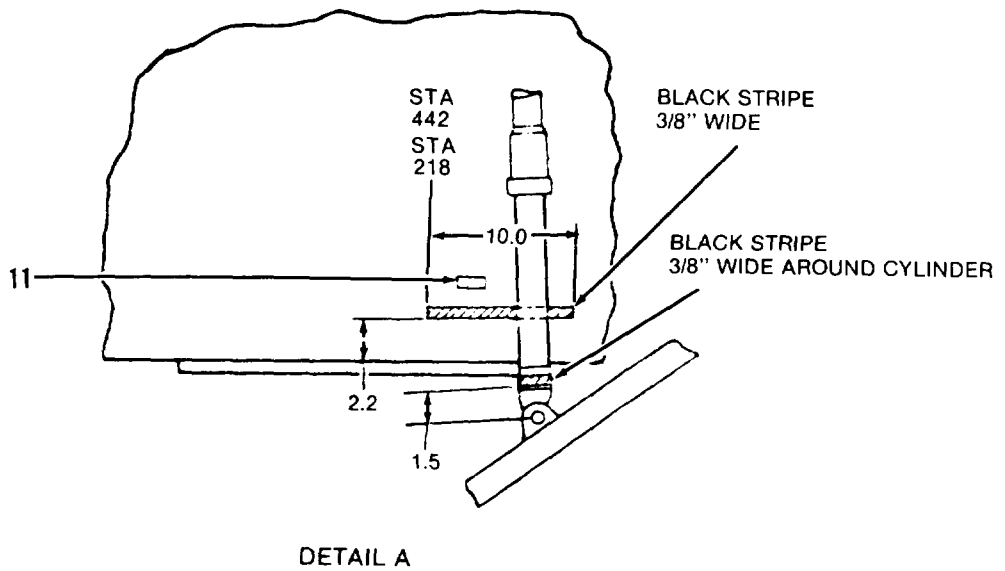
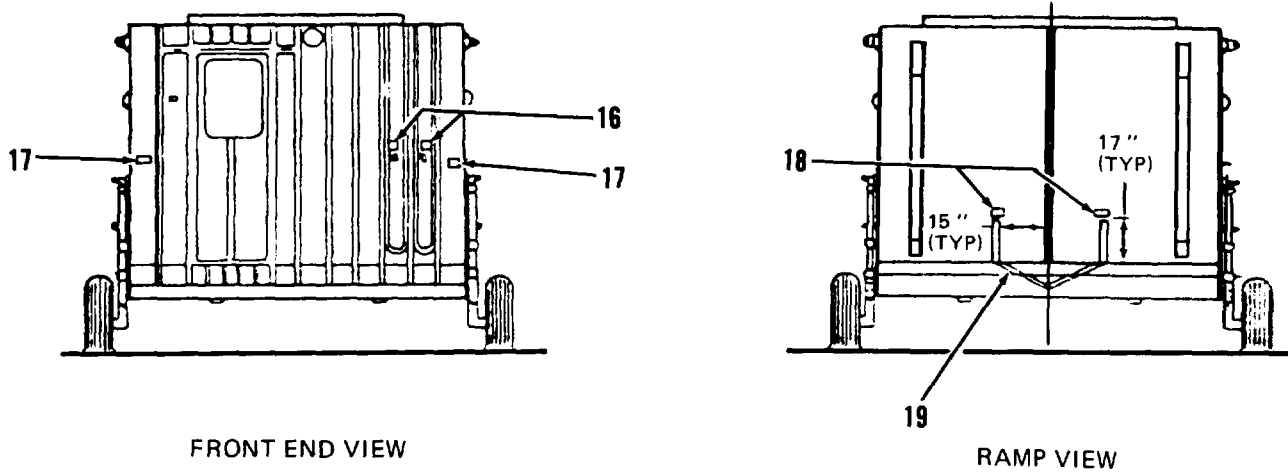


Figure 9-16. Exterior Markings, CH-54 Universal Pod (Sheet 2 of 4)


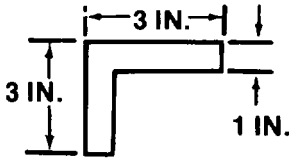
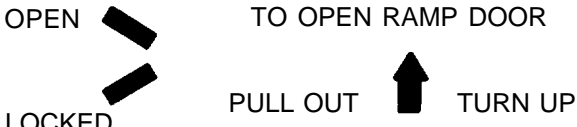
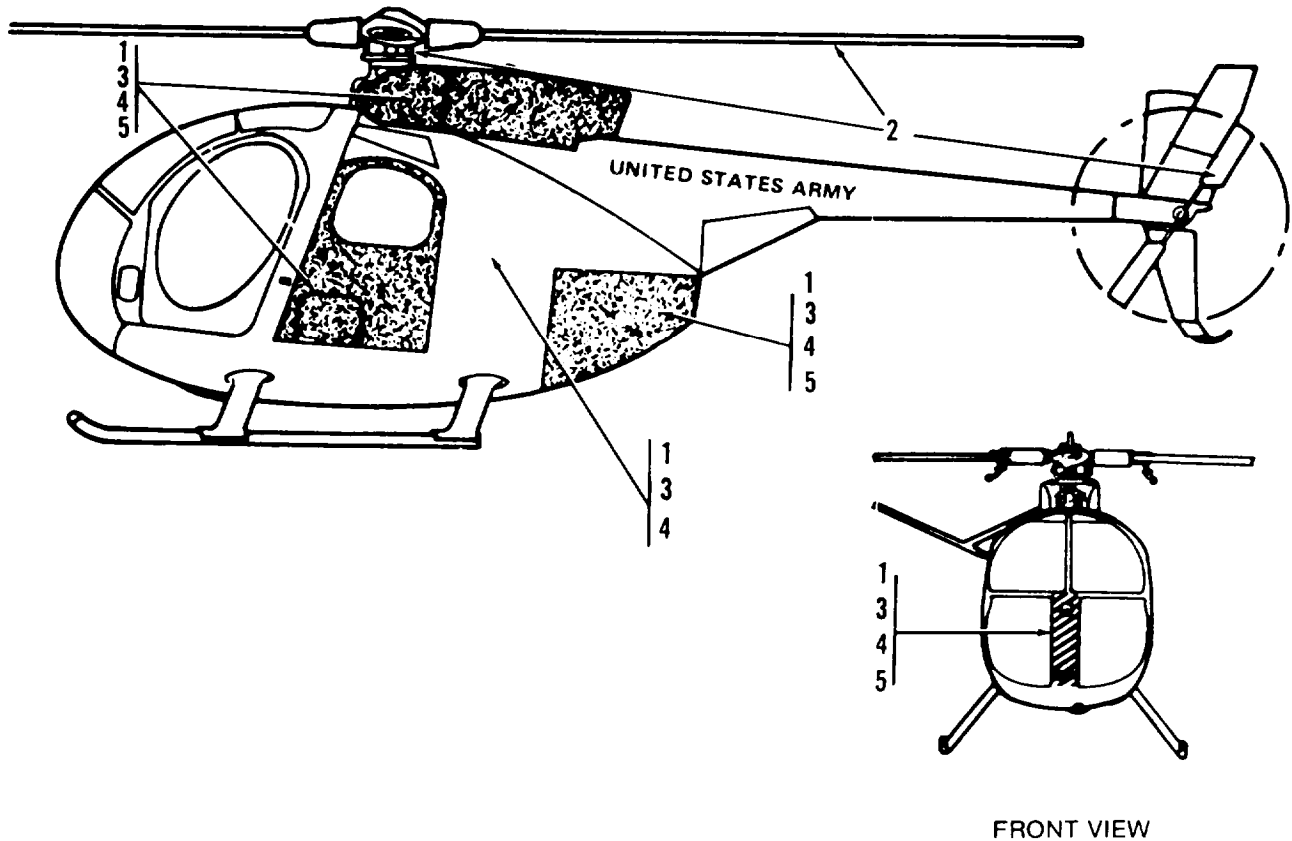
CODE NO.	DIRECTIONS	WORDING
1	Finish coat will be MIL-C-46168, aircraft green.	
2	Left and right side of personnel doors adjacent to handles, 1/2-in. MI L-C-46168 aircraft black, #37038, letters and stripes 3/4 in. x 5 in.	
3	Left fwd side of fuselage above external power door, station 210, WL 94, 1/2-in. black letters.	EXT POWER 115 VOLTS AC
4	Left fwd side of fuselage above external power door, station 216, WL 94, 1/2-in. black letters.	EXT POWER 28 VOLTS DC
5	Left and right side of fuselage adjacent to handles, 12 places, 1/2-in. black letters.	HAND HOLD
6	Left and right side of fuselage directly below pickup and mooring points, stations 248 and 435.5, WL 145, 4 places, 1-in. black letters.	POD PICKUP AND MOORING POINTS
7	Left and right side of fuselage paint 1 in. x 3 in. black stripes at each corner of personnel doors and emergency windows, 24 places.	
8	Both sides of Universal Pod. Most forward letter (U - left side, Y - right side) to start 17.0 in. aft of Fwd Emergency Window. Top of letters will beat WL 119. Letters to be 6 in. high lusterless black. Additional dimensions and spacing in accordance with Fig 8-2.	UNITED STATES ARMY
9	Left and right side of fuselage adjacent to door handles, 1/2-in. black letters and 1 in. x 7 in. black stripes.	
10	Left and right side of fuselage on landing gear steering rod, 1/2-in. black letters.	NO STEP

Figure 9-16. Exterior Markings, CH-54 Universal Pod (Sheet 3 of 4)

CODE NO.	DIRECTIONS	WORDING
11	Left and right side of fuselage near fwd and aft wheels, 4 places, 1/2-in. black letters. (See Detail A.)	ALIGN STRIPES BEFORE TOWING
12	Left and right side of fuselage near fwd and aft wheels, 4 places, 1/2-in. black letters.	TIRE PRESSURE 85-90 PSI
13	Left and right side of fuselage above each step, 12 places, 1/2-in. black letters.	STEP
14	Left and right side of fuselage 5 in. below code 8, and 39 in. from aft emergency exit window frame, 6-in. black numbers.	(Serial Number)
15	Top of fuselage pod between sway brace and support cover, BL 45, 4 places, 1/2-in. black letters.	ATTACHMENT FOR TROOP ← TRANSPORT ONLY → WEIGHT OF POD AND CONTENTS NOT TO EXCEED 14,400 LBS
16	Fwd end of fuselage adjacent to electric harness connector, 2 places, 1/2-in. black letters.	HARNESS ASSY
17	Left and right side of fwd bulkhead adjacent to handles, 1/2-in. black letters, arrow pointing outboard.	EMER REL PUSH TURN ➔
18	Left and right side of ramp door above code 19, 1-in. black letters.	CAUTION DO NOT TURN TOW BAR BEYOND STRIPE
19	Paint 2 -in. black stripes on exterior of ramp door as shown in drawing.	

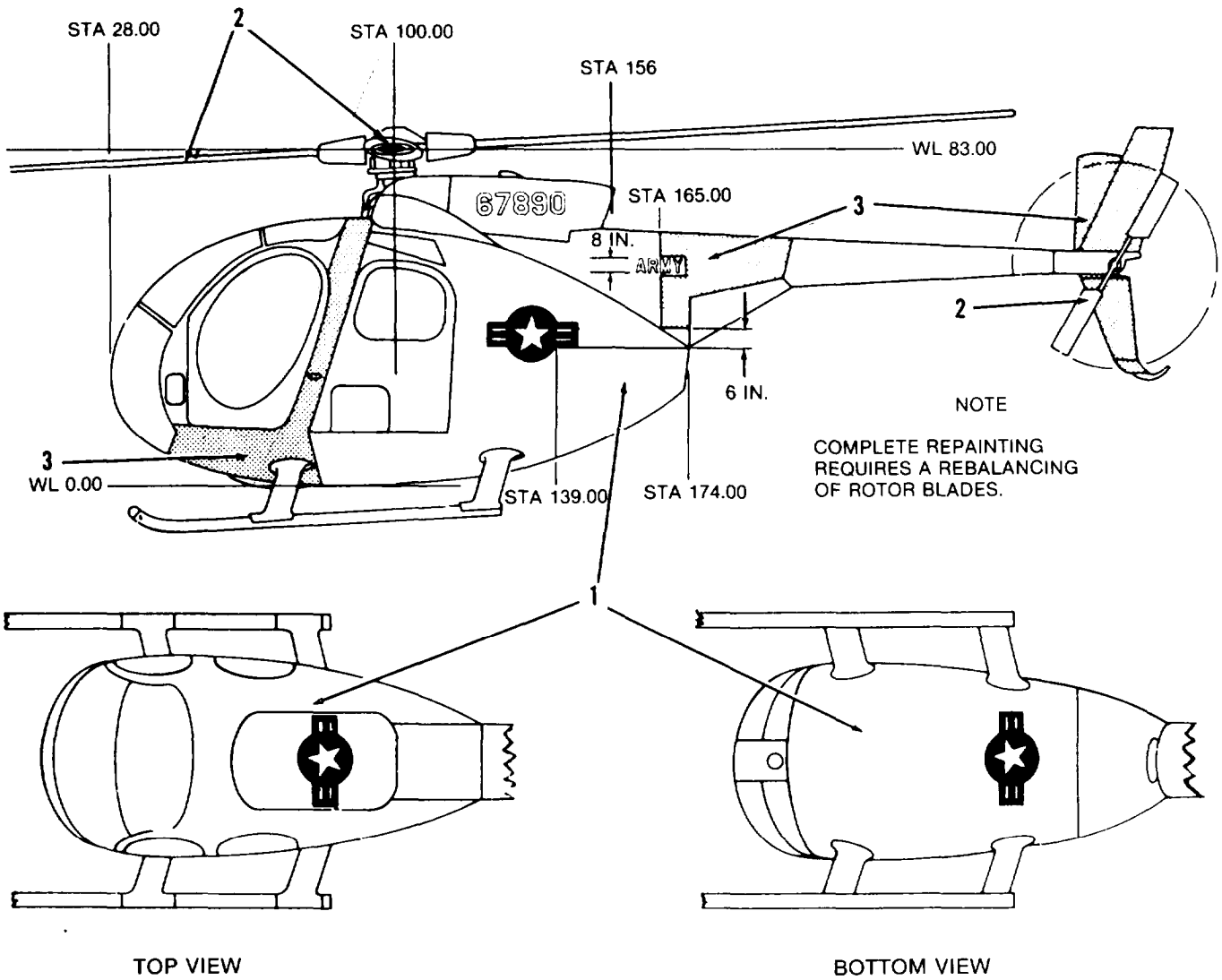
Figure 9-16, Exterior Markings, CH-54 Universal Pod (Sheet 4 of 4)

Section V. OH-6 ILLUSTRATIONS



1. MIL-C-46168, Aircraft Green (entire aircraft, except as noted).
2. MIL-C-46168, Aircraft Black.
3. MIL-C-46168, Dark Sand (entire aircraft or high conspicuous paint scheme when authorized, desert operations only). See Paragraph 5-11.
4. MIL1-C-46168, Aircraft White (entire aircraft or high conspicuous paint scheme when authorized, arctic operations only). See Paragraph 5-11.
5. MIL-P-21600, Fluorescent Red-Orange. ANA #633 (training aircraft-high visibility, only where authorized).

Figure 9-17. Tactical Paint Scheme, OH-6



1. MI L-C-46168, aircraft green (entire aircraft, except where noted).
2. MIL-C-46168, aircraft black.
3. MIL-P-21600, fluorescent red-orange, ANA #633 (shaded areas only).

Figure 9-18. Non-Tactical Arctic/Desert Paint Scheme, OH-6

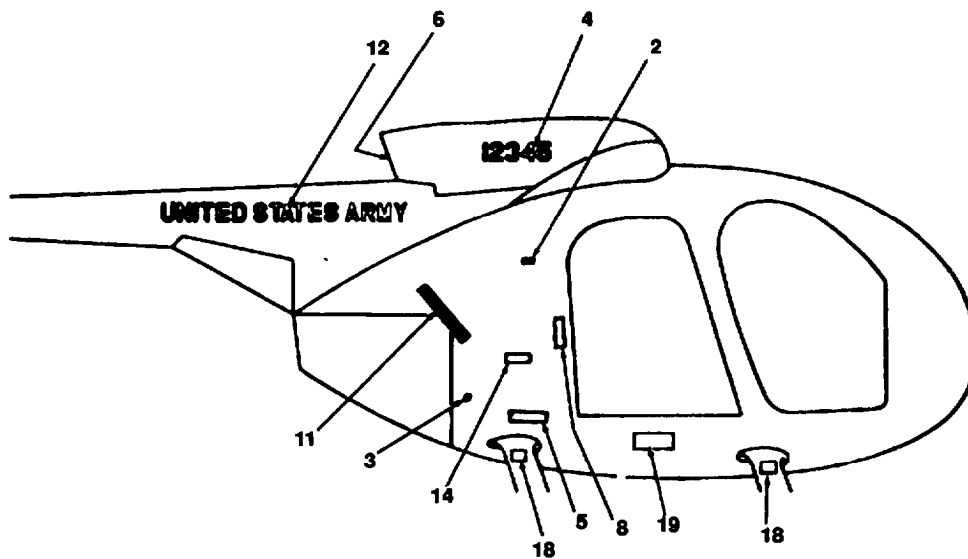
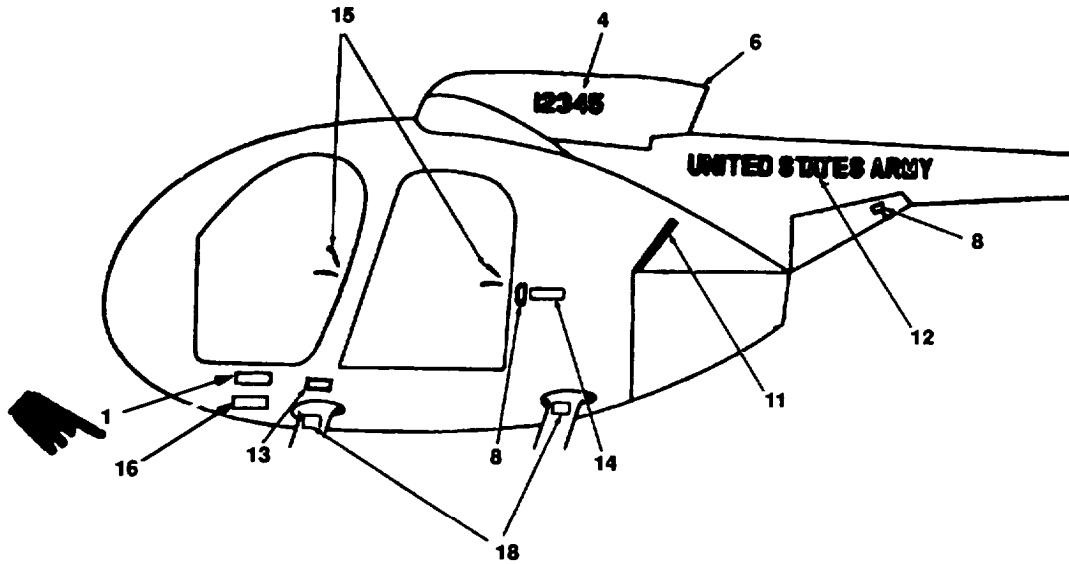
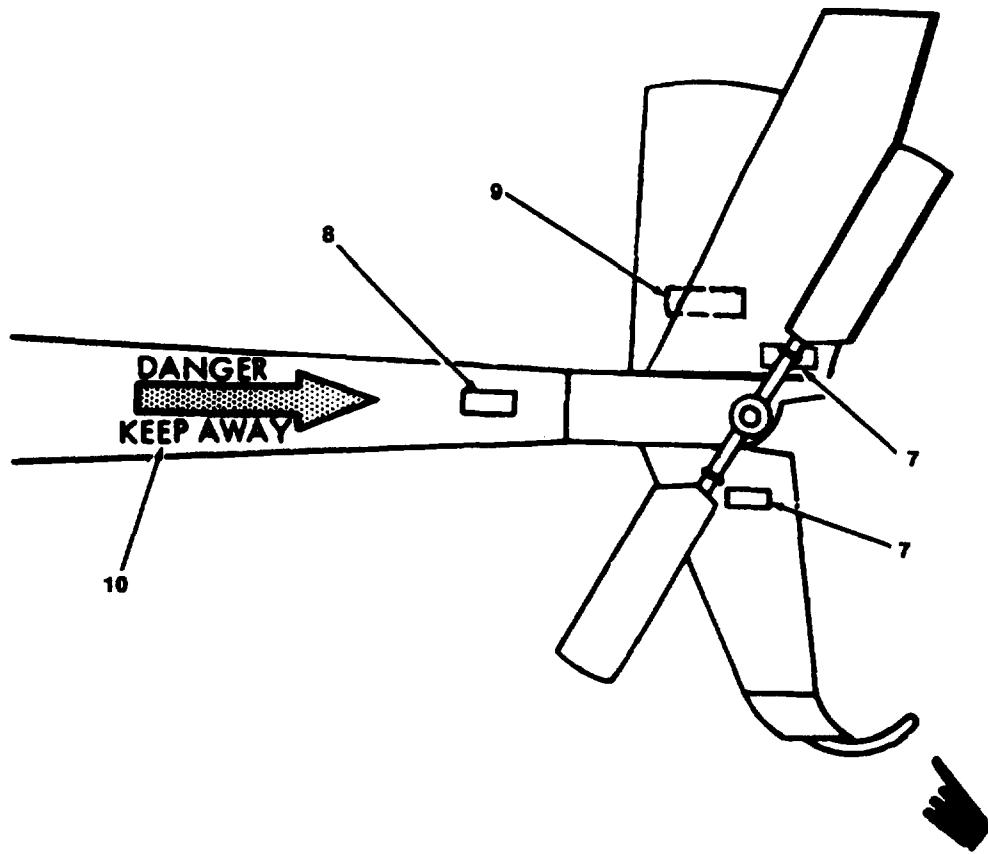


Figure 9-19. Exterior Markings, OH-6 (Sheet 1 of 5).



NOTE:
MAIN ROTOR AND TAIL ROTOR BLADES
WILL BE PAINTED IN ACCORDANCE
WITH CHAPTER 6

Figure 9-19. Exterior Makings, OH-6 (Sheet 2 of 5).


CODE NO.	DIRECTIONS	WORDING
1.	Left side fuseladage below cockpit entrance 1/2-in. MIL-C4618 aircraft black No. 37038 letters.	U.S. ARMY OH-6 U.S.A. SERIAL NO. (Insert Serial No.) SERVICE THIS AIRCRAFT WITH MIL-T-5624, GRADE JP-4 AVIATION FUEL. IF NOT APPLICABLE REFER TO TB 55-9150-200-24 FOR ALTERNATE/EMERGENCY FUEL.
2	Right side fuselage above oil filler cap 1/2-in. black letters	OIL MIL-L-23699 ABOVE -25°F, MIL-L-7808 BELOW -25°F.
3	Paint a black ground symbol, shade 37038, dimensions per MS 27606-2	
4	Left and right side of fairing. Centrally located 6-in. black letters.	(Radio Call Number)
5	Insert fuel capacity for type fuel tank installed 1/2 in. black letters.	CAP. U.S. GAL. USE MIL-T-5624 GRADE JP-4
6	Aft end of static port circular 3/8-in. broken band, inside diameter 2 1/4-in., aircraft black.	
7.	Locate on upper and lower vertical stabilizers, both sides, 1/2-in. aircraft black letters, 4 places.	NO PUSH
8	Left and right sides of tail boom and aft of both cargo doors 1/2-in. black letters.	PUSH HERE
9.	Top and bottom of horizontal stabilizer 1/2-in. black letters.	NO PUSH

Figure 9-19. Exterior Markings, OH-4 (Sheet 3 of 5)

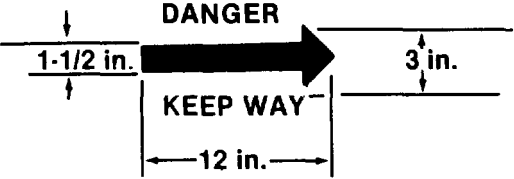
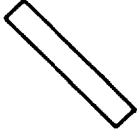
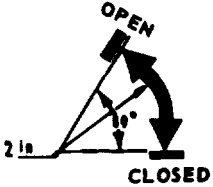
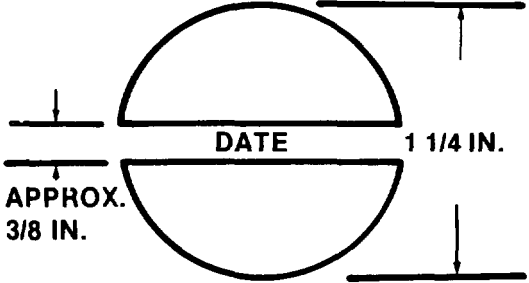
CODE NO.	DIRECTIONS	WORDING
10	Left and right side of tail boom 1-1/2x 12 in. aircraft black arrow. 1-in. black letters. Arrow points aft.	
11	Left and right side of fuselage. Black turbine wheel warning line. 1 in. wide, 16 in. long. Bottom of line located 1 in. above WL 34.5. Runs diagonally from Sta. 142.5 to Sta 150.5.	
12	Both sides of Aircraft. Most forward letter (U - left side, Y - right side) to start at STA. 144. Top of letters are at WL 57.0 in. and parallel to center line of tailboom. Letters to be 6 in. high lusterless black. Additional dimensions and spacing in accordance with Fig. 8-2.	UNITED STATES ARMY
13	Left side of fuselage below cockpit door, 3/4-in. aircraft black letters.	<p style="text-align: center;">BATTERY LOCATED ← INSIDE</p>
14	On both sides of fuselage above navigation lights, 1/2-in. black letters.	NO STEP
15	Arrow indicating direction to turn each door handle. Arrow black (4 places).	
16	Left side of fuselage below code 1. Aircraft black. Note: Date shown is date aircraft painted with MIL-C-46168 paint.	
17	For tactical aircraft, authorized placement of unit insignia is on either or both sides of engine cowl.	

Figure 9-19. Exterior Markings, OH-6 (Sheet 4 of 5)

CODE NO	DIRECTIONS	WORDING
18	Landing gear fairing near top and bottom (8 places), 1-in. aircraft black letters.	NO STEP
19	Aircraft with ballistic and crash resistant fuel system installed. Locate above pressure fuel fitting, top line 3/4-in. and bottom line 1/2-in. aircraft black letters.	PRESSURE FUELING ONLY MIL-T-5624, JP-4.

Figure 9-19. Exterior Markings, OH-6 (Sheet 5 of 5)

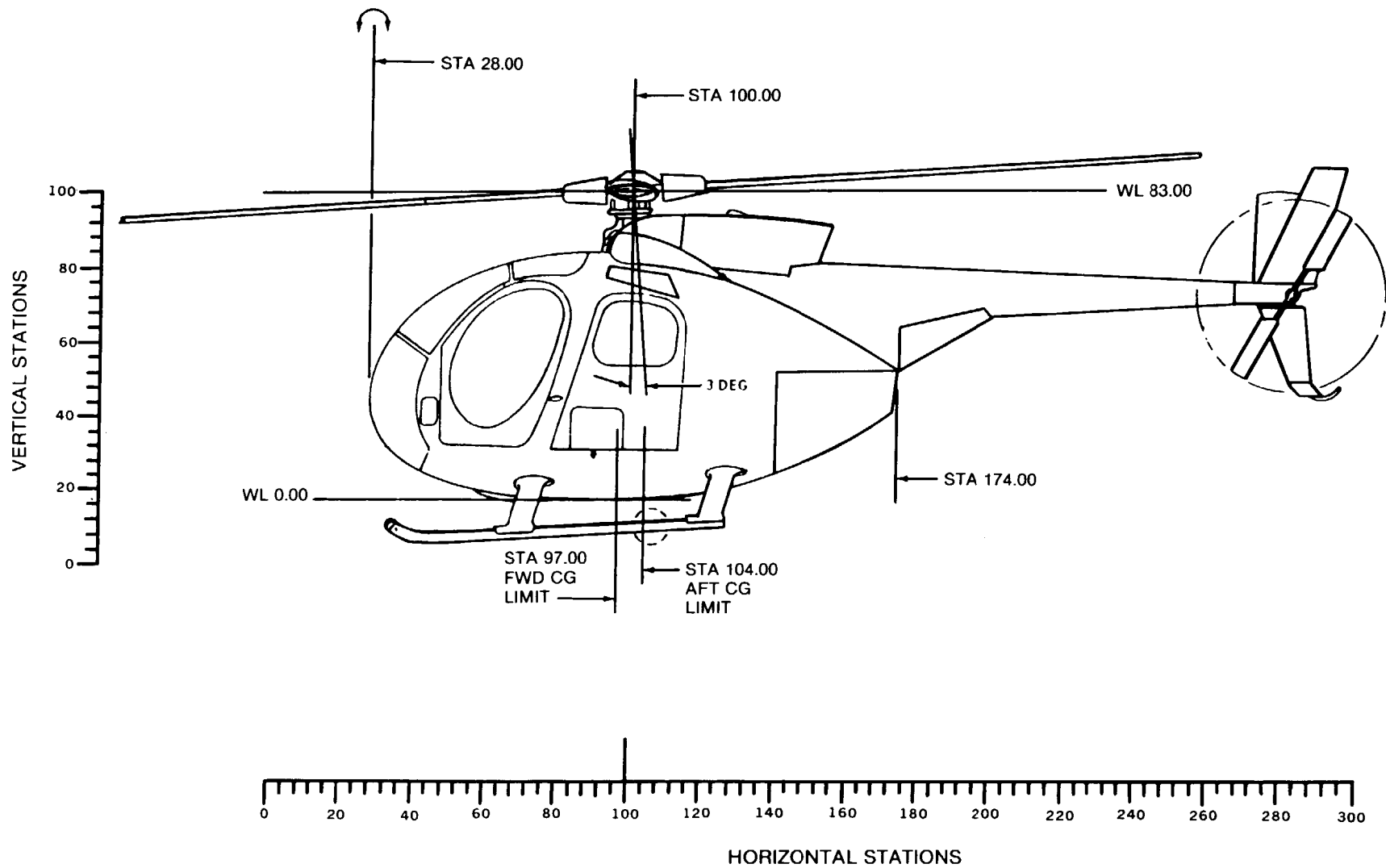
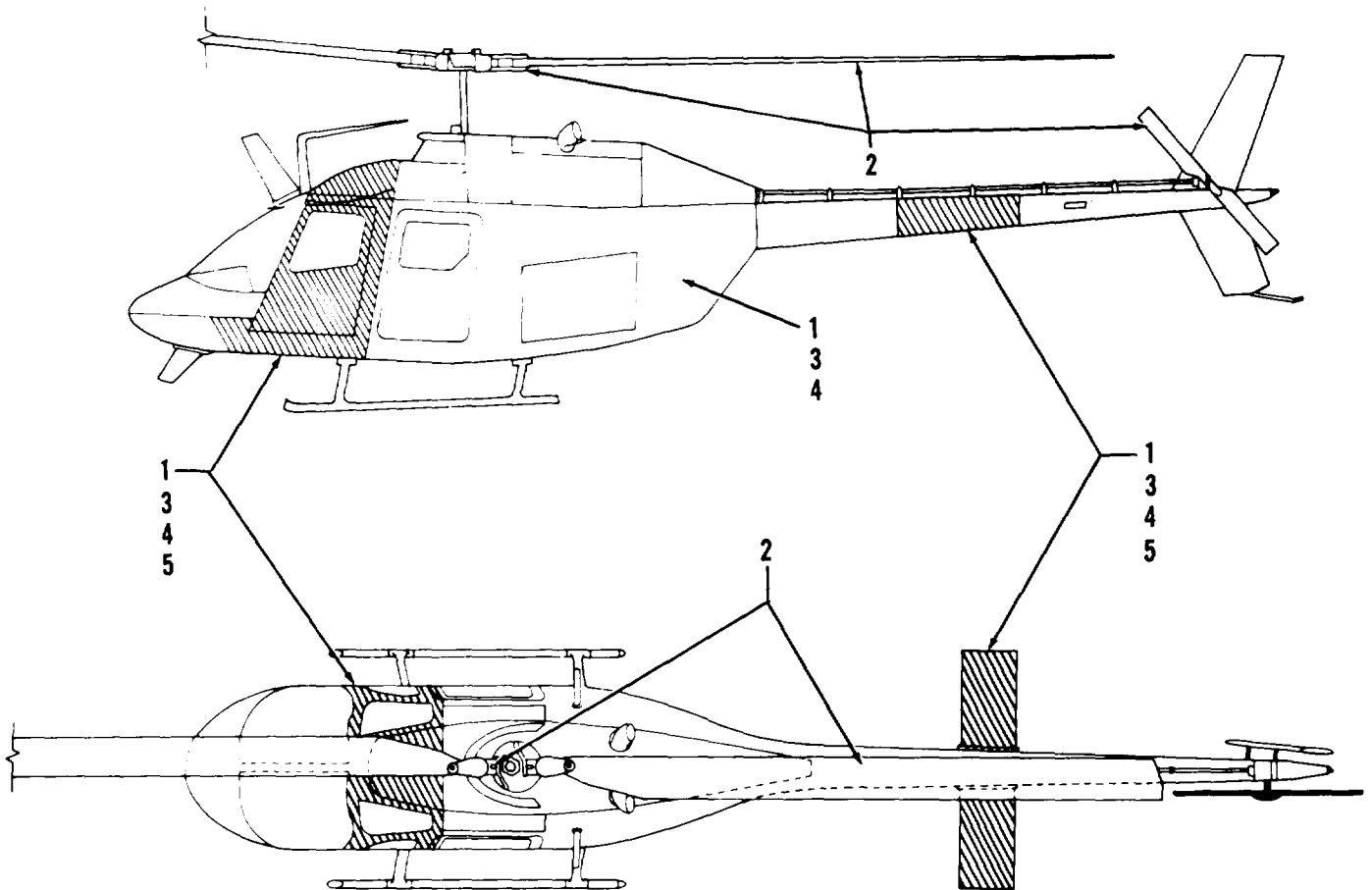


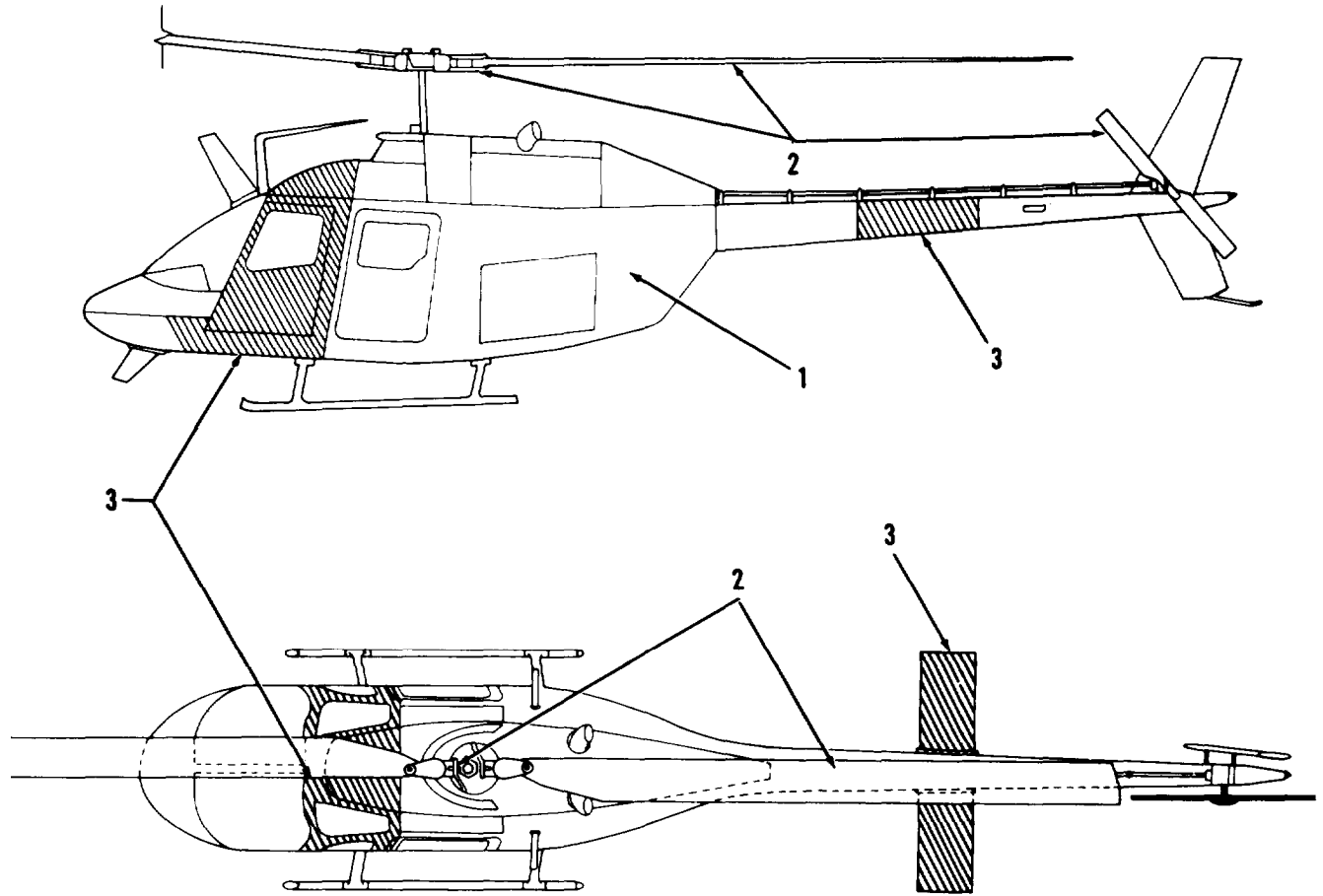
Figure 9-20. Station Diagram, OH-6

Section VI. OH-58 ILLUSTRATIONS



1. MIL-C-46168, Aircraft Green (entire aircraft, except as noted).
2. MIL-C-46168, Aircraft Black.
3. MIL-C-46168, Dark Sand (entire aircraft or high conspicuous paint scheme when authorized, desert operations only). See Paragraph 5-11.
4. MIL-C-46168, Aircraft White (entire aircraft or high conspicuous paint scheme when authorized, arctic operations only). See Paragraph 5-11.
5. MIL-P-21600, Fluorescent Red-Orange. ANA #633 (training aircraft-high visibility, only where authorized).

Figure 9-21. Tactical Paint Scheme, OH-58



1. MIL-C-46168, aircraft green (entire aircraft, except as noted).
2. MIL-C-46168, aircraft black.
3. MIL-P-21600, fluorescent red-orange, ANA #633 (shaded areas only).

Figure 9-22. Non-Tactical Arctic/Desert Paint Scheme, OH-58

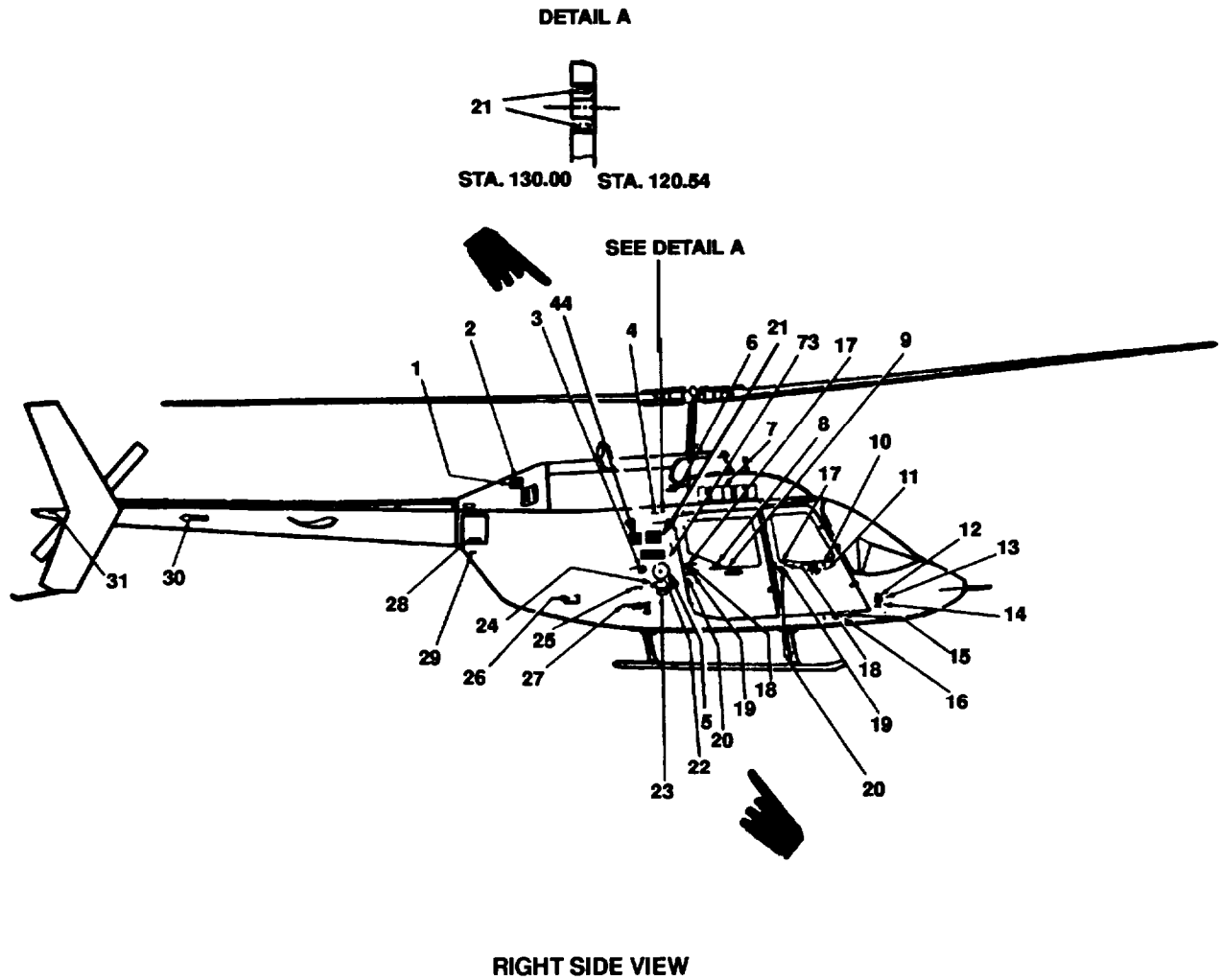
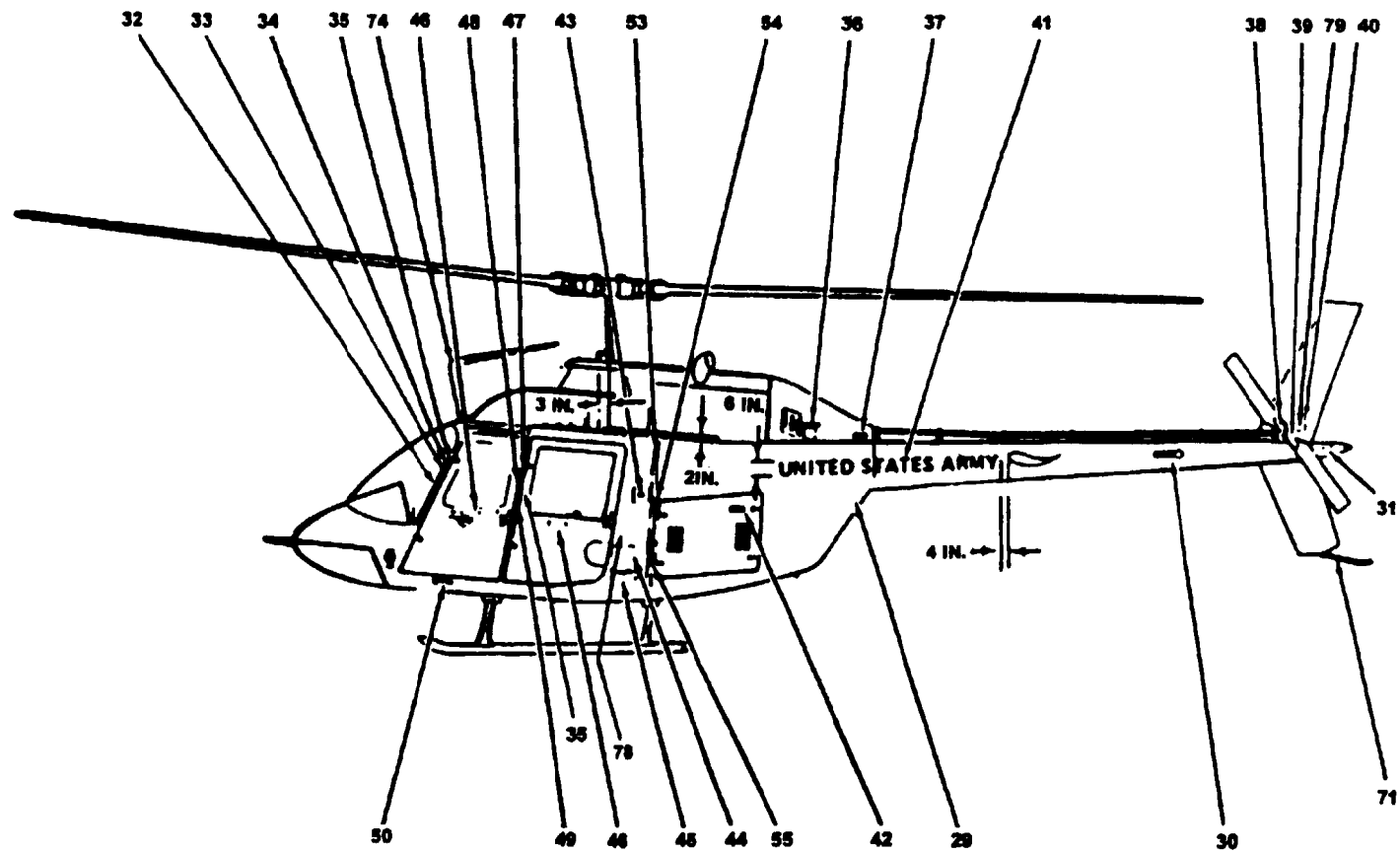
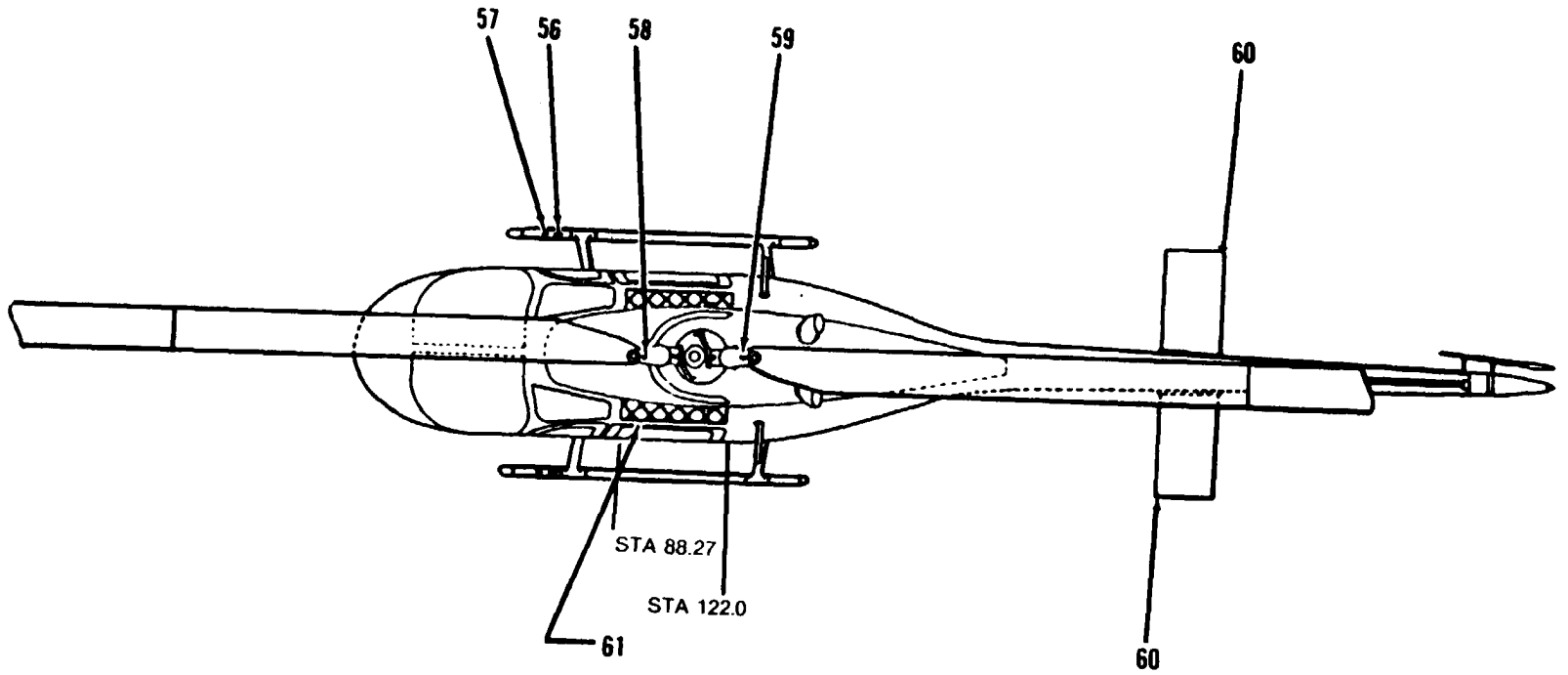


Figure 9-23. Interior and Exterior Markings, OH-58 (Sheet 1 of 13).



H5017816

Figure 9-23. Interior and Exterior Markings, OH-58 (Sheet 2 of 13).



■ Figure 9-23. Interior and Exterior Markings, OH-58 (Sheet 3 of 13).

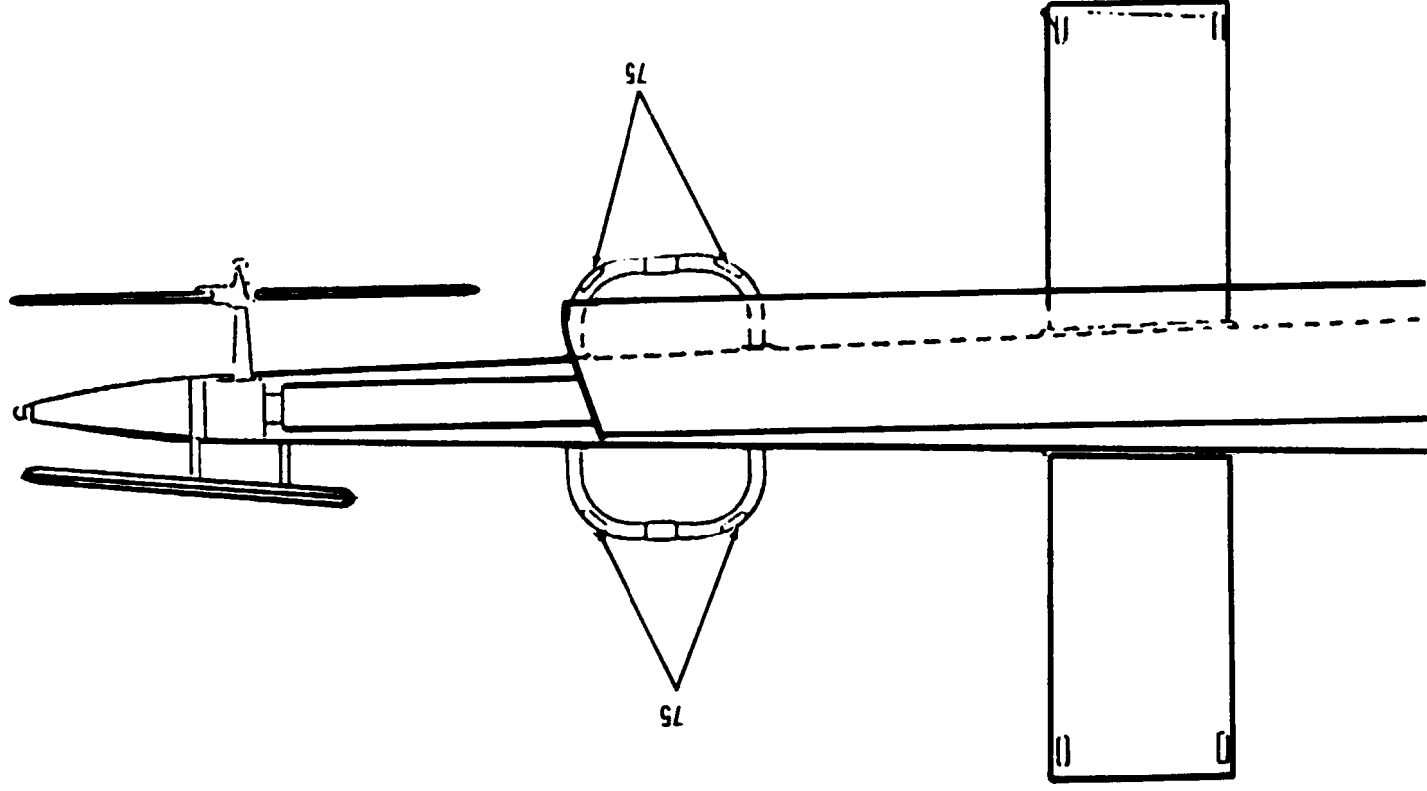
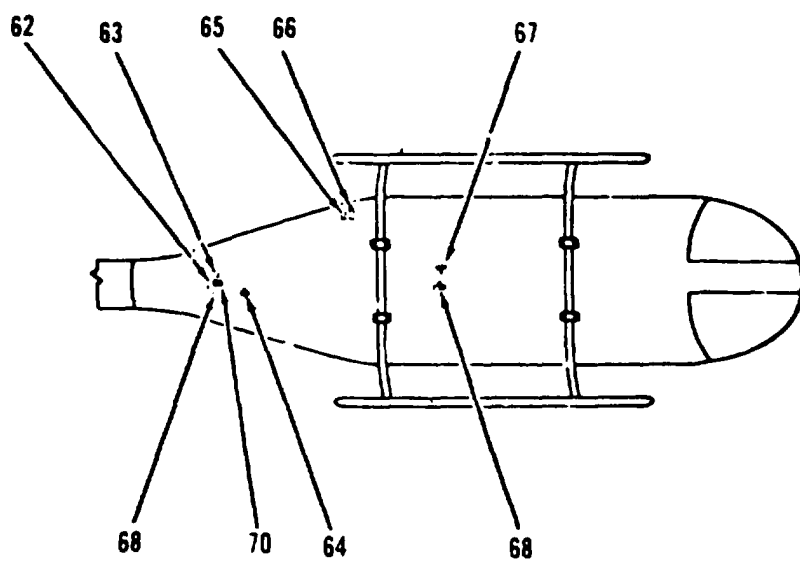
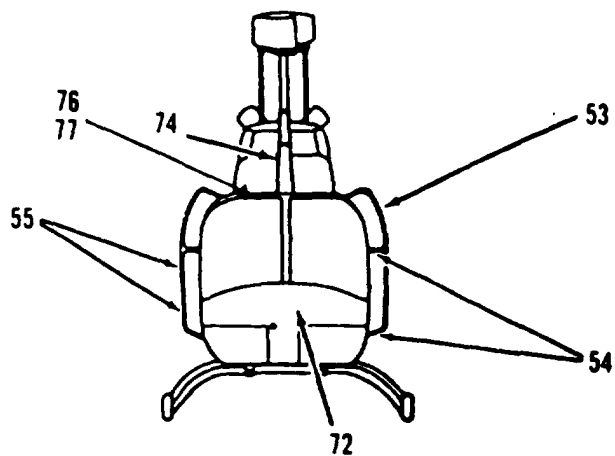


Figure 9-23. Interior and Exterior Markings, OH-58 (Sheet 4 of 13).



BOTTOM VIEW



FRONT VIEW

Figure 9-23. Interior and Exterior Markings, OH-58 (Sheet 5 of 13).



CODE NO.	DIRECTIONS	WORDING
1	Right side, aft of engine compartment on aft fairing. 5/8-in. MIL-C-46168 aircraft black, #37038 letters.	ENGINE OIL ABOVE 25°F MIL-L-23699 BELOW 25°F MIL-L-7808
2	Right side, above Code 1. 5/8-in. aircraft black letters.	ENGINE OIL FILLER CAP ACCESS
3	Paint a black ground symbol, shade 37038, dimensions per MIL-C-83413/9-2.	
4	Below forward edge of engine cowl side panel, right side. 5/8-in. aircraft black letters.	CABIN ROOF DRAIN
5	Paint fuel filler cap same color as the fuselage. Paint a 1 inch wide ring around filler aircraft black. 1 inch ring to be 2 inch from cap center.	
6	Right side below right air intake screen. 5/8-in. aircraft black letters, OH-58A, C and D. OH-58D(I) see NOTE in wording.	TRANSMISSION OIL LEVEL ACCESS ABOVE - 25°F MIL-L-23699 BELOW - 25°F MIL-L-7808 NOTE TRANSMISSION OIL LEVEL ACCESS ABOVE - 40°F DOD-L-85734 BELOW - 40°F MIL-L-7808
7	Locate on both sides fwd fairing, 2 1/2 in. above roof skin and 3 in. fwd of mast center-line. 6 in. high and 4 in. wide aircraft black letters with 1 in. spacing between letters.	(RADIO CALL NUMBER)
8	Inside both passenger doors. 5/8-in. MIL-C-46168, aircraft white #37875 letters.	OPEN
9	Inside both passenger doors. 5/8-in. aircraft white letters.	CLOSED
10	Inside of both crew doors. 5/8-in. aircraft white letters.	OPEN
11	Inside of both crew doors. 5/8-in. aircraft white letters.	CLOSED
12	Above static ports, both sides of fuselage. 3/8-in. aircraft black letters.	DO NOT PLUG OR DEFORM HOLES

Figure 9-23. Interior and Exterior Markings, OG-58 (Sheet 6 of 13)

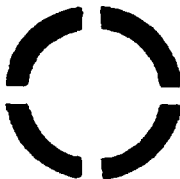


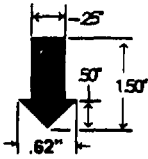
CODE NO.	DIRECTIONS	WORDING
13	Both side of helicopters, a 5/8 inch wide band with a 2-5/8 inch outside diameter, aircraft black.	
14	Below static port both sides. 3/8-in. aircraft black letters.	STATIC PORT
15	Both sides of aircraft fwd of sta 55.16 on lower side, aircraft black.	JACK POINT 
16	Both sides of aircraft fwd of sta 55.16 near jack points aircraft black.	MOOR 
17	Exterior on fwd and aft doom, above door handles, both sides of fuselage. 1-3/8 in. aircraft black letters.	EXIT RELEASE
18	Exterior on fwd and aft doors, below door handles, both sides of fuselage. 1-3/8 in. aircraft black letters.	TURN
19	Exterior on fwd and aft doors, below door handles both sides of fuselage. 1-3/8 in. aircraft black letters.	PULL
20	Exterior on fwd and aft doom, below door handles, both sides of fuselage. Aircraft black letters.	
21	On back of panel, right side of aircraft above fuel filler. 5/8-in. orange-yellow letters.	STRUCTURAL PANEL REQUIRED FOR GROUND RUN AND FLIGHT
22	On right side of aircraft below fuel filler cap. 5/8 in. aircraft black letters.	CAP .71.5 U.S. GAL USE ML-T-5624 GRADE JP-4 or JP-5 If not available refer to TB 55-9150-200-24 for alternate fuel

Figure 9-23. Interior and Exterior Markings, OH-58 (Sheet 7 of 13)


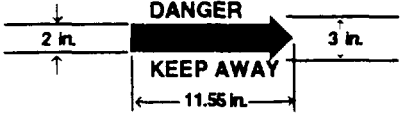
CODE NO.	DIRECTIONS	WORDING
23	On right side of aircraft below fuel filler cap. 1/4-in. aircraft black letters.	FOR OPERATING TEMPERATURES BELOW 40°FO.A.T., FUEL USED MUST CONTAIN PFA 55MB ADDITIVE. CONCENTRATION TO BE .06% - .15% BY VOLUME
24	On right side of aircraft below and aft of fuel filler cap. NATO refueling symbol aircraft black.	 <p>NATO CODE NO. MAX FILLING PRESSURE 125 PSI 8.8 Kg/cm2</p>
25	Right side of aircraft aft and below fuel filler, above external power receptacle. 5/8 in. aircraft black letters.	BATTERY VENT
26	Right side of aircraft on external power door. 1/2 in. aircraft black letters.	EXTERNAL POWER
27	AFT of external Power Receptacle.	
28	Located on interior and exterior of tail boom inspection plate. 5/8-in. aircraft black letters.	STRUCTURAL PANEL REQUIRED GROUND RUN AND FLIGHT
29	Both sides of aircraft fwd of tail boom on intermediate section. 5/8-in. aircraft black letters.	NO PUSH
30	OH-58A. On both sides of tail boom, centerline 19 in. aft of stabilizer. OH- 58C. 15-in. aft of stabilizer, aircraft black letters and arrows.	
31	Both sides of tail cone, 5/8 inch aircraft black letters.	NO PUSH
32	Locate on inside door post in two places both sides of aircraft. 1-3/8 in. orange-yellow letters.	EMERGENCY RELEASE
33	Below jettison handles, both sides. Inside on door posts, 1-in. aircraft white letters.	PULL

Figure 9-23. Interior and Exterior Markings, OH-58 (Sheet 8 of 13)

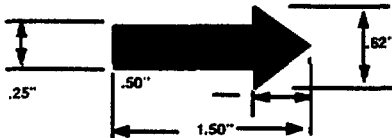


CODE NO.	DIRECTIONS	WORDING
34	Below jettison handles on pilot and copilot door posts. Aircraft white arrows pointing aft.	
35	Paint both jettison handles inside of aircraft with 1/8 inch wide alternate orange-yellow and black stripes.	
36	Left side of aircraft, aft of air louvers, on aft fairing. 5/8 in. aircraft black letters.	OIL TANK DRAIN ACCESS
37	Aft end of aft fairing, both sides. 5/8 in. aircraft black letters.	CAUTION DISCONNECT ELECTRICAL WIRING BEFORE REMOVING TAIL BOOM
38	0.30 in. diameter dot on one end of tail rotor yoke, corresponding end of crosshead and corresponding pitch link assembly. Paint MIL-C-46168 aircraft red, #31136.	
39	0.30 in. diameter dot on one end of tail rotor yoke, corresponding end of crosshead and corresponding pitch link assembly. Paint MIL-C-46168 aircraft white, #37875.	
40	Left side of vertical fin, adjacent to tail rotor gear box. 5/8-in. aircraft black letters, 0.38 in. space between lines, OH-58A, C and D. OH-58D(I) see NOTE in wording.	SERVICE GEAR BOX MIL-L-23699 ABOVE - 25°F MIL-L-7808 BELOW - 25°F NOTE ABOVE - 40°F DOD-L-85734 BELOW - 40°F MIL-L-7808
41	Both sides of Tail Boom, most AFT letter (Y-left side U-right side) to be 4.0 inch forward of stabilizer. Letters centered on center line of tail boom. Letters to be 6 in. high aircraft black #37038. Additional dimensions and spacing in accordance with Fig. 8-2.	UNITED STATES ARMY
42	Left side of aircraft, upper aft corner of avionics compartment door. 5/8-in. aircraft black letters.	BATTERY ACCESS
43	Left side of aircraft, on small door forward of the RF antenna and above the Avionics compartment door. 5/8 inch aircraft black letters.	STEP

Figure 9-23. Interior and Exterior Markings, OH-58 (Sheet 9 of 13)


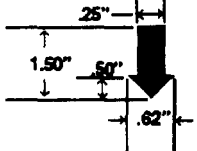
CODE NO.	DIRECTIONS	WORDING
44	Left side of aircraft aft of passenger door. First two lines 1-in. aircraft black letters. Remainder 1/2-in. letters. Note: Transfer data to right side of helicopter above the fuel filler cap when MWO 55-1520-228-50-53, ATS, has been applied	U.S. ARMY OH-58A U.S.A. SERIAL NO. (Insert serial no.) Service this aircraft with MIL-T-5624 Grade JP-4 aviation fuel
45	Left side of aircraft lower fuselage, fwd of antenna. 1/2-in. aircraft black letters.	IF NOT AVAILABLE REFER TO TB55-9150-200-24 FOR ALTERNATE FUEL
46	Interior, center on crew and passenger doors. 1-in. orange-yellow letters.	EMERGENCY EXIT
47	Interior of aircraft on passenger door post below upper hinges. Paint aircraft white arrows pointing fwd.	
48	Interior of aircraft on passenger door posts, below upper hinges. 5/8 inch aircraft white arrow pointing fwd.	PUSH
49	Interior of aircraft on passenger door posts, below upper hinges. Tops of letters pointing forward, 1-3/8-in. orange-yellow letters.	EMERGENCY RELEASE
50	Lower left and right sides of aircraft below crew doors. Aircraft black arrows pointing down at jack points.	
51		
52		

Figure 9-23. Interior and Exterior Markings, OH-58 (Sheet 10 of 13)

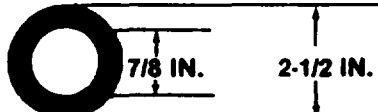
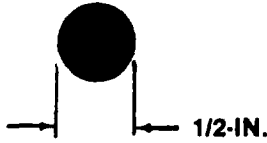
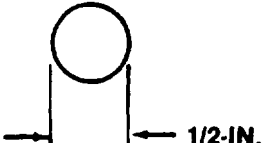
CODE NO.	DIRECTIONS	WORDING
53	Outside surface of left and right antennas. To be read from fwd side of antennas. 5/8-in. letters. MIL-C-46168, olive drab, #34037 letters on black background. MIL-C-46168, Black #37038 letters on aircraft green background.	NO HAND HOLD
54	Center and lower flat areas of left and right antennas. To be read from fwd side of aircraft. 5/8-in. MIL-C46168, olive drab #34037 letters in black background. MIL-C-46168, black #37038 letters on aircraft green background.	NO STEP
55	Center and lower outboard surface of left and right antennas. To be read from fwd side of aircraft 5/8-in. letters. MIL-C-46168 olive drab #34037 letters on black background. MIL-C-46168, black #37038 letters on aircraft green background.	NO PUSH
56	Top side of both landing skids above tow rings. Aircraft black.	
57	Top side of both landing skids above tow rings. 5/8-in. aircraft black letters	TOW
58	Upper and lower surfaces of main rotor grip and attaching linkage for each grip. 1/2-in. aircraft red dots.	
59	Upper and lower surfaces of main rotor grip and attaching linkage for each grip. 1/2-in. aircraft white dots.	

Figure 9-23. Interior and Exterior Markings, OH-58 (Sheet 11 of 13)



CODE NO.	DIRECTIONS	WORDING
60	Leading and trailing edge of stabilizer, both sides 5/8 in aircraft black letters. OH-58C (VOR antenna, right and left side, 4 places). 5/8-in. aircraft black letters.	NO PUSH
61	Apply walkway coating MIL-W-5044, Type II, both sides of aircraft between skin splices at sta 88.27 to 122.0. Paint to match existing color scheme.	
6 2	Underside of fuselage, on centerline, aft of jack point 5/8-in. aircraft black letters.	JACK POINT
63	Underside of fuselage, right of centerline, left of jack point. Aircraft black.	
64	Underside of fuselage, left of centerline, fwd of jack point. 5/8-in. aircraft black letters.	ENGINE OIL TANK DRAIN
65	Underside of fuselage, right side aft of aft cross tube. 5/8-in. aircraft black letters.	ENGINE DECK DRAIN
6 6	Underside of fuselage, right side aft of aft cross tube. 5/8-in. aircraft black letters.	FUEL CELL VENT
67	Underside of fuselage. Right side of centerline, between cross tubes. 5/8-in. aircraft black letters.	PUMP SEAL DRAIN
68	Underside of fuselage. Left of centerline, between cross tubes. 5/8-in. aircraft black letters.	DRAIN
69	Underside of fuselage. Left of centerline and jack point. Aircraft black.	
70	Underside of fuselage, fwd of jack point along centerline, 5/8-in. aircraft black letters.	MOOR
71	Non-tactical aircraft only. Paint tail skid orange.	
72	Approved unit insignia.	

Figure 9-23. Interior and Exterior Markings, OH-58 (Sheet 12 of 13)

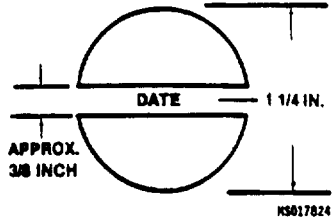


CODE NO.	DIRECTIONS	WORDING
73	Immediately above fuel filler cap. 1/2-in. air craft black letters.	AVOID CONTACT WITH INTERNAL FUEL LINES DURING SERVICING
74	Non-tactical aircraft only. Paint last 6 in. of antenna orange.	
75	OH-58C, center outboard of curved section fwd and aft of left and right antenna. 5/8-in. aircraft black letters.	NO PUSH
76	Aft of fuel shut off lever, 1/2-in. aircraft black letters on aircraft red background.	FUEL OFF
77	Fwd of fuel shut off lever, 1/2-in. aircraft black letters on aircraft red background	FUEL ON
78	Left side of aircraft, aft of passenger door, above Code 44, paint aircraft black. NOTE: Date shown on stencil is date aircraft painted with MIL-C-46168 paint.	 <p>The diagram shows a circular stencil marking. The word "DATE" is centered within the circle. To the left of the circle, a dimension line indicates a width of "APPROX. 3/8 INCH". To the right, a dimension line indicates a height of "1 1/4 IN.". Below the circle, the reference number "NS017824" is printed.</p>
79	Paint tail rotor gear box filler cap, orange-yellow.	

Figure 9-23. Interior and Exterior Markings, OH-58 (Sheet 13 of 13)

CAUTION  3/4 in.

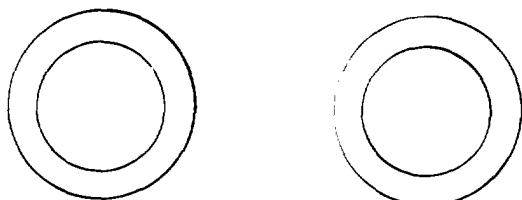
ENSURE SEAT  3/8 in.


**BELTS AND
CUSHIONS ARE
FASTENED AND
CLOSE DOORS
ON EXITING**

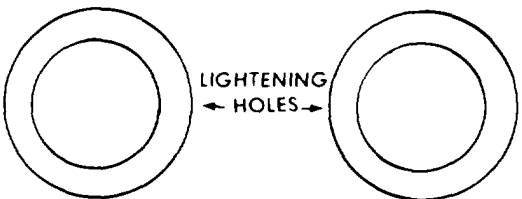
NOTE Use this caution when seat back armor is installed.
Paint MIL-C-46168, orange-yellow, No. 33538.

Figure 9-24. Interior Requirements to be Stenciled on the Back of Pilot's and Co-Pilot's Seat Backs, OH-58A/C (Sheet 1 of 2)

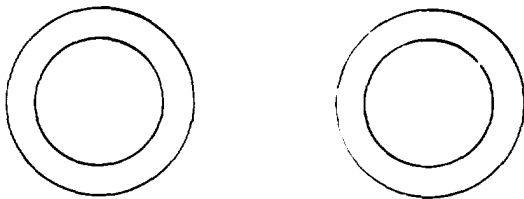
CAUTION  3/4 in.



ENSURE SEAT BELTS AND  3/8 in.



CUSHIONS ARE FASTENED AND



CLOSE DOORS ON EXITING

NOTE Use this caution when seat back armor is not installed.
Paint MIL-C-46168, orange-yellow, No. 33538.

Figure 9-24. Interior Requirements to be Stenciled on the Back of Pilot's and Co-Pilot's Seat Backs, OH-58A/C (Sheet 2 of 2)

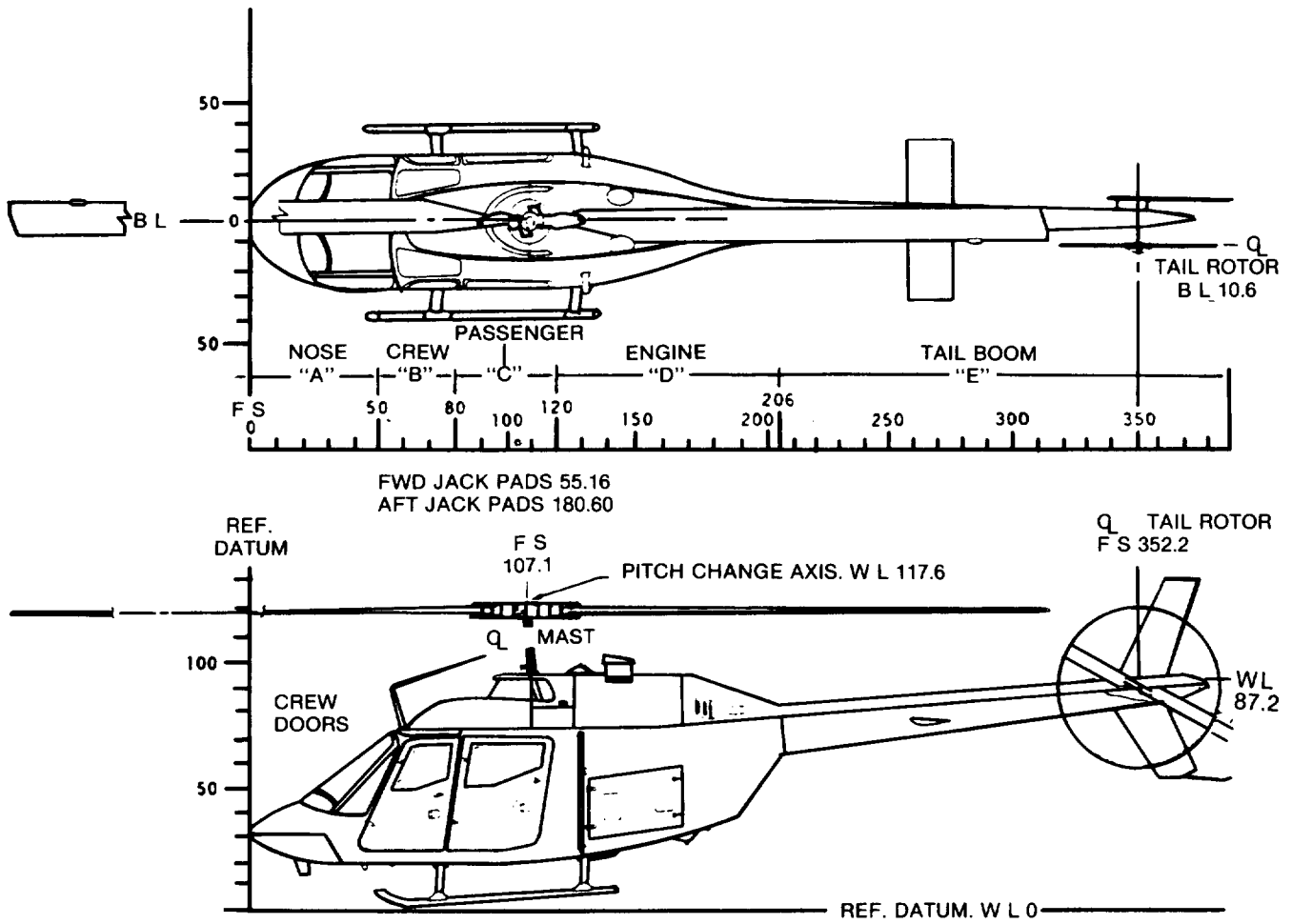


Figure 9-25. Station Diagram, OH-58

NOTE:

For high visibility paint scheme for main and tail rotor blades, see Chapter 6.

NOTE:

HIGH VISIBILITY PAINT WILL BE APPLIED TO SHADED AREAS.

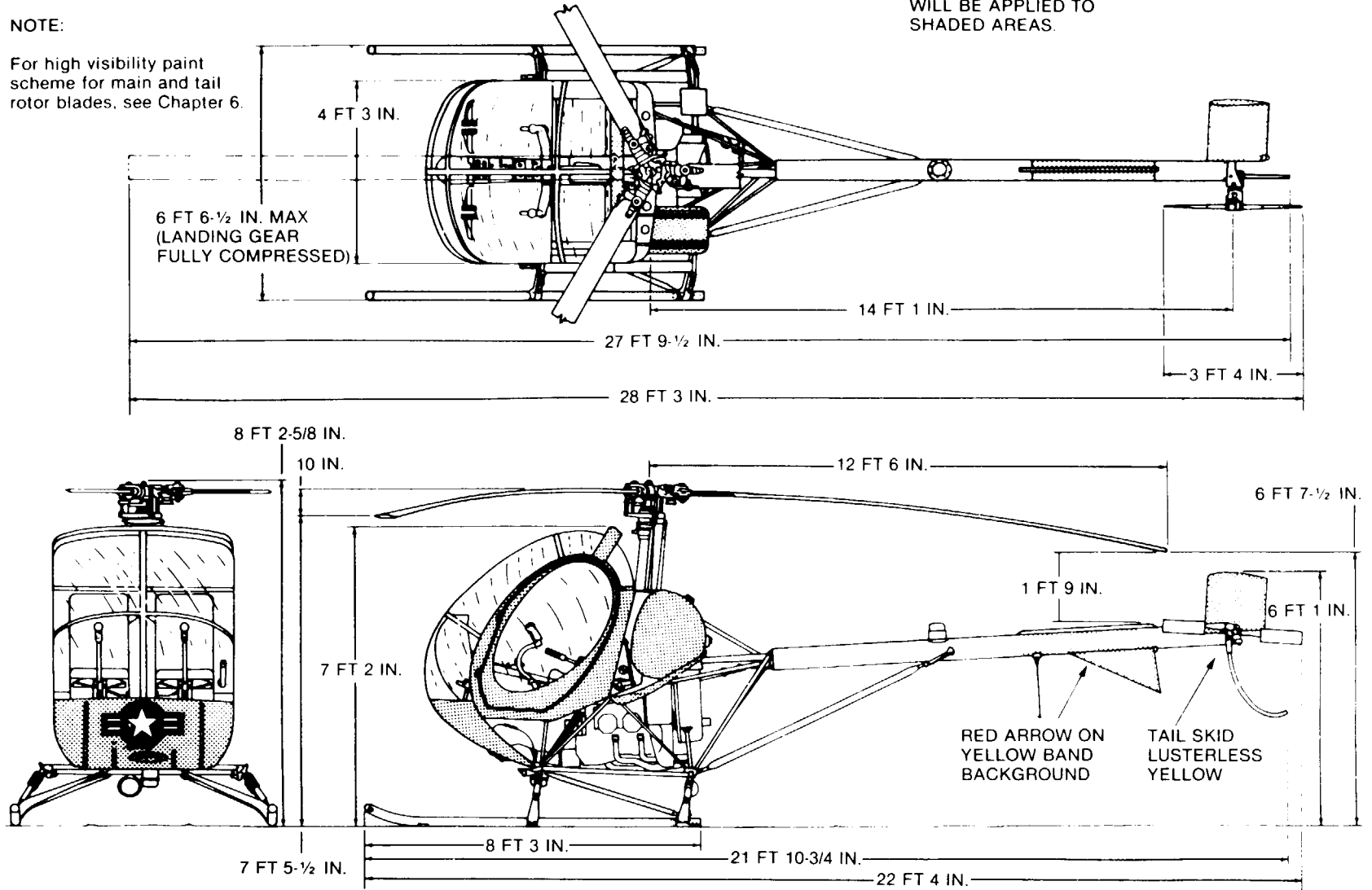
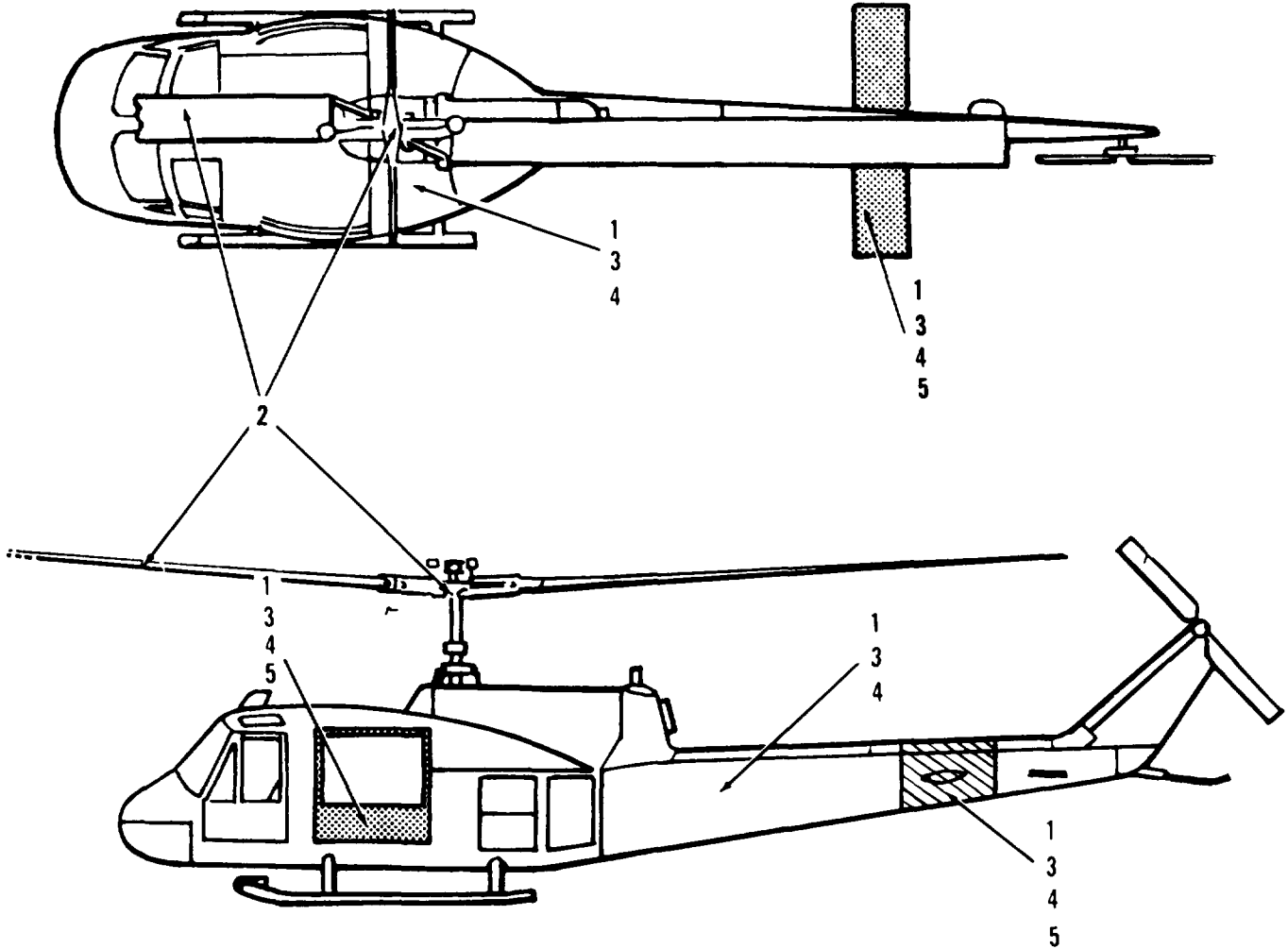


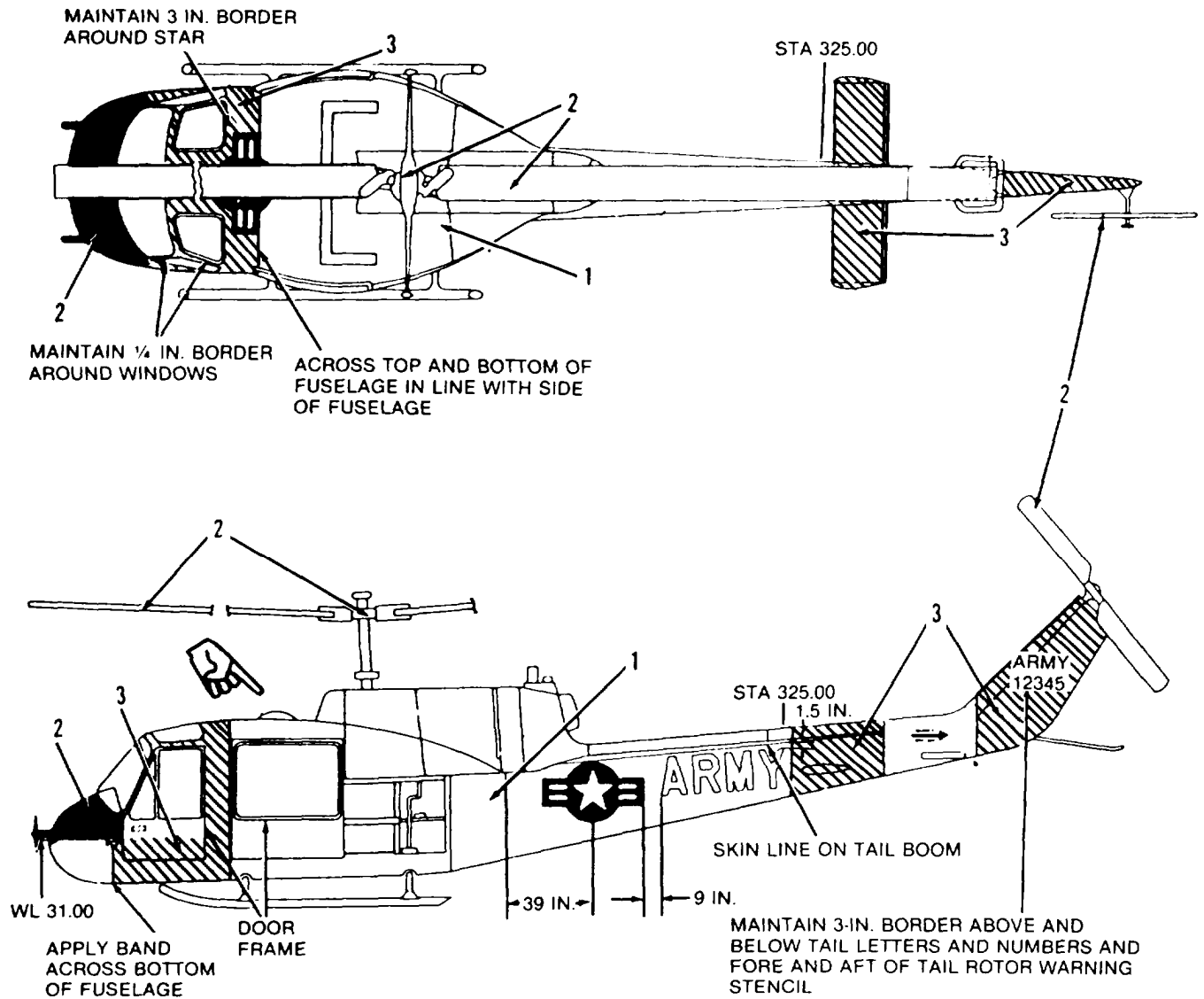
Figure 9-26. High Visibility Markings, TH-55

Section VIII. UH-1 ILLUSTRATIONS



1. MIL--C-46168, Aircraft Green (entire aircraft, except as noted).
2. MIL-C-46168, Aircraft Black.
3. MIL-C-46168, Dark Sand (entire aircraft or high conspicuous paint scheme when authorized, desert operations only). See Paragraph 5-11.
4. MIL-C-46168, Aircraft White (entire aircraft or high conspicuous paint scheme when authorized, arctic operations only). See Paragraph 5-11.
5. MIL-P-21600, Fluorescent Red-Orange. ANA #633 (training aircraft-high visibility, only where authorized).

Figure 9-27. Tactical Paint Scheme, UH-1C/M



1. MIL-C-46168, aircraft green (entire aircraft, except where noted).
2. MIL-C-46168, aircraft black.
3. MIL-P-21600, fluorescent red-orange, ANA #633 (shaded areas only).

Figure 9-28. Non-Tactical Arctic/Desert Paint Scheme, UH-1C/M

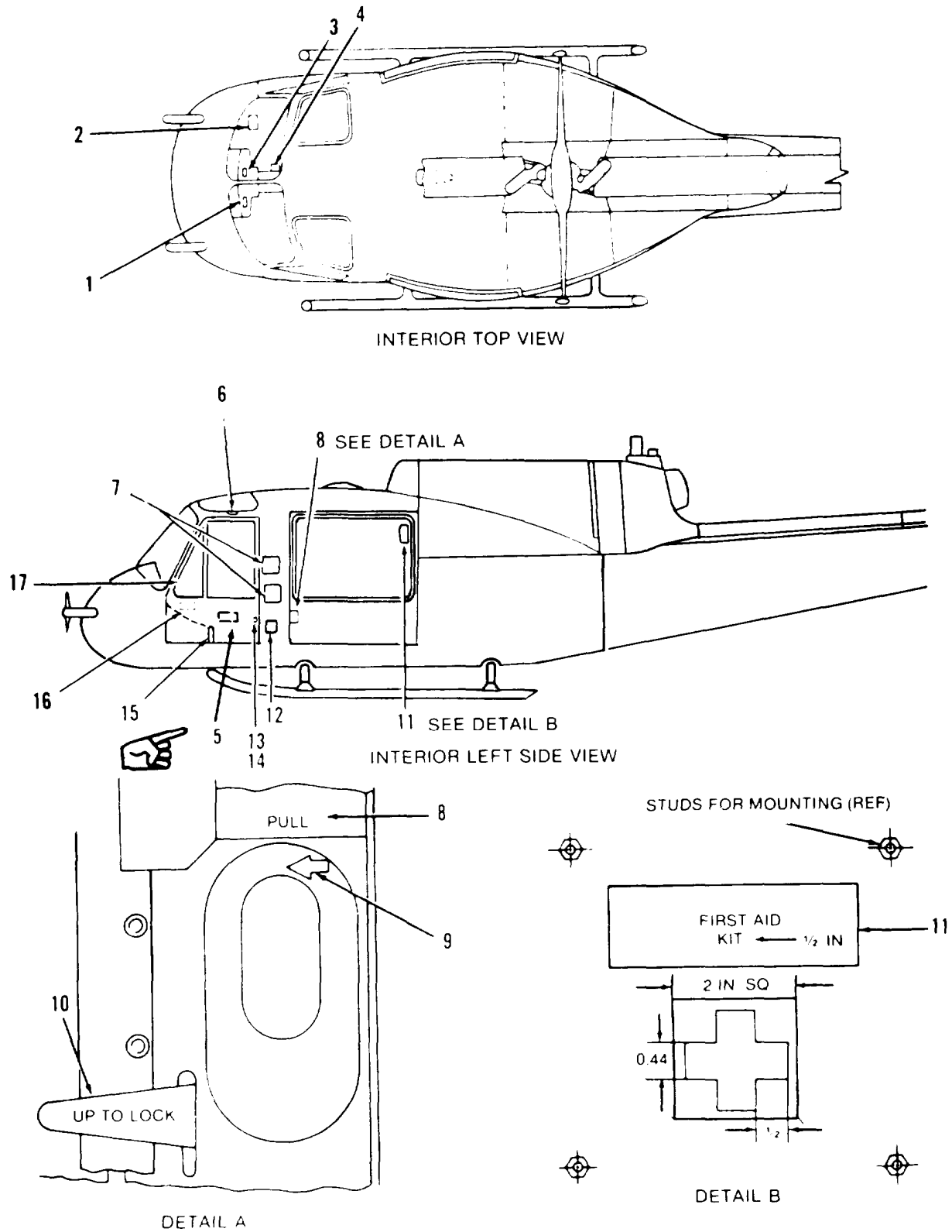


Figure 9-29 Interior Markings. UH-1C and UH-1M (Sheet 1 of 4)

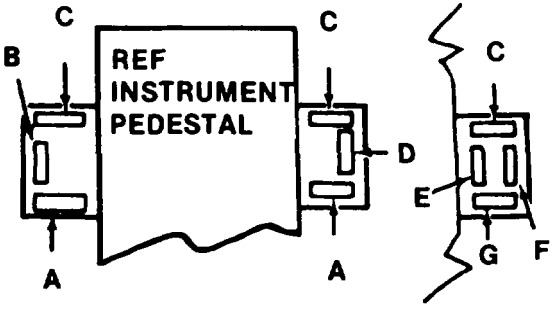
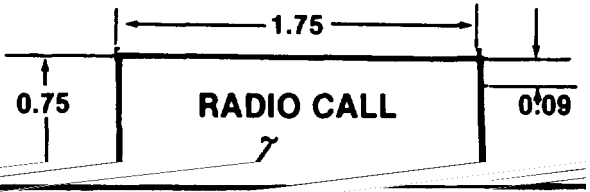
CODE NO.	DIRECTIONS	WORDING
1	Decals are located on heater and defroster controls in MIL-C-46168, aircraft white No. 37875 letters as shown. Note two different control markings for the right side.	 <p>A. CLOSED (3/16 IN.) B. CO-PILOT HEAT (1/8 IN.) C. OPEN (3/16 IN.) D. DEFROSTER LOWER (1/8 IN.) E. UPPER (1/8 IN.) F. LOWER (1/8 IN.) G. CLOSED DEFROST (3/16 IN.)</p>
2	Cargo release plate located on access panel AFT of cargo release pedal. Prime cargo release plate, one coat of MIL-P-23377, TY2, primer.	MANUAL CARGO RELEASE
3	Decal for radio call number is constructed of opaque dull black laminated plastic with white core, thickness 0.062. Lettering "RADIO CALL" to be engraved 0.12 in height. Radio call number to be engraved per MIL-M-18012. For field installation radio call number may be engraved or printed in white characters 0.188 to 0.375 high. Cement plate to upper left center of instrument panel with EC-847.	 <p>SPACE FOR INSERT RADIO CALL NUMBER</p>
4	Paint collective down lock handle aircraft white	
5	Paint broken band and EMERGENCY EXIT per. para 7-24.	EMERGENCY EXIT

Figure 9-29. Interior Markings, UH-1C and UH-1M (Sheet 2 of 4)



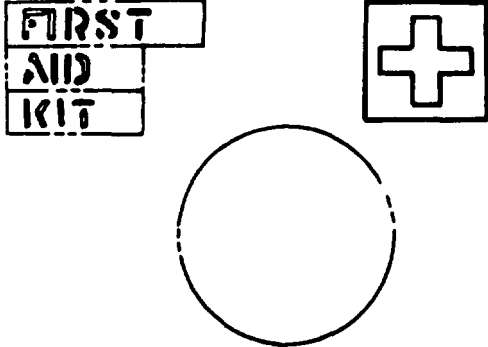

CODE NO.	DIRECTIONS	WORDING
6	Both sides of aircraft above side windows of crew doors and on cross-over bar in cabin roof recess, 1/2-in. aircraft white letters.	HAND HOLD
7	Stencil sound proofing blanket and door post, both sides of aircraft, 1/2-in. aircraft white letters.	STOWAGE
8	Above and to rear of door handles, 1/2-in. MIL-C-46168, aircraft black, No. 37038 letters.	PULL
9	Slightly below Code No. 8, arrow pointing aft, 1/2-in. aircraft black.	
10	On both cargo door handles, 1/2-in. aircraft black letters.	UP TO LOCK
11	Locate on structure and sound proofing 1/2-in. aircraft white letters, Stencil MIL-C-46168, aircraft red, No. 31136, cross on MIL-C-46168, aircraft white, No. 37875 background. Center between mounting studs on wall approximately 47.0 above top of floor, see Detail B.	<p style="text-align: center;">FIRST AID KIT</p>  <p style="text-align: center;">(STA 123.0)</p>
12	First Aid Kits mounted on door post will have letters and cross located outside of studs due to hole in structure. Stencil will be applied to sound proofing and structure approximate 4.0 or 17.0 in. above floor, see code no. 11 and detail B	 <p style="text-align: center;">(STA 68)</p>
13	Directly below door handles on both crew doors, 1-in. aircraft white letters.	TURN
14	Directly in front of turn sign, refer to Code No. 13, aircraft white arrow, 3/8-in. wide on transparent background, pointing in direction of rotation.	

Figure 9-29. Interior Markings, UH-1C and UH-1M (Sheet 3 of 4)


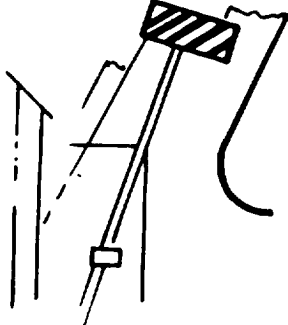
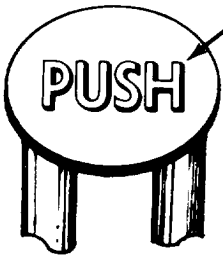
CODE NO.	DIRECTIONS	WORDING
15	Locate decal on end of instrument pedestal, 1/2-in. aircraft white letters.	HIGH VOLTAGE
16	Stencil both crew doors as shown, 1-in. aircraft white letters and arrow. Arrow points to Jettison handle only.	
17	Paint jettison handles alternate orange-yellow and black stripes, both sides refer to paragraph 7-24d.	
18	<p>NOTE: Seat must be in full down position to remove and install in Acft seat weight LBs pull handles to tilt seat back.</p>	<p>THE WORD NOTE WILL BE IN 1 INCH OLIVE DRAB, NO. 34087, LETTERS. ALL OTHER LETTERING WILL BE 1/2 INCH OLIVE DRAB, NO. 34087, LETTERS</p>
19	<p>Cargo Release Pedal, located between the pilot's anti-torque pedals.</p> <p>1. Paint cargo release pedal black, MIL-C-46168, TY2, No. 37038.</p> <p>2. Paint cargo release pedal raised letters "PUSH" White, MIL-C-46168, TY2, No. 37875.</p>	 <p>Raised letters</p>

Figure 9-29. Interior Markings, UH-1C and UH-1M (Sheet 4 of 4)

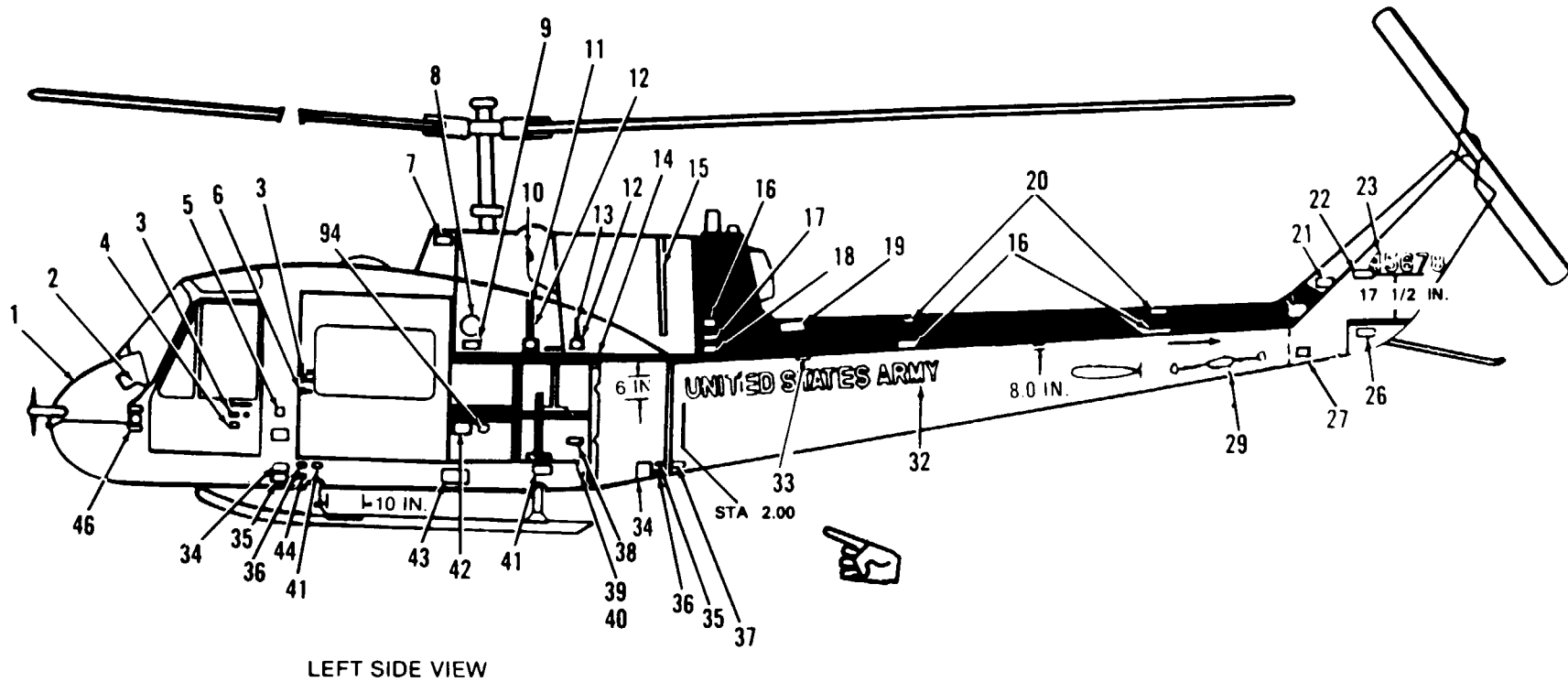


Figure 9-30. Exterior Markings, UH-1C and UH-1M (Sheet 1 of 17)

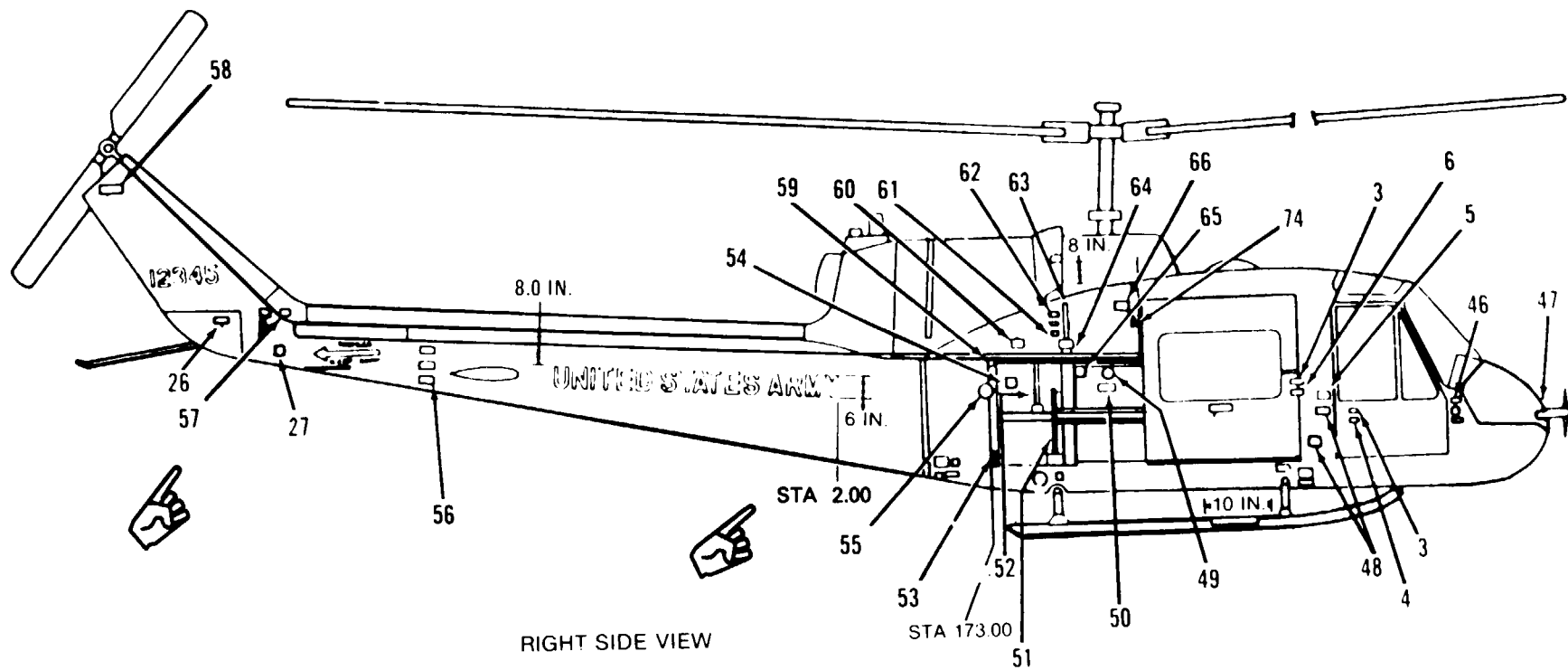


Figure 9-30. Exterior Markings, UH-1C and UH-1M (Sheet 2 of 17)

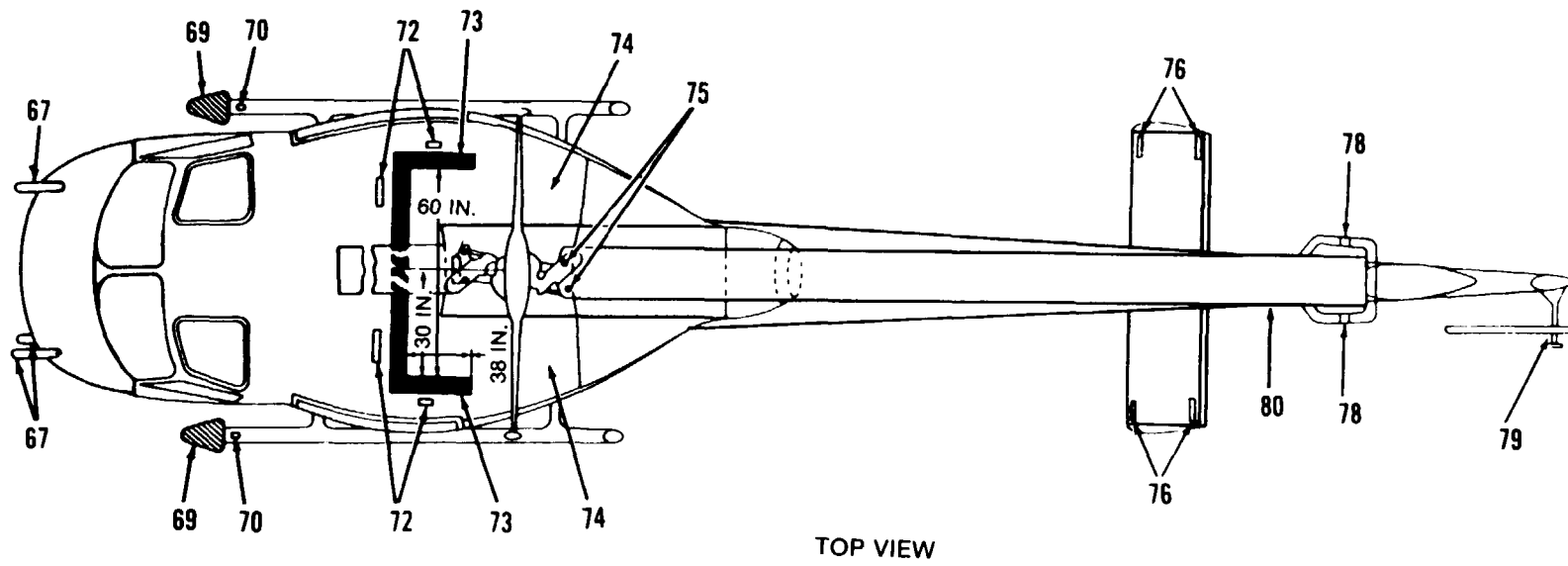


Figure 9-30. Exterior Markings, UH-1C and UH-1M (Sheet 3 of 17)

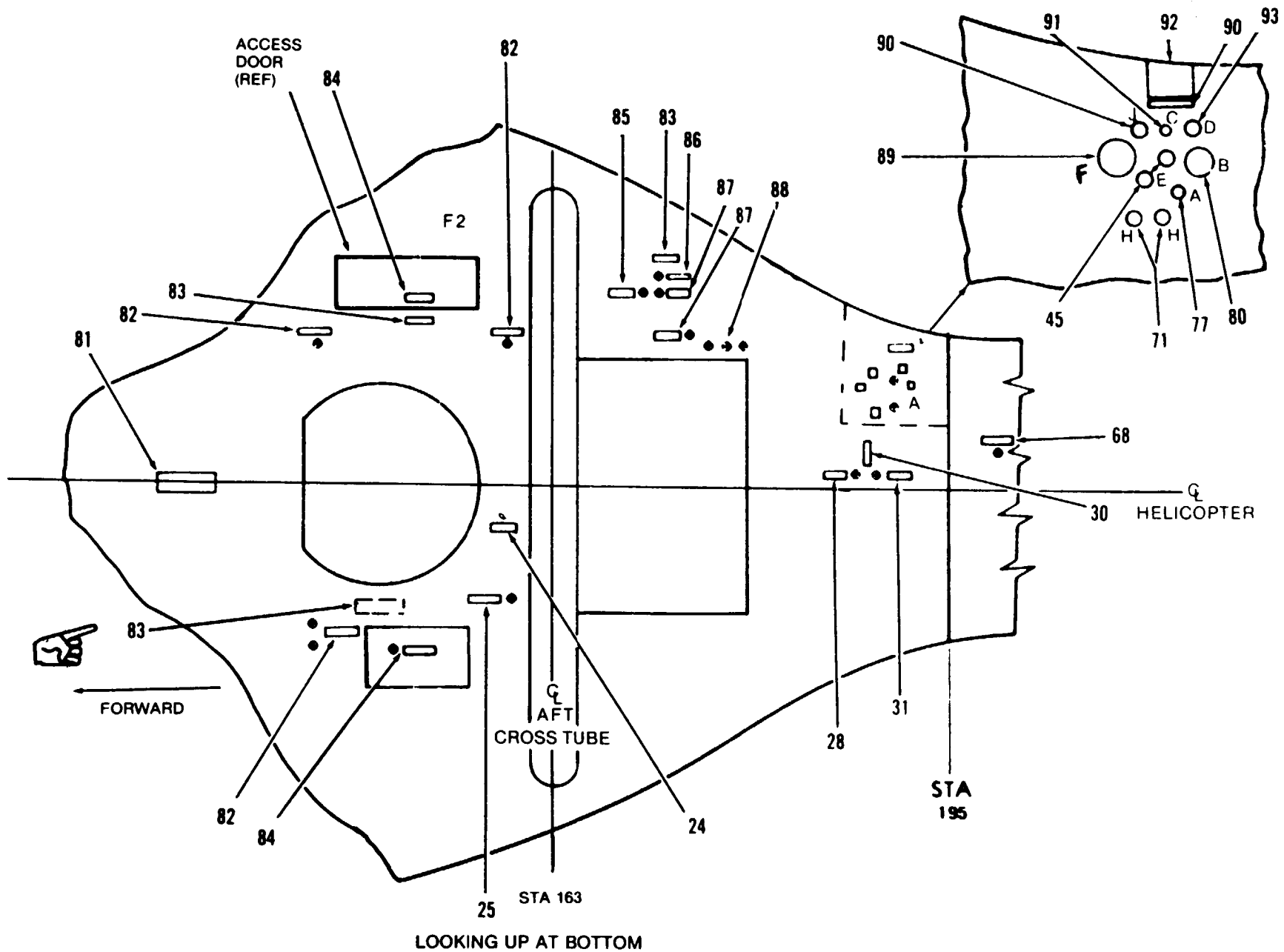
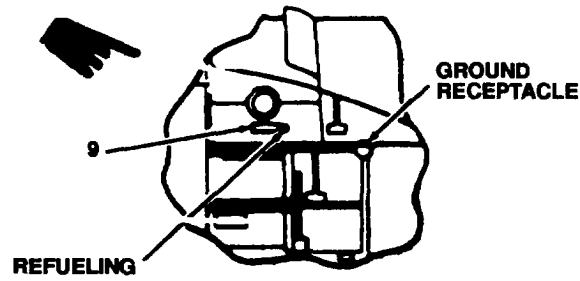


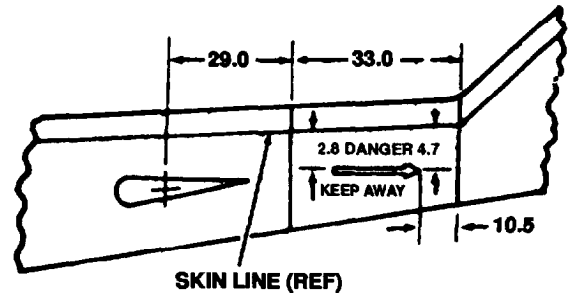
Figure 9-30. Exterior Markings, UH-1C and UH-1M (Sheet 4 of 17)

Change 1 9-137

TMS-1500-345-23



DETAIL A

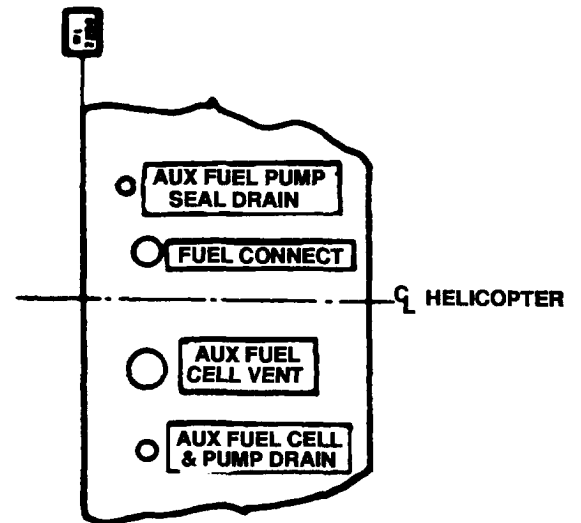


DETAIL B

- A STARTER GENERATOR OIL-DRAIN
- B OIL TANK VENT
- C FUEL FILTER DRAIN
- D ENGINE FUEL DRAIN
- E OIL TANK- TRAIN. OIL & FILTER SCUPPER DRAIN
- F FUEL CELL VENT
- G OIL COOLER DRAIN
- H ENG. FUEL DECK DRAIN
- J HEATER SUPPLY DRAIN

↑
 CHARACTERS TO BE 36 POINT
 TEMPO HEAVY CONDENSED
 LODLOW

DETAIL C



DETAIL D

Figure 9-30. Exterior Markings, UH-1C and UH-1M (SHEET 5 of 17).








CODE NO.	DIRECTIONS	WORDING
1	Authorized placement of unit insignia is on nose compartment access panel.	
2	Left side of helicopter with arrow pointing aft. Arrow should not extend beyond word "EXTINGUISHER." 1/2-in. MIL-C-46168 aircraft black No. 37038 letters and arrow. See code 48 for alternate location.	HAND FIRE EXTINGUISHER INSIDE 
3	Under cockpit and cabin door handles. Both sides of helicopter. Arrow is 1-1/2 in. Long with 1/2-in. shaft and 1/2-in. arrow head. Arrow should be on side of word to show travel of handle. 1/2-in. black letters.	 TURN 
4	Locate under word "TURN," below both crew door handles, 1-in. black letters. See code No, 3.	PULL
5	Both sides of cabin between doors. Midway between cockpit and cabin door handles. 1-1/2 in. arrow pointing toward handles, 1-in. black letters	 EXIT RELEASE TURN 
6	Locate below "TURN," 1-in. black letters, arrows same size as those for code No. 3.	 SLIDE 
7	On each side and top of fiberglass duct 1/2-in. black letters.	NO STEP
8	DELETE	
9	UH-1C and UH-1M. Locate below fuel filler cap, 1/2-in. black letters. See Detail A.	CAP.227.6 U.S. GALS USE JP-4 MIL-T-5624 IF NOT AVAILABLE REFER TO TB55-9150-200-24 FOR ALTERNATE FUEL
10	Right side engine air scoop, 1/2-in. black letters.	HAND HOLD

Figure 9-30. Exterior Markings, UH1C and UH-1M (Sheet 6 of 17)

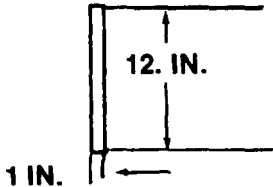
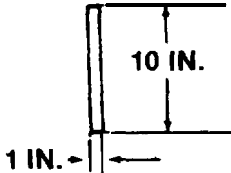
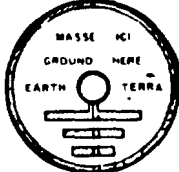
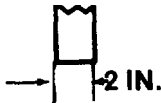
CODE NO.	DIRECTIONS	WORDING
11	Paint vertical black stripe above center of upper forward kick-in doors.	
12	Both sides of aircraft on upper kick-in doors, 3 places, 1/2-in. black letters.	ACCESS FOR FIRE EXTINGUISHER STEP
13	Paint a vertical black stripe above center of upper aft kick-in doors.	
14	UH-1M. Left side of fuselage 1/2 inch, Black letters (See MIL-C-83413/9-2 for dimensions).	
15	Paint a 2 in. wide black stripe over top of cowling to show turbine wheel location and stop the line at the bottom of the cowling. Location will be 10-1/2 inches forward from rear cowling.	
16	Locate on access door left side of exhaust fairing and drive shaft cover, 3 places. 1/2 inch black letters.	DRIVE SHAFT ACCESS
17	Locate below access door, code No. 16, 1/2-in. black letters.	ELECTRICAL DISCONNECT ACCESS
18	Locate below access door, and code Nos. 16 and 17, 1/2-in. black letters.	TAIL BOOM MOD PLATE INSIDE
19	Locate on access doors, both sides of aircraft, 1/4-in. black letters.	DIRECTION CONTROL PULLEY ACCESS
20	Locate inside of drive shaft covers above couplings. 1/2-in. black letters.	INSTALL SHAFT CLAMP INDEXED 90° TO EACH OTHER TORQUE TO 30-35 IN-LB

Figure 9-30. Exterior Markings, UH-1C and UH-1M (Sheet 7 of 17)

CODE NO	DIRECTIONS	WORDING
21	Left side of drive shaft cover. (Not applicable to IR aircraft.) 1/2-in. black letters.	DRIVE SHAFT ACCESS
22	Locate parallel to ground below tail rotor tie down loop. 1/2-in. black letters.	TAIL ROTOR TIE DOWN
23	Radio call numbers are 17-1/2 in. above tail skid fairing and parallel to the ground, 6 in. high, black numbers, both sides.	12345
24	Size 1 in. x 13 in. with 1/4-in. black letters. Locate outboard of drain, top of letters inboard.	FUEL CROSSOVER TRAP DRAIN
25	Size 1-7/8 in. x 10-7/8 in. with 1/2-in. black letters on RH side fwd of crossover tube. Top of letters inboard.	HYDRAULIC RESERVOIR SCRUPPER & PUMP CASE DRAIN
26	Both sides of tail boom fairing 1/2-in. black letters.	NO PUSH
27	Locate both sides of tail boom and as close to fitting as possible, 1/4-in. black letters.	FOR AIR TRANSPORT TIE DOWN ONLY
28	Size 1 in. x 4-5/8 in. with 1/2-in. black letters. Center of caption aft and against drains with top of letters inboard, (if applicable).	HEATER DRAIN
29	<p>TAIL ROTOR WARNING. Black arrow 3 in. wide, 21.75 in. long including 4 x 4-1/2 in. arrow head. Locate arrow 4 in. above parallel with centerline of antenna extending 8.5 in. past forward end of antenna mount. 1-3/4 black letters. See detail B.</p>	<p>The diagram shows a warning sign consisting of a black arrow pointing to the right. The arrow is 3 inches wide and 21.75 inches long, including a 4 x 4-1/2 inch arrowhead. The word "DANGER" is printed above the arrow, and "KEEP AWAY" is printed below it. A 4.5 inch tail extends to the right of the arrowhead. Below the sign is a detail of an antenna mount, showing a horizontal antenna with a dashed line indicating an 8.5 inch extension past the forward end of the antenna mount. The label "ANTENNA (REF)" is positioned to the left of the antenna detail.</p>
30	Size 2-3/8 x 7-5/8 in. transparent background with 1/2 in. black letters. Located outboard of drain with tops of letters facing fwd, (if applicable).	HEATER FUEL CONTROL BOX DRAIN
31	Size 1-7/8 x 4-1/2 in. transparent background with 1/2 in. black letters. Located aft of drain with tops of letters inboard, (if applicable).	HEATER FUEL PUMP DRAIN

Figure 9-30. Exterior Markings, UH-1C and UH-1M (Sheet 8 of 17)


CODE NO.	DIRECTIONS	WORDING
32	<p>FOR TACTICAL AIRCRAFT Both sides of aircraft. Most forward letter (U-left side, Y-right side) to start at tail boom station 2.0. Top of letters are 8 inches down from and parallel to top skin seam. Letters to be 6 inches high black. Additional dimensions and spacing in accordance with fig. 8-2.</p>	UNITED STATES ARMY
33	Left and right side of tail boom below latch point, 1/2-in. black letters.	COWLING LATCH
34	Locate on both sides of aircraft forward of mooring points, 4 required, 1/2-in. black letters.	<p>TIE DOWN RING MOORING LOAD ON RING NOT TO EXCEED 1000 LBS VERTICALLY 500 LBS LATERALLY 500 LBS FWD/AFT</p>
35	Left and right side of aircraft above mooring points and aft of code No. 34. 1/2-in. black letters.	MOOR
36	Left and right side of aircraft below "MOOR" code No. 35, 3 or 4 places, 1/2-in. black letters.	JACKING POINT
37	Locate on left and right bottom edge of tail boom with arrow pointing forward to jack point, 2 required, 1/2-in. black letters.	<p>JACK HERE </p>
38	Locate on access door, 3 in. from back of compartment and 6-1/2 in. from top of door, 1/2-in. black letters.	BATTERY ACCESS
39	Locate on external power receptacle door, 1/2-in. black letters.	28V D.C.
40	Locate adjacent to access door, code No. 39, 1/2-in. black letters.	EXTERNAL ELECTRICAL CONNECTION

Figure 9-30 Exterior Markings, UH-1C and UH-1M (Sheet 9 of 17)


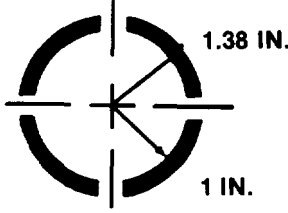
CODE NO.	DIRECTIONS	WORDING
41	Locate directly above front and rear cross tubes both sides of aircraft, 1/2-in. black letters.	<p>CROSS TUBE</p> <p>MOORING LOAD NOT TO EXCEED</p> <p>- F W D -</p> <p>2600 LBS VERT DN 5000 LBS FORE & AFT</p> <p>- A F T -</p> <p>3500 LBS VERT DN 5000LBS FORE & AFT</p>
42	Left side of aircraft, aft of cargo door, approximately 4 in. above floor line. First three lines 1-in. black letters and numerals, all others are 1/2 in.	<p>U.S. ARMY UH-1 U.S.A. SERIAL NO. (INSERT SERIAL NO.) SERVICE THIS HELICOPTER WITH MIL-T-5624 GRADE JP-4 AVIATION FUEL</p> <p>IF NOT AVAILABLE REFER TO TB 55-9150-200-24</p>
43	Left and right side of fuselage. Lower-panel at rear of cabin door opening. 1-in. black letters.	<p>CARGO HOOK MAX. LOAD 4000 lbs.</p>
44	Locate on both sides of aircraft above jack points, 2 required, 1/2-in. black letters.	<p>JACK HERE</p> 
45	Locate 1/2-in. black letter "E" for oil tank-trans oil & filter scupper drain, fwd of drains, top of letters facing inbd.	<p>E</p>
46	<p>UH-1M. Left and right hand side of aircraft, 1/4-in. black letters.</p> <p>NOTE Applicable only to aircraft equipped with nose mounted pitot tube.</p>	<p>STATIC PORT</p>  <p>DO NOT PLUG OR DEFORM HOLES</p>

Figure 9-30. Exterior Markings, UH-1C and UH-1M (Sheet 10 of 17)


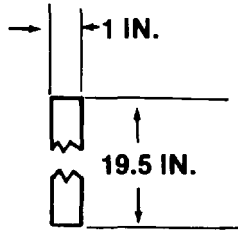
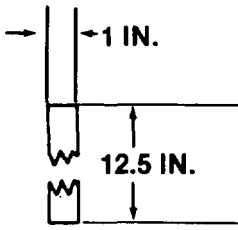
CODE NO.	DIRECTIONS	WORDING
47	Center of radio compartment door below antiglare paint, 1/2-in. black letters.	RADIO ACCESS
48	Letters are 1/2-in. black and arrow should not extend beyond word extinguisher.	HAND FIRE EXTINGUISHER INSIDE 
49	DELETE	DELETE
50	DELETE	DELETE
51	Paint 1 in. wide black stripe 19.5 in. long. Run stripe up to the cargo door track and center on the top of kick-in doors. Both sides of aircraft.	
52	Paint 1 in. wide black stripe 12.5 in. long. Run stripe up to the cargo door track and center on the top of kick-in doors. Both sides of aircraft.	
53	Locate engine oil cooler decal, part number 204-070-544-1,9 in. above baggage compartment floor on right side of bulkhead at station 173.0. Paint black.	
54	Locate on right rear access door aft of step stripe and centered on door, 1/2-in. black letters.	HEATER ACCESS

Figure 9-30. Exterior Markings, UH-1C and UH-1M (Sheet 11 of 16)






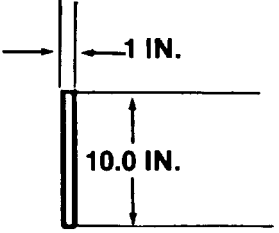
CODE NO.	DIRECTIONS	WORDING
55	Locate at station 173 an right side of helicopter which has had heater exhausts relocated to this position. Stencil the Words "DANGER EXHAUST" on the stiffner securing the wire cover. The wire cover and stiffner will be the some color as the adjacent surface. Use 1/4-in. black letters.	
56	<p>a. Right side of toil boom, AFT of elevator. 1/4 inch letters "Rivet P". Paint rivet head same color as adjacent surface. The arrow will point to the specific rivet for travel.</p> <p>b. Right side of tail boom, AFT of elevator. 1/4 inch letters "Rivet S". Arrow 1/2 inch long, 1/8 inch shaft, pointing down. Paint rivet head same color as adjacent surface. The arrow will point to the specific rivet for travel.</p> <p>c. Right side of tail boom, AFT of elevator. 1/4 inch letters "Rivet R". Paint rivet head same color as adjacent surface. The arrow will point to the specific rivet for travel.</p>	<p>MAX. ELEV. NOSE DOWN RIVET P </p> <p>FULL AFT CYCLIC STICK RIVET S </p> <p>FULL FWD CYCLIC STICK RIVET R </p>
57	Right side of tail boom aft of 42° gear box cover 1/2-in. black letters.	<p>REMOVE TO SERVICE WITH MIL-L-23699 OIL ABOVE -25° F  MIL-L-7808 OIL BELOW -25° F</p>
58	Right side of aircraft directly below 90° gear box and 4 in. above ARMY, 1/2-in. black letters.	<p>SERVICE GEAR BOX MIL-L-23699 ABOVE -25° F MIL-L-7808 BELOW - 25° F</p>
59	Right side of fuselage, 1/4-in. black letters, above switch.	<p>TRANS OIL LIGHT SWITCH</p>
60	Paint 1 in. wide black stripe 10 in. long above center of kick-in doors. Both sides of aircraft.	
61	Locate right aft lower corner of cowl door, 1/2-in. black letters.	<p>ENGINE OIL TANK INSIDE MIL-L-23699 ABOVE -25° F MIL-L-7808 BELOW - 25° F</p>

Figure 9-30. Exterior Markings, UH-1C and UH-1M (Sheet 12 of 17)

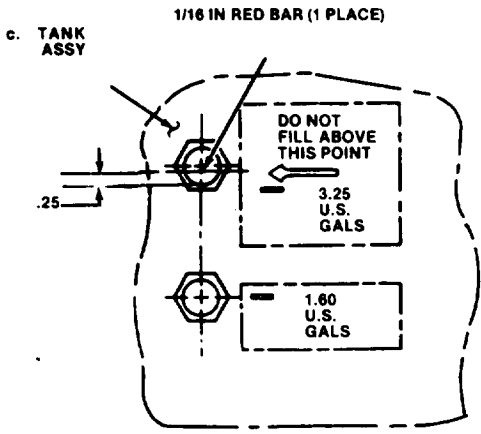
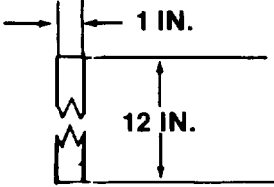
CODE NO.	DIRECTIONS	WORDING
62	<p>a. Locate inside right transmission cowl on oil tank. Stencil NO STEP on top of reservoir, 1/2-in. black letters.</p> <p>b. On side of tank adjacent to filler cap stencil service instructions 1/4-in. black letters.</p> <p>c. Replace decal on engine oil reservoir when marred and unreadable. Paint 1/16 in. MIL-C-46168, aircraft red, No. 31136, bar on sight glass to indicate full mark.</p>	<p>a. NO STEP</p> <p>b. OIL RESERVOIR MIL-L-23699 ABOVE -25°F MIL-L-7808 BELOW -25°F</p> <p>c. TANK ASSY</p> 
63	<p>Paint 1 in. wide black stripe 12 in. long above center of kick-in doors. Both sides of aircraft.</p>	
64	<p>Locate below right top forward kick-in door and edge of cowl, 1/2-in. black letters.</p>	<p>OIL LEVEL ACCESS</p>
65	<p>UH-1C. Locate on top aft edge of access door. 1 in. edge distance 1/2-in. black letters</p>	<p>HYDRAULIC ACCUMULATOR</p>
66	<p>Locate inside cowl on reservoir 1/2-in. black letters.</p>	<p>HYDRAULIC RESERVOIR</p>
67	<p>On top of each homing antenna housing and pitot tube at nose of aircraft. Top of letters facing inboard. 1/2-in. black letters.</p>	<p>NO PUSH</p>
68	<p>Size 1 in. x 5 in. with 1/2-in. black letters. Located outboard of drain with tops of letters facing inboard.</p>	<p>TAIL PIPE DRAIN</p>
69	<p>Paint steps of forward end of skid tubes with walkway coating. Both sides. Topcoat to match existing paint scheme.</p>	

Figure 9-30. Exterior Markings, UH-1C and UH-1SM (Sheet 13 of 17)

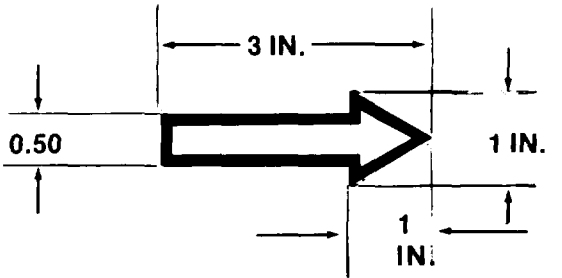
CODE NO.	DIRECTIONS	WORDING
70	Stencil top center of both skid tubes, top of letters facing inboard, 3 in. aft of step by towing eyebolt, 1/2-in. black letters.	TOW
71	Locate 1/2-in. black letter "H" for engine fuel deck drain. inbd of drains, top of letter facing outbd. Two required.	H
72	Four places on top of cabin. Top of letters facing away from walkway area, outbd and fwd, 1/2 inch black letters.	NO STEP
73	<p>Walkway area on top of fuselage. 2 in. black border. Fwd crossline is 1/4 in. aft of antenna housing.</p> <p style="text-align: center;">NOTE</p> <p>Walkway area on top of fuselage, will be painted with non-slip material MIL-W-5044, Type II. If necessary paint to match existing color scheme.</p>	
74	On left and right side of work deck to show location of steps while standing on work deck, arrow is painted black.	 <p>The diagram shows a black arrow pointing to the right. The total length of the arrow is 3 IN. The height of the arrow is 0.50 inches. The width of the tail of the arrow is 1 IN., and the width of the tip is also 1 IN. The arrow is centered vertically within a 1 IN. wide tail section.</p>
75	Paint 1/2 in. dot on upper and lower surface of blade, blade grip and rotating linkage. Color MIL-C-46168, aircraft white, No.37875. Paint dots on opposite blade, grip, and rotating linkage red. Check existing color code before painting	
76	Stencil top outboard edges of synchronized elevator, 4 places, 1/2 in black letters.	NO PUSH
77	Locate 1/2-in. black letter "A" for starter generator oil-drain, aft of drain, top of letter facing outbd.	A

Figure 9-30. Exterior Markings, UH-1C and UH-1M (Sheet 14 of 17)

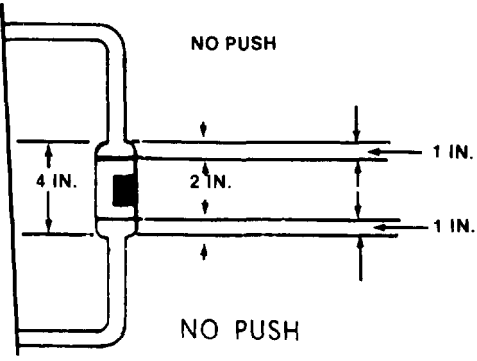
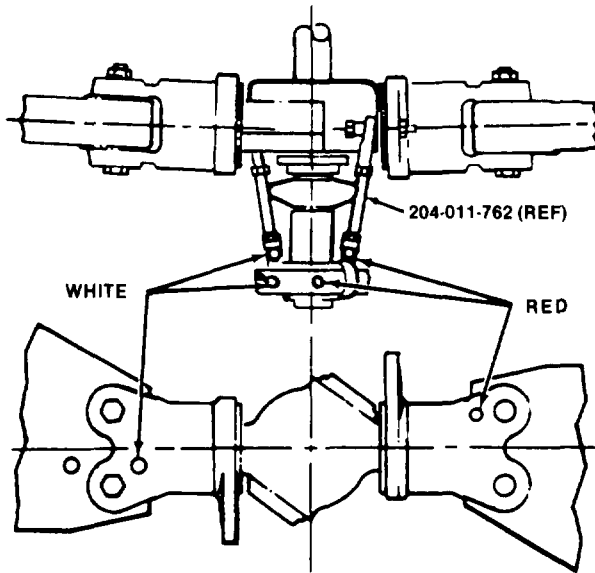
CODE NO.	DIRECTIONS	WORDING
78	Do not paint element centered on mounting horn located on each side of boom, stencil NO PUSH, 1/2 in. black letters on bend of antenna tubing, 4 required.	
79	Paint 1/2 in. white dots on tail rotor blade grip, pitch link and cross head. Paint red dots on opposite grip, link and cross head. Check existing color code before painting.	
80	Locate 1/2-in. black letter "B" for oil tank vent, aft of vent, top of letter facing outbd.	B
81	Locate on access door, see detail D for data for drains and vent. 1/2-in. black letters.	PROVISIONS FOR AUX FUEL DISCONNECTS
82	Size 1-7/8 in. x 6 in. with 1/2 in. black letters. One located on right side aft of drain and two on left side outboard of drain. Top of letters are inboard.	FUEL CELL CAVITY DRAIN and VENT

Figure 9-30. Exterior Markings, UH-1C and UH-1M (Sheet 15 of 17)

CODE NO.	DIRECTIONS	WORDING
83	Size 1-7/8 in. x 3-7/8 in. with 1/2-in. black letters centered 1-1/2 in. outboard of fuel cell drain with top of letters inboard 0.38 in. spacing between lines.	FUEL CELL DRAIN
84	Bottom fuselage on fuel pump access panels, both sides, 1/2-in. black letters.	FUEL PUMP ACCESS AND SUMP DRAIN
85	Top of letters facing inboard. Located forward of vent, 0.38 in. spacing between lines. 1/2-in. black letters.	AUX FUEL CELL VENT
86	Size 1 x 5 in. with 1/2-in. black letters. One located at station 170, BL 30, left; and one at station 158, BL17, left. Top of letters inboard and centered 3 in. forward of bottom vent.	BATTERY VENT
87	Size 2 x 5-3/8 in. with 1/2-in. black letters centered 3 in. below drain, 0.38 in. spacing between lines.	AUX FUEL PUMP SEAL DRAIN
88	Locate 1/2-in. black letter "G" for oil cooler drain, outbd of drains, top of letter facing outbd. Three required.	G
89	Locate 1/2-in. black letter "F" for fuel cell vent, fwd of vent and alined, top of letter facing outbd.	F
90	Locate 1/2-in. black letter "J" for heater supply drain, outbd of drain and centered, top of letter facing outbd.	J
91	Locate 1/2-in. black letter "C" for fuel filter drain, outbd of drain and centered, top of letter facing outbd.	C
92	Locate 1/4-in. black drain index letters "A" thru "H" beside drains at bottom of fuselage. See detail C.	
93	Locate 1/2-in. black letter "D" for engine fuel drain, aft of drain, top of letter facing outbd.	D

Figure 9-30. Exterior Markings, UH-1C and UH-1M (Sheet 16 of 17)

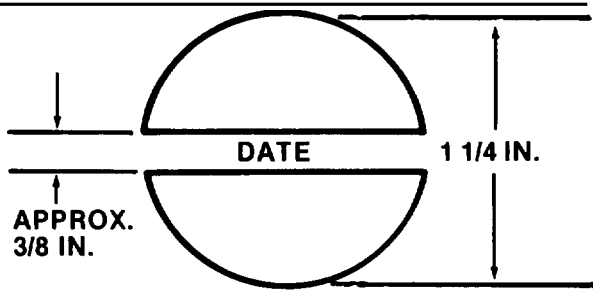
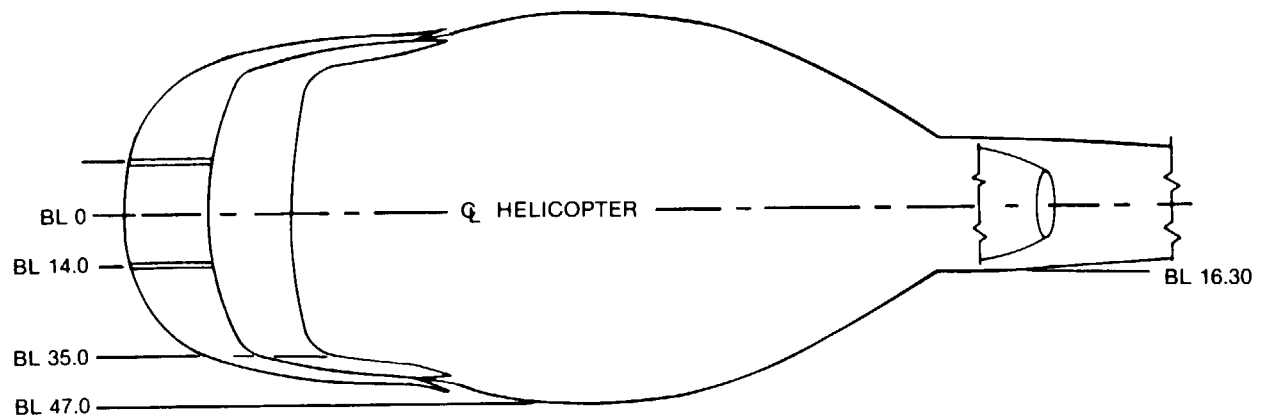
CODE NO.	DIRECTIONS	WORDING
94	LH side of aircraft aft of code 42. Aircraft black. Note: Date shown is date aircraft painted with MIL-C-46168 paint	 <p>The diagram shows a circle divided horizontally. The word "DATE" is centered between the two halves. A vertical double-headed arrow on the right indicates the diameter is 1 1/4 IN. A vertical arrow on the left points from the top edge of the circle to the center line, labeled "APPROX. 3/8 IN.".</p>

Figure 9-30. Exterior Markings, UH-1C and UH-1M (Sheet 17 of 17)



FS - FUSELAGE STATIONS
 BS - BODY STATION
 WL - WATER LINE
 BL - BUTTOCK LINE

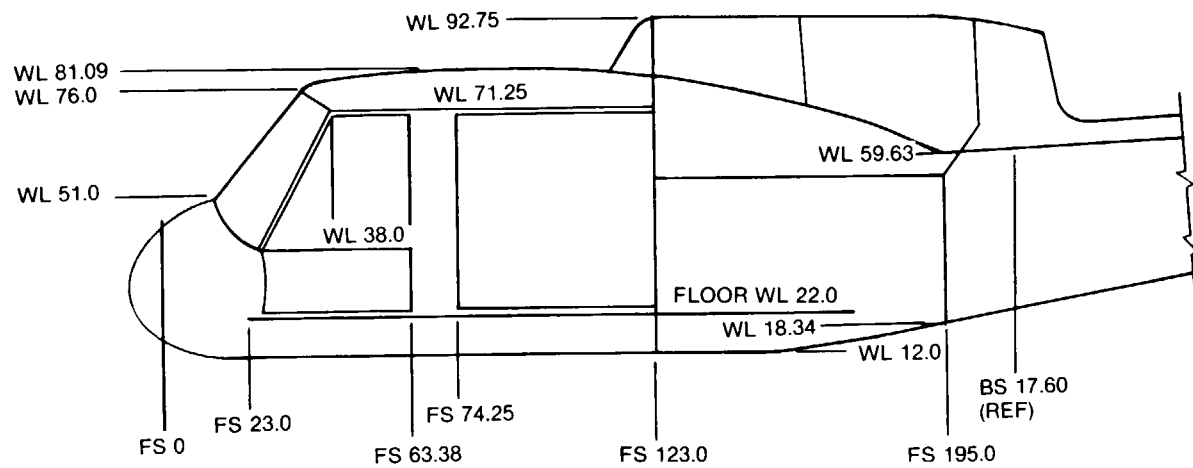


Figure 9-31. Station Diagram, UH-1C and UH-1M (Sheet 1 of 2)

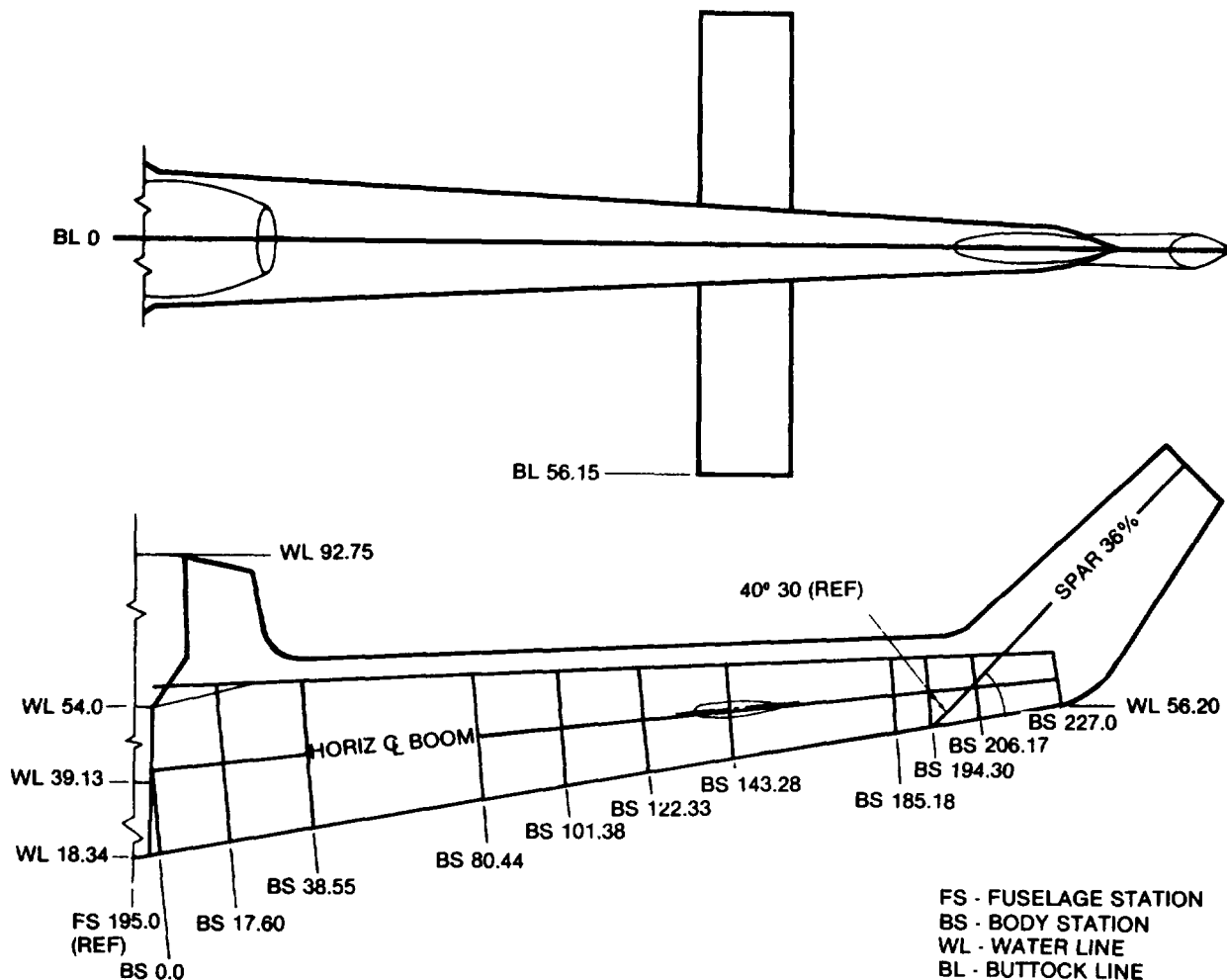
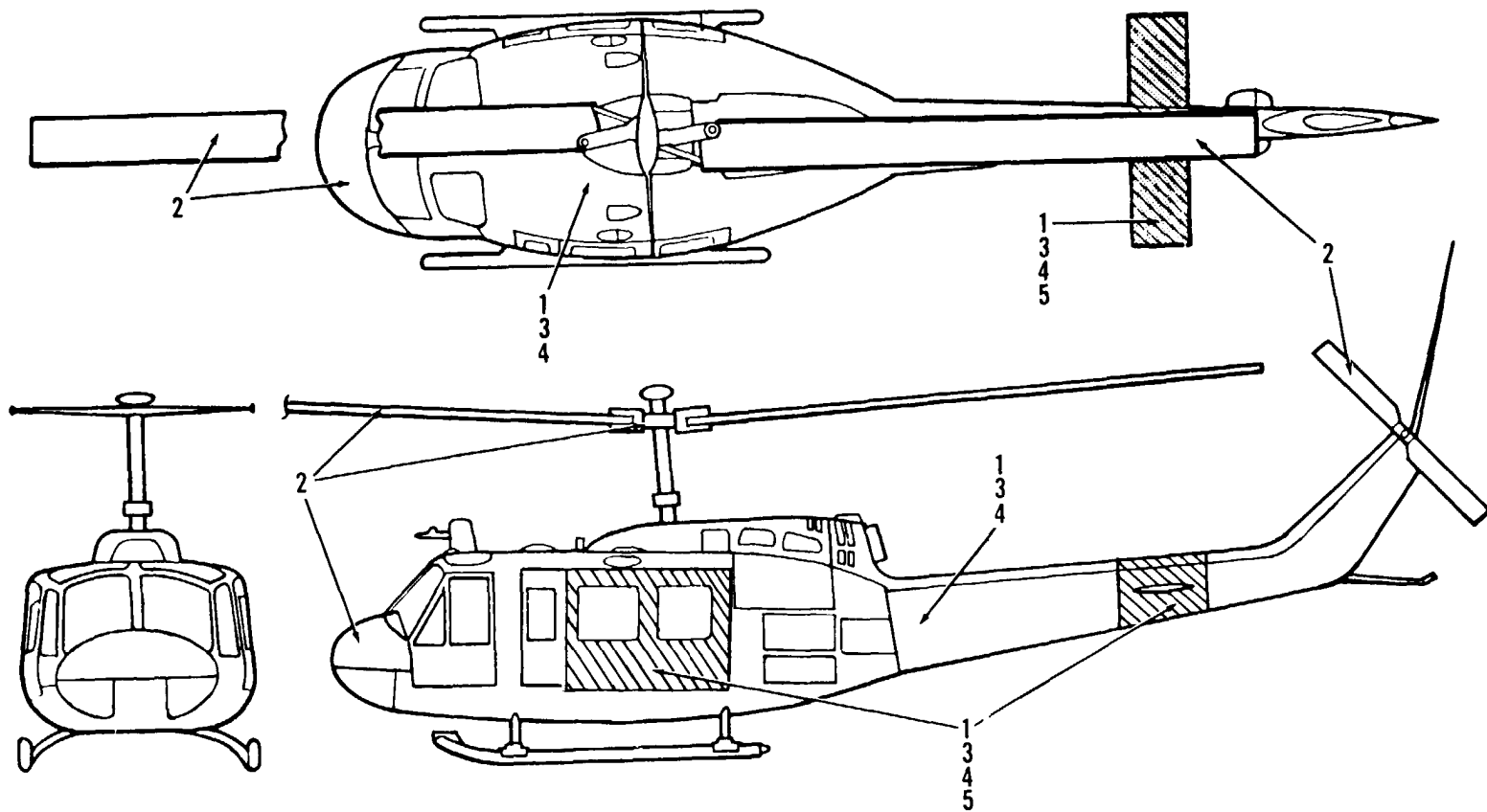
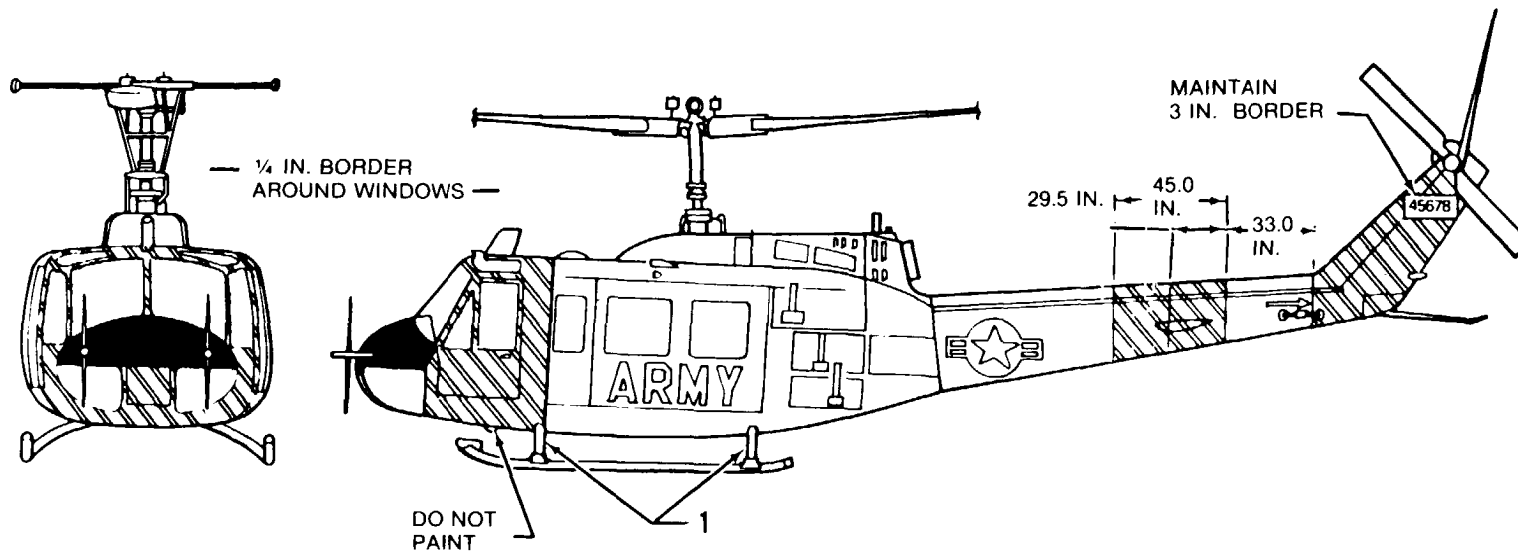
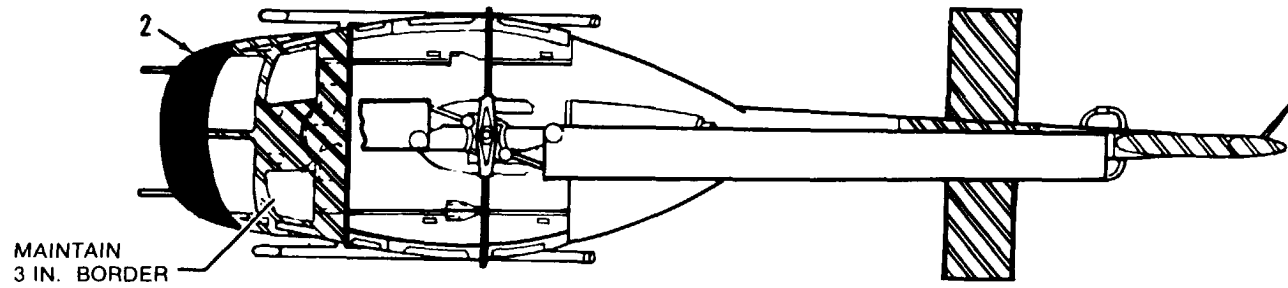


Figure 9-31. Station Diagram, UH-1C and UH-1M (Sheet 2 of 2)



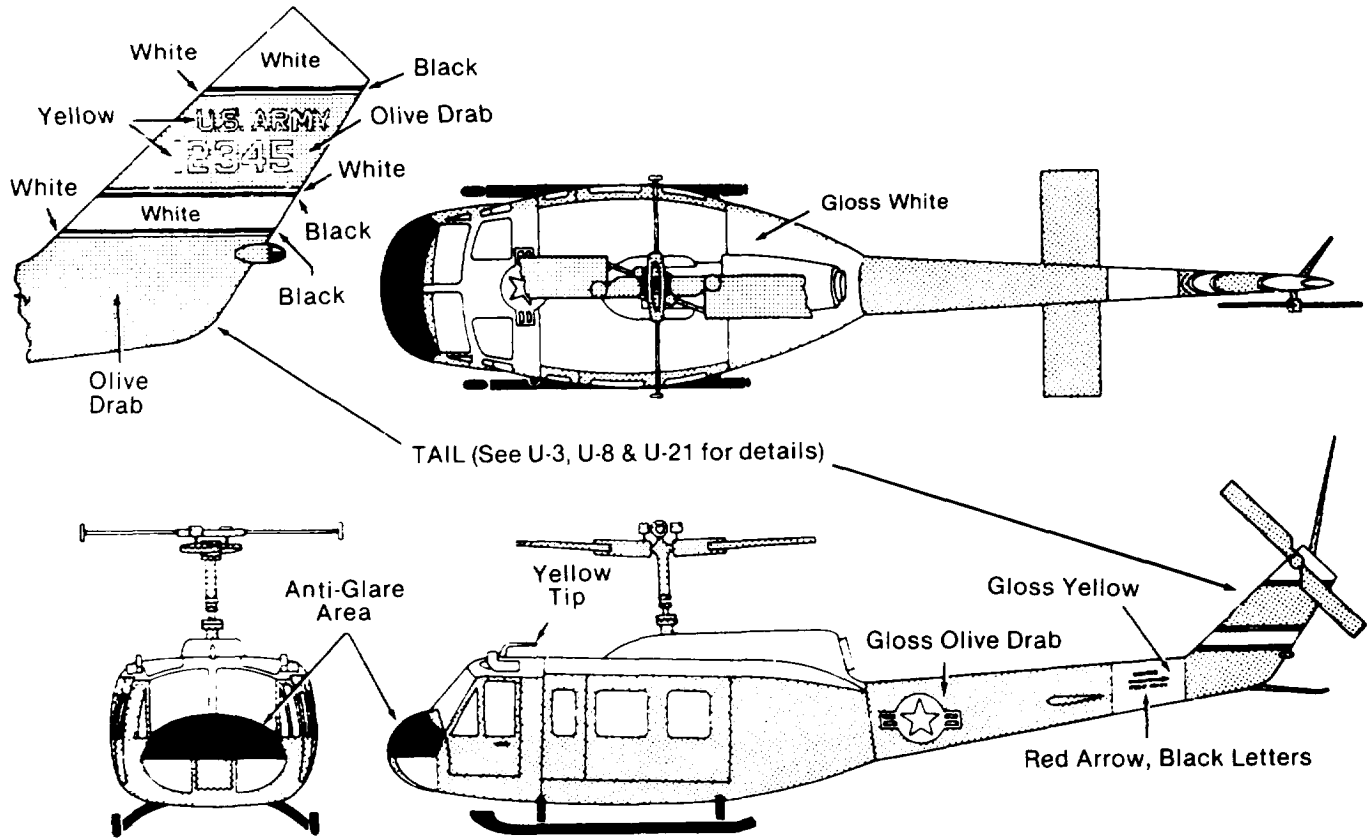
1. MIL-C-46168, Aircraft Green (entire aircraft, except as noted).
2. MIL-C-46168, Aircraft Black.
3. MIL-C-46168, Dark Sand (entire aircraft or high conspicuous paint scheme when authorized, desert operations only). See Paragraph 5-11.
4. MIL-C-46168, Aircraft White (entire aircraft or high conspicuous paint scheme when authorized, arctic operations only). See Paragraph 5-11.
5. MIL-P-21600, Fluorescent Red-Orange. ANA #633 (training aircraft-high visibility, only where authorized).

Figure 9-32. Tactical Paint Scheme, UH-1H/V



1. MIL-C-46168, aircraft green (entire aircraft, except where noted).
2. MIL-C-46168, aircraft black.
3. MIL-P-21600, fluorescent red-orange, ANA #633 (shaded areas only).

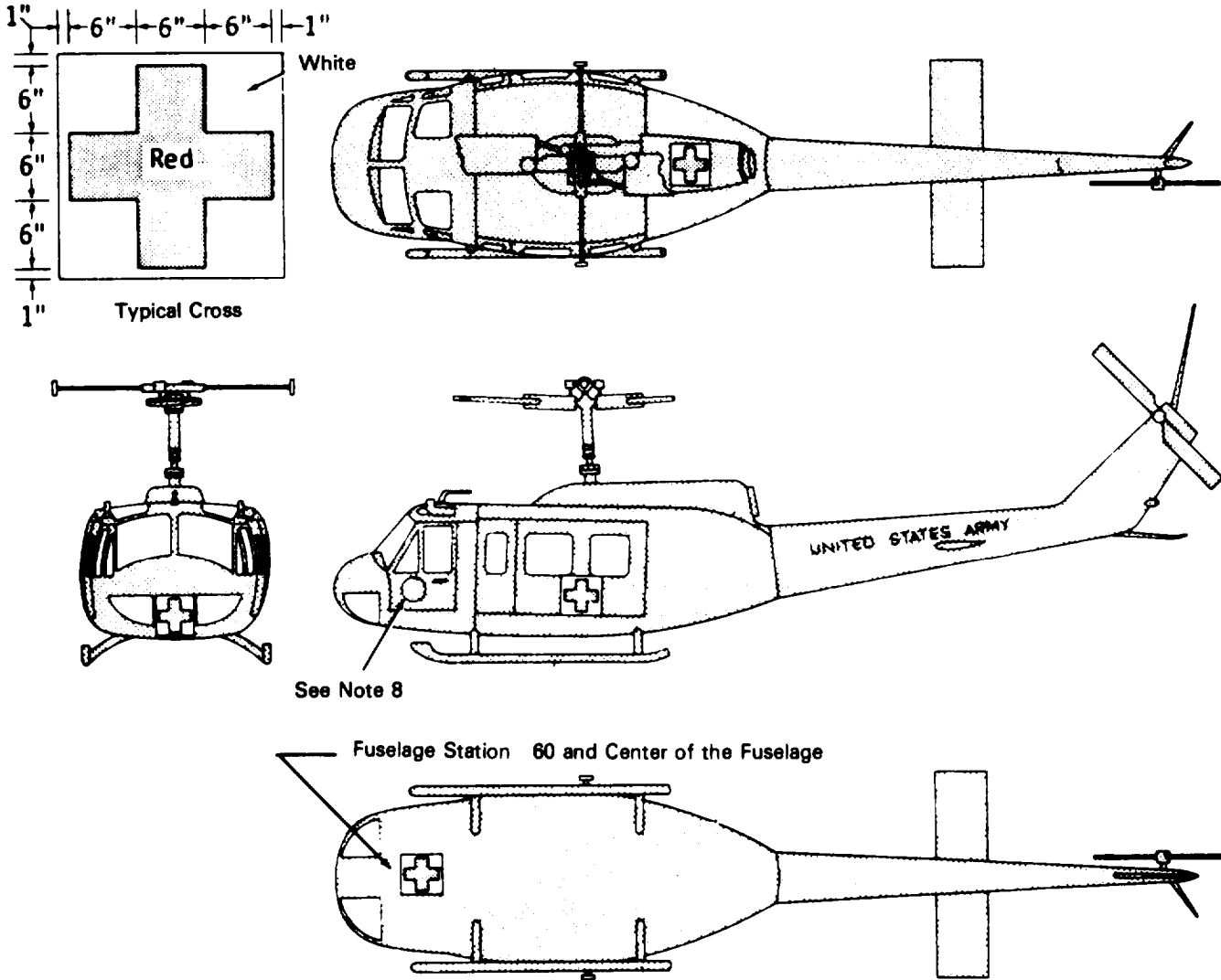
Figure 9-33. Non-Tactical Arctic/Desert Paint Scheme, UH-1H/V



NOTES:

1. Fuselage: Gloss Olive Drab
2. Roof, Including Engine Cowling: Gloss White
3. Blades: See Chapter 6.
4. Synchronized Elevator: International Orange
5. Anti-Glare Area: Lusterless Black.
6. National Star Insignia: Top, Bottom and Sides.
7. Skids and Cross Bars: Gloss Black up to Fuselage.
8. Information Wording: Gloss Yellow instead of Black.
9. Walkway: White.

Figure 9-34. Staff Transport UH-1D/H



See Note 8

NOTES:

1. Fuselage: Same as Tactical Paint Scheme.
2. Skids and Cross Bars: Same as Tactical Paint Scheme.
3. Informational Wording: Same as Tactical Paint Scheme.
4. Synchronized Elevator: Same as Tactical Paint Scheme.
5. Blades: See Chapter 6.
6. National Insignia: None.
7. Red Crosses: Size and Location Approximately as Shown.
8. Command and Organizational Insignia: Optional Position for Air Ambulance only.

Figure 9-35. Army Medical Service (Ambulance) UH-1D/H

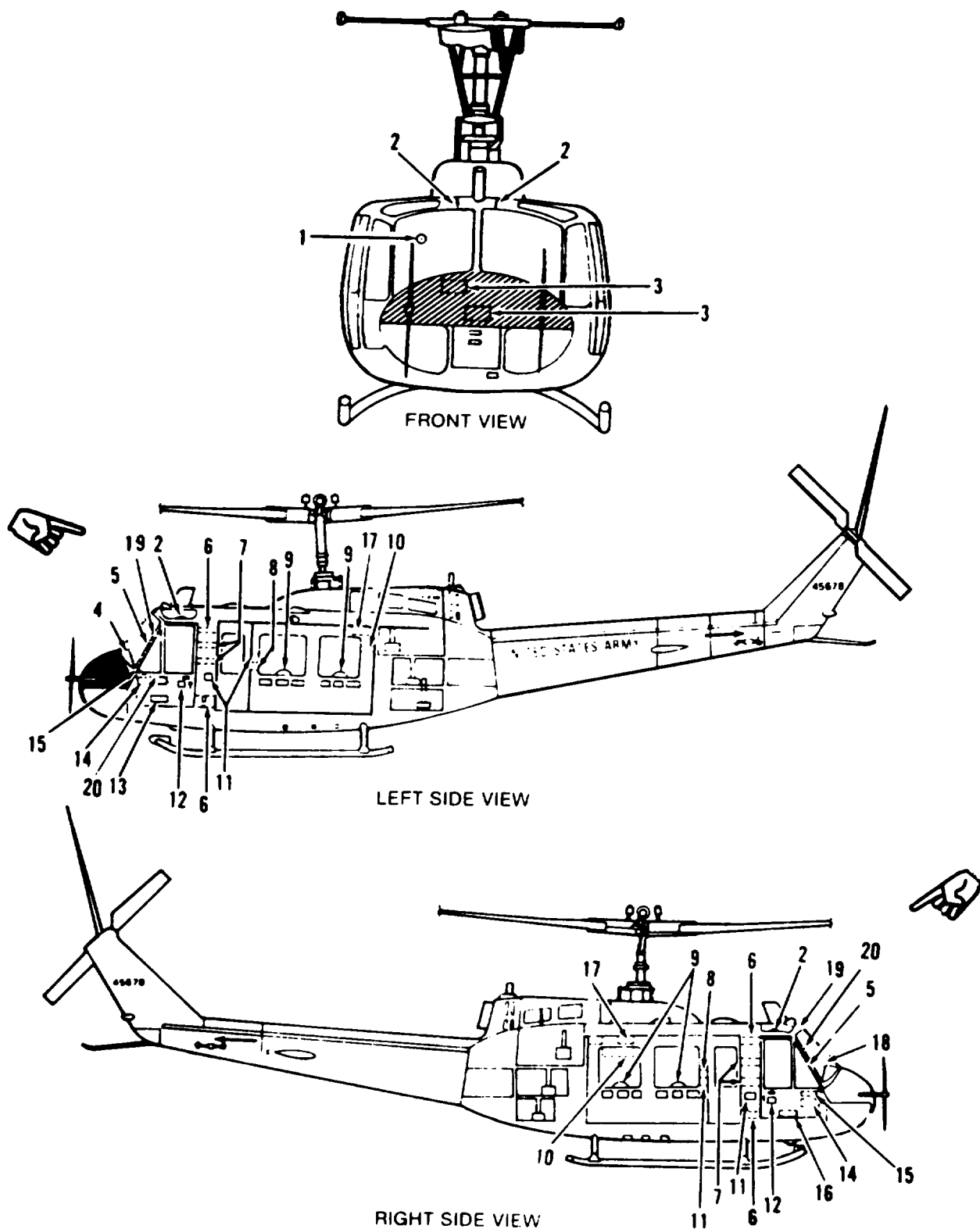


Figure 9-36. Interior Markings. UH-1D and UH 1H (Sheet 1 of 4)

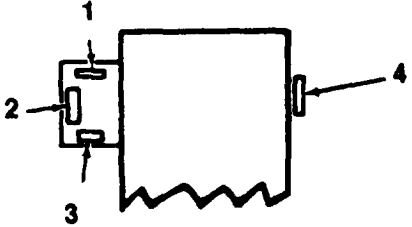
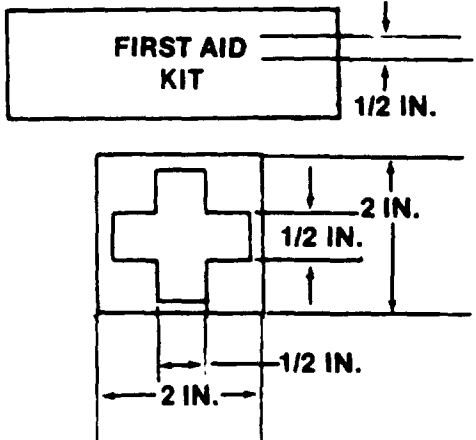
CODE NO.	Directions	WORDING
	Locate on sound proofing and on panel under sound proofing, 1/2-in, MIL-C-46168, aircraft white No. 37875 letters.	<p>XMSN OIL</p> <p>(Switch)</p> <p>LEVEL LIGHT</p>
2	Locate on cross bar in cabin roof and over both doors, 1/2-in. aircraft white letters. 4 required.	HAND HOLD
3	Locate on both sides of structural panels on foward side of pylon, station 129, 1/4 in. MIL C 46168, aircraft white, No. 37875 letters, 2 required.	STRUCTURAL PANEL REQUIRED FOR JACKING, TOWING, HOISTING, GROUND RUN AND FLIGHT.
4	Mark as shown on heat and defroster con trols as shown with aircraft white letters. Letter size indicated in parenthesis	 <p>1. OPEN (3/16 in.) 2. CO-PILOT HEAT (1/8 in.) 3. CLOSED (3/16 in.) 4. ON DEFROST OFF(1/8 in)</p>
5	Paint broken band, MIL-C-46168, orange-yellow, No. 33538, per para 7-24.	
6	Stencil on sound proofing and on structure between first aid kit mounting studs, both sides of helicopter. Letters 1/2-in. aircraft white, cross will be MIL-C-46168, aircraft red, No. 31136 on MIL-C-46168, aircraft white, No. 37875 background.	 <p>FIRST AID KIT 1/2 IN.</p> <p>2 IN. 1/2 IN.</p> <p>2 IN. 1/2 IN.</p>

Figure 9-36. Interior Markings, UH-1D and UH-1H (Sheet 2 of 4)

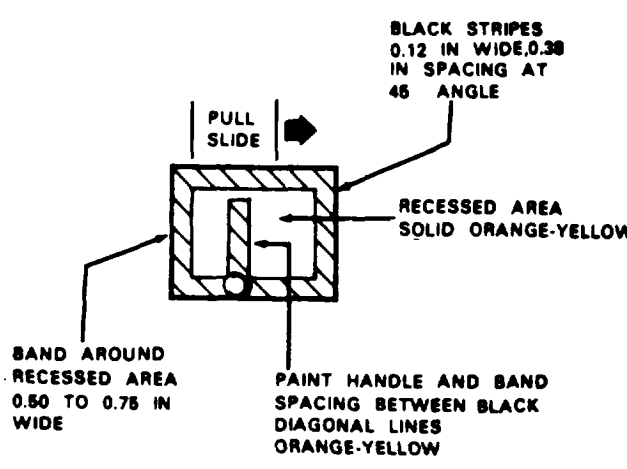
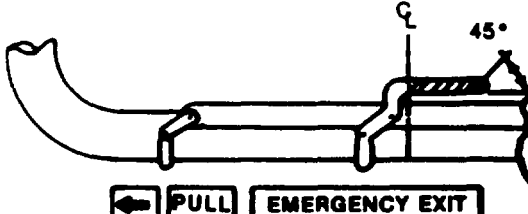

CODE NO.	DIRECTIONS	WORDING
7	Locate on stowage doors both sides of helicopter 1/2-in. aircraft white letters. 4 required.	STOWAGE
8	Paint and stencil both cargo door handles as shown. PULL and SLIDE will be 1-in. aircraft white letters. Arrow is aircraft white 1.5 in. long with 1/2 in. arrow head 1/4 in. shaft.	 <p>Diagram showing a cargo door handle with the following markings and dimensions:</p> <ul style="list-style-type: none"> PULL SLIDE with an arrow pointing right. BLACK STRIPES 0.12 IN WIDE, 0.38 IN SPACING AT 45° ANGLE on the handle. RECESSED AREA SOLID ORANGE-YELLOW on the handle. BAND AROUND RECESSED AREA 0.50 TO 0.75 IN WIDE. PAINT HANDLE AND BAND SPACING BETWEEN BLACK DIAGONAL LINES ORANGE-YELLOW.
9	Cargo door window frames will have the complete periphery from outside edge of panel to inside edge, including stud buttons painted aircraft white. Paint window emergency mechanism dull black with 3/8 in. orange-yellow oblique (45°) stripes, 1/8 in. spacing on inboard surface of handle. Arrow head is 1 in. on a 1/2 in. x 3 in. shaft, EMERGENCY EXIT is 1/2-in. lettering, 4 places.	 <p>Diagram showing a cargo door window frame with the following markings and dimensions:</p> <ul style="list-style-type: none"> EMERGENCY EXIT with a black arrow pointing left. BLACK ARROW & LETTERING ON ORANGE BACKGROUND. 45° angle for the oblique stripes.
10	Located on both sides of fuel access control panel and pylon access panel 1/4 in. MIL-C-46168, aircraft white, No. 37875 letters, 8 required.	STRUCTURAL PANEL REQUIRED FOR JACKING, TOWING, HOISTING, GROUND RUN AND FLIGHT.
11	Locate above cargo door release handles on sound proofing letters 1-in. aircraft white, 2 required.	EXIT RELEASE
12	Locate inside at cabin door handles, 1/2 in. aircraft white letters, arrow, 1/4 in. shaft 1 in. long with 1/2 in. arrow head.	TURN 

Figure 9-36. Interior Markings, UH1D and UH-1H (Sheet 3 of 4)


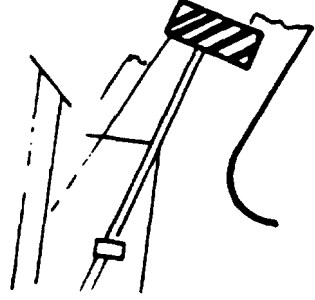
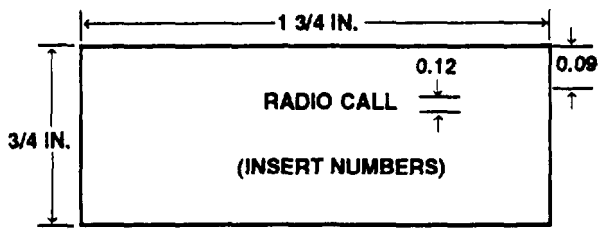
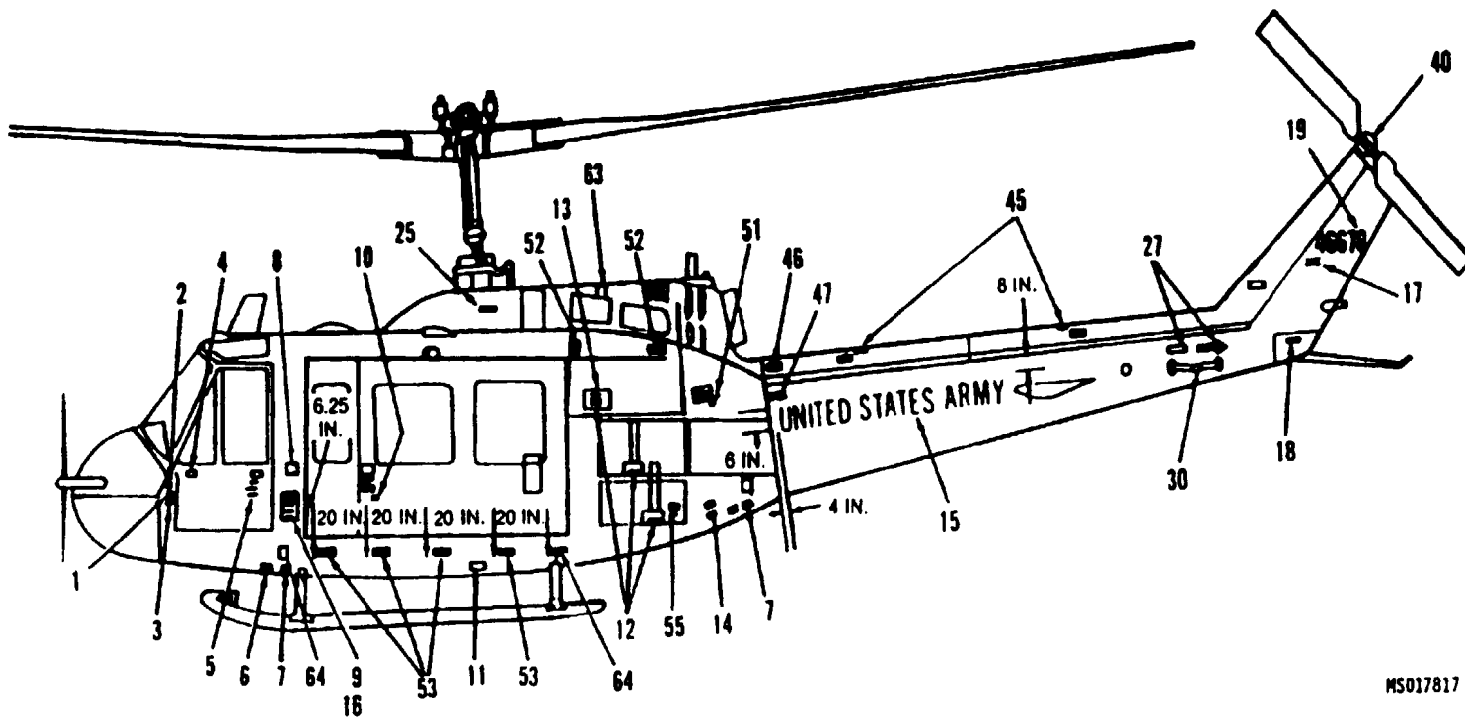
13	Stencil on map case, located at end of center pedestal in 1/2-in. aircraft white letters. If map case is not installed stencil on end of pedestal.	HIGH VOLTAGE
	Stencil inside both cabin doors as shown. Arrow should point to jettison handle. MIL-C-46168, orange-yellow no. 33538 arrow and 1 in. letters.	
15	Paint Jettison handles alternate orange-yellow and black stripes both sides. Refer to paragraph 7-24d.	
16	Paint collective down lock handle aircraft white.	
17	<p>a. Locate on access panels in 1/2-in. white letters.</p> <p>b. Locate on sound proofing flap over access over, 1/2-in. aircraft white letters.</p>	<p>TRANSMISSION OIL LEVEL ACCESS STRUCTURAL PANEL REQUIRED GROUND RUN AND FLIGHT TRANSMISSION OIL LEVEL ACCESS</p>
18	Locate 0.062 inch opaque dull black laminated plastic on top left center of instrument panel with EC-847 cement. Radio call number to be engraved per MIL-M-18012. For field installation radio call number may be engraved or printed in white characters 0.188 to 0.375 in. high.	
19	Both sides of aircraft on diagonal foward portion of door frames with arrow near T-handle to indicate direction of hand motion. 1/2-in., MIL-C-46168, orange-yellow no. 33538 letters and aarows.	EMERGENCY RELEASE - PULL
20	Locate on the center panel of each cockpit door, 1-in., MIL-C-46168, orange-yellow, no. 33538 letters,	EMERGENCY EXIT

Figure 9-36. Interior Markings, UH-1D and UH-1H (Sheet 4 of 4)



MS017817

LEFT SIDE VIEW

Figure 9-37. Exterior Markings, UH-1D and UH-1H (Sheet 1 of 17).

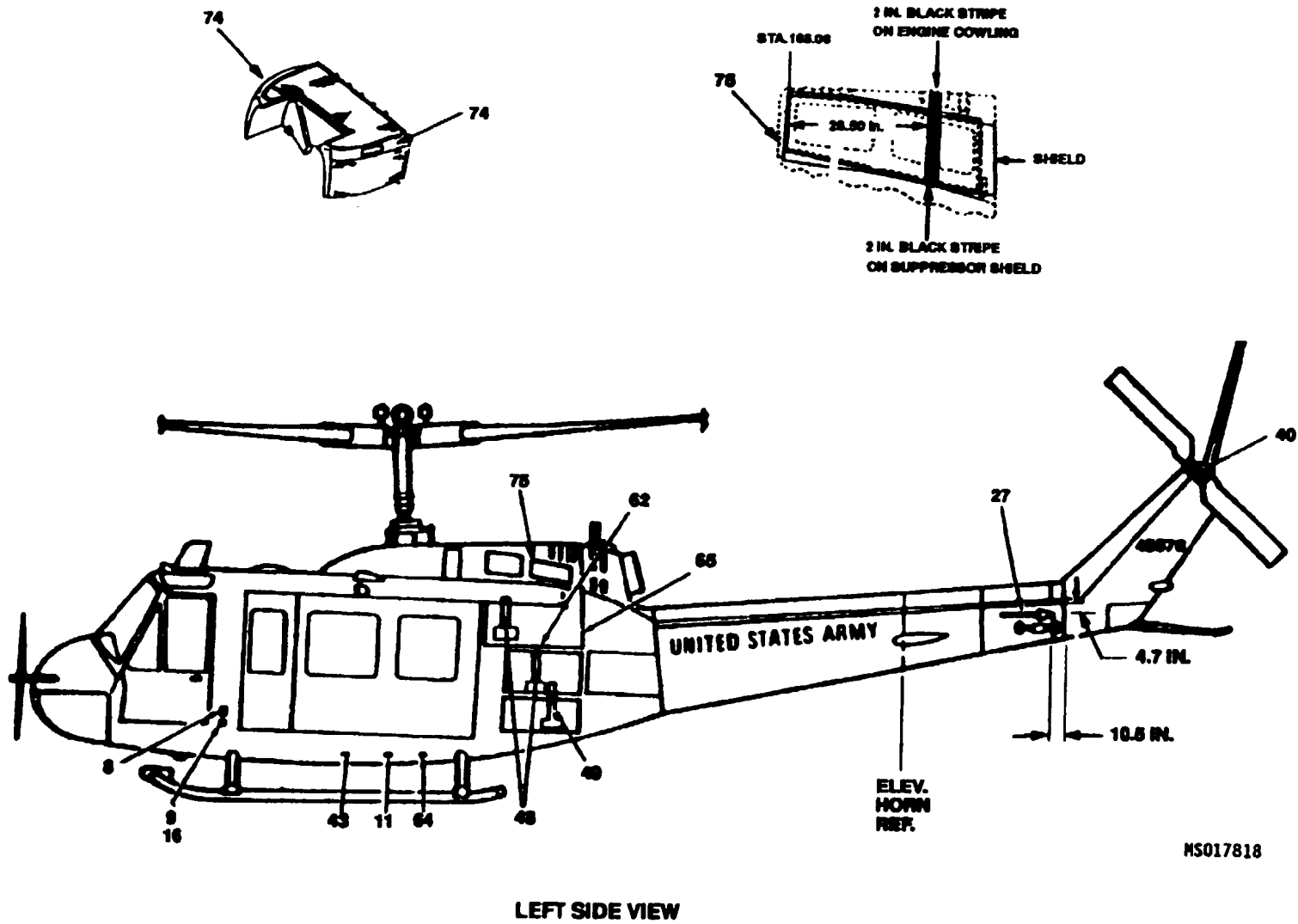
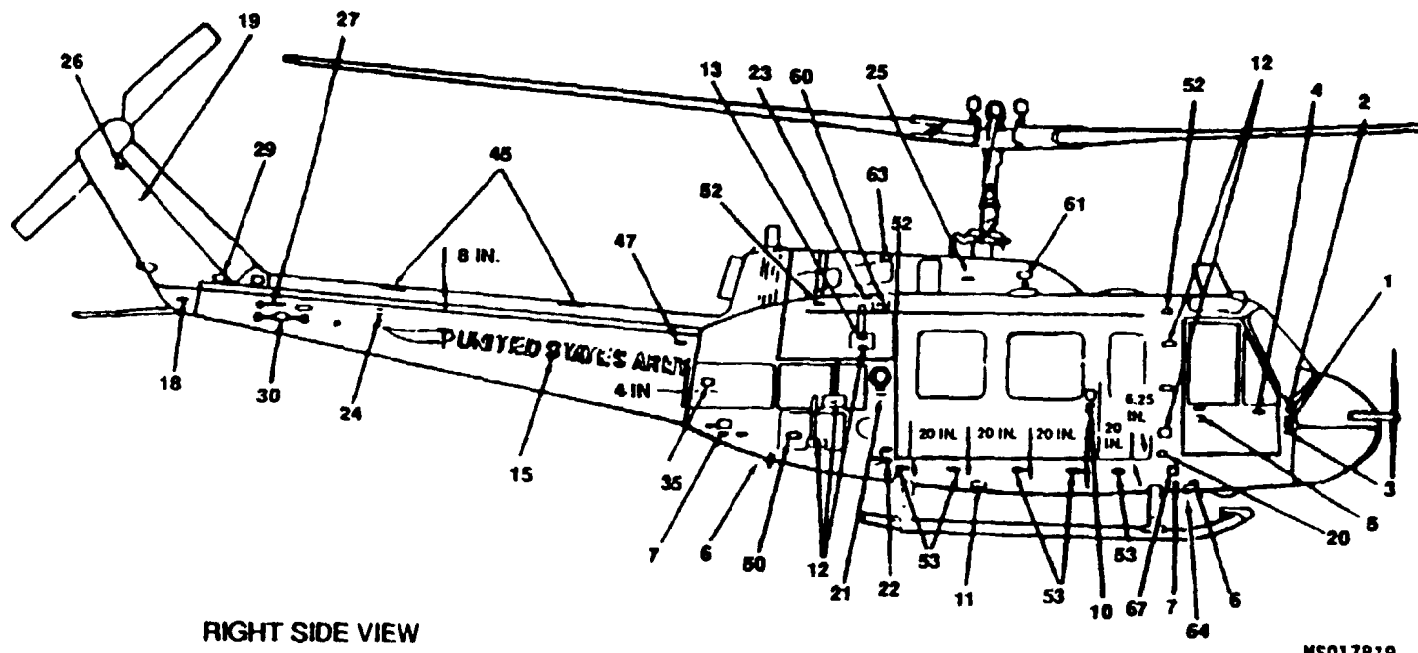


Figure 9-37. Exterior Markings, UH-1D and UH-1H (Sheet 2 of 17).



RIGHT SIDE VIEW

MS017819

Figure 9-37. Exterior Markings, UH-1D and UH-1H (Sheet 3 of 17).

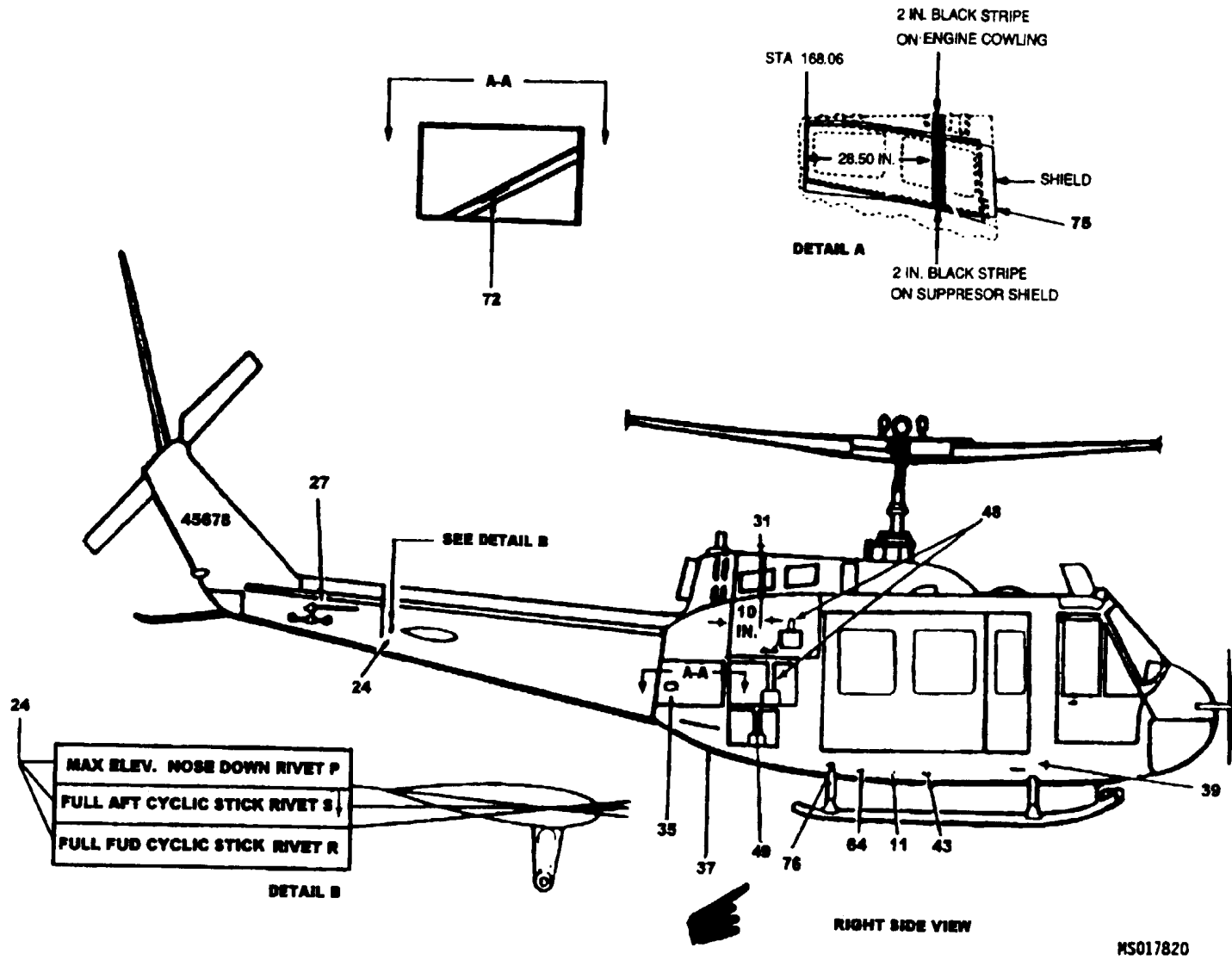
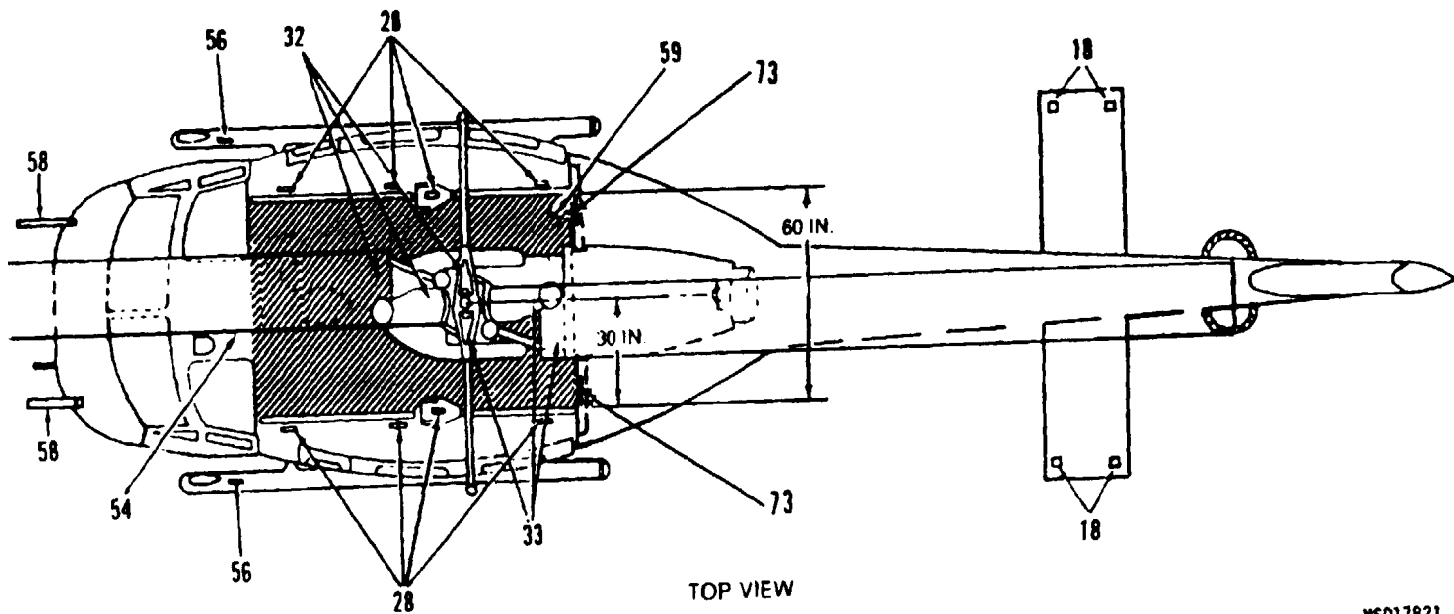


Figure 9-37. Exterior Markings, UH-1D and UH-1H (Sheet 4 of 17).



MS017821

Figure 9-37. Exterior Markings, UH-1D and UH-1H (Sheet 5 of 17)

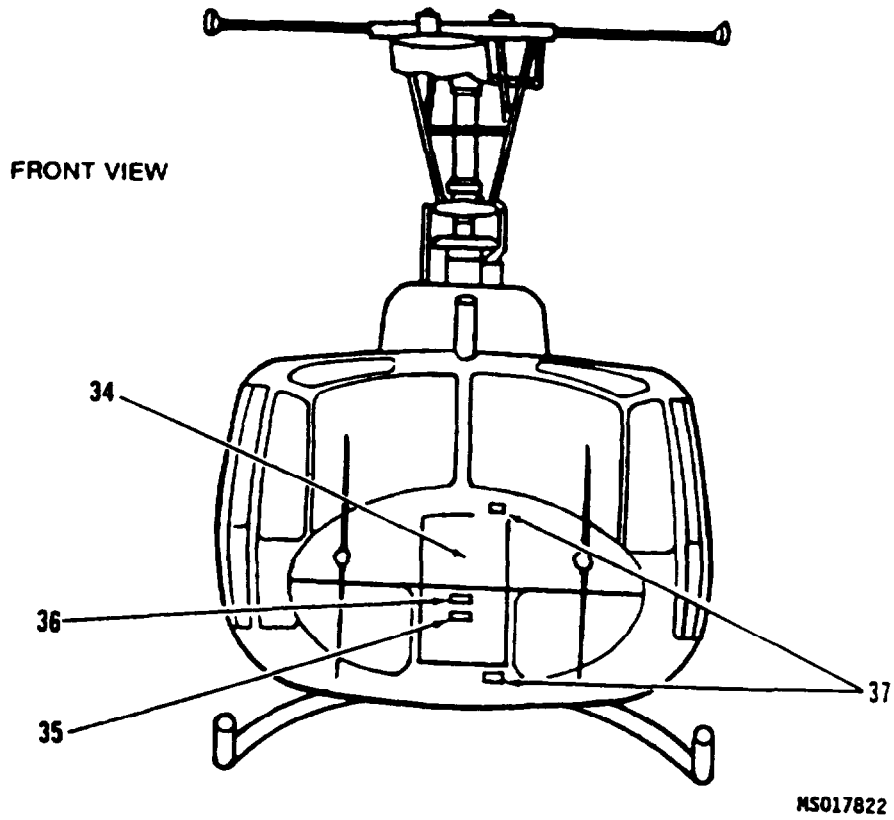


Figure 9-37. Exterior Markings, UH-1D and UH-1H (Sheet 6 of 17)

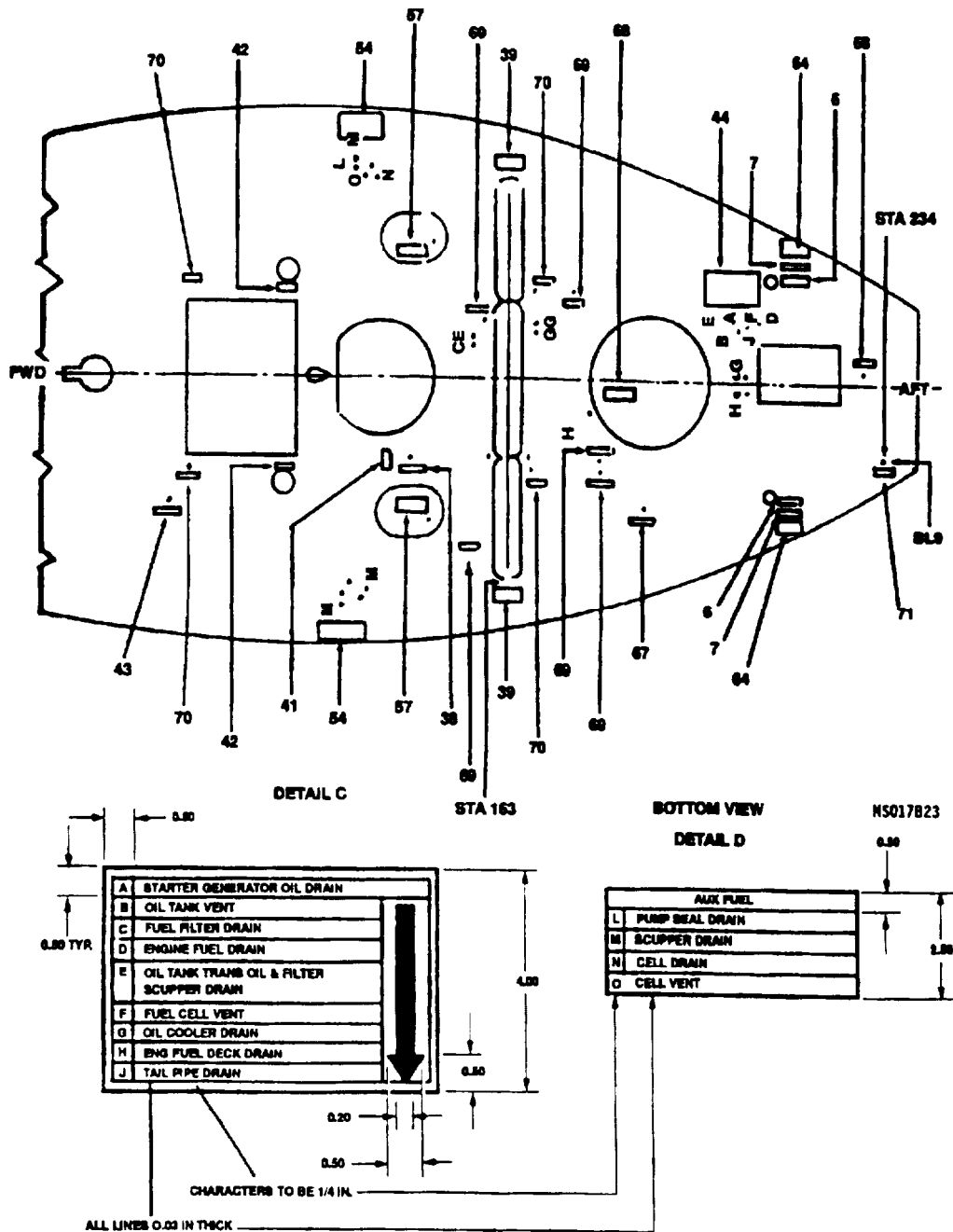


Figure 9-37. Exterior Markings, UH-1D and UH-1H (Sheet 7 of 17)




CODE NO.	DIRECTIONS	WORDING
1	<p>Both sides of aircraft. A circular 3/8 in. MIL-C-46168, aircraft black, No. 37038, broken band. inside diameter is 2-1/4 in.</p> <p>NOTE</p> <p>Applicable to aircraft equipped with static port.</p>	
2	<p>Both sides of aircraft. 1/4-in. black letters located above broken circle.</p> <p>NOTE</p> <p>Applicable to aircraft equipped with static port.</p>	DO NOT PLUG OR DEFORM HOLES
3	<p>Both sides of aircraft, 1/4-in. black letters located above broken circle.</p> <p>NOTE</p> <p>Applicable to aircraft equipped with static port.</p>	STATIC PORT
4	<p>Both sides of aircraft. Forward side of cockpit door. 1/2-in. black letters.</p>	JETTISON HANDLE INSIDE
5	<p>Both sides of aircraft. Under cockpit handle. 1-in. black letters with arrows. Arrows to point down.</p>	<p>TURN</p>  <p>PULL</p>
6	<p>Both sides of aircraft, 1/2-in. black letters. Forward of front skid cross tube at fitting with arrow. Also, aft end of fuselage, both sides.</p>	<p>JACK HERE</p> 
7	<p>Both sides of aircraft. Forward of front skin cross tube aft fitting. Also, aft end of fuselage, both sides. 1/2-in. black letters.</p>	MOOR

Figure 9-37. Exterior Markings, UH-1D and UH-1H (Sheet 8 of 17)


CODE NO.	DIRECTIONS	WORDING
8	Left side of aircraft between doors in fuselage. Top four lines are 1-in. black letters, remainder are 1/2-in. black letters.	U.S. ARMY (insert model UH-1H, UH-1V) U.S.A. SERIAL NO. (INSERT SERIAL NO.) SERVICE THIS AIRCRAFT WITH MIL-T-83133 GRADE JP-8 AVIATION FUEL IF NOT AVAILABLE REFER TO TB-55-9150-200-24 FOR ALTERNATE FUEL
9	Left side of aircraft under code No. 8, 1/4-in. black letters * * Contractor will insert their name code.	* * WP1-P2-L3 Date WP - Indicate wash primer used P - Indicate primer used L - Indicate Lacquer used (if req'd) C - Indicate coating used (if req'd)
10	Both sides of aircraft under main cabin door handle, 1-in. black letters with arrows.	TURN SLIDE 
11	Both sides of aircraft below cabin door and also aft of hook opening in lower skin, 1-1/4 in. black letters.	CARGO HOOK MAX LOAD 4000 LBS.
12	Both sides of aircraft on each fuselage kick-in step, 1/2-in. black letters. Also, two kick-in steps forward of right cabin door.	STEP
13	Both sides of fuselage on top forward kick-in step, above word "STEP". 1/2 inch black letters.	ACCESS FOR FIRE EXTINGUISHER
14	On external power door, left side of fuselage, 1/2-in. black letters	28V D.C.
15	Both sides of Aircraft. Most forward letter (U-left side, Y-right side) to start 4.0 in. aft of tailboom joint. Top of letters are 8.0 in. down from parallel to top skin seam. Letters to be 6 in. high lusterless black. Additional dimensions and spacing in accordance with Fig. 8-2.	UNITED STATES ARMY

Figure 9-37. Exterior Markings, UH-1D and UH-1H (Sheet 9 of 17)

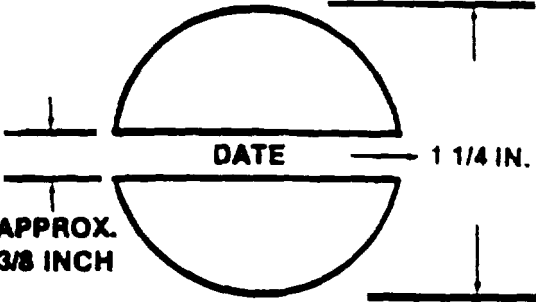


CODE NO.	DIRECTIONS	WORDING
16	Stencil below code No. 9. NOTE Date shown on stencil is date aircraft painted with MIL-C-46168 paint.	
17	Aft of fitting on fwd center pylon, 1/4-in. black letters.	TAIL ROTOR TIE DOWN
18	On fiberglass tail cone top, both sides, 1/2-in. black letters. Also top of elevator, 4 places.	NO PUSH
19	On both sides of vertical fin, five 6-in. high black numerals, 17 in. above tail boom upper surface. Numbers are to be in a horizontal line. NOTE Add O-at front of call number for aircraft more than 10 years old.	(Radio call numbers)
20	Right side of fuselage aft of cockpit door and fwd cabin door lower side of center post with armored seats installed. Arrow to point aft when extinguisher is installed on cargo floor between pilots seats. 1/2-in. black letters.	HAND FIRE EXTINGUISHER INSIDE 
21	Insert fuel capacity for aircraft. All letters and numbers 1/2 in. black letters.	CAP. U.S. GAL. USE MIL-T-83133 GRADE JP-8 IF NOT AVAILABLE REFER TO TB 55-9150-200-24 FOR ALTERNATE FUEL
22	Paint a black ground symbol, shade 37038, dimensions per MIL-C-83413/9-2.	

Figure 9-37. Exterior Markings, UH-1D and UH-1H (Sheet 10 of 17)

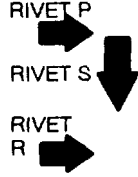
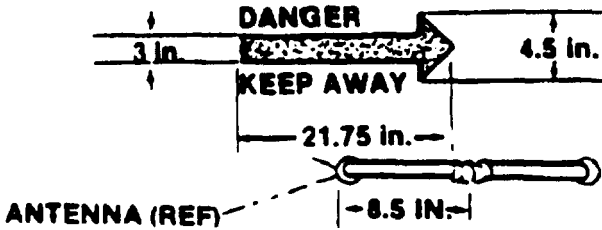
CODE NO.	DIRECTIONS	WORDING
23	Right side of aircraft above and forward of kick-in door. Check existing stencil before stripping 1/2-in. black letters.	ENGINE OIL TANK INSIDE MIL-L-23699 OIL ABOVE -25°F MIL-L-7808 OIL BELOW -25°F
24	<p>a. Right side of tailboom AFT of elevator. 1/4 inch letters "Rivet P". Arrow 1/8 inch shaft length of word "Rivet P". Paint rivet head same color as adjacent surface. The arrow will point to the specific rivet for travel.</p> <p>b. Right side of tail boom AFT of elevator. 1/4 inch letters "Rivet s". Arrow 1/2 inch 1/8 inch shaft, pointing down. Paint rivet head same color as adjacent surface. the arrow will point to the specific rivet for travel.</p> <p>c. Right side of tailboom, AFT of elevator. 1/4 inch letters "Rivet R". Arrow 1/8 inch shaft, length of word "Rivet R". Paint rivet head same color as adjacent surface. The arrow will point to the specific rivet for travel.</p>	<p>MAX. ELEV. NOSE DOWN</p> <p>FULL AFT CYCLIC STICK</p> <p>FULL FWD CYCLIC STICK</p> 
25	Both sides of main rotor fairing 1/2-in. black letters.	TRANSMISSION OIL ACCESS MIL-L-23699 OIL ABOVE -25°F MIL-L-7808 OIL BELOW -25°F
26	Top right of pylon 1/2-in. black letters, Check existing stencil before stripping.	SERVICE GEAR BOX WITH MIL-L-23699 OIL ABOVE -25°F MIL-L-7808 OIL BELOW -25°F
27	Tail rotor warning, black arrow 3 in. wide, 21.75 in. long including 4 x 4-1/2 in. arrow head. Locate arrow 4 in. above parallel with centerline of antenna extending 8.5 in. past forward end of antenna mount. 1-3/4 in. black letters.	
28	Apply "NO STEP" four places on each side facing away from walkway area.	NO STEP
29	Right side of tail, boom aft of 42° gear box cover. 1/2-in. black letters.	REMOVE TO SERVICE WITH MIL-L-23699 ABOVE -25° F MIL-L-7808 BELOW -25° F
30	On each side of tail boom stencil NO PUSH 1/2-in. black letters on bend of antenna tubing, 4 required.	NO PUSH
31	Paint a 2 in. black stripe over top of cowling to show turbine wheel location 10 in. forward from rear cowling.	

Figure 9-37. Exterior Markings, UH-1D and UH-1H (Sheet 11 of 17)

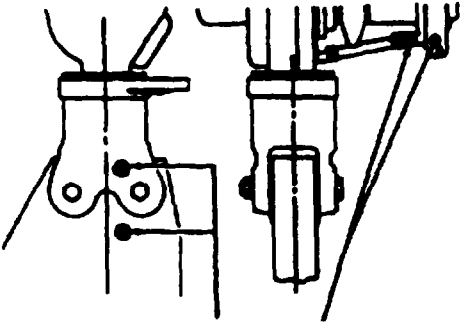
CODE NO.	DIRECTIONS	WORDING
32	A 1/2-in. diameter red dot on pitch horn and on upper and lower surface of blade and grip and attaching linkage.	
33	A 1/2 in. diameter white dot on pitch horn and on upper and lower surface of blade and grip and attaching linkage.	
34	Authorized placement of unit insignia is on the nose access panel.	
35	Right side center, oil cooler compartment access door or nose aircraft center of avionics compartment cover, depending on aircraft configuration. 1/2-in. black letters.	BATTERY ACCESS
36	Nose of aircraft on access door, 1/2-in. black letters.	RADIO ACCESS
37	Two places on nose of helicopter at battery vents. 1/2 in. black letters.	BATTERY VENT
38	Bottom of fuselage, left side, top of letters to aircraft centerline. 1/2-in. black letters.	HYD PUMP DRAIN
39	Locate on both sides of fuselage directly above front cross tube, 1/4 in. black letters	<p>CROSS TUBE MOORING LOAD NOT TO EXCEED FWD 2600 LBS VERT DN 5000 LBS FORE & AFT</p>
40	Tail rotor control markings will be with 1/2-in. dots located in conspicuous place on each part. Colors red and white. One side shown, opposite side of assembly will have 1/2-in. white dots in the same location.	 <p>1/2 IN. RED DOT</p>

Figure 9-37. Exterior Markings, UH-1D and UH-1H (Sheet 12 of 17)

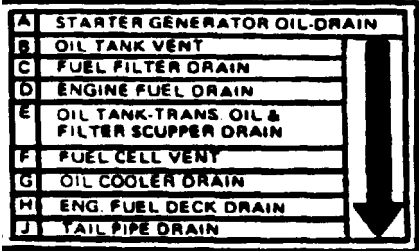
CODE NO.	DIRECTIONS	WORDING
41	Bottom right side of fuselage, left side, top of letters to aircraft centerline, 1/2-in. black letters.	HYD RESERVOIR SCUPPER DRAIN
42	Bottom of fuselage, left and right side, top of fetters to aircraft centerline, 1/2-in. black letters	FWD SUMP DRAIN
43	Bottom right side of fuselage, top of letters to aircraft centerline, 1/2-in. black letters.	HEATER FUEL PUMP DRAIN
44	Locate left bottom side of fuselage above multiple drain and vents. With mounted decal locate 1/4-in. black letters "A" thru "J" at drain and vent locations, see detail C.	
45	Deleted	
46	Left fwd side of tail rotor drive shaft housing, 1/2-in. black letters.	MOD PLATE INSIDE
47	Left and right side of fwd tail boom, aft of mounting hole, 1/2-in. black letters.	COWL LATCH
48	Center kick-in door. Paint 1 in. wide, approximately 10 in. long black stripe up to the door track and centered on top of the kick-in door, both sides of aircraft. Top kick-in door. Paint 1 in. wide, 12 in. long black stripe centered on the trop of the kick-in door, both sides of aircraft.	
49	Paint 1 in. wide, 16 in. long black stripe centered on top of the kick-in door, both sides of aircraft	
50	Right side of aircraft aft of lower step stripe, 1/2-in. black letters.	HEATER ACCESS

Figure 9-37. Exterior Markings, UH-1D and UH-1H (Sheet 13 of 17)

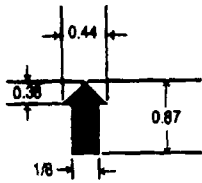
CODE NO.	DIRECTIONS	WORDING
51	Left side of aircraft below access door, 1/2-in. black letters.	ELECTRICAL DISCONNECT ACCESS
52	Both sides of aircraft on cowling below hand hold location. Inside engine cowling on forward bulkhead, locate near grab handle, both sides. 1/2-in. black letters.	HAND HOLD
53	Both sides of aircraft below row of rivets under cabin doors 1/2-in. black letters with arrows. Arrows to be centered on exact fuselage station. First arrow, station 80, is 6-1/4 in. aft of fwd cabin door frame. Other station markings are 20 in. apart.	<p> STA 80 ↑ STA 100 ↑ STA 120 ↑ STA 140 ↑ STA 160 ↑ </p> 
54	Bottom of fuselage above auxiliary fuel drain and vents, both sides, see detail. Place decal letters adjacent to auxiliary fuel system fittings as shown in detail D. 1/2-in. black letters.	AUX FUEL L-PUMP SEAL DRAIN M-SCUPPER SEAL DRAIN N-CELL DRAIN O-CELL VENT
55	Left side of aircraft above external power connection door 1/2-in. black letters with arrow.	EXTERNAL POWER ↓
56	On upper center of tube above tow ring, 1/2 in. black letters.	TOW
57	Locate on panel, both sides, top of letters to aircraft centerline. 1/2-in. black letters.	FUEL PUMP ACCESS and SUMP DRAIN
58	Inboard and outboard sides of FM homing antenna mounts, 1/2-in. black letters.	NO PUSH
59	Walkway area on top of fuselage will be painted with non-slip material MIL-W-5044. Overcoat with MIL-C-46168 to match existing color scheme.	

Figure 9-37. Exterior Markings, UH-1D and UH-1H (Sheet 14 of 17)

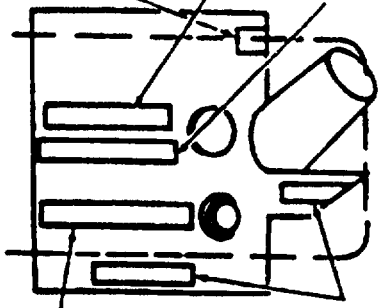
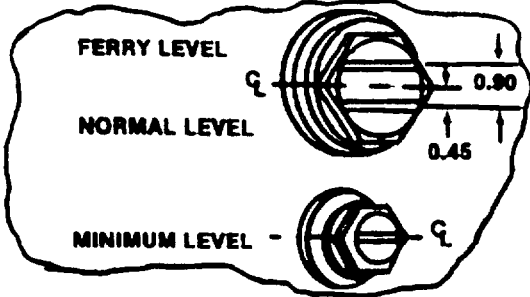
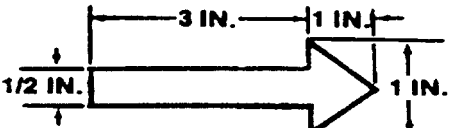
CODE NO.	DIRECTIONS	WORDING
60	<p>a. Stencil engine oil tank with 1/4-in. orange-yellow letters as shown. NO STEP is located on top of reservoir, and OIL RESERVOIR is located near top of tank and centered behind filler neck. All other markings are as indicated.</p> <p>b. Paint 1/16 in. orange-yellow lines on OIL RESERVOIR sight gauges as shown.</p>	<p>OIL RESERVOIR NO STEP MIL-L-23889 ABOVE - 25°F MIL-L-7808 BELOW - 25°F OIL FERRY LEVEL OIL NORMAL LEVEL</p>  <p>MINIMUM OIL LEVEL NO HAND HOLD (2)</p> 
61	<p>Locate aft of reservoir sight gauge on right side pylon cover, 1/2-in. black letters.</p>	<p>HYDRAULIC RESERVOIR INSIDE WHEN FLUID LEVEL IS VISIBLE FILL TO OVERFLOW</p>
62	<p>Paint black arrows on both sides of engine work deck painting to black step stripes, see code No. 48.</p>	
63	<p>Stencil inside upper engine cowl both sides to read correctly when cowl is in open position, 1/2-in. black letters.</p>	<p>CLOSE THIS COWL FIRST</p>
64	<p>Locate adjacent to mooring points, 4 required, 1/4-in. black letters.</p>	<p>TIE DOWN RING MOORING LOAD ON RING NOT TO EXCEED 1000 LBS VERTICALLY 500 LBS LATERALLY 500 LBS FWD/AFT</p>

Figure 9-37. Exterior Markings, UH-1 D and UH-1 H (Sheet 15 of 17)


CODE NO.	DIRECTIONS	WORDING
65	UH-1D. Locate decal on aft side of station 166 bulkhead above the 204-060-499 bracket, 1/2-in. black letters.	<p style="text-align: center;">WARNING</p> INSTALL 204-060-494-1 FITTING IN TURBO FAN INLET HOUSING AND 205-060-494-1 FITTING IN BLEED AIR HEATER VALVE OUTLET WITH T53-L-9A OR T53-L-11 ENGINE INSTALLATION.
66	Bottom right side of fuselage, top of letters to aircraft centerline, 1/2-in. black letters.	OIL TANK VENT
67	Bottom right side of fuselage, top of letters to aircraft centerline, 1/2-in. black letters.	HEATER DRAIN
68	Bottom sides of access panel aft of rear cross tube, 1/4-in. MIL-C-46168, aircraft black, no. 37038 letters.	STRUCTURAL PANEL REQUIRED FOR JACKING, TOWING, HOISTING, GROUND RUN AND FLIGHT.
69	Bottom of fuselage, left and right side, top of letters to aircraft centerline, 4 required, 1/2-in. black letters.	FUEL CELL DRAIN
70	Bottom of fuselage, left and right side, top of letters to aircraft centerline, 4 required, 1/2-in. black letters.	FUEL CELL CAVITY DRAIN & VENT
71	1/2-in. black letters on vents, 2 places.	BATTERY VENT
72	Locate on structural tube (P/N 205-030-249-9) right hand side of fuselage between WL 36 and 55, and between station 211 and 243. 1/4-in. orange-yellow letters.	STRUCTURAL TUBE REQUIRED FOR GROUND RUNG AND FLIGHT
73	Apply "No step" to center of cowling supports (P/N 205-030-407-41/-42) on each side facing away from walkway area. 1-1/2 inch black letters.	NO STEP
74	Stencil "No Step" on improved particle separator, upper half, 1/2 in. MIL-C-46168, Aircraft black No. 37038 letters, 2 places	NO STEP
75	Exhaust heat suppressor kit (P/N 205-706-082-1) LH and RH side shields, 2 in. black stripe to show turbine wheel locations as shown in detail A	2 IN. 

Figure 9-37. Exterior Markings, UH-10 and UH-1H (Sheet 16 of 17)

CODE NO.	DIRECTIONS	WORDING
76	Locate on both sides of fuselage directly above rear cross tube, 1/4-in. black letters.	CROSS TUBE MOORING LOAD NOT TO EXCEED AFT 3500 LBS VERT DN 5000 LBS FORE & AFT

Figure 9-37. Exterior Markings, UH-1D and UH-1H (Sheet 17 of 17)

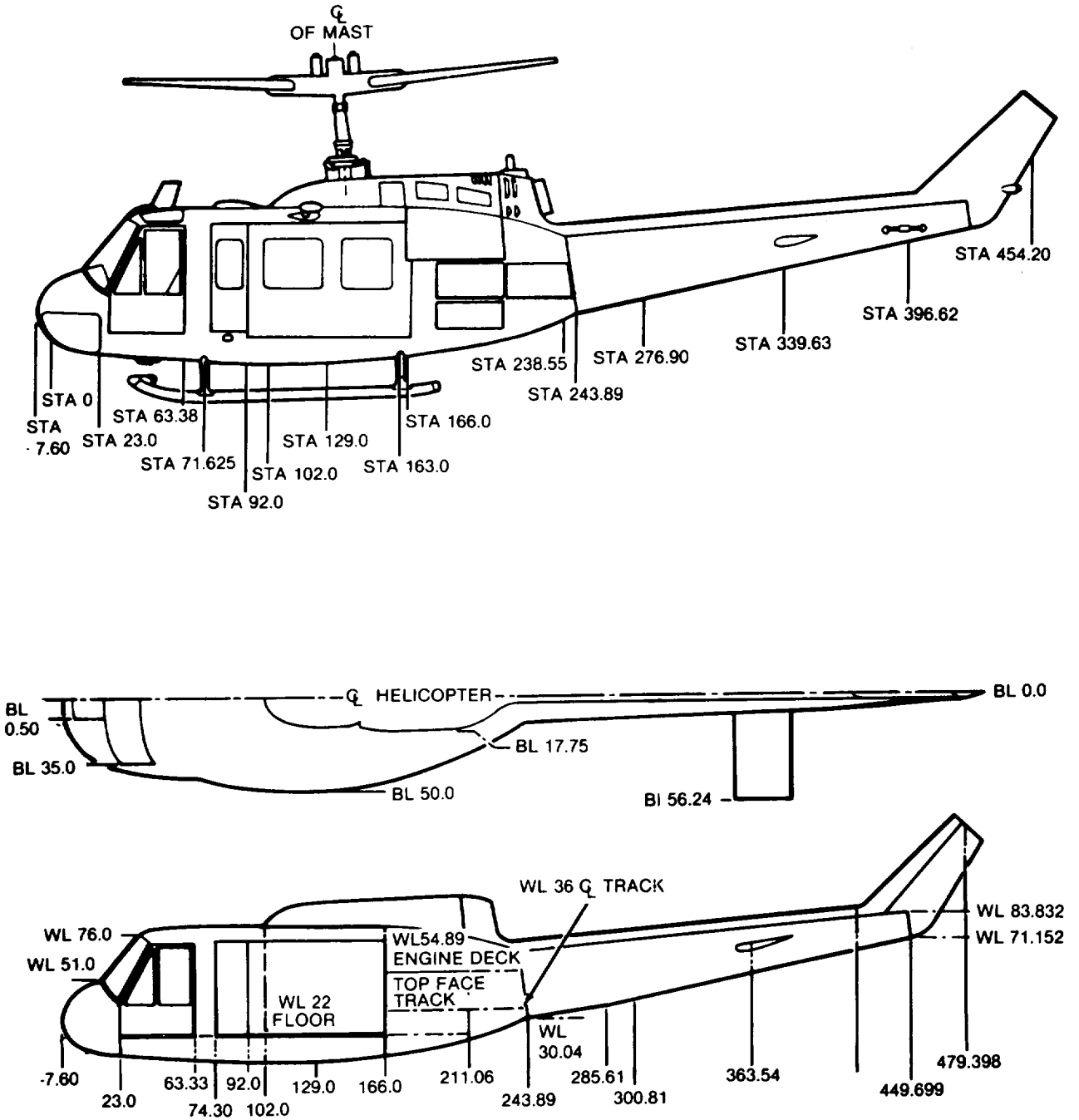
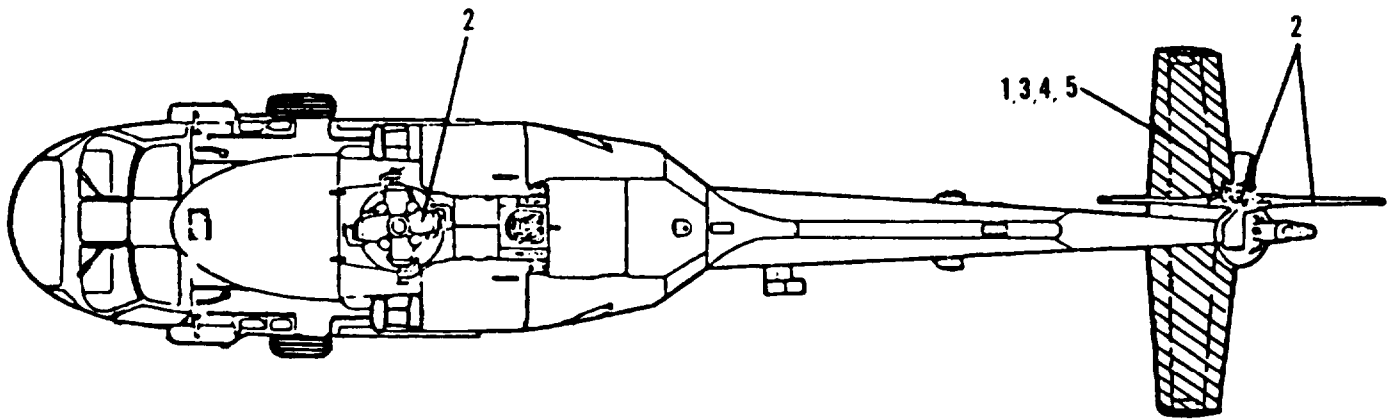
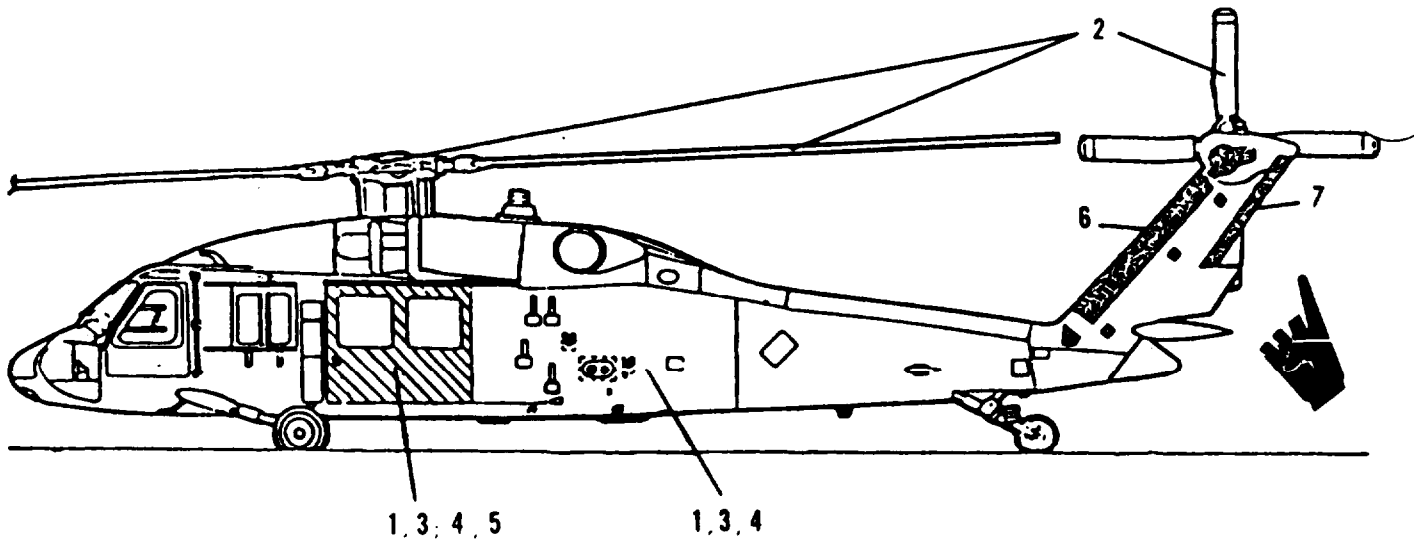


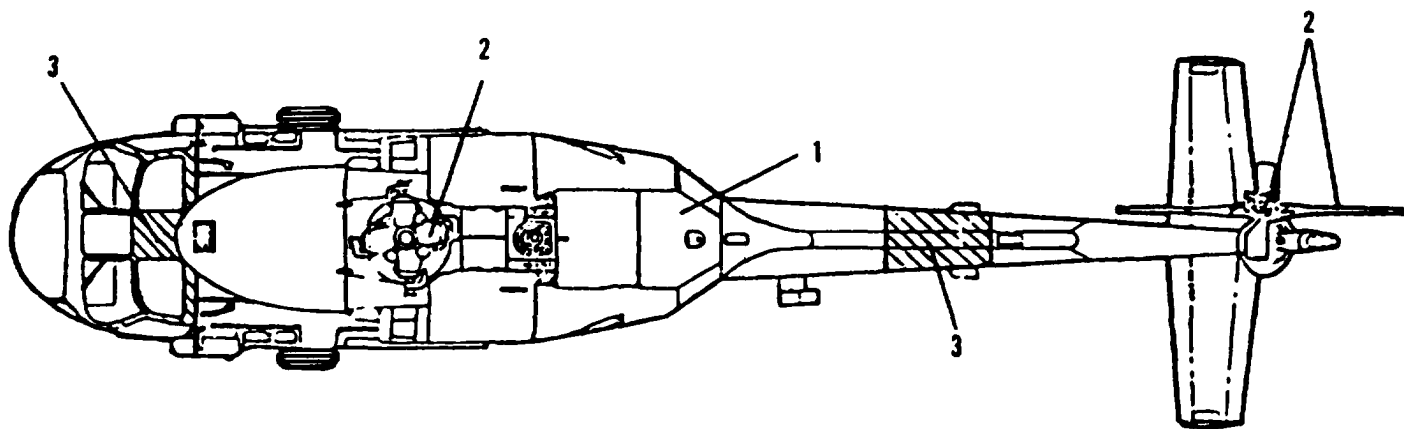
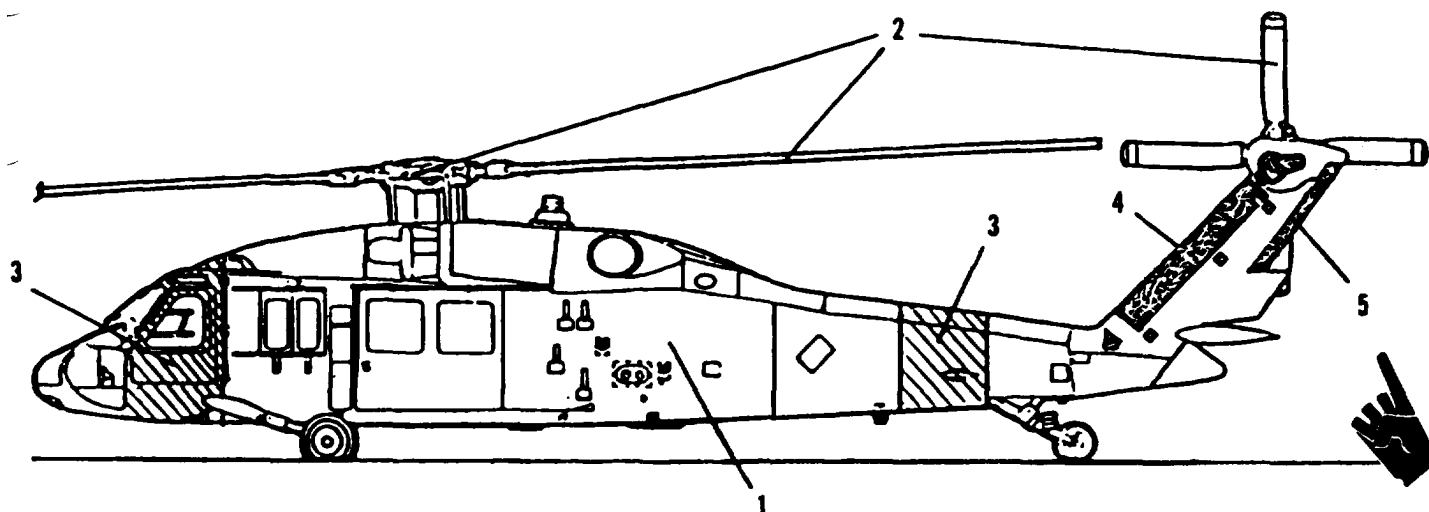
Figure 9-38. Station Diagram, UH-1D and UH-1H

Section IX. UH-60 ILLUSTRATIONS



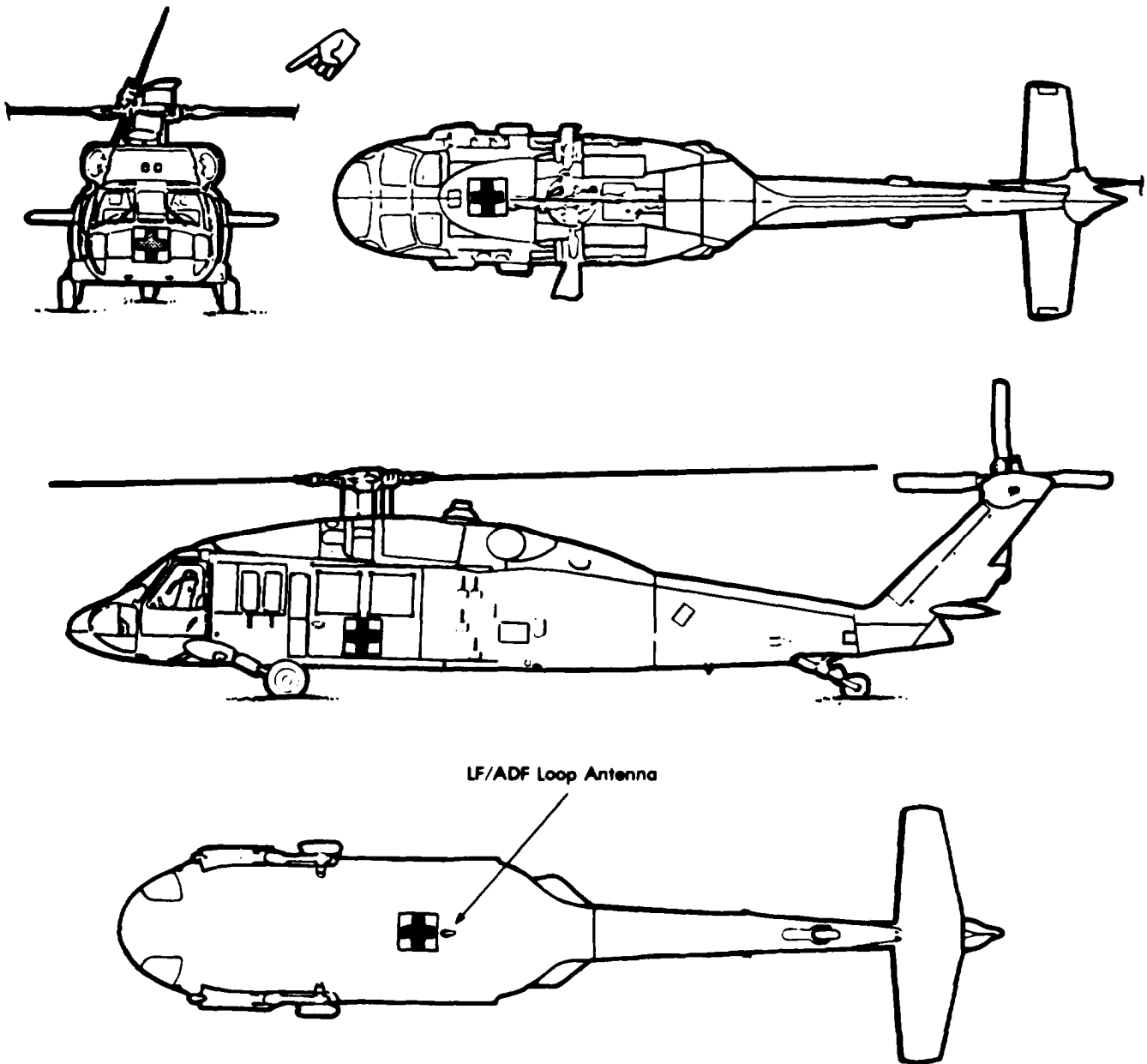
1. MIL-C-46168, Aircraft Green (entire aircraft, except as noted).
2. MIL-C-46168, Aircraft Black.
3. MIL-C-46168, Dark Sand (entire aircraft or high conspicuous paint scheme when authorized, desert operations only). See Paragraph 5-11.
4. MIL-C-46168, Aircraft White (entire aircraft or high conspicuous paint scheme when authorized, arctic operations only). See Paragraph 5-11.
5. MIL-P-21600, Fluorescent Red-Orange. ANA #633 (training aircraft-high visibility, only where authorized).
6. MIL-C-83231, CLA TY2, Coating, Rain Erosion Resistant.
7. Do not paint.

Figure 9-39. Tactical Paint Scheme, UH-60



1. MIL-C-46168, aircraft green (entire aircraft, except where noted).
2. MIL-C-46168, aircraft black.
3. MIL-P-21600, fluorescent red-orange, ANA #633 (shaded areas only).
4. MIL-C-83231, CLA TY2, Coating, Rain Erosion Resistant.
5. Do not paint

Figure 9-40. Non-Tactical Arctic/Desert Paint Scheme, UH-60



NOTES

1. Fuselage: Some as tactical paint scheme.
2. National insignia: None
3. Red crosses: Size and location approximately as shown
4. Command and Organizational Insignia:
Optional position for Air Ambulance only.

Figure 9-41- Army Medical Service (Ambulance), UH-60

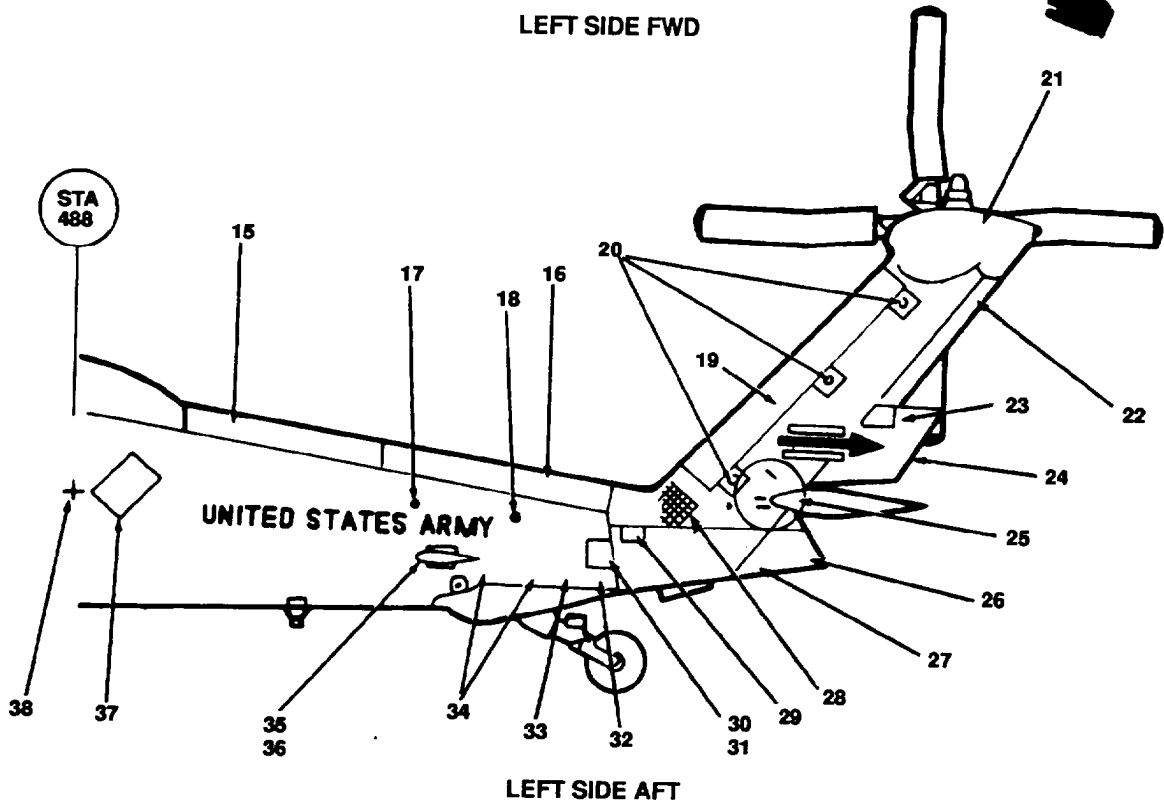
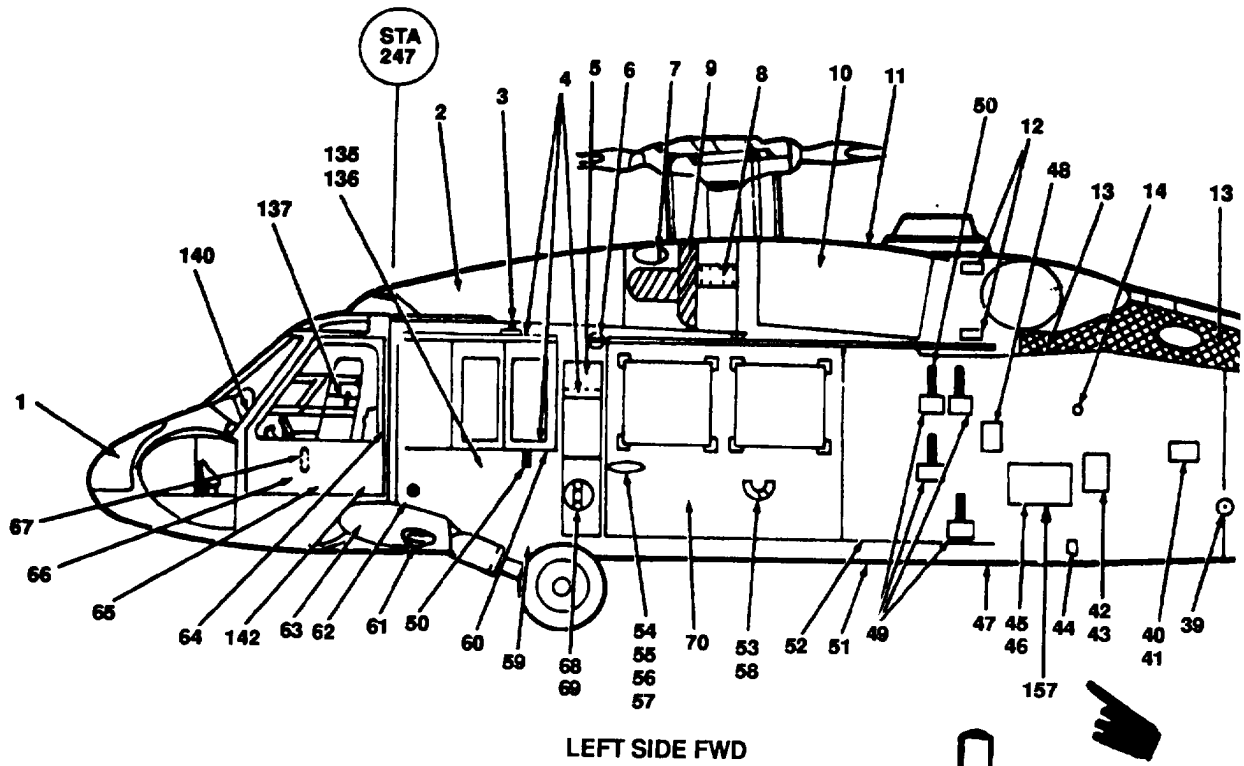


Figure 9-42. Exterior and Interior Markings, UH-60 (Sheet 1 of 20).

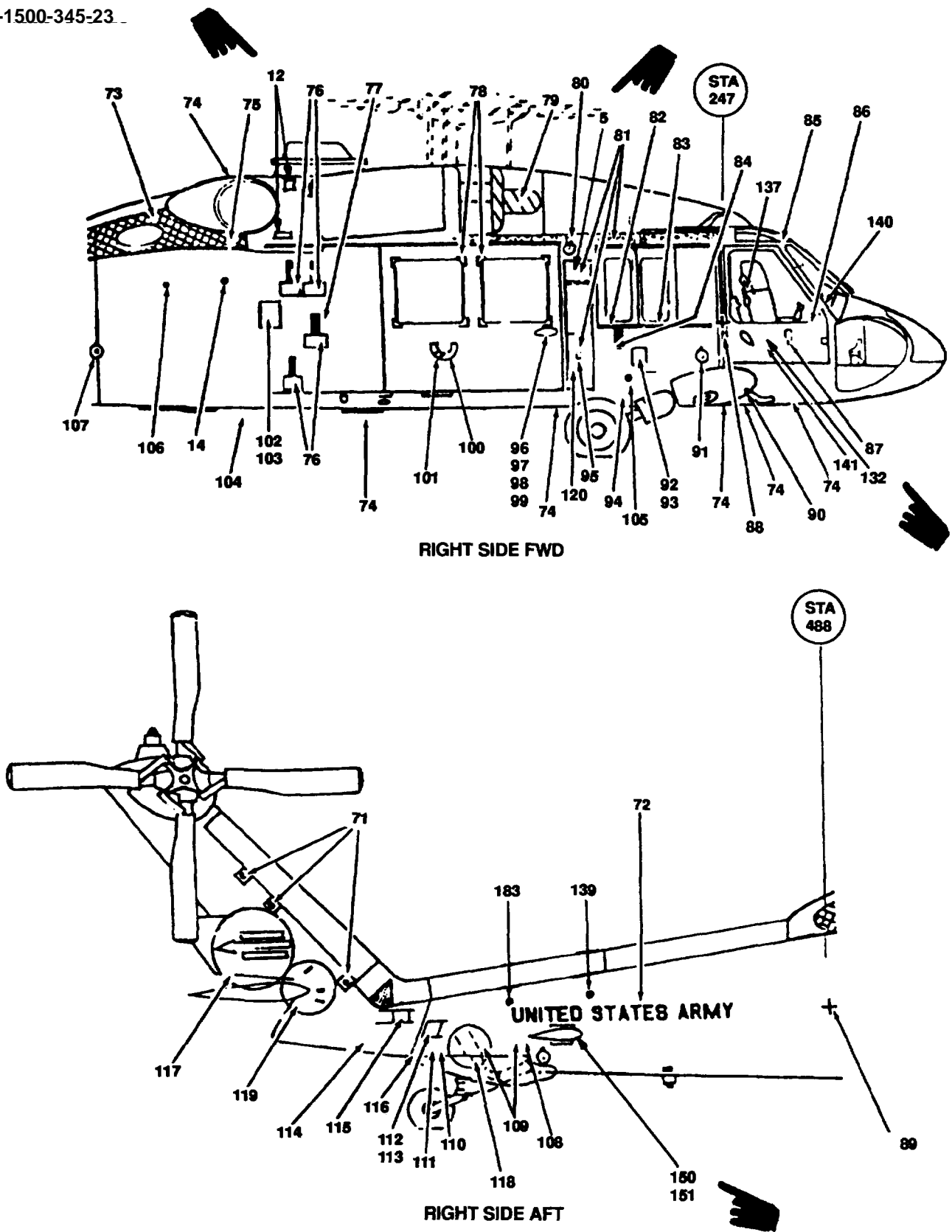


Figure 9-42. Exterior and Interior Markings, UH-60 (Sheet 2 of 20).

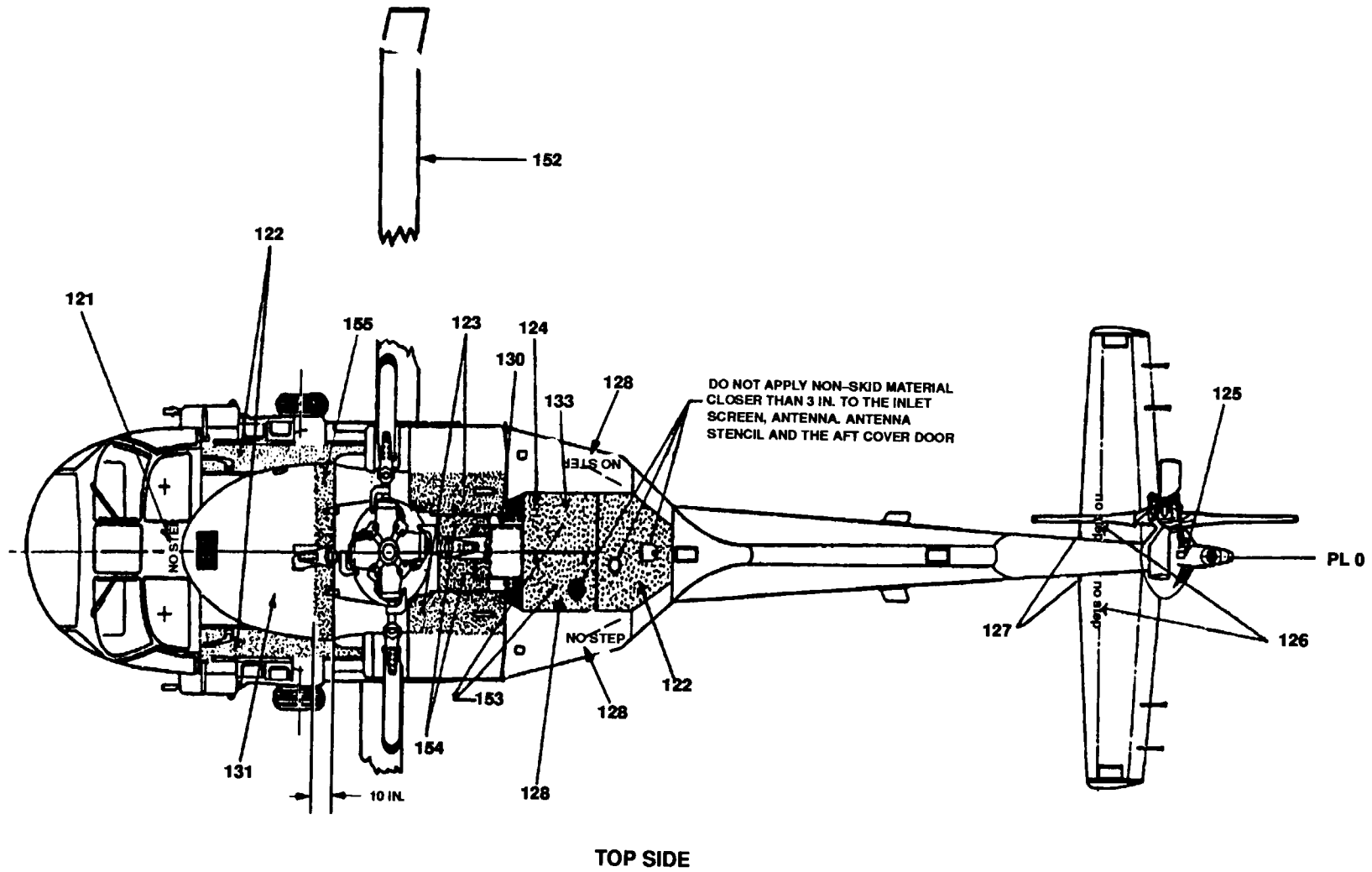
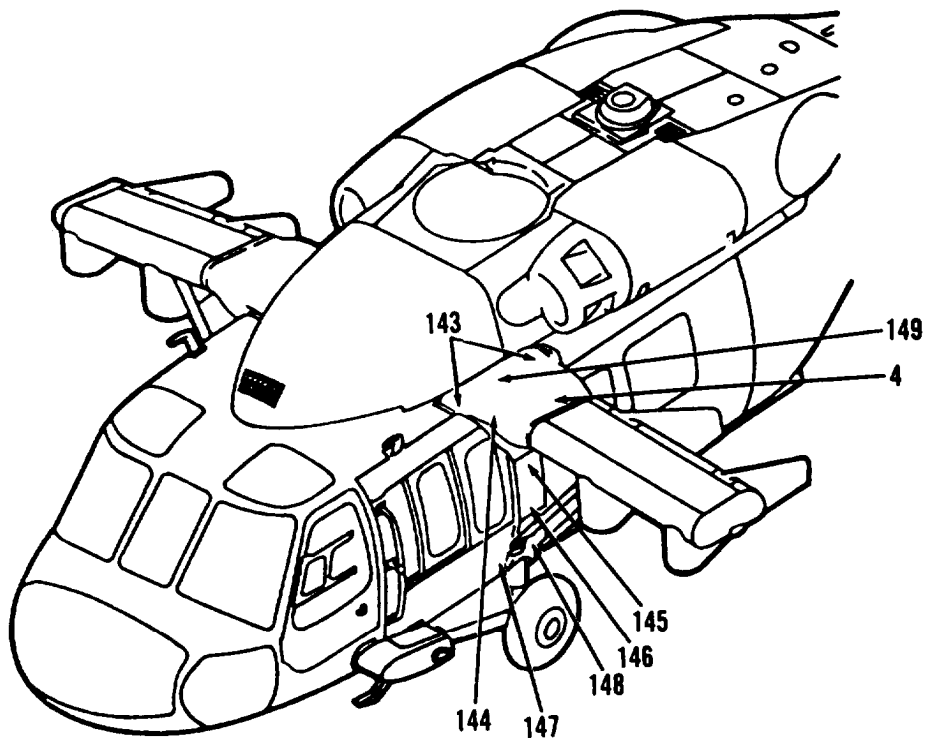


Figure 9-42. Exterior and Interior Markings. UH-60 (Sheet 3 of 20).



ESSS PECULIAR STENCILS

Figure 9-42. Exterior and Interior Markings, UH-60(Sheet 4 of 20)


CODE NO.	DIRECTIONS	WORDING
1	Top surface of access panel (nose door electronics, hinged) 1/2-in. MIL-C-46168, aircraft black, No. 37038, letters.	1B-2B-1
2	Top surface of sliding fairing, M.R.P. controls and accessories, 1/2-in. aircraft black letters.	3T-4T-2
3	Above gunners window, 1/2-in. aircraft black letters.	HAND HOLD
4	Apply non-skid coating to all walkways, steps, and platforms, MIL-W-5044, Type II, paint aircraft black. NOTE: Step area of gunners window sill, paint MIL-C-46168, aircraft interior grey, No. 36231.	
5	Place stencil on air-oil strut access panel and above on fuselage. NOTE: Do not apply this stencil on aircraft provisioned for ESSS.	3T-3 LH side 4T-4 RH side
6	Above and fwd of cargo door FS 308, WL 261, 1/2-in. aircraft black letters.	<div style="display: flex; align-items: center; justify-content: center;"> <div style="font-size: 48pt; margin-right: 20px;">2</div> <div style="text-align: center;"> <p>HOIST POINT TIE DOWN</p> </div> <div style="font-size: 48pt; margin-left: 20px;"></div> </div>
7	Inlet fairing LH side of A/C, 1/2-in. aircraft black letters.	HAND HOLD
8	Top surface access panel anti-icing valve, and above on fuselage, 1/2-in. aircraft black letters.	3T-5 LH side 4T-6 RH side
9	Engine inlet duct (cross hatching zone). Do not block any slots or holes. Do not paint anodized areas. Paint aircraft black.	
10	Engine cowl hinged (engine) 1/2-in. aircraft black letters.	3T-7 LH side 4T-8 RH side
11	LH top surface of oil cooler access panel, 1/2-in. olive drab No. 34087, letters, MIL-C-46168.	3T-25

Figure 9-42. Exterior and Interior Markings, UH-60 (Sheet 5 of 20)



CODE NO.	DIRECTIONS	WORDING
12	LH and RH module station 412, 2 places, 1/2-in. aircraft black letters.	HAND HOLD
13	Below LH engine exhaust and APU exhaust, 1-in. MIL-C-46168, olive drab, No. 34087, letters. NOTE: Below LH engine exhaust use 1-in. MIL-C-46168, aircraft black letters, No. 37038, letters on HIRSS equipped aircraft.	DANGER EXHAUST
14	Both sides of transition fuselage FS 435, WL 246, aircraft black. (See paragraph 7-28 for dimensions.)	
15	LH access panel drive shaft, 1/2-in. aircraft black letters.	5T-6T-9
16	LH access panel drive shaft, 1/2-in. aircraft black letters.	5T-6T-10
17	Dot at FS 585, WL 227, approximately, MIL-C-46168 aircraft red, No. 31136.	● .75 DIA
18	Dot at FS 625, WL 227, approximately, blue, No. 35044.	● .75 DIA
19	Pylon D.S. covers NHF-FM No. 1 antenna, 1/2-in. MIL-C-46168, olive drab, No. 34087, letters.	5T-6T-11
20	Left side of pylon near pylon steps, 3 places, 1/2-in. aircraft black letters.	PUSH AND TURN TO RELEASE 
21	Near gear box fairing and light support, 1/2-in. aircraft black letters.	5T-6T-12
22	Stencil for troop commander antenna 1/2-in. olive drab letters.	5T-6T-13
23	Access panel above upper actuator attach. 1/2-in. aircraft black letters.	5T-14
24	Pylon trailing edge, 1/2-in. aircraft black letters.	5T-6T-15

Figure 9-42. Exterior and Interior Markings, UH-60 (Sheet 6 of 20)

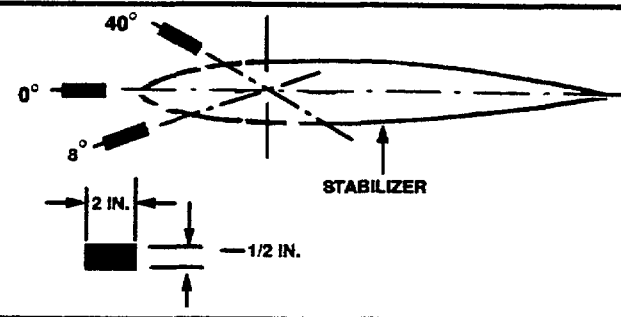


CODE NO.	DIRECTIONS	WORDING
25	Aft pylon call out for stabilizer degrees, 1/2 in aircraft black letters.	
26	Lower pylon, 1/2-in. aircraft black letters.	5B-6B-16
27	Lower aft section of tail rotor pylon, FS 680, WL 218 approximately. The word CAUTION to be 1-in. aircraft black letters, remainder 1/2-in. aircraft black letters.	CAUTION GROUND STRAP INSIDE DETACH DURING REMOVAL
28	Gear box access cover, 1/2-in. aircraft black letters.	5T-6T-17
29	Near pylon fold, 1/2-in. aircraft black letters.	WARNING DISCONNECT ELECTRICAL HYDRAULICS AND CONTROLS BEFORE FOLDING
30	Tail cone just fwd of access panel, FS 640, WL 224, 1/2-in. aircraft black letters.	STRUCTURAL ACCESS PANEL MUST BE FITTED BEFORE FLIGHT
31	Structural access panel and above on fuselage, 1/2-in. aircraft black letters.	5T-5B-18
32	Tail cone lower fuselage, FS 640, 1/2-in. aircraft black letters.	TIRE PRESSURE 115-125 PSI
33	Tail cone lower aft section, FS 635, 1/2-in. aircraft black letters.	UTILITY MAINT. LIGHT RCPT. BLO 
34	Tail cone fuselage above and aft of the tie down ring, 1/2-in. aircraft black letters. 2 places.	JACKING POINT 
35	Top of antenna, 1-in. olive drab letters.	NO STEP
36	Top side of VOR/LOC antenna, 1/2-in. olive drab letters.	5B-5T-19

Figure 9-42. Exterior and Interior Markings, UH-60 (Sheet 7 of 20)

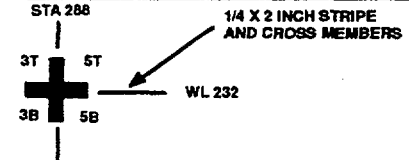


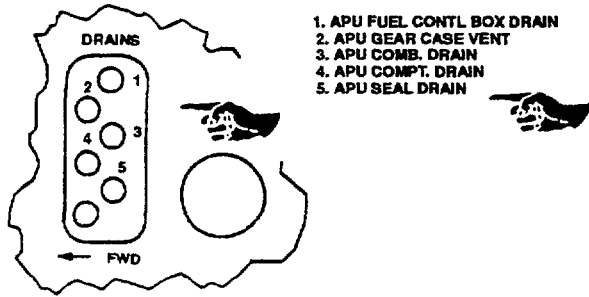

CODE NO.	DIRECTIONS	WORDING
37	Tail cone fwd section stencil between FS 501 and FS 503, 1/2-in. aircraft black letters.	PROVISION FOR CHAFF DISPENSER
38	LH side of A/C, FS 488, WL 232, aircraft black.	
39	Locate stencil at FS-485 above tie down ring, 1/2-in. aircraft black letters.	
40	Transition fuselage cover, FS 467, WL 229, 1/2-in. aircraft black letters.	ACCESS COVER MAG FLUX VALVE
41	Access cover and above on fuselage, 1/2-in. aircraft black letters.	3B-3T-20
42	Transition fuselage above access cover, FS 446, WL 223, 1/2-in. aircraft black letters.	
43	Access cover, 1/2-in. aircraft black letters.	3T-3B-21
44	Transition fuselage section adjacent to fuel vent drain, 1/2-in. aircraft black letters.	
45	Access cover pressure/closed circuit refueling cap, 1/2-in. aircraft black letters.	
46	Below code 45, 1/2-in. aircraft black letters.	3T-3B-23

Figure 9-42. Exterior and Interior Markings, UH-60 (Sheet 8 of 20)


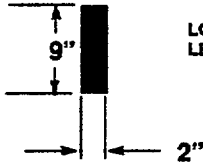
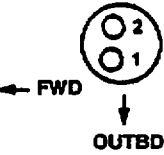
CODE NO.	DIRECTIONS	WORDING
47	Bottom side of access door, FS 421, BL 5, 1/2-in. aircraft black letters.	FUEL SUMP DRAIN
48	Transition fuselage aft of top fuselage step, 1/2-in. aircraft black letters.	 <p>FUEL FILLER CAP FUEL FILLER CAP 181 GALS J P 4 FUEL</p>
49	Apply non-skid coating to all walkways, step and platforms. Paint aircraft black.	
50	Stencil all step areas as shown, aircraft black stripe.	 <p>LOCATE ON RIGHTHAND AND LEFTHAND SIDE OF AIRCRAFT</p>
51	Adjacent to drain at FS 390, WL 204, LH and RH side of aircraft. 1/2-in. aircraft black letters.	 <ol style="list-style-type: none"> 1. ENG SUMP DRAIN ENG SWIRL/FRAME DRAIN ENG COMPT DRAIN ENG COMMON DRAIN ENG SEQ VALVE DRAIN 2. ENG COMB CHAMBER
52	Bottom side of cargo hook access cover, 1/2-in. aircraft black letters.	4B-24
53	LH interior cargo door just below emergency handle, orange-yellow arrow and 1/2-in. letters.	<p>EMERGENCY EXIT PULL ← AFT</p>
54	Exterior LH cargo door, near horizontally oriented handle (old) or vertically oriented handle (new), 1/2-in. aircraft black letters.	<p>LOCKED CLOSED → OPEN</p> <p>OR</p> <p>↑ OPEN CLOSED & LOCKED</p>

Figure 9-42.Exterior and Interior Markings, UH-60 (Sheet 9 of 20)

CODE NO.	DIRECTIONS	WORDING
55	Interior LH cargo door, near horizontally oriented handle (new) or vertically oriented handle (old), 1/2-in. aircraft black letters.	<p>OPEN — / CLOSED</p> <p>LOCKED</p> <p>OPEN =</p> <p>CLOSED</p>
56	Paint LH interior cargo door handle aircraft black	
57	Near LH cargo door handle (old), both interior and exterior of door, 1/2-in. aircraft black letters.	HANDLE MUST BE IN 'CLOSED' POSITION BEFORE CLOSING DOOR
58	Stencil 1/8-in. wide aircraft black stripes and 3/4-in. wide orange-yellow stripes in LH cargo door window emergency jettison handle recess.	<p>3/4 INCH WIDE</p> <p>1/8 INCH WIDE</p>
59	Cabin, FS 290, WL 206, 1/2-in. aircraft black letters.	TIRE PRESSURE 130/140 PSI
60	Gunner's window sill, FS 290, 1/2-in. aircraft black letters.	STEP
61	LH and RH bottom side of aircraft at STA 260 and BL 28, 1-in. aircraft black letters.	PITOT STATIC DRAIN
62	Near lower corner of copilot door aft, 1/2-in. aircraft black letters.	EXT. I.C.S.
63	Fuselage near jack point FS 247, WL 203, 1/2-in. aircraft black letters.	<p>JACKING POINT UNDER</p>
64	LH side of A/C, 247, WL 232, aircraft black.	<p>STA 247</p> <p>1/4 X 2 INCH STRIPE AND CROSS MEMBERS</p> <p>1T 3T</p> <p>1B 3B</p> <p>WL 232</p>

Figure 9-42. Exterior and Interior Markings, UH-60 (Sheet 10 of 20)


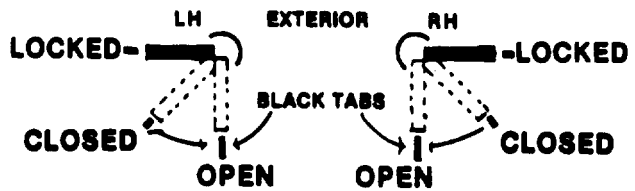
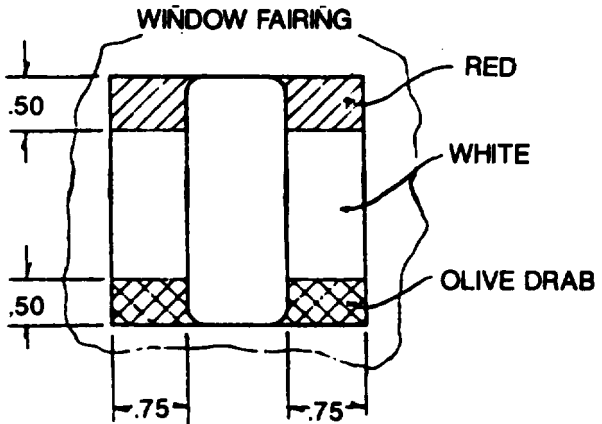
CODE NO.	DIRECTIONS	WORDING
65	Inside of cockpit copilot door on vinyl coated nylon pocket 1/2-in. aircraft white letters.	CHECK LIST DATA AND MAP STOWAGE
66	Interior of cockpit windowsill-aft of emergency handle, orange-yellow arrow and 1/2-in. letters.	
67	Pilot and copilot door handles exterior, 1/2-in. aircraft black letters.	
68	Fairing at access to shock strut 1/2-in. aircraft black letters. NOTE: Do not apply this stencil on aircraft provisioned for ESSS.	3B-30
69	Oleo inspection window paint as shown. Paint red No. 31126 White No. 37875 Olive drab No. 34087	

Figure 9-42. Exterior and Interior Markings, UH-60 (Sheet 11 of 20)

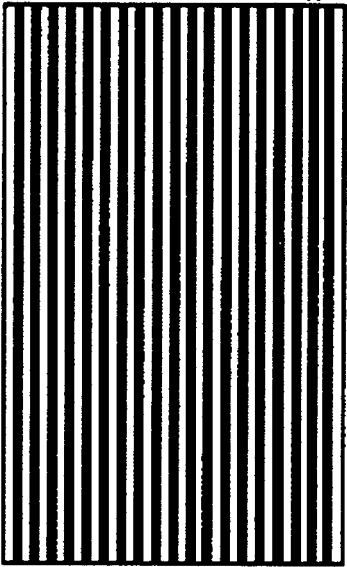

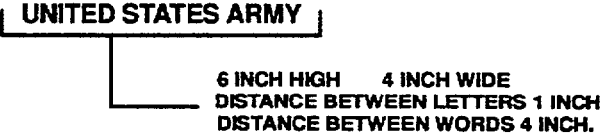
CODE NO.	DIRECTIONS	WORDING
70	Paint interior of cabin floor from FS 247 to FS 398 aircraft interior gray. Apply 2 inch wide non-skid stripes, 2 inches apart from FS 247 to FS 398. Do not apply non-skid material in floor attachment holes and counter-sinks.	<p>2 INCH SPACE GOING FWD AND AFT OF FLOOR</p> <p>2 INCH NON-SKID GOING FWD AND AFT OF FLOOR</p> <p>STA 247</p>  <p>STA 398</p> <p>INTERIOR CABIN FLOOR</p>
71	RH side of pylon steps, 3 places, 1/2-in. aircraft black letters.	<p>PUSH AND TURN TO RELEASE</p> 
72	Both sides of aircraft. On left side start U at FS 528, WL 227. On right side of aircraft finish with Y at FS 528, WL 227, aircraft black letters.	<p>UNITED STATES ARMY</p>  <p>6 INCH HIGH 4 INCH WIDE DISTANCE BETWEEN LETTERS 1 INCH DISTANCE BETWEEN WORDS 4 INCH.</p>
73	<p>Prime cross hatched area using primer MIL-P-23377. Top coat aircraft black.</p> <p>NOTE: Top coat area with aircraft green on HIRSS equipped aircraft.</p>	

Figure 9-42. Exterior and Interior Markings, UH-60 (Sheet 12 of 20)

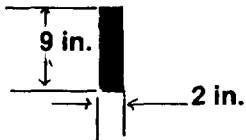
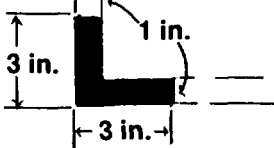

CODE NO.	DIRECTIONS	WORDING
74	DELETED.	
75	Below RH engine exhaust 1-in. olive drab letters.	DANGER EXHAUST
76	Apply non-skid coating to all walkways, steps, and platforms. Paint aircraft black.	
77	Stencil all step areas as shown aircraft black stripe.	
78	Right angle bands at LH and RH emergency exits and rescue areas, aircraft black.	
79	Engine intake duct (cross hatch area). Do not block any slots or holes. Paint aircraft black. (Do not paint any anodized areas.)	
80	Above and forward of cargo door FS 308, WL 261, 1/2-in. aircraft black letters.	
81	Apply non-skid coating to all walkways, steps, and platforms. Paint aircraft black.	
82	Gunnery window sill, 1/2-in. aircraft black letters.	STEP
83	Apply non-skid coating to all walkways, steps, and platforms. Paint aircraft Interior gray.	

Figure 9-42. Exterior and Interior Markings, UH-60 (Sheet 13 of 20)

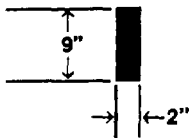

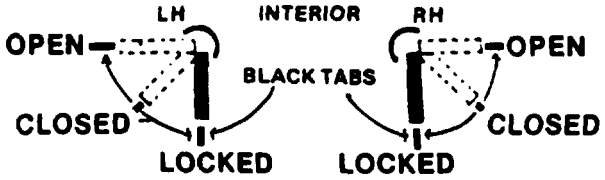
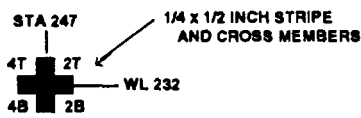
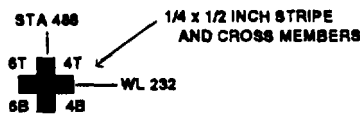


CODE NO.	DIRECTIONS	WORDING
84	Stencil at all step areas as shown aircraft black stripe	
85	Pilots cockpit on upper windshield frame interior, 1/2-in. aircraft white letters.	HAND HOLD
86	Pilots window sill aft of emergency handle, 1/2-in. orange-yellow letters.	EMERGENCY EXIT PULL 
87	Pilots and copilots door handles 1/2-in. aircraft white letters and arrows.	
88	RH side of A/C FS 247, WL 232, aircraft black.	
89	RH side of A/C FS 488, WL 232, aircraft black.	
90	Fuselage near jackpoint FS 247, WL 203, 1/2-in. aircraft black letters.	
91	Near lower corner of pilots door and aft, 1/2-in. aircraft black letters.	EXT. I. C. S.
92	Below gunners window, at FS 284, WL 216, 1/2-in, aircraft black letters	ACCESS COVER EXTERNAL POWER RECEPTACLE 115/200 VAC 400 CYCLE 
93	Fuselage above access cover, 1/2-in. aircraft black letters.	4B-26

Figure 9-42. Exterior and Interior Markings, UH 60 (Sheet 14 of 20)

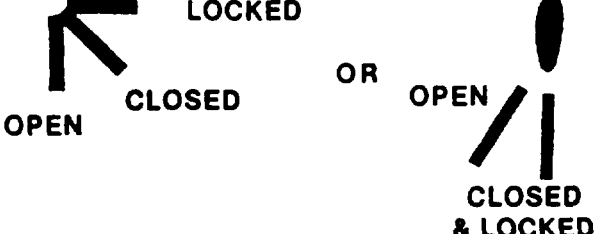
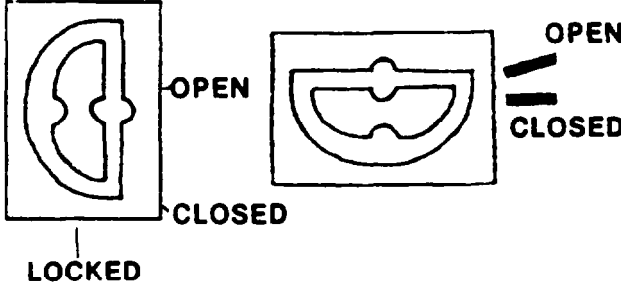
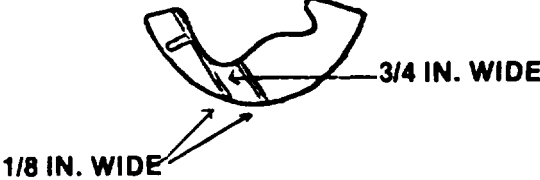
CODE NO.	DIRECTIONS	WORDING
94	Cabin, fuselage at FS 290, WL 206, 1/2-in. aircraft black letters	TIRE PRESSURE 130/140 P.S.I.
95	Fairing at access to shock strut 1/2-in. aircraft black letters NOTE: Do not apply this stencil on aircraft provisioned for ESSS. 1/2-in. aircraft black letters.	4B-31
96	Exterior RH cargo door near horizontally oriented handle (old) or vertically oriented handle (new), 1/2-in. aircraft black letters.	
97	Interior RH cargo door near horizontally oriented handle (new) or vertically oriented handle [old], 1/2-in. aircraft black letters.	
98	Paint RH interior cargo door handle aircraft black.	
99	Near RH cargo door handle (old), both interior and exterior of door, 1/2-in. aircraft black letters.	HANDLE MUST BE IN 'CLOSED' POSITION BEFORE CLOSING DOOR
100	RH interior cargo door, just below emergency handle, orange-yellow arrow and 1/2-in. letters.	EMERGENCY EXIT PULL ← FWD
101	Stencil 1/8-in. wide aircraft black stripes and 3/4-in. wide orange-yellow stripes in RH cargo door window jettison handle	

Figure 9-42. Exterior and Interior Markings, UH-60 (Sheet 15 of 20)








CODE NO.	DIRECTIONS	WORDING
102	Transition fuselage, aft of top fuselage step, 1/2-in. aircraft black letters.	 FUEL FILLER CAP 181 GAL JP 4 FUEL
103	Fuel filler access panel 1/2-in. aircraft black letters.	4T-22
104	Bottom side on access door, FS 421, BL 5, 1/2-in. aircraft black letters.	FUEL SUMP DRAIN
105	Fwd RH fuselage near external power recptl., aircraft black. (See MIL-C-834131/9-2 for dimensions.)	
106	Transition fuselage, FS 460, WL 247, 1/2-in. aircraft black letters.	FIRE EXTINGUISHER DISCHARGE INDICATOR
107	Above tie ring, FS 485, 1/2-in. aircraft black letters.	2 HOIST POINT TIE DOWN 
108	Tail cone fuselage, FS 605, 1/2-in. aircraft black letters.	PYLON STRUT MTG
109	Tail cone fuselage above and aft of tie down. 1/2-in. aircraft black letters.	 JACKING POINT 
110	Tail cone lower aft fuselage, FS 640, 1/2-in. aircraft black letters.	TIRE PRESSURE 115/125 PSI
111	Tail cone fuselage lower aft section, FS 635, 1/2-in. aircraft black letters.	 UTILITY MAINT. LIGHT RCPT. BLO 
112	Tail cone just fwd of access panel FS 640, WL 224, 1/2-in. aircraft black letters.	STRUCTURAL ACCESS PANEL MUST BE FITT'ED BEFORE FLIGHT
113	Access panel and above on fuselage, 1/2-in. aircraft black letters.	6T-6B-32

Figure 9-42. Exterior and Interior Markings, UH-60 (Sheet 16 of 20)


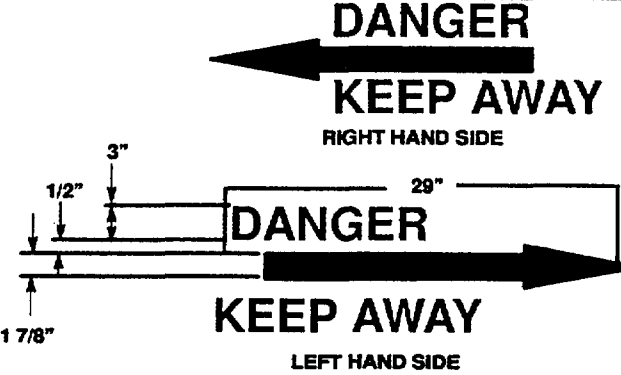
CODE NO.	DIRECTIONS	WORDING
114	Tail cone pylon fold, FS 679, 1/2-in. aircraft black letters.	PYLON FOLD STRUT MTG
115	Near pylon fold, 1/2-in. aircraft black letters.	WARNING DISCONNECT ELECTRICAL HYDRAULICS AND CONTROL BEFORE FOLDING
116	Pylon lower edge, 1/2-in. aircraft black letters.	<p>PYLON STEP UNDER PUSH UP AND TURN</p> 
117	LH and RH sides, FS 732 approximately, WL 260, aircraft black arrows and letters. Stencil radio call numbers above Danger sign in 6-in. aircraft black number.	 <p>DANGER KEEP AWAY RIGHT HAND SIDE</p> <p>DANGER KEEP AWAY LEFT HAND SIDE</p>
118	DELETE	

Figure 9-42. Exterior and Interior Markings, UH-60 (Sheet 17 of 20)

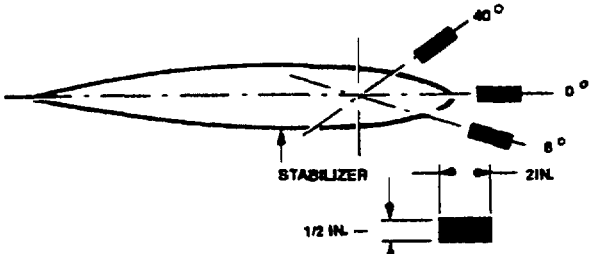
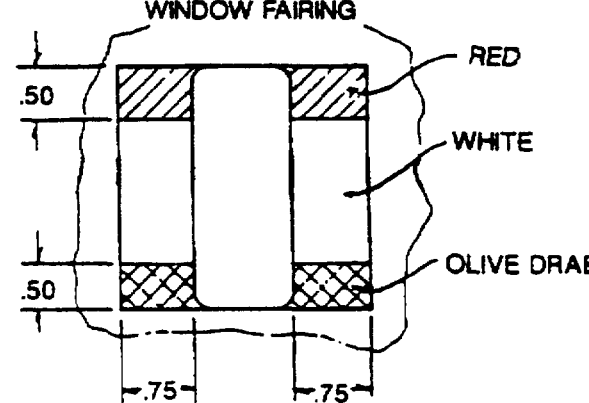
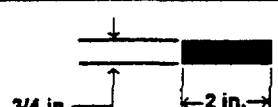
CODE NO.	DIRECTIONS	WORDING
119	Aft pylon call out for stabilizer degrees, 1/2-in. aircraft black letters, 1/2-in. wide and 2 long aircraft black stripes	
120	Oleo inspection window paint as shown red No. 31136 white No. 37875 olive drab No. 34087	
121	Locate stencil top side of cockpit between pilot and co-pilot upper window area exterior, 1/2-in. aircraft black letters.	NO STEP
122	Apply non-skid coating to all walkways, steps, and platforms. Paint aircraft black.	
123	Apply non-skid coating to all walkways, steps, and platforms. Paint aircraft black.	
124	Top side of RH APU access panel, 1/2-in. MIL-C-46168, olive drab No. 34087, letters	4T-28
125	Pylon, at FS 735, BL 0, 1/2-in. aircraft black letters.	HAND HOLD
126	Top side of stabilizer fwd spar, 1-in. aircraft black letters.	NO STEP
127	Stencil black stripe to inboard leading edge of stabilizer WL 244.40 to line up with position marks on pylon, aircraft black stripe.	

Figure 9-42. Exterior and Interior Markings, UH-60 (Sheet 18 of 20)

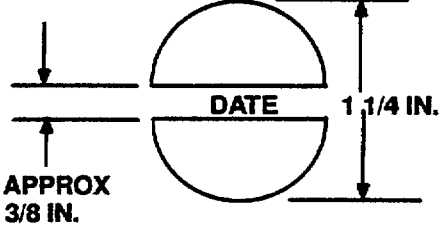
CODE NO.	DIRECTIONS	WORDING
128	LH and RH exhaust fairing top side, 1/2-in. aircraft black letters.	NO STEP
129	Top side of LH APU access panel, 1/2-in. MIL-C-46168, olive drab, No. 34087, letters.	3T-27
130	Right side of engine nacelle near screen, 1/2-in. aircraft black letters.	NO STEP
131	Paint underside of sliding fairing aircraft black #37038.	
132	Inside of cockpit pilot door on vinyl coated nylon pocket, 1/2-in. aircraft white letters.	CHECK LIST DATA AND MAP STOWAGE
133	RH underside of APU access panel, 1-in. aircraft black letters.	NO STEP
134	LH underside of APU access panel, 1-in. aircraft black letters.	NO STEP
135	Below gunners window, FS 260, WL 220 approximately, black 1/4-in. letters. **Contractor will insert their code.	**WP1-P2-L3 Date WP - indicates wash primer used P - indicates primer used L - indicates lacquer used (if req'd) C - indicates coating used (if req'd)
136	Below code 135. NOTE: Date shown on stencil is date aircraft painted with MIL-C-46168 paint.	
137	Back of Norton Armored crew seat, P/N RA30525-1. First line 1/2-in., second line 3/8-in., remaining 1/4-in. orange-yellow letters.	<p style="text-align: center;">WARNING</p> <p style="text-align: center;">SEAT TILT RELEASE</p> <p>PULL EMERGENCY RELEASE LEVER TO RIGHT, PUSH TILT HANDLES INWARD, TILT SEAT REARWARD.</p>

Figure 9-42. Exterior and Interior Markings, UH-60 (Sheet 19 of 20)

CODE NO.	DIRECTIONS	WORDING
138	Dot between holes, FS 624, WL 227 (approximately), aircraft yellow No. 33538.	● .75 dia
139	Dot between holes, FS 585, WL 227 (approximately), aircraft black.	● .75 dia
140	Both sides of aircraft on side ends of instrument glare shield, 1/2-in. aircraft white letters.	NO HAND HOLD
141	Top of both collective stick cover panels, 1/2-in. aircraft white letters.	NO STEP
142	Aircraft battery cover behind copilot's seat, 1/2-in. aircraft black letters.	BATTERY
143	LH and RH side of aircraft on ESSS fixed provision upper fairing assembly (fwd and aft sections), 1-in. aircraft black letters.	NO STEP
144	LH and RH side of aircraft on ESSS fixed provision upper fairing assembly platform, 1/2-in. aircraft black letters.	HAND HOLD
145	Access panel both RH and LH side of aircraft and above on fuselage air-oil strut, 1/2-in. aircraft black letters. NOTE: Apply only on ESSS provisioned aircraft.	3T-3B-37 4T-4B-38
146	Both RH and LH side of aircraft on fairing at access to shock strut, 1/2-in. aircraft black letters. NOTE: Apply only on ESSS provisioned aircraft.	3B-39 4B-40
147	Both RH and LH side of aircraft on ESSS fixed provisions lower fairing assembly (fwd) and another directly above on fuselage (2 stencils per side), 1/2-in. aircraft black letters.	3B-41 4B-43
148	Both RH and LH side of aircraft on ESSS fixed provisions lower fairing assembly (aft) and another directly above on fuselage (2 stencils per side), 1/2-in. aircraft black letters.	3B-42 4B-44
149	Both RH and LH side of aircraft on ESSS fixed provisions upper fairing assembly platform on inboard edge, 1/2-in. MIL-C-46168, olive drab, No. 34087, letters.	3T-33 4T-34

Figure 9-42. Exterior and Interior Markings, UH-60 (Sheet 20 of 20)

CODE NO.	DIRECTIONS	WORDING
150	Top of antenna 1 in. olive drab letters.	NO STEP
151	Top side of VOR/LOC antenna 1/2 in. olive drab letters,	6B-6T-19
152	Stencil 2 olive drab, No. 34087, continuous stripes around each main rotor blade. Each stripe is 1 in. wide and the center of the stripes will be 140.86 inches from the center of the blade cuff pin holes.	

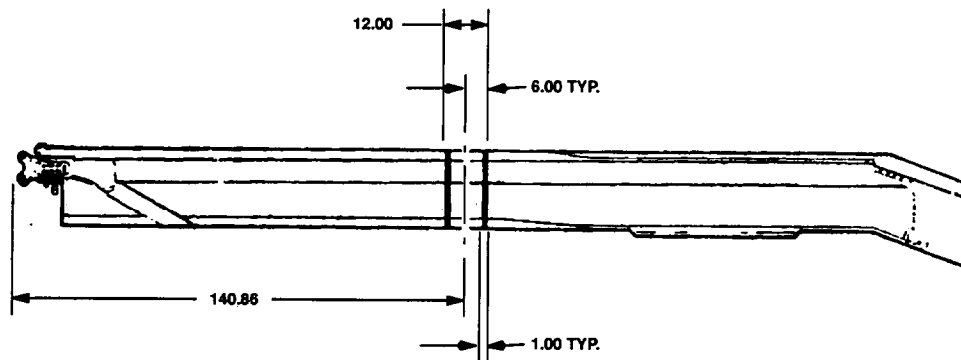


Figure 9-42, Exterior and Interior Markings, UH-60 (Sheet 20 of 20) (Con' t.)

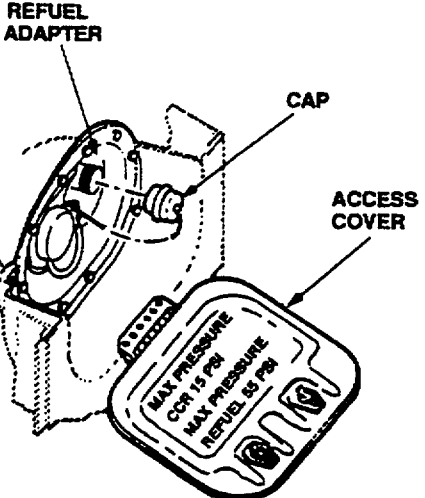
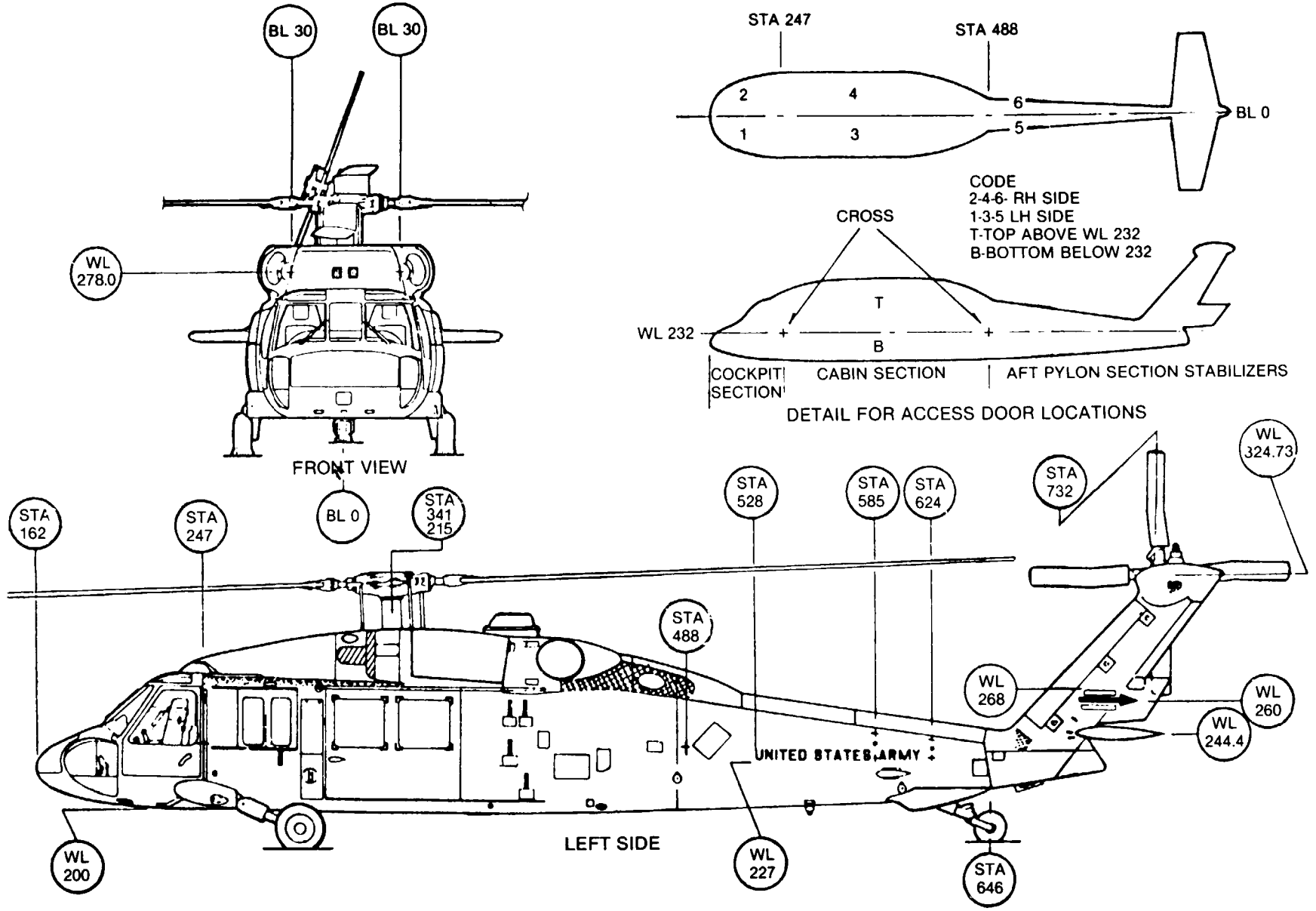
CODE NO.	DIRECTIONS	WORDING
153	Apply non skid coating on LH and RH oil cooler access panels.	
154	Apply non skid coating to LH and RH access panels.	
155	Apply 10 inch wide non skid coating to controls/accessories sliding cover.	
156	L/H slide of A/C, FS 256 WL 245, approximately, top two lines 1-inch black, #37038, Letters, remainder are 1/2-inch black, #37038 Letters	U.S. Army (insert model) U.S.A. serial No. (Insert Serial No.) Service this aircraft with MIL-T-5624 Grade JP4 Aviation fuel. If not available, refer to TB 55-0150-200-24 for alternate fuel
157	Inside pressure/closed circuit refueling access cover 1/3-in aircraft black letters.	
158	Locate stencil at FS 249, WL 219 and FS 257, LBL 29. 1/2 in. aircraft black letters	Battery Vent

Figure 9-42.Exterior and Interior Markings, UH-60 (Sheet 20 of 20) (Con't)



9-201/(9-202 blank)

Figure 9-43. Station Locations, UH-60

TM55-1500-345-23

CHAPTER 10

FIXED WING AIRCRAFT ILLUSTRATIONS

Section I. GENERAL

a. The basic external color of the aircraft in this chapter will be aircraft gray, shade No. 36231 of Federal Standard 595, in accordance with MI L-C-46168.

b. All markings, unless otherwise specifically noted in the following figures, will be aircraft black, shade No. 37038 of Federal Standard 595, in accordance with MI L-C-46168.

c. Unless otherwise specified herein, all lettering will be standard 50%260/0 letters, 0.50 in. high.

d. The following closure areas of OV-1 and RV-1 aircraft shall be painted the shades indicated, in accordance with Federal Standard 595 and MI L-C-461 68:

(1) Landing gear, wheels, inside of landing gear doors and wheel wells - aircraft white, shade No. 37875.

(2) Areas of speed brakes and flaps which are concealed when fully closed or retracted - aircraft red, shade No. 31136.

Section II. C-12 and RC-12 ILLUSTRATIONS

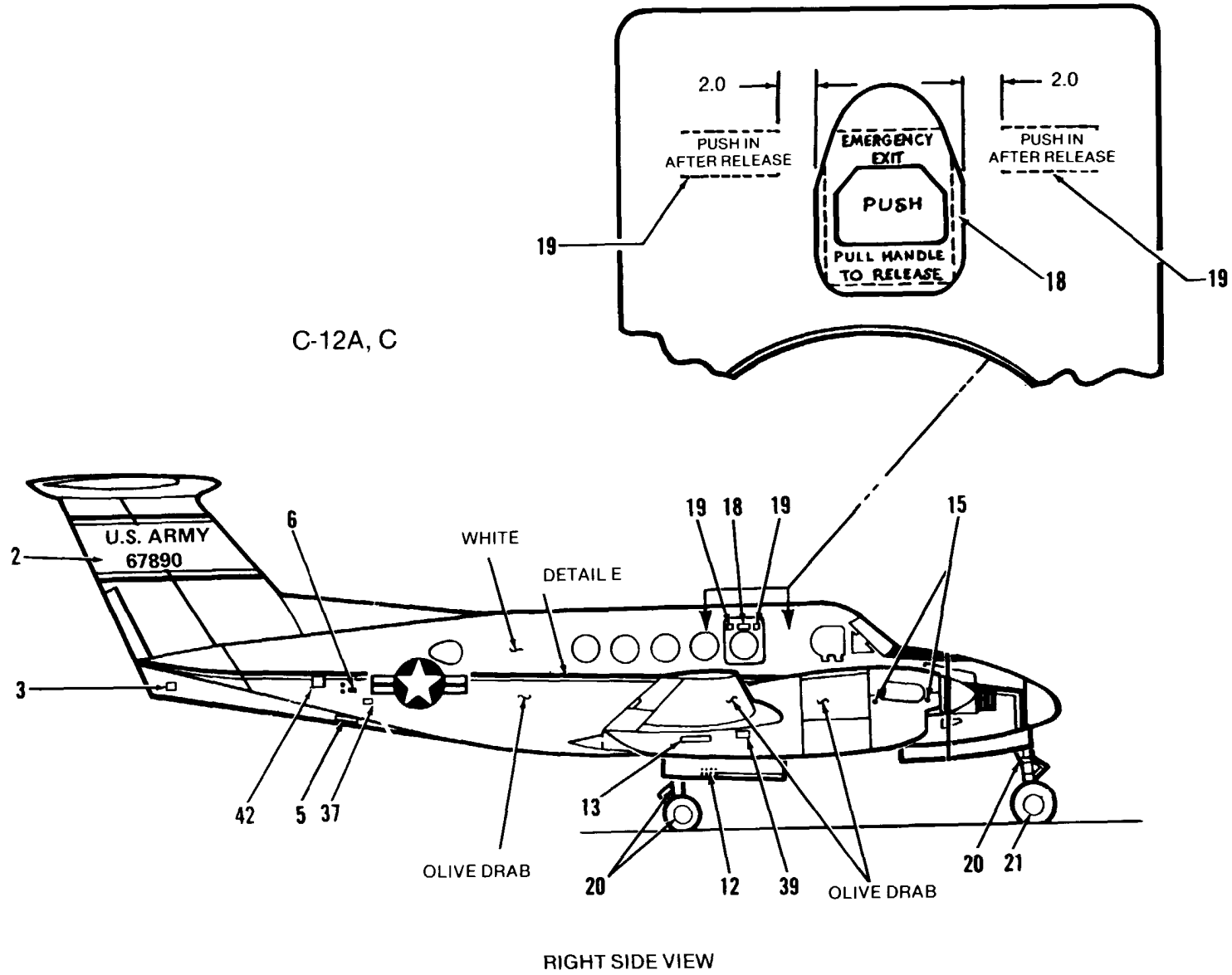


Figure 10-1. Exterior Markings, C-12 (Sheet 1 of 27)

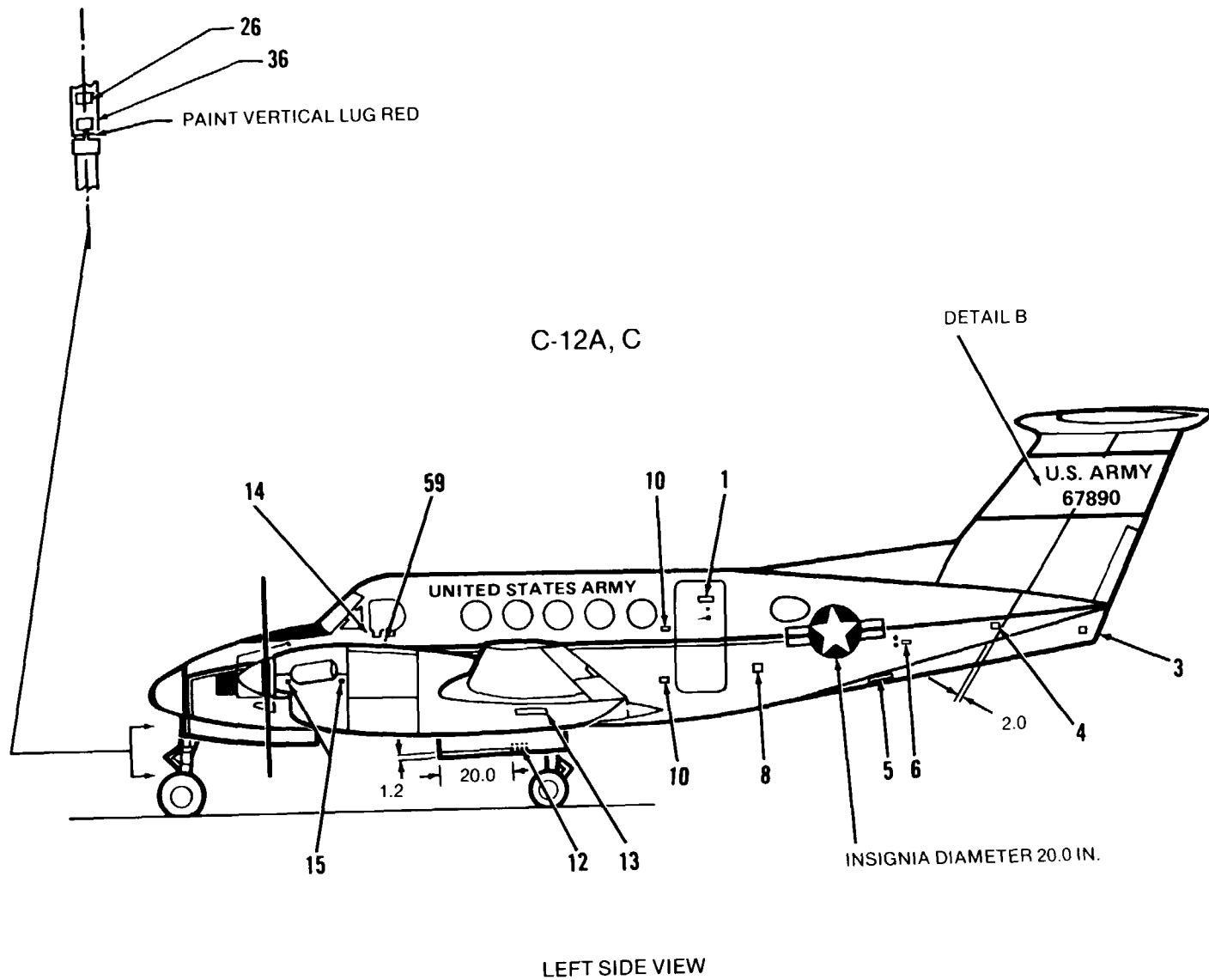
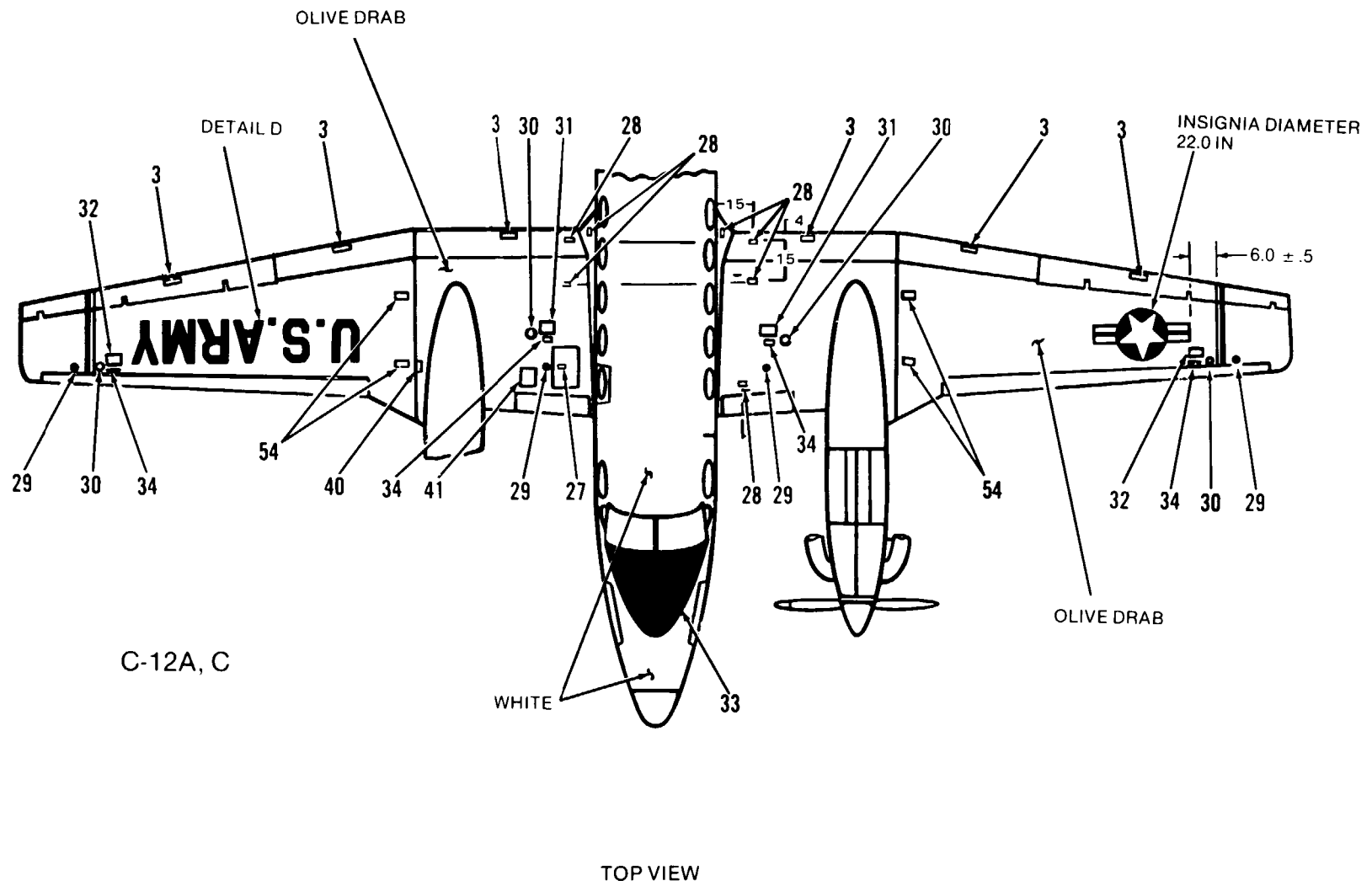


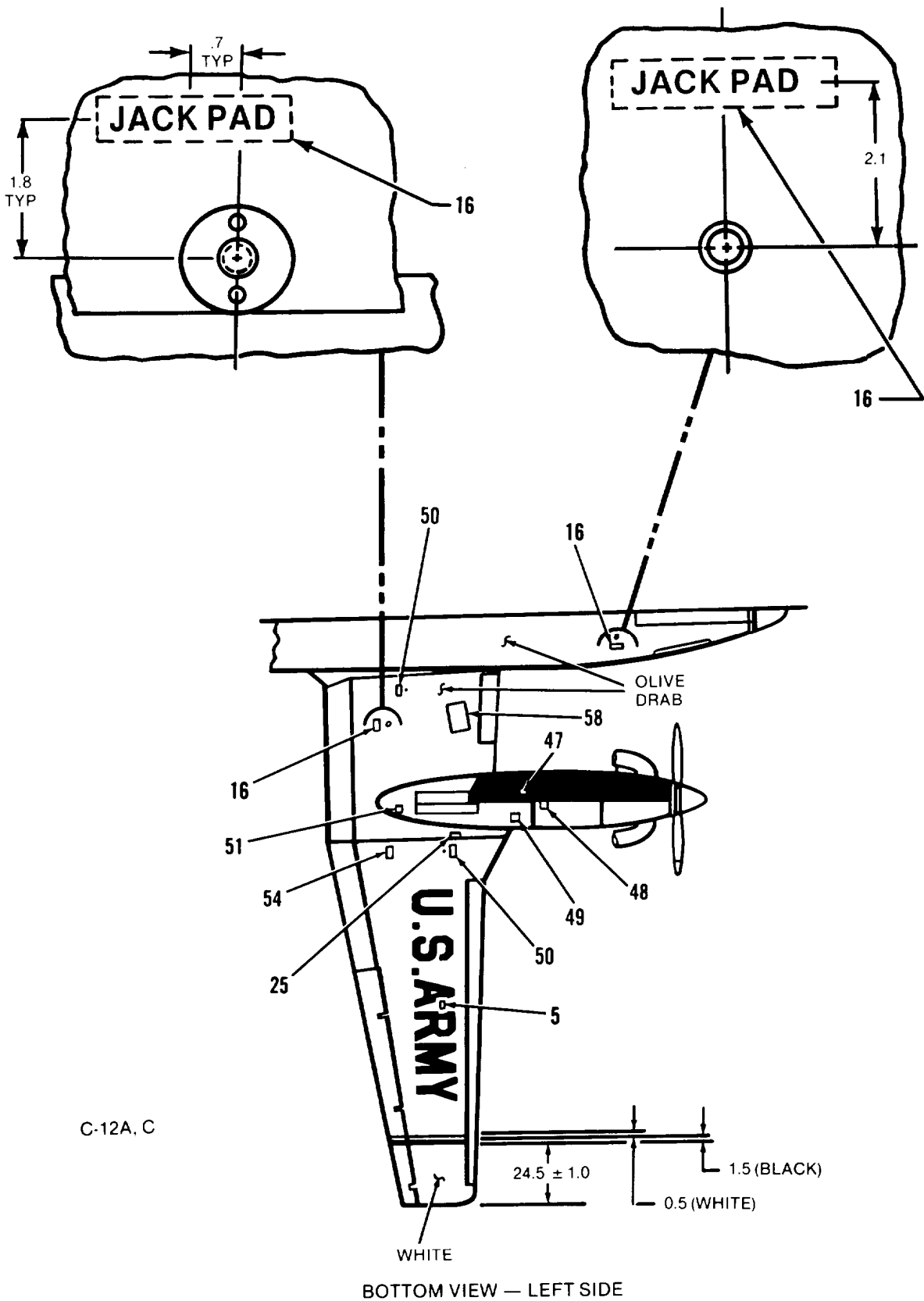
Figure 10-1. Exterior Markings, C-12 (Sheet 2 of 27)



C-12A, C

TOP VIEW

Figure 10-1. Exterior Markings, C-12 (Sheet 3 of 27)



C-12A, C

BOTTOM VIEW — LEFT SIDE

Figure 10-1. Exterior Markings, C-12 (Sheet 4 of 27)

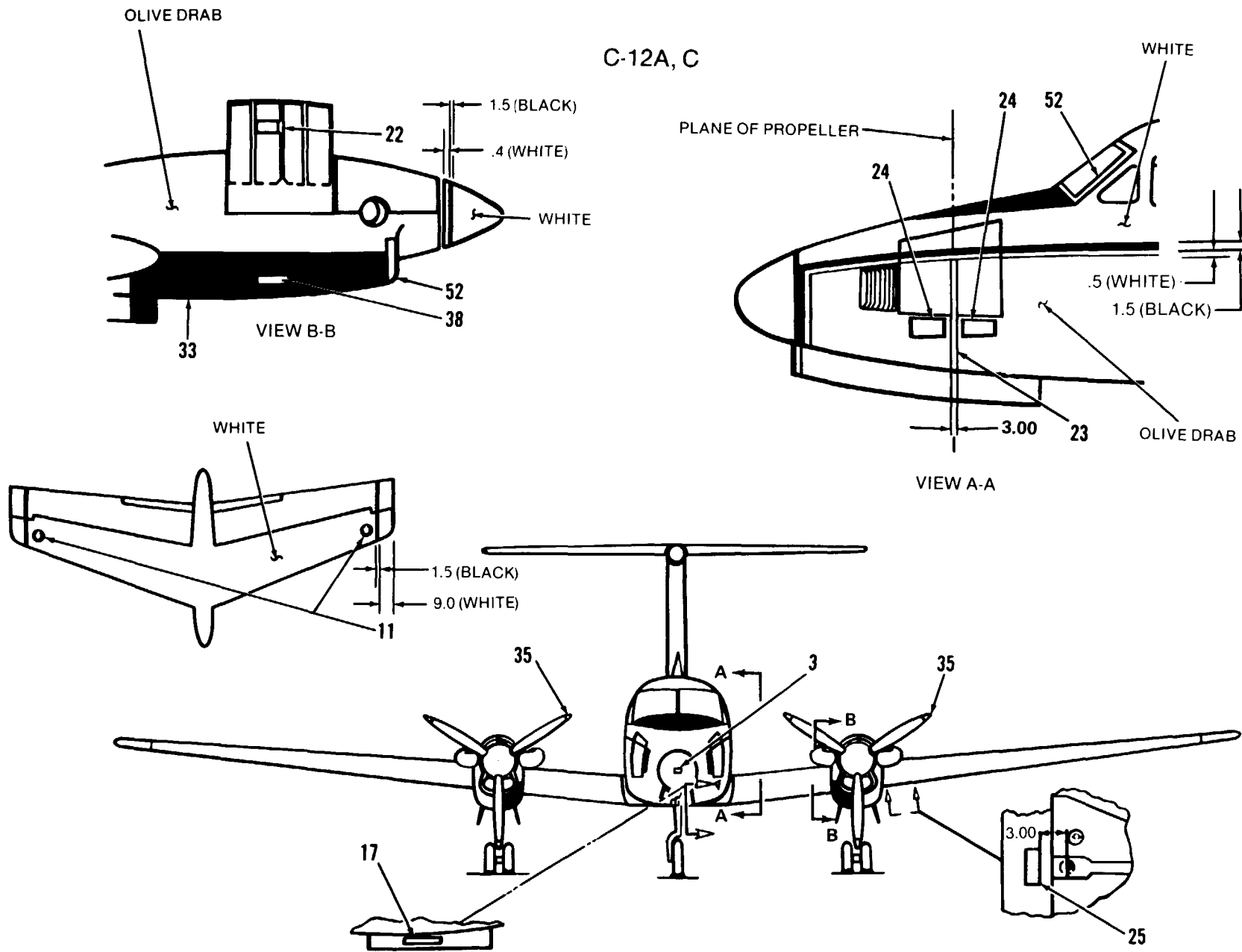


Figure 10-1. Exterior Markings, C-12 (Sheet 5 of 27)

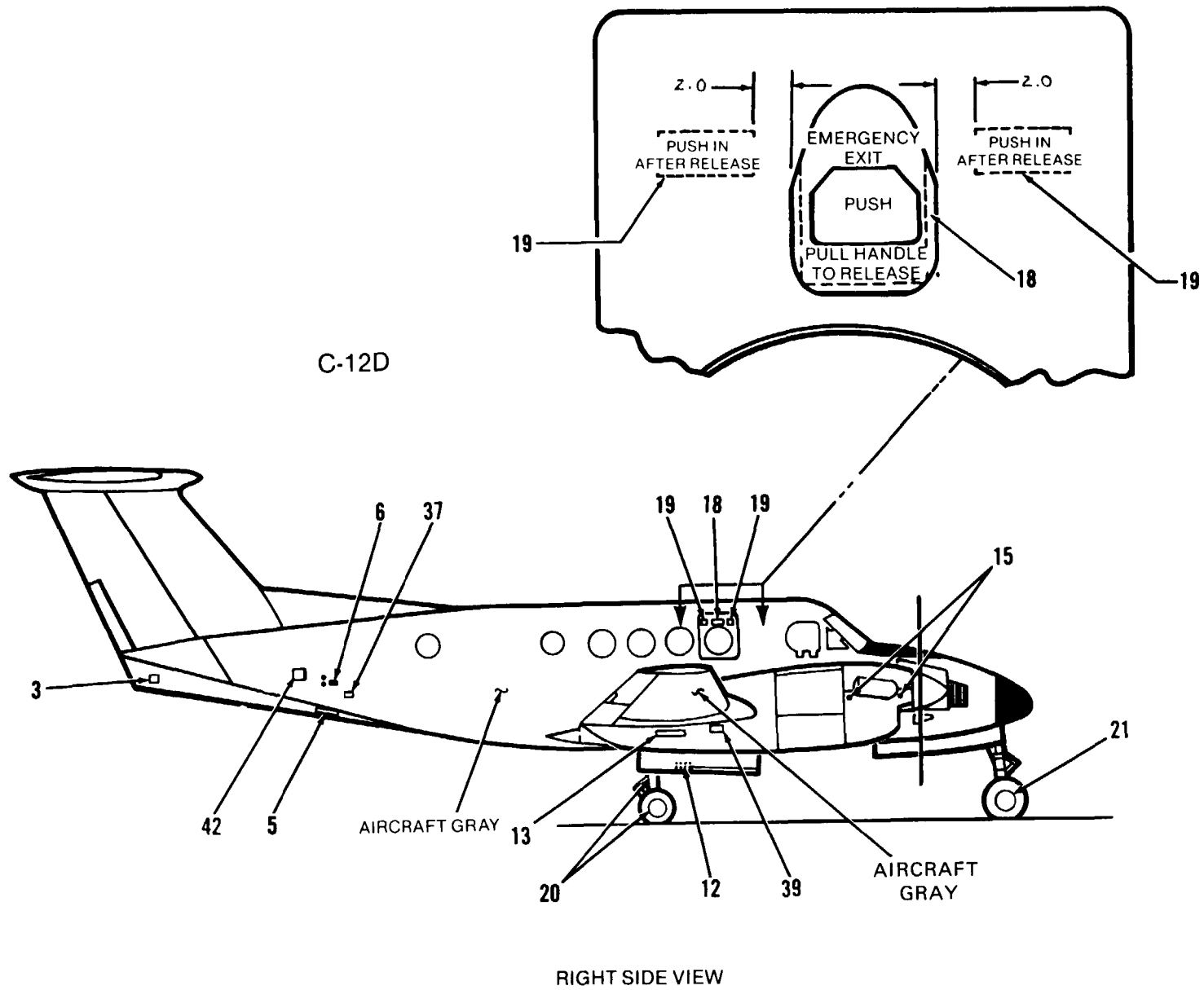


Figure 10-1. Exterior Markings, C-12 (Sheet 6 of 27)

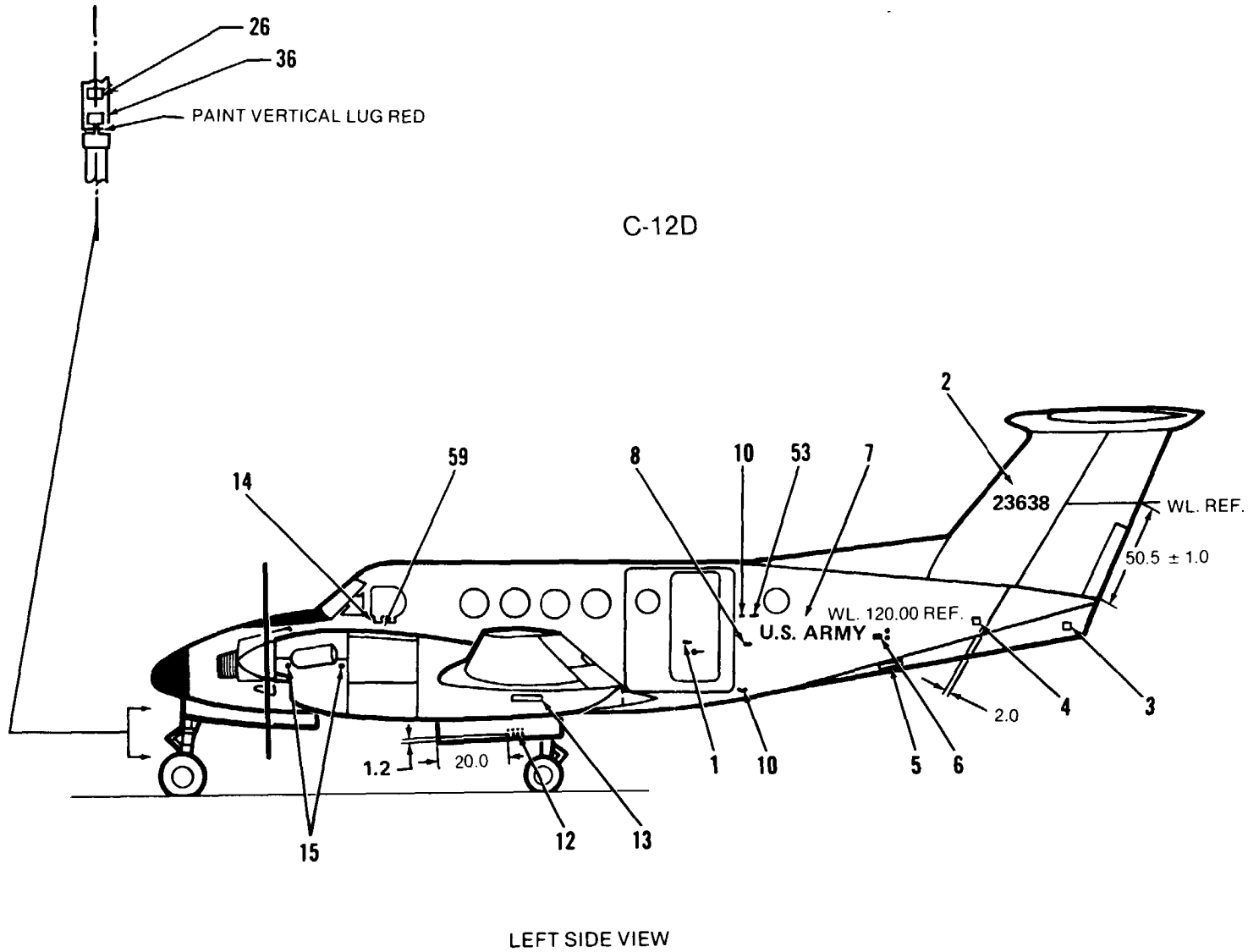


Figure 10-1. Exterior Markings, C-12 (Sheet 7 of 27)

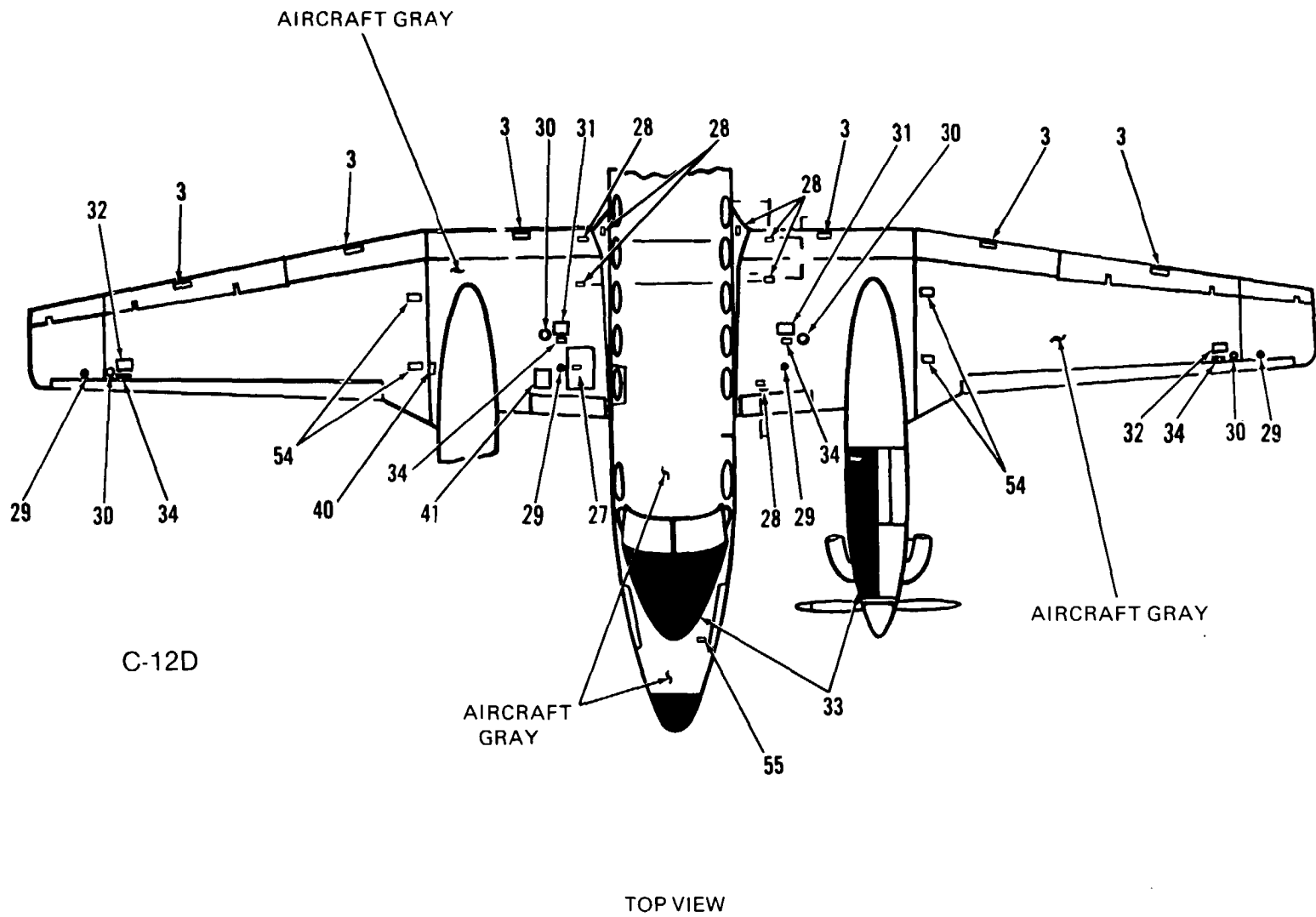
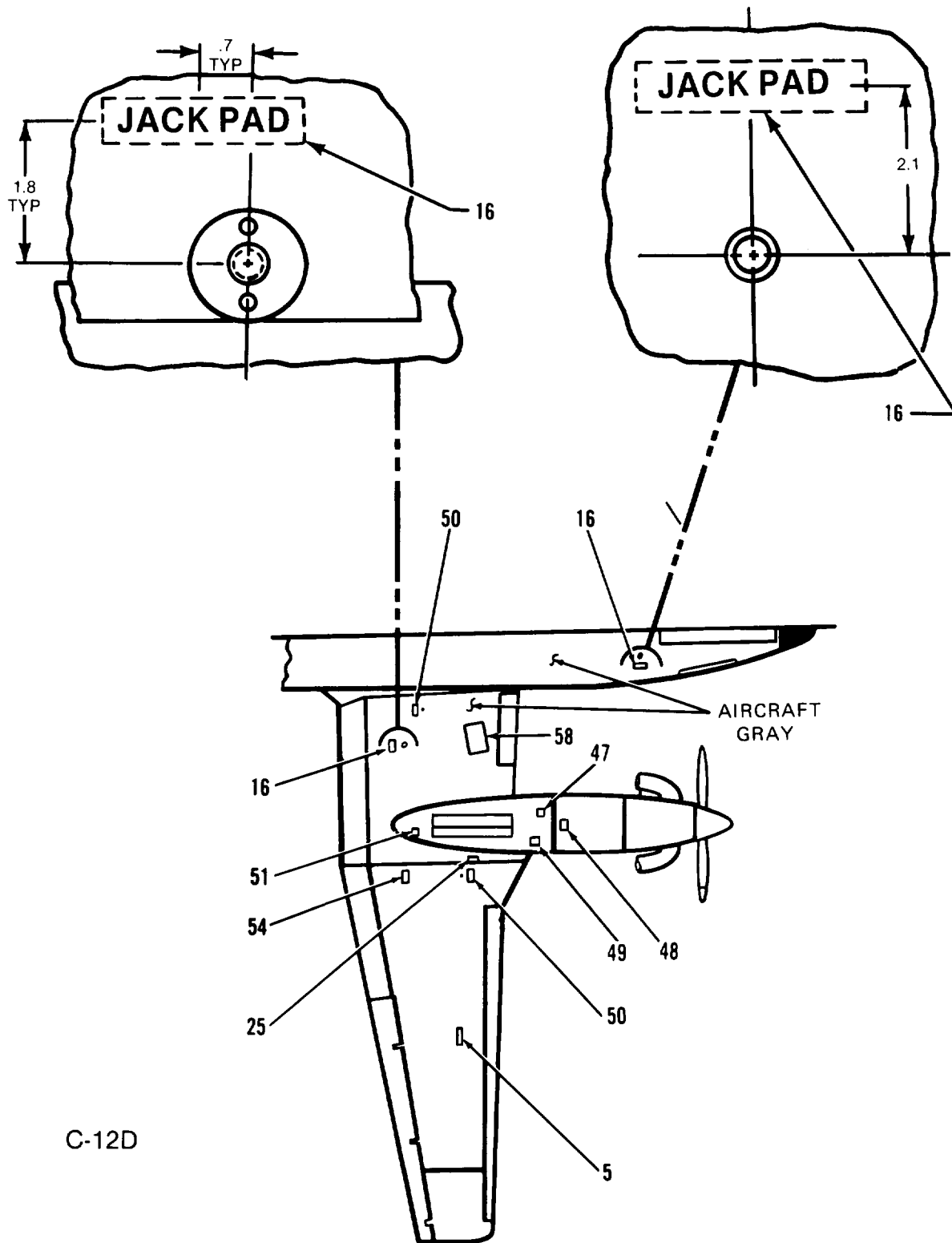


Figure 10-1. Exterior Markings, C-12 (Sheet 8 of 27)



C-12D

BOTTOM VIEW — LEFT SIDE

Figure 10-1. Exterior Markings, C-12 (Sheet 9 of 27)

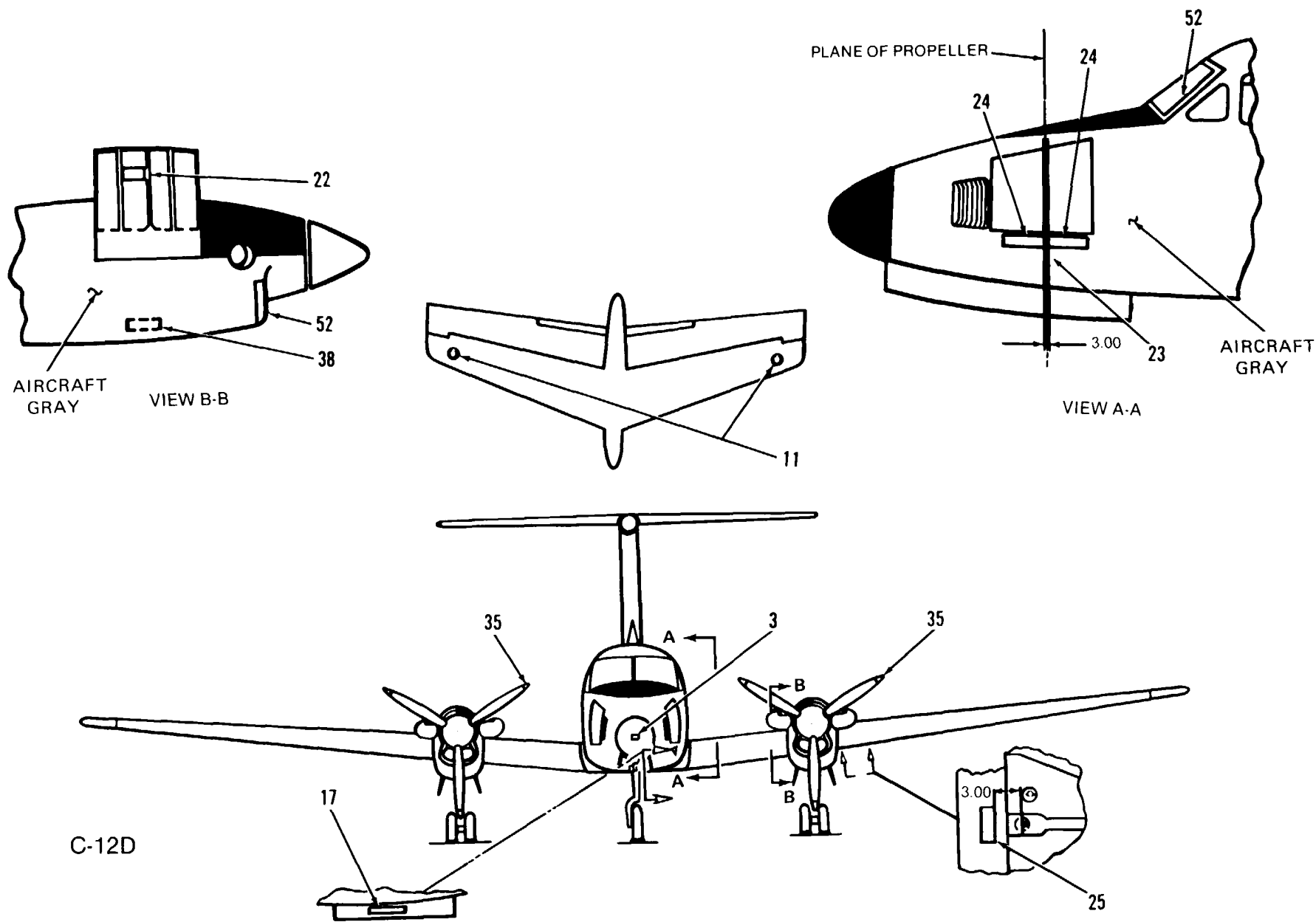


Figure 10-1. Exterior Markings, C-12 (Sheet 10 of 27)

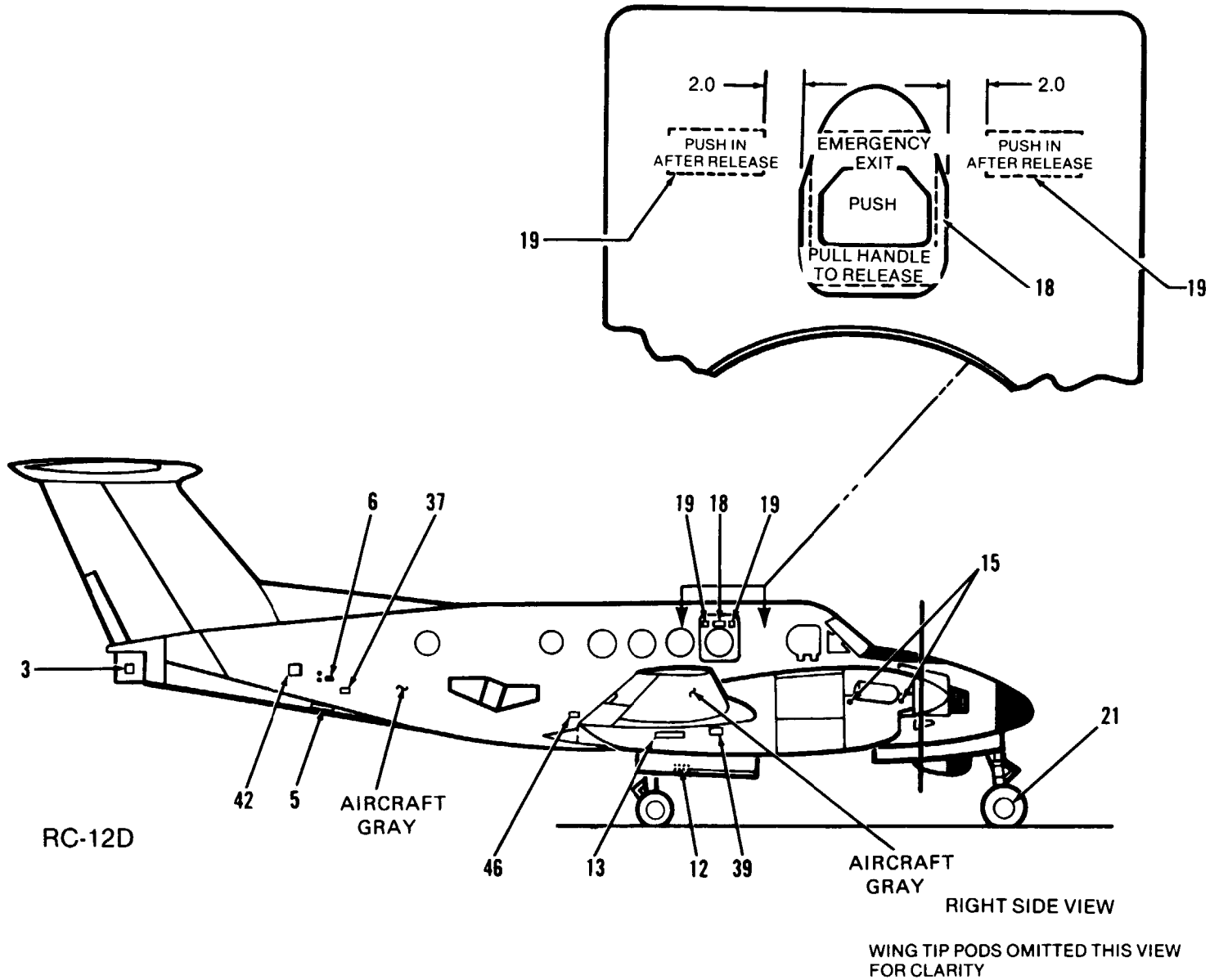


Figure 10-1. Exterior Markings, C-12 (Sheet 11 of 27)

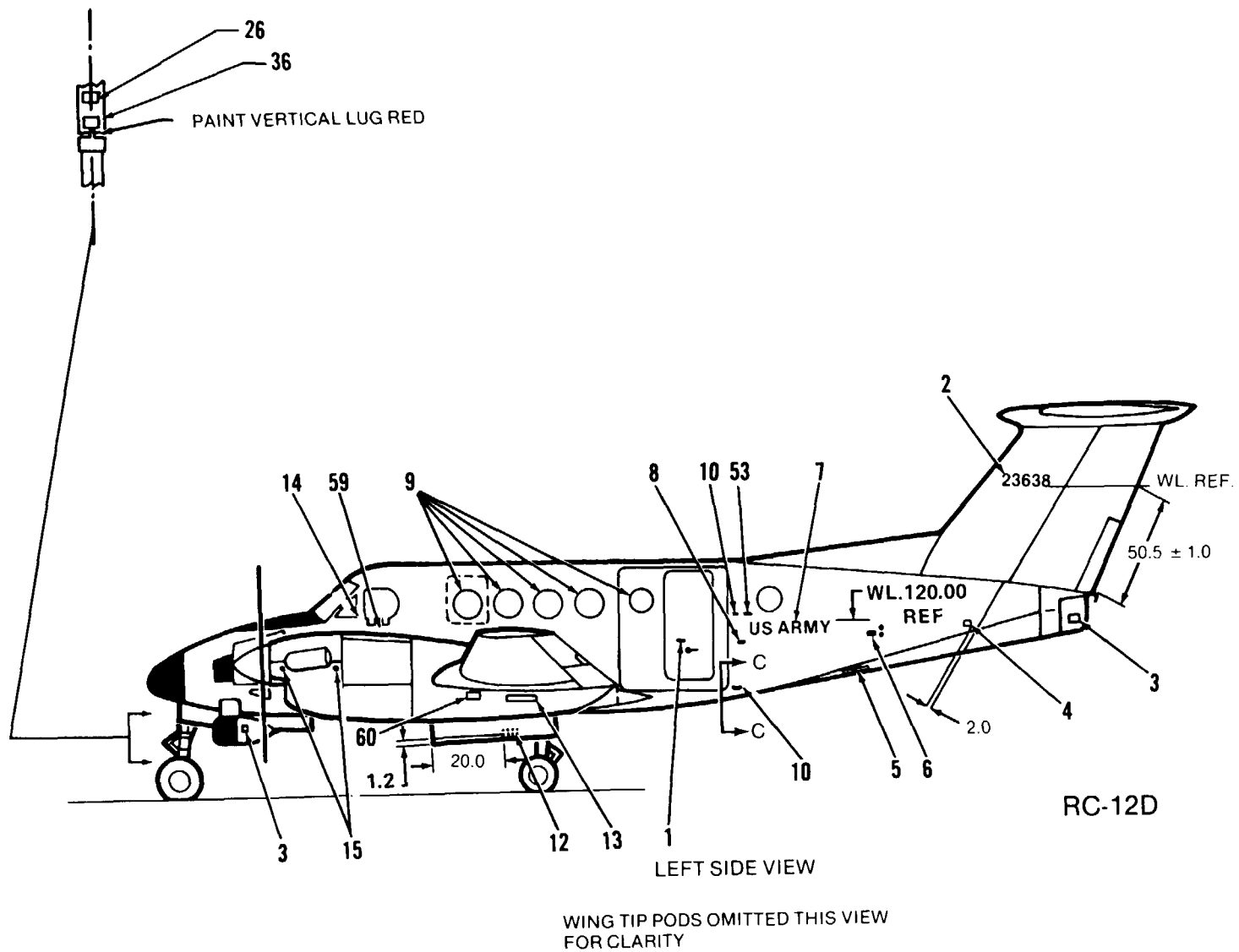
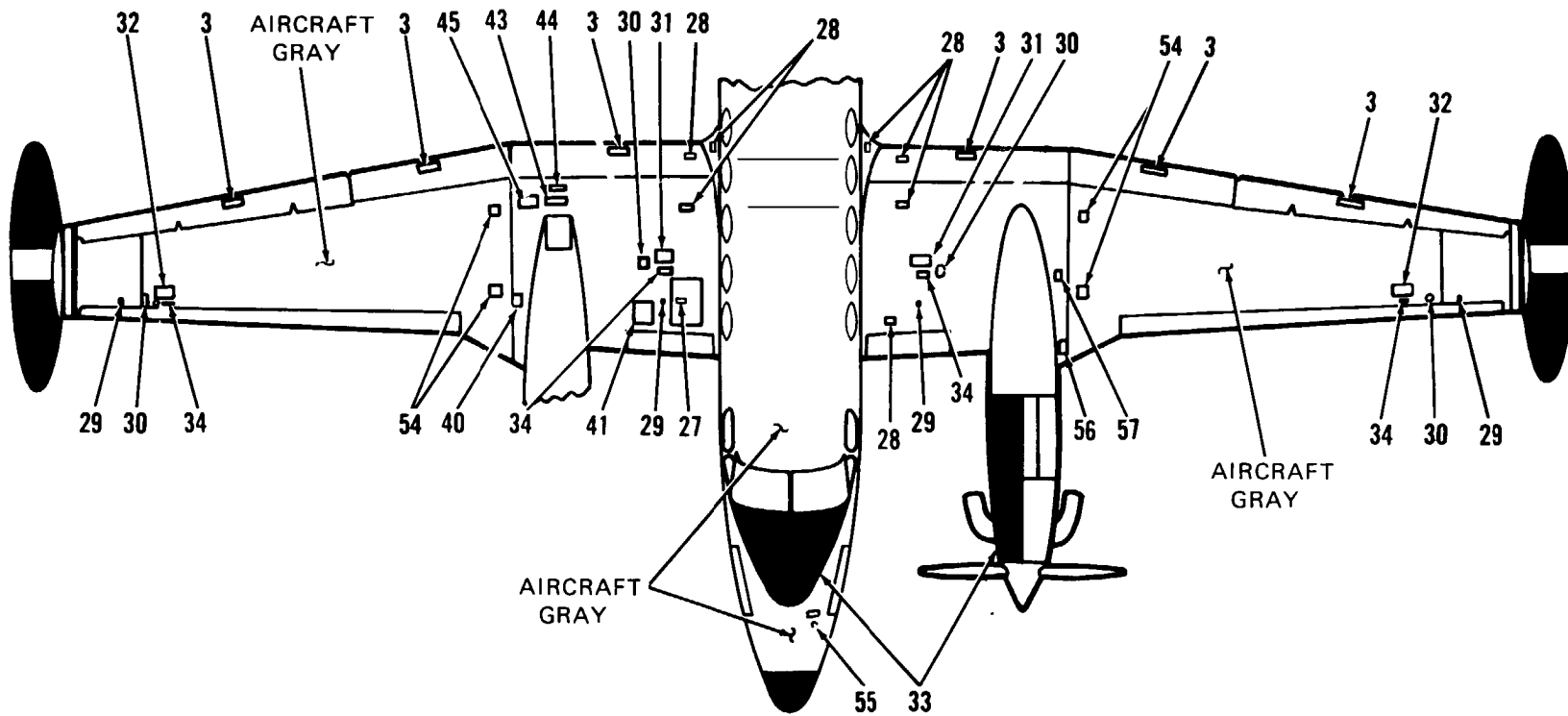


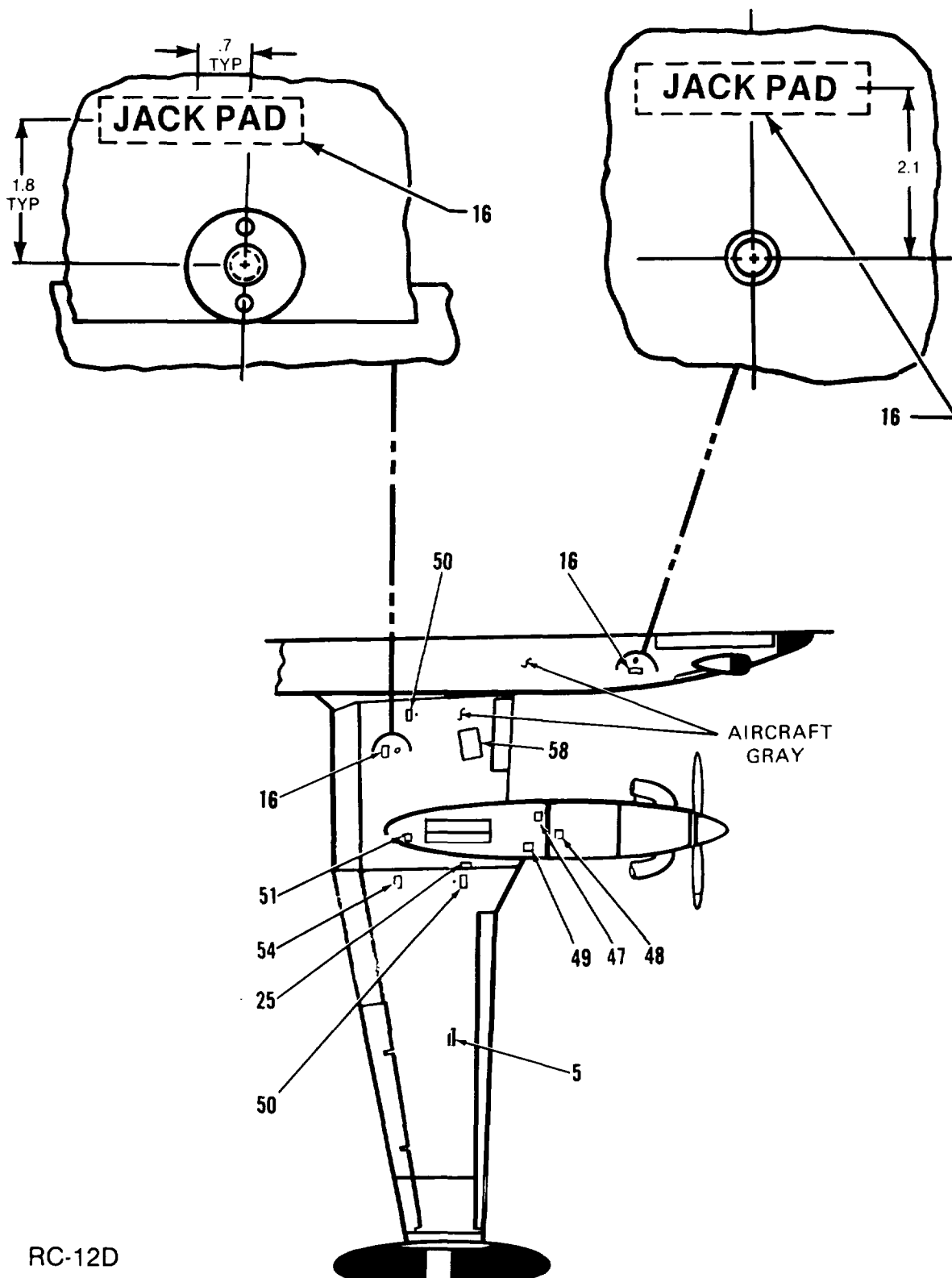
Figure 10-1. Exterior Markings, C-12 (Sheet 12 of 27)



RC-12D

TOP VIEW

Figure 10-1. Exterior Markings, C-12 (Sheet 13 of 27)



RC-12D

BOTTOM VIEW — LEFT SIDE

Figure 10-1. Exterior Markings, C-12 (Sheet 14 of 27)

RC-12D

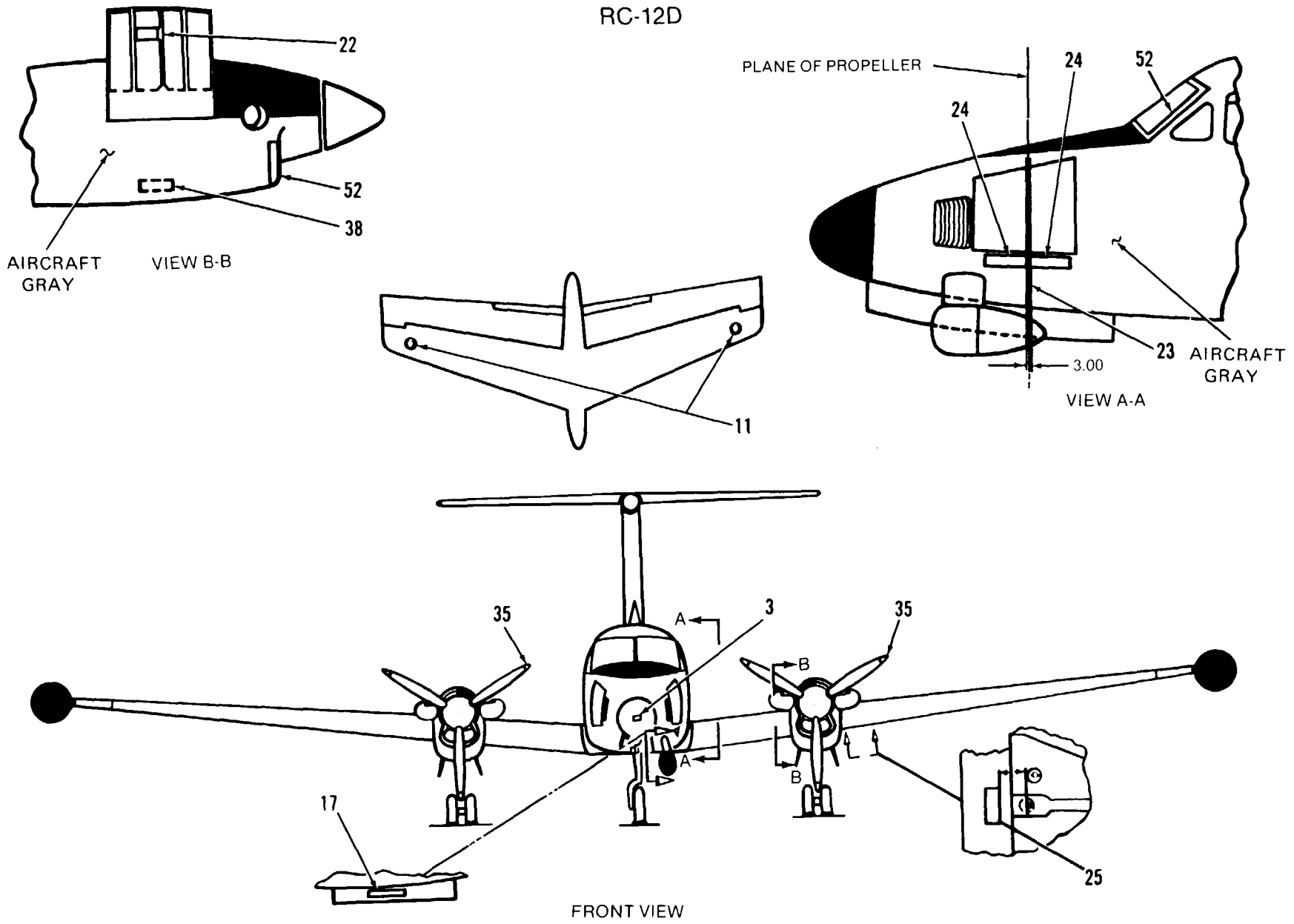
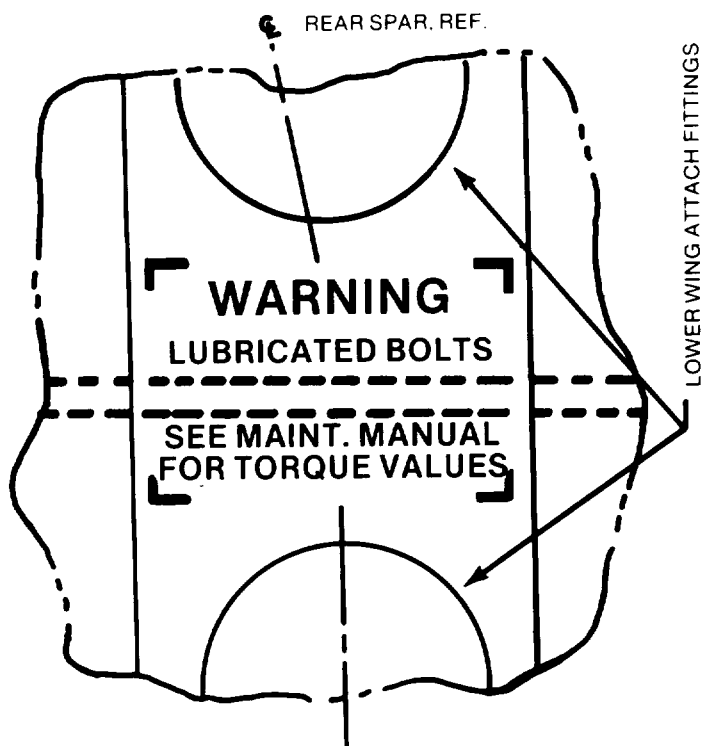
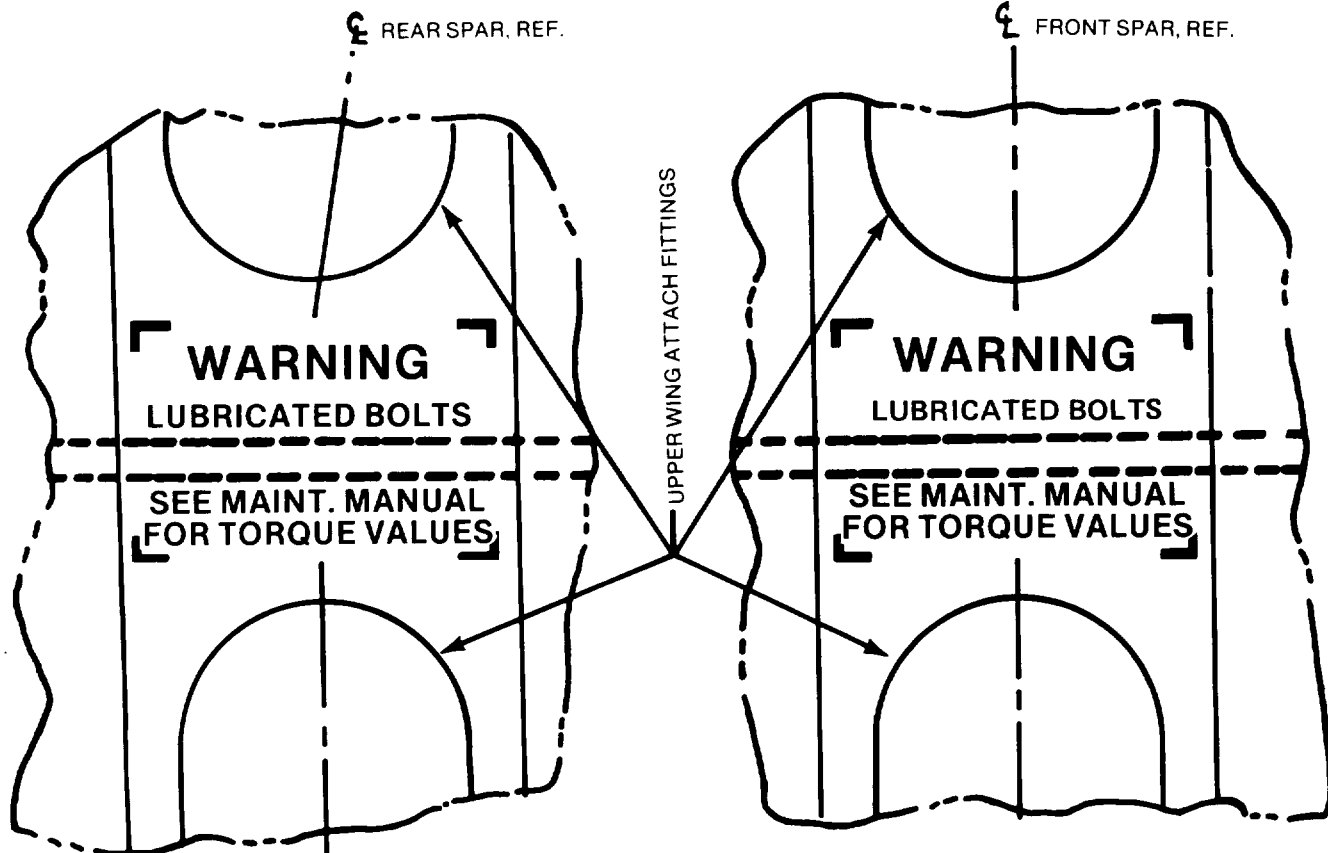


Figure 10-1. Exterior Markings, C-12 (Sheet 15 of 27)

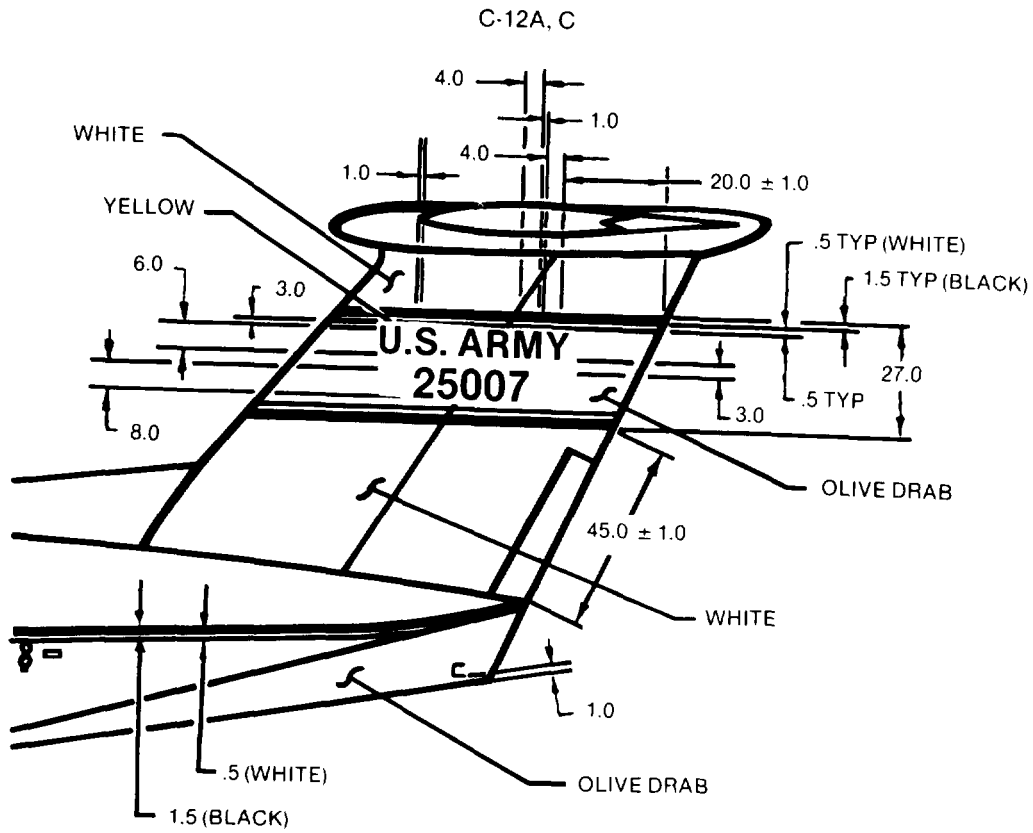


TO INSTALL DECAL ON WING ATTACH FITTINGS, CUT DECAL ON DOTTED LINES, SAND WING ATTACH FITTINGS LIGHTLY IN REQUIRED AREAS (DO NOT REMOVE PRIMER), WASH AREA WITH MEK, APPLY DECAL AND SEAL THE EDGES.

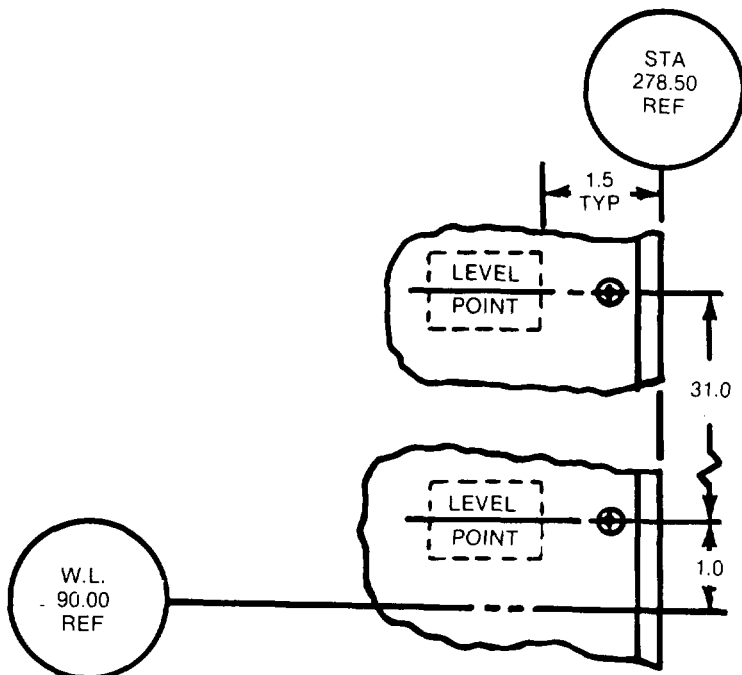


DETAIL A: WING ATTACH FITTINGS, LEFT HAND SHOWN, RIGHT HAND OPPOSITE, FITTING COVERS OMITTED.

Figure 10-1. Exterior Markings, C-12 (Sheet 16 of 27)



DETAIL B



DETAIL C

Figure 10-1. Exterior Markings, C-12

(Sheet 17 of 27)

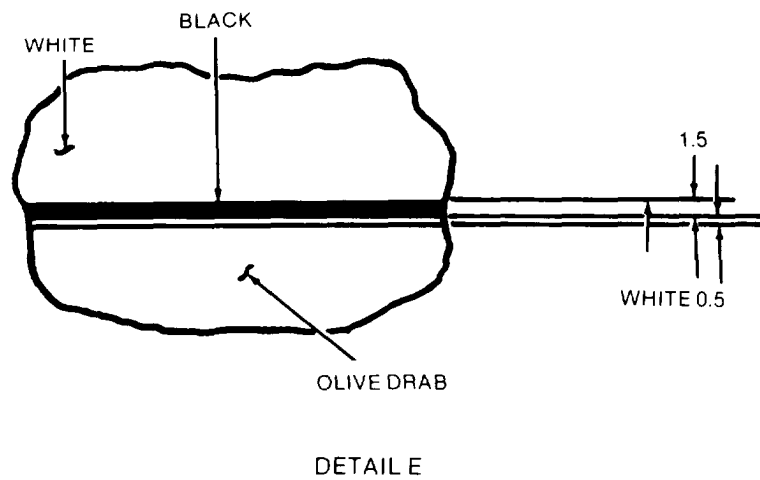
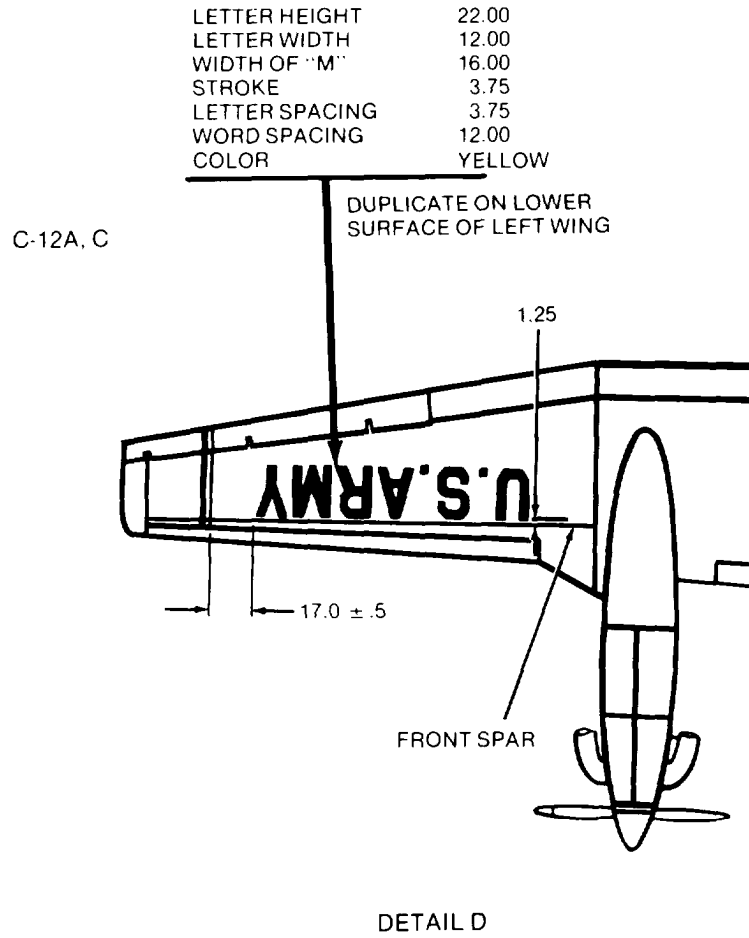


Figure 10-1. Exterior Markings, C-12 (Sheet 18 of 27)

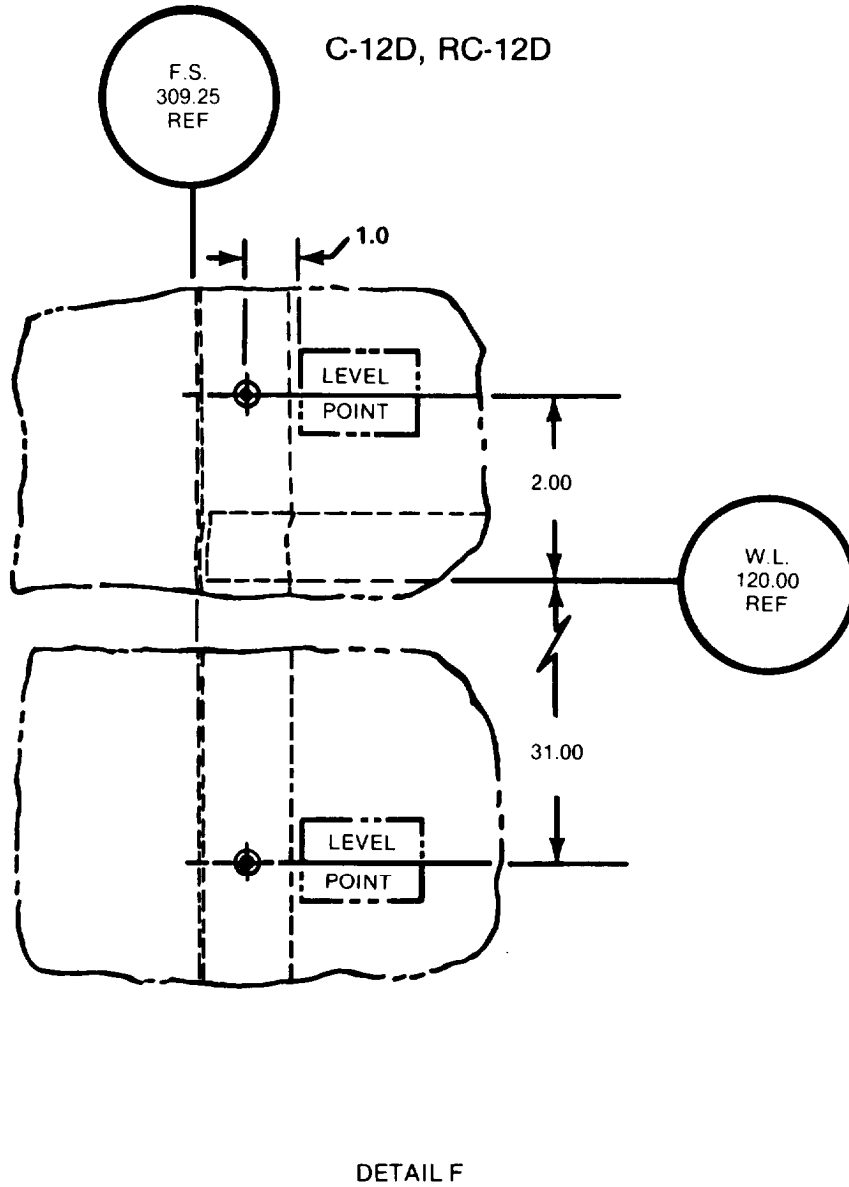


Figure 10-1. Exterior Markings, C-12 (Sheet 19 of 27)

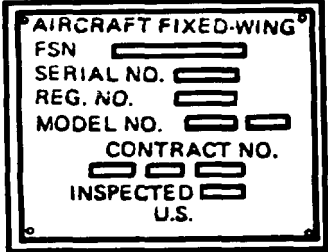
CODE NO.	DIRECTIONS	WORDING
1	Left side of fuselage on entrance air step door, adjacent to handle. 1/2-in. MIL-C-46168, aircraft black letters.	PUSH BUTTON AND TURN HANDLE TO OPEN
2	Both sides of vertical stabilizer. C-12A, C see Detail B. C-12D, RC-12D 8-in. aircraft black numbers.	(Radio call numbers)
3	C-12A and C, both sides of ventral fin, center top trailing edge of each aileron and flap, 1/2-in. yellow letters. Also center on nose cone using 1/2-in. aircraft black letters. C-12D and RC-12D, 1/2-in. aircraft black letters and MI L-C-46168 aircraft white letters on nose cone.	NO PUSH
4	Aircraft data plate located on left side of aft fuselage.	
5	C-12A and C, both sides of ventral fin and bottom center of each outboard wing panel, 1/2-in. yellow letters. C-12D and RC-12D, 1/2-in. aircraft black letters.	
6	C-12A and C, both sides of fuselage below static port. Do not paint static port. 1/2-in. yellow letters C-12D and RC-12D, 1/4-in. aircraft black letters.	STATIC AIR KEEP CLEAN
7	C-12A and C, on wings. See Detail D. C-12D and RC-12D, both sides of fuselage, aft of cabin door. Aircraft black letters.	U.S. ARMY
8	Left side of fuselage aft of cabin door, 1/2-in. aircraft black letters. ,	FIRE EXTINGUISHER INSIDE
9	Paint windows MI L-C-46168, exterior aircraft gray. RC-12D only.	

Figure 10-1. Exterior Markings, C-12 (Sheet 20 of 27)


CODE NO.	DIRECTIONS	WORDING
10	C-12A and C, left side fuselage, fwd of cabin door. Upper marking 1/2-in. aircraft black letters, lower marking 1/2-in. yellow letters. See Detail C. C-12D and RC-12D, aft of cabin door, 1/2-in. aircraft black letters. See Detail F.	LEVEL POINT
11	Left and right top of horizontal stabilizer 1/2-in. and 1/4-in. aircraft black letters.	ACCESS ASN FLUX DETECTOR CAUTION: USE NON—MAGNETIC SCREWS IN COMPASS
12	Both engine nacelles, inside each outboard main landing gear door, 1/2-in. aircraft black letters. * C-12A, C-12C; * I C-12D, RC-12D.	NORMAL PRESSURE 92-96 PSI * 73-77 PSI **
13	Aft, outboard sides of each engine nacelle, above each main landing gear door, 1/2-in. aircraft black letters.	CAUTION: DISCONNECT ELECTRICAL WIRING AND PLUMBING BEFORE REMOVING WING
14	Left side of fuselage under cockpit window. Enter appropriate model* and aircraft serial number. 1/2-in. aircraft black letters. I C-12A, C12C, C-12D, or RC-12D.	U.S. ARMY * U.S.A. SERIAL NO. 00000
15	C-12A and C, inboard and outboard fwd sides of both engine cowlings, four places on each cowling, yellow. C-12D and RC-12D, aircraft black.	
16	C-12A and C, aft of nose wheel well and left of fuselage centerline. Also two on bottom of wing stubs inboard of each engine nacelle. 1/2-in. yellow letters. C-12D and RC-12D, 1/2-in. aircraft black letters.	JACK PAD
17	Locate on inboard side of left nose gear door, 1/2-in. aircraft black letters.	NORMAL PRESSURE 55-60 PSI

Figure 10-1. Exterior Markings, C-21 (Sheet 21 of 27)


CODE NO.	DIRECTIONS	WORDING
18	C-12A and C, locate on right side of fuselage above fwd cabin window, 1/2-in. red letters. C-12D and RC-12D, 1/2-in. aircraft black letters.	<p>EMERGENCY EXIT</p> <p>PUSH</p> <p>PULL HANDLE TO RELEASE</p>
19	C-12A and C, right side of fuselage above fwd cabin window, upper marking, 1/2-in. red letters, lower marking, 1/4-in. red letters. C-12D and RC 12D, 1/2-in. aircraft black letters.	<p>PUSH IN</p> <p>AFTER RELEASE</p>
20	Paint wheels, landing gear struts and wheel wells white.	
21	Locate on outboard side of nose wheel strut, 1/2-in. aircraft black letters.	<p>J A C K</p>
22	C-12A and C, locate inside inboard cowling doors, both engines, 1/2-in. yellow letters. C-12D and RC-12D, 1/2-in. aircraft black letters.	<p>LUBE OIL MIL-L-23699</p>
23	C-12A and C, locate a 3-in. band around fuselage centered on the travel of propeller tip. Red band and 2-in. white letters. C-12D and RC-12D, aircraft black band and M IL-C-46168, aircraft gray letters.	<p>P R O P E L L E R</p>
24	C-1 2A and C, both sides of fwd fuselage, fwd and aft of Code 23, Yellow letters and arrows. C-12D and RC-12D, aircraft black letters and arrows.	<p>D A N G E R</p> <p></p>

Figure 10-1. Exterior Markings, C-12 (Sheet 22 of 27)


CODE NO.	DIRECTIONS	WORDING
25	C-12A and C, bottom of both wings outboard of nacelles, near wing center lines, 1/2-in. and 1/4-in. yellow letters. C-12D and RC- 12D, 1/2-in. and 1/4-in. aircraft black letters.	<p style="text-align: center;">CAUTION</p> <p style="text-align: center;">USE CARE WHEN WASHING WING TO NOT REMOVE ANTI-CORROSIVE GREASE FROM WING ATTACH BOLT</p>
26	Locate on front side of nose landing gear strut 1/2-in. aircraft black letters.	MIC JACK
27	C- 12A and C, top right wing, inboard of nacelle, on access cover, 1/2-in. yellow letters. C- 12D and RC-12D, 1/2-in. aircraft black letters.	BATTERY ACCESS
28	C-12A and C, locate near fuselage on top of both wings. 3 places on right wing, 4 places on left wing. 1/2-in. yellow letters. C-12D and RC- 12D, 1/2-in. aircraft black letters.	NO STEP
29	Paint a black ground symbol, shade 37038, dimensions per ML-C-8341392.	
30	DELETE	

Figure 10-1. Exterior Markings , C-12 (Sheet 23 of 27)

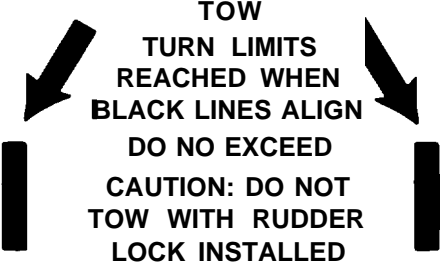
CODE NO.	DIRECTIONS	WORDING
31	C-12A and C, top of both wings inboard of nacelles, near wing centerline, 1/2-in. yellow letters above, 1/4-in. yellow letters below. C-12D and RC-12D, aircraft black letters.	<p align="center">MAIN TANK</p> <p>USE AVIATION KEROSENE OR SEE PILOTS OPERATING MANUAL FOR ALTERNATES.</p> <p align="center">CAPACITY 195 US GALLONS (USABLE 193 US GALLONS) WITH WINGS LEVEL.</p>
32	C-12A and C, top of both wings outboard of nacelles, 1/2-in. yellow letters above, 1/4-in. letters below. C-12D and RC-12D, aircraft black letters.	<p align="center">AUX TANK</p> <p>USE AVIATION KEROSENE OR SEE PILOTS OPERATING MANUAL FOR ALTERNATES.</p> <p align="center">CAPACITY 79.5 US GALLONS (USEABLE 79.0 US GALLONS) WITH WINGS LEVEL.</p>
33	Antiglare areas shall be painted aircraft black.	
34	C-12A and C, top of both wings beside inboard and outboard fuel filler caps, 1/2-in. yellow letters. C-12D and RC-12D, aircraft black letters.	FUEL
35	Paint propeller tips yellow. See Chapter 7.	
36	Locate on front of nose gear strut. Aircraft black.	<p align="center">  </p>
37	C-12A and C, locate on right side of fuselage below and aft of cargo window, 1/2-in. yellow letters. C-12D and RC-12D, 1/2-in. aircraft black letters.	<p align="center">EMERGENCY LOCATOR TRANSMITTER SWITCH</p> <p align="center">A R M —</p> <p align="center">OFF— +</p> <p align="center">O N —</p> <p>FOR AVIATION EMERGENCY USE ONLY. UNLICENSED OPERATION UNLAWFUL OPERATION IN VIOLATION OF FCC RULES SUBJECT TO FINE OR LICENSE REVOCATION.</p>

Figure 10-1. Exterior Markings, C-12 (Sheet 24 of 27)

CODE NO.	DIRECTIONS	WORDING
38	C-12A and C, locate on inboard side of RH nacelle and outboard side of LH nacelle, 1/2-in. yellow letters. C-12D and RC-12D, 1/2-in. aircraft black letters.	OIL DRAIN
39	Locate on outboard side of RH nacelle, 1/2-in. aircraft black letters.	EXTERNAL POWER RECEPTACLE 28VDC
40	C-12A and C, top of right wing, just outboard of nacelle, "ACCESS", 1/2-in. yellow letters, remainder, 1/4-in. yellow letters. C-12D and RC-12D, 1/2-in. and 1/4-in. aircraft black letters.	ACCESS DC EXTERNAL POWER RELAY DC EXTERNAL POWER CIRCUIT BREAKER
41	C-12A and C, top of right wing inboard of nacelle, "ACCESS", 1/2-in. yellow letters, remainder, 1/4-in. yellow letters. C-12D and RC-12D, 1/2-in. and 1/4-in. aircraft black letters.	ACCESS BATTERY/EMERGENCY BUS AIR CONDITIONER COMPRESSOR CLUTCH CONTROL BLEED AIR BYPASS VALVE
42	C-12A and C, right side of fuselage below and aft of cargo window, 1/2-in. yellow letters. C-12D and RC-12D, 1/2-in. aircraft black letters.	OXYGEN
43	RC-12D only, top of right wing, centered aft of engine nacelle chaff dispenser, 1/2-in. letters. "WARNING", 1/4-in. remainder, aircraft black.	WARNING SAFETY PIN MUST BE IN WHEN MODULE IS REMOVED OR INSTALLED.
44	RC-12D only, top of right wing, centered aft of engine nacelle chaff dispenser, 1/2-in. aircraft black letters.	NO FLARES
45	RC-12D only, top of left wing behind safety pin receptacle. 1/2-in. upper and 1/4-in. lower aircraft black letters.	CHAFF/FLARE SAFETY SWITCH INSERT SAFETY PIN BEFORE MODULES ARE REMOVED OR INSTALLED. CAUTION: REMOVE PIN BEFORE FLIGHT.

Figure 10-1. Exterior Markings, C-12 (Sheet 25 of 27)

CODE NO.	DIRECTIONS	WORDING
46	RC-12D only, right side of fuselage centered 1.5 in. above test connector receptacle centerline. 1/2-in. aircraft black letters.	M-1 30 TEST CONNECTOR
47	C-12A and C, bottom of both nacelles, 1/2-in. yellow letters. C-12D and RC-12D, 1/2-in. aircraft black letters.	STANDBY PUMP DRAIN
48	C-12A and C, bottom of both engine nacelles, 1/2-in. yellow letters. C-12D and RC-12D, 1/2-in. aircraft black letters.	FILTER DRAIN
49	C-12A and C, bottom of both nacelles, 1/2-in. yellow letters. C-12D and RC-12D, 1/2-in. aircraft black letters.	STRAINER DRAIN
50	C-12A and C, bottom of both wings, inboard of nacelles near fuselage, and outboard of nacelles, 1/2-in. yellow letters. 4 required. C-12D and RC-12D, 1/2-in. aircraft black letters	FUEL DRAIN
51	C-12A and C, bottom aft ends of both engine nacelles, 1/2-in. yellow letters. C-12D and RC-12D, 1/2-in. aircraft black letters.	GRAVITY LINE DRAIN
52	Do not paint these areas.	
53	Left side of aircraft aft of cabin door, 1/2-in. aircraft black letters.	PRESSURIZED
54	Locate under access plates on top and bottom of both wings near inboard and outboard wing mating surfaces. "WARNING", 1/2-in. aircraft black letters, remainder, 1/4-in. aircraft black letters. See Detail A.	<p style="text-align: center;">WARNING</p> <p style="text-align: center;">LUBRICATED BOLTS</p> <p style="text-align: center;">-----</p> <p style="text-align: center;">-----</p> <p style="text-align: center;">SEE MAINT. MANUAL FOR TORQUE VALUES</p>
55	C-12D and RC-12D only. Top left side of nose, 1/2-in. aircraft black letters.	SIGHT GAUGE
56	RC-12D only. Left wing just outboard of engine nacelle, near leading edge, 1/2-in. aircraft black letters.	<p style="text-align: center;">ACCESS</p> <p style="text-align: center;">AC EXTERNAL POWER RELAY</p> <p style="text-align: center;">AC EXTERNAL POWER</p> <p style="text-align: center;">CIRCUIT BREAKER</p>

Figure 10-1. Exterior Markings, C-12 (Sheet 26 of 27)

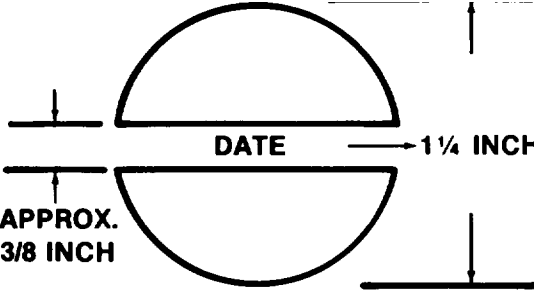
CODE NO.	DIRECTIONS	WORDING
57	RC-12D only. Top of left wing just outboard of engine nacelle near wing centerline. 1/2-in. aircraft black letters.	<p>ACCESS INVERTER 115 VAC 30</p>
58	Inboard bottom of left wing near fuselage and leading edge, 1/2-in. aircraft black letters.	<p>ACCESS BLEED AIR BYPASS VALVE AVIONIC INVERTER & CONTROL RELAY</p>
59	C-12D and RC-12D only. LH, fwd fuselage, below Code No. 14, 1/2-in. aircraft black letters. Note: Date shown on stencil is date aircraft painted with MIL-C-46168 paint.	 <p>The diagram shows a semi-circular stencil marking. The word "DATE" is centered within the semi-circle. A horizontal dimension line to the right of the semi-circle indicates a width of 1 1/4 INCH. A vertical dimension line to the left of the semi-circle indicates a height of APPROX. 3/8 INCH. There are also vertical dimension lines above and below the semi-circle, and horizontal lines extending from the top and bottom edges of the semi-circle.</p>
60	RC-12D only. Bottom, outboard side of left engine nacelle. 1/2-in. aircraft black letters.	<p>EXTERNAL POWER RECEPTACLE 115VDC</p>

Figure 10-1. Exterior Markings, C-12 (Sheet 27 of 27)

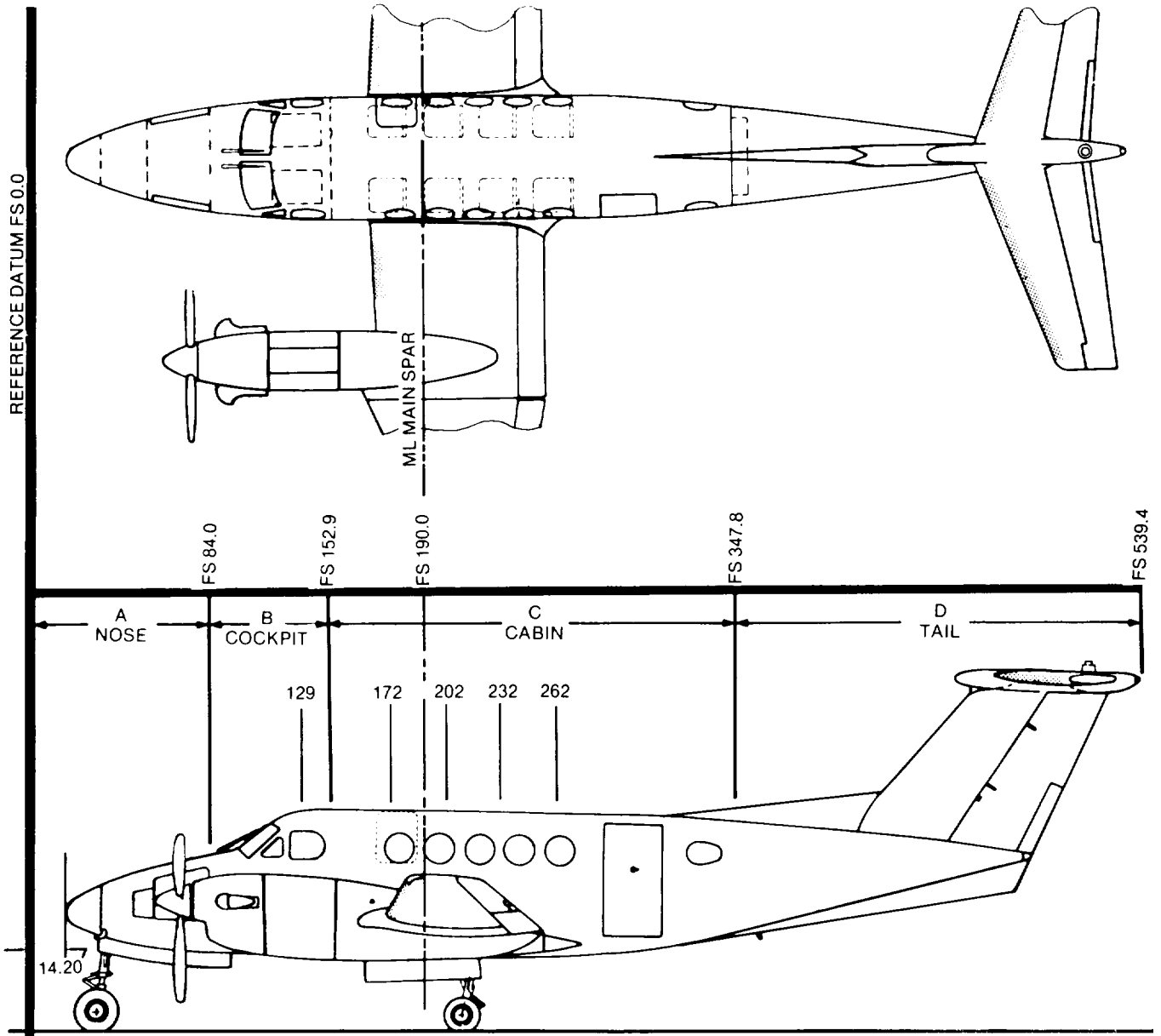
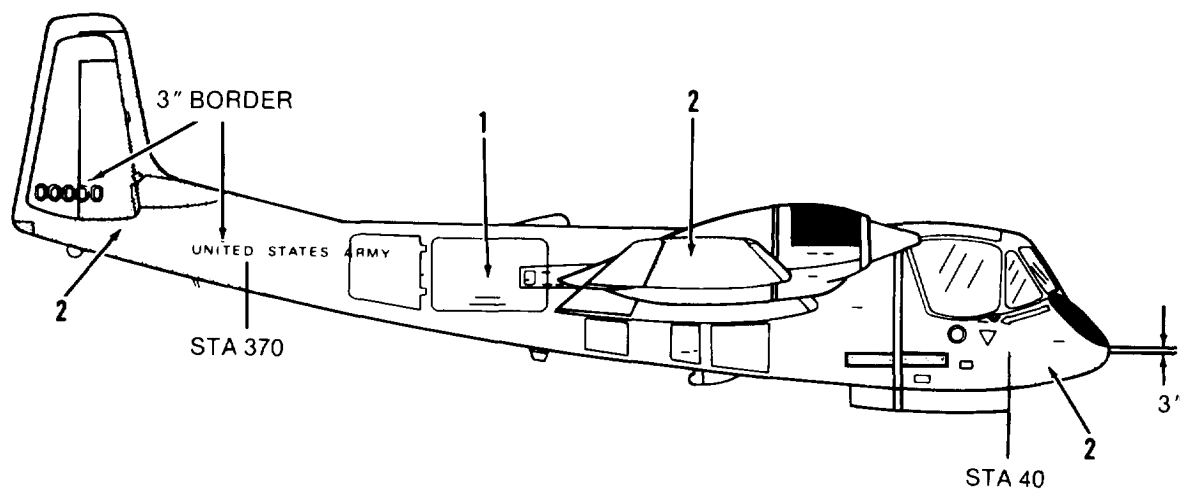


Figure 10-2. Station Diagram, C-12

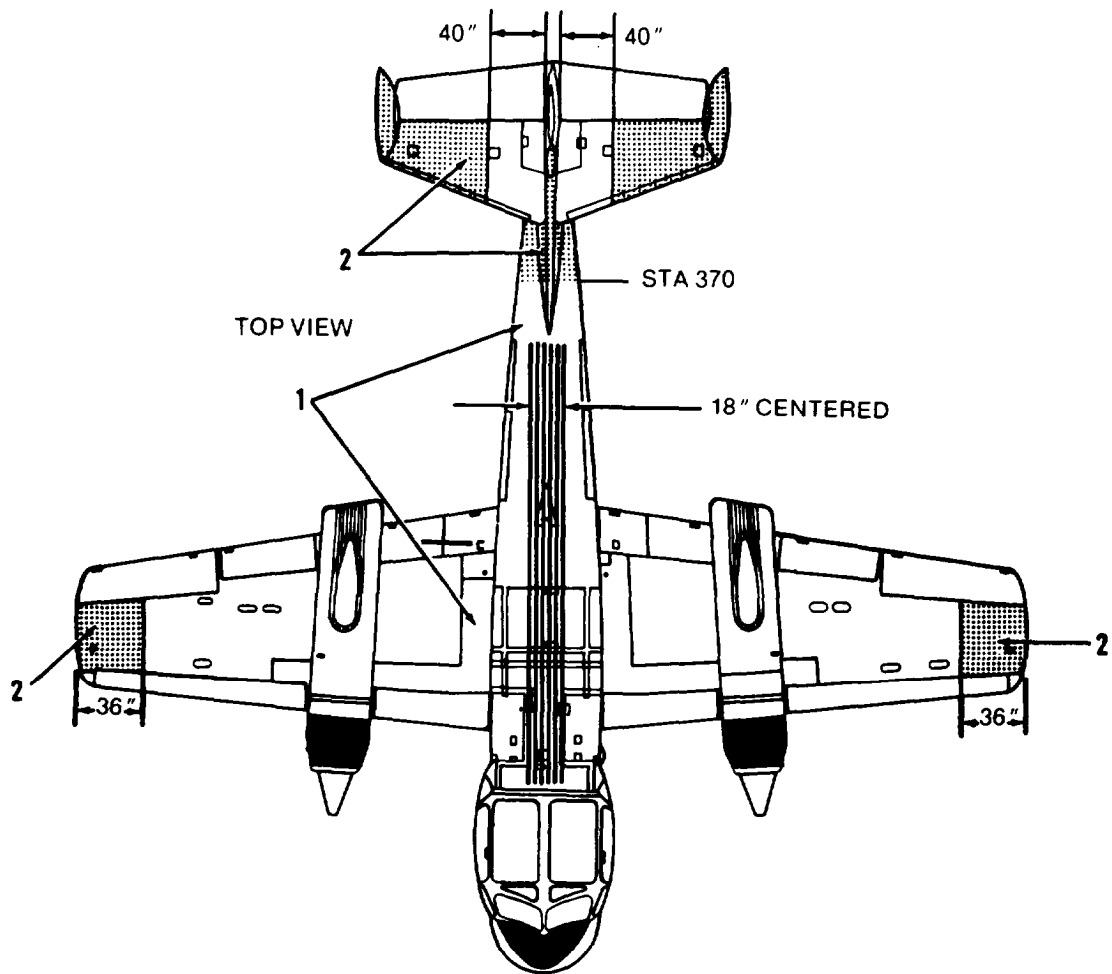
Section III. OV-1 and RV-1 ILLUSTRATIONS



1. MIL-C-46168, aircraft exterior gray (entire aircraft, except as noted).

MIL-P-21600, fluorescent red-orange, ANA #633 (training aircraft-high visibility, only where authorized).

Figure 10-3. Tactical Paint Scheme, OV-1D and RV-1D (Sheet 1 of 2)



1. MIL-C-46168, aircraft exterior gray (entire aircraft, except as noted).
2. MIL-P-21600, fluorescent red-orange, ANA #633 (training aircraft-high visibility, only where authorized).

Figure 10-3. Tactical Paint Scheme, OV-1D and RV-1D (Sheet 2 of 2)

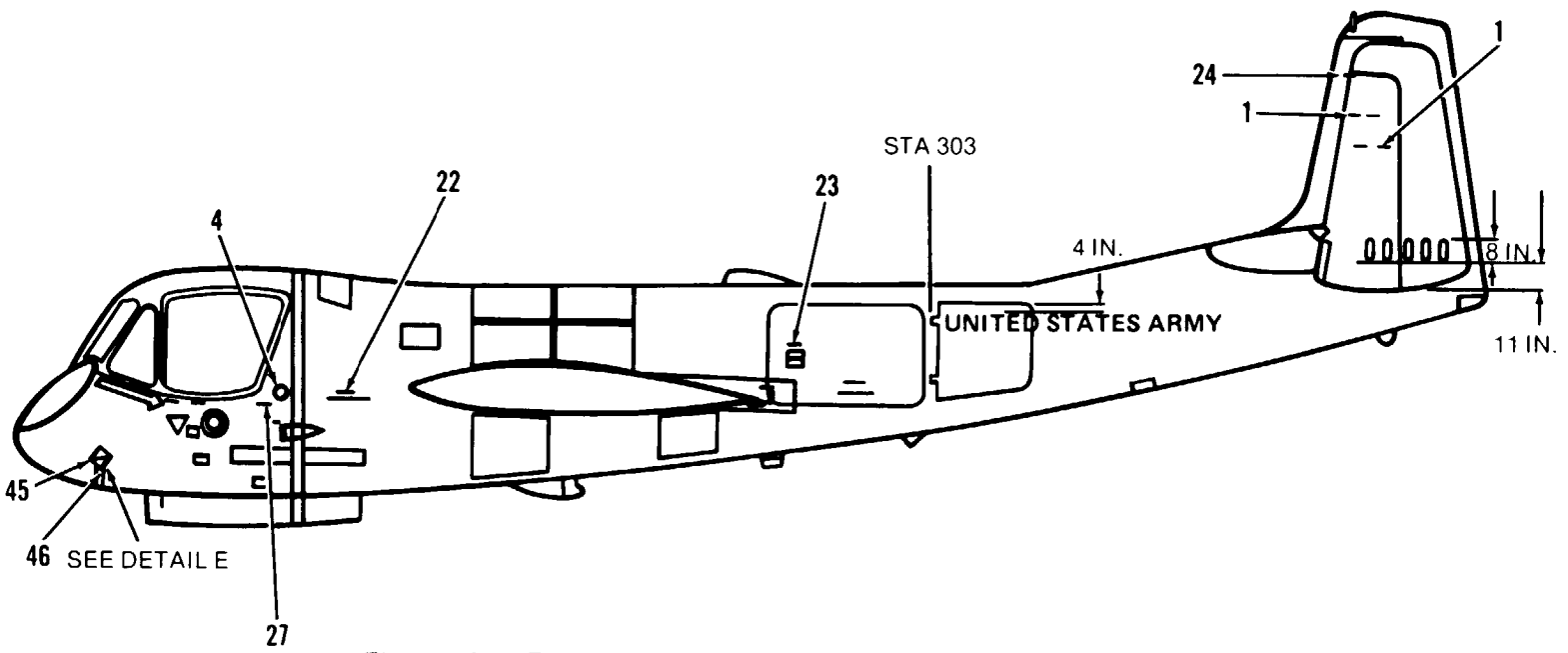
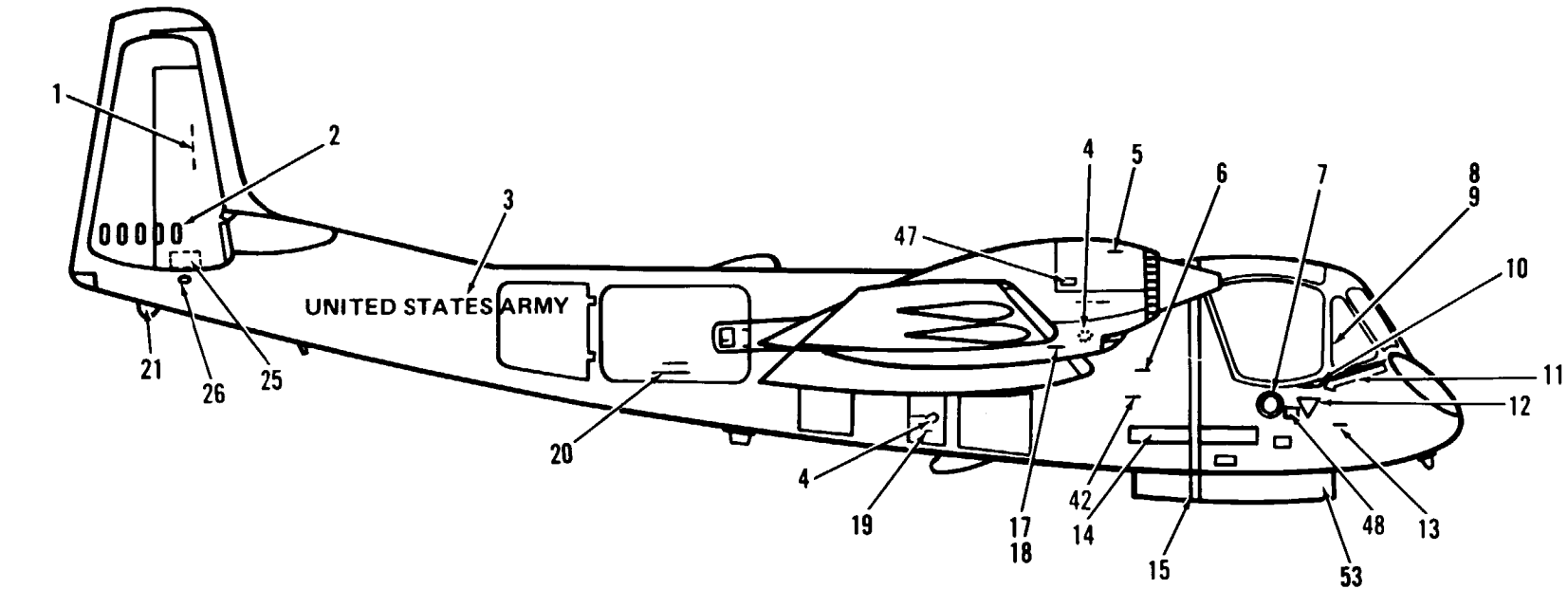


Figure 10-4. Exterior Markings, OV-1D and RV-1D (Sheet 1 of 15).

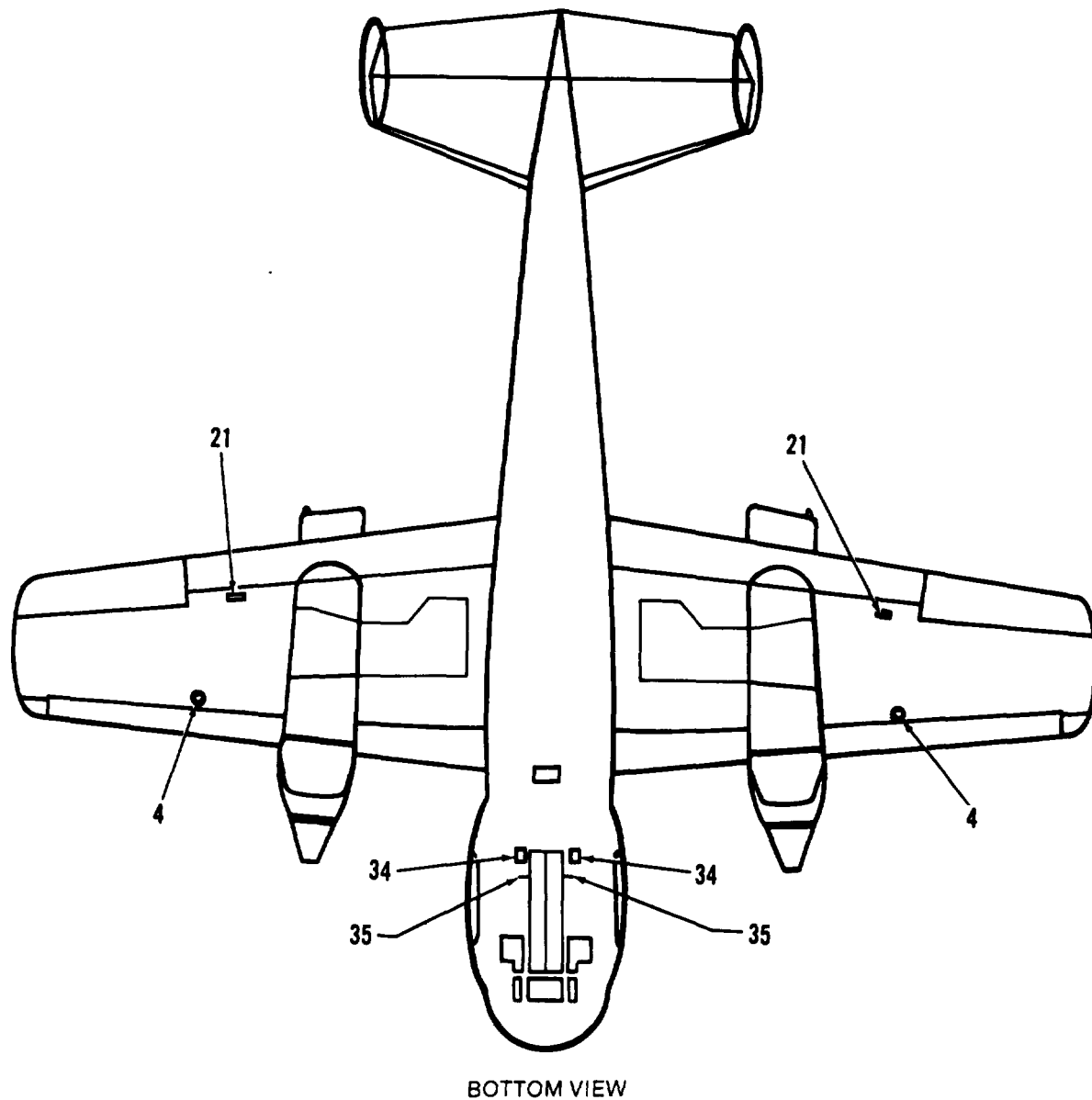


Figure 10-4. Exterior Markings, OV-1D and RV-1D (Sheet 3 of 15).

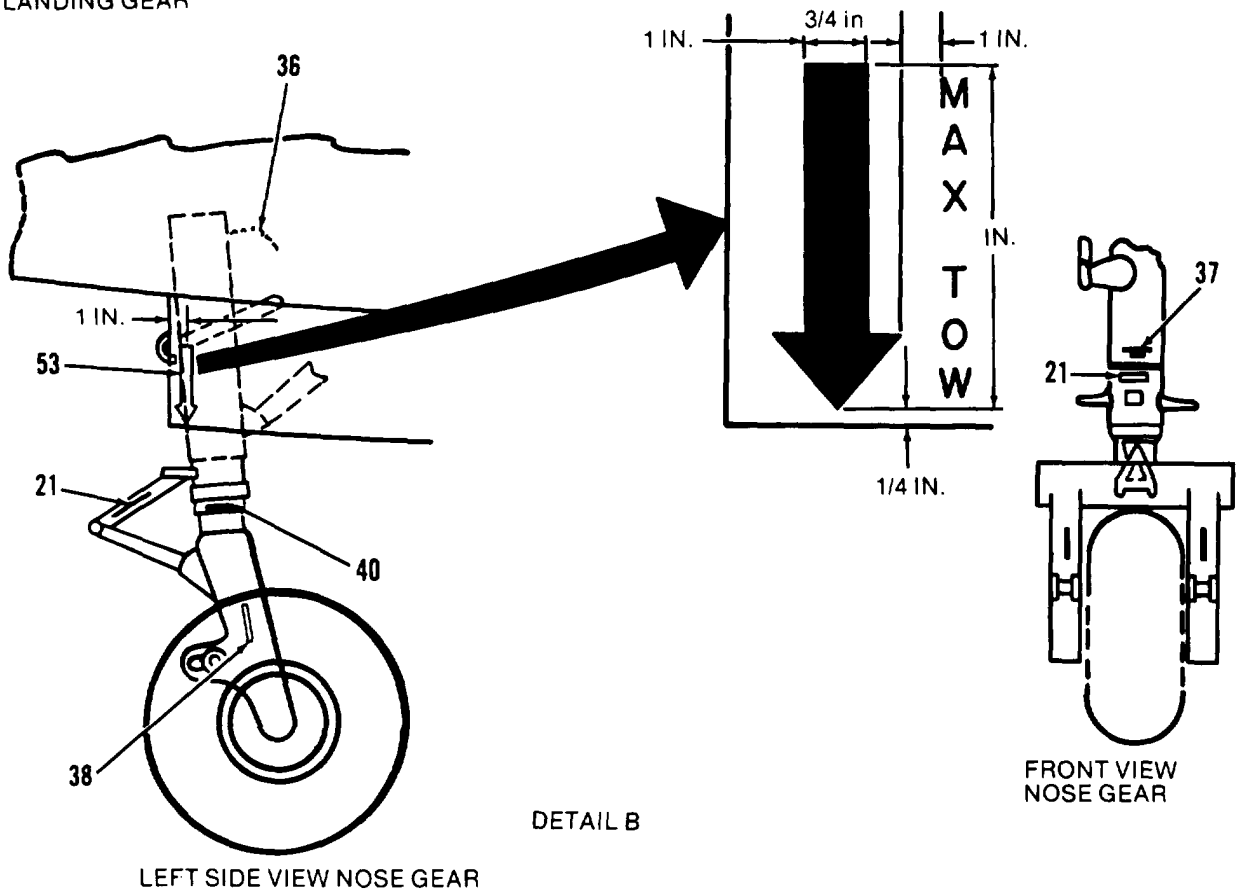
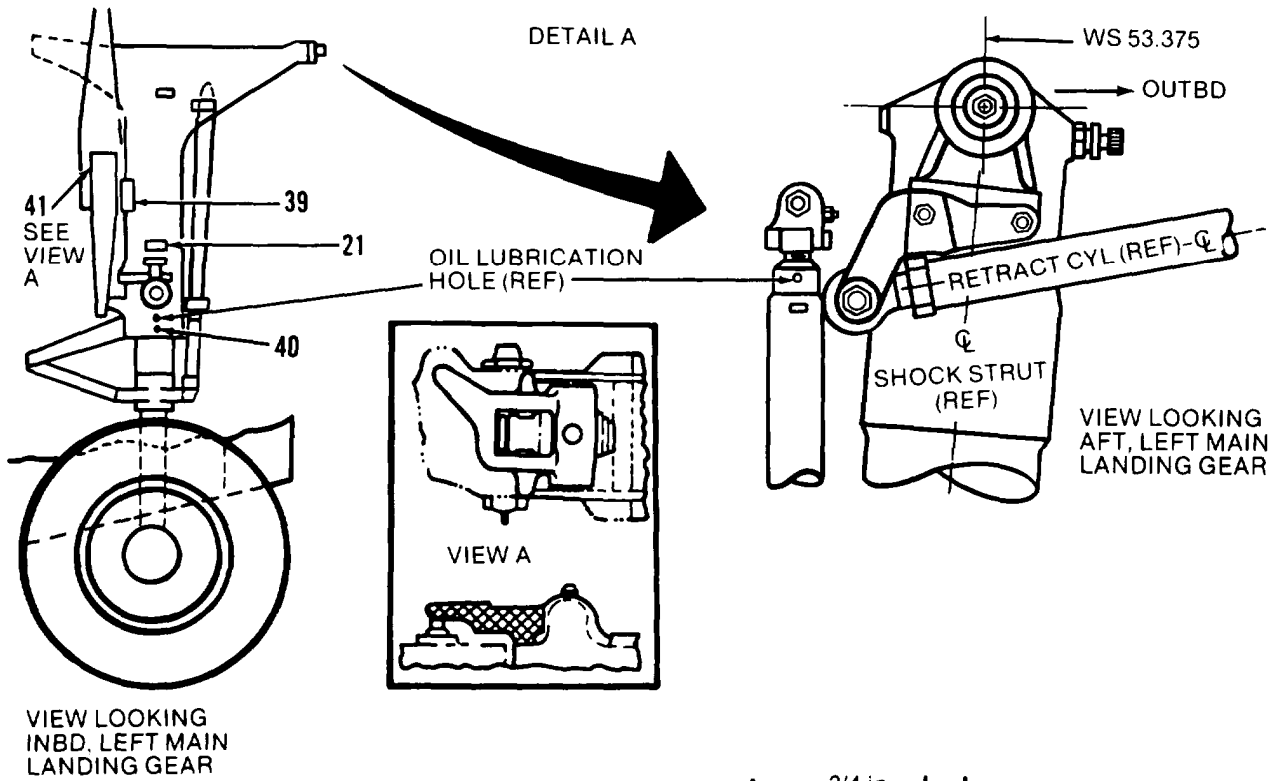


Figure 10-4. Exterior Markings, OV-1D and RV-1D (Sheet 4 of 15).

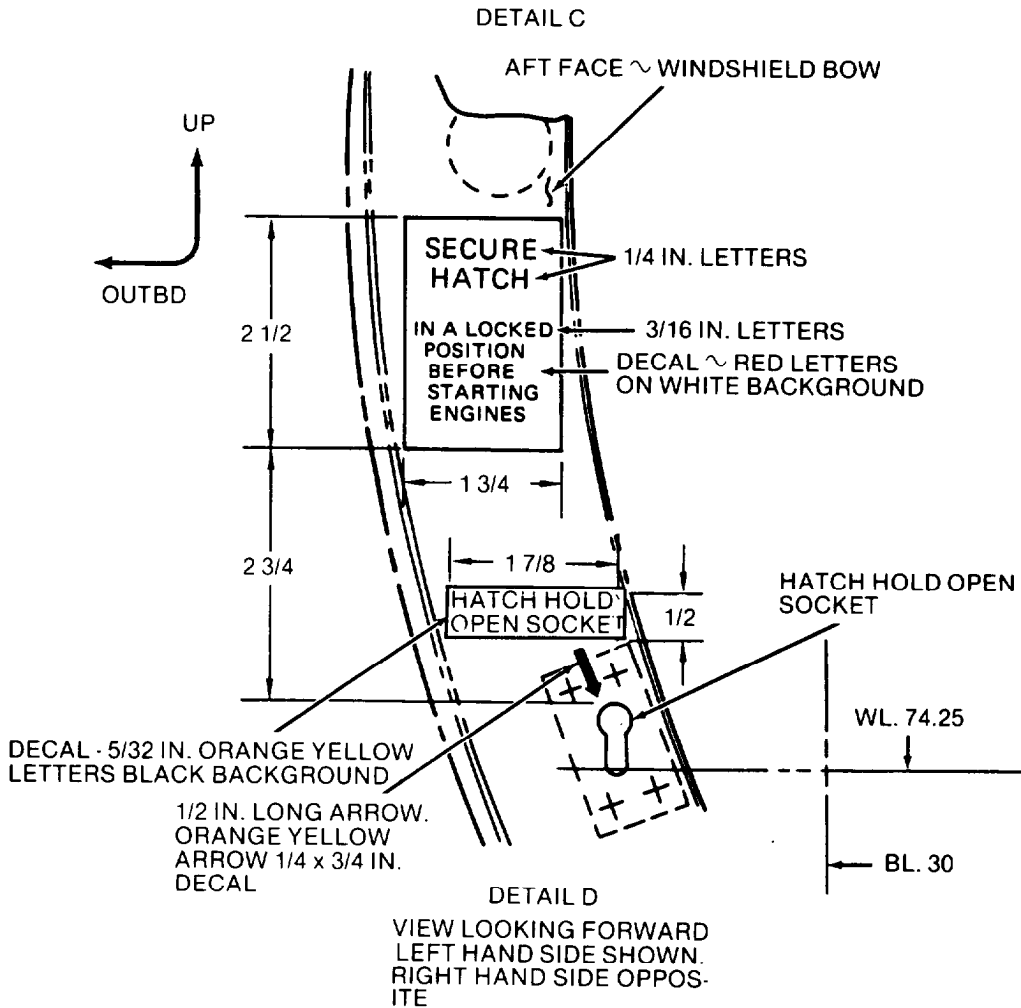
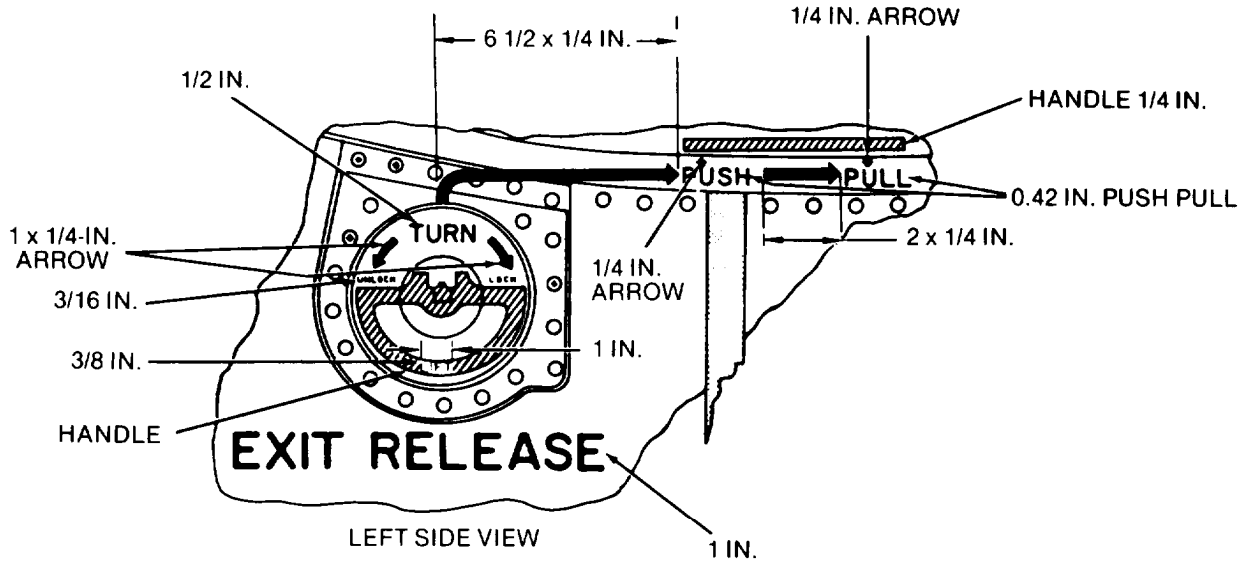


Figure 10-4. Exterior Markings, OV-ID and RV-1D (Sheet 5 of 15)



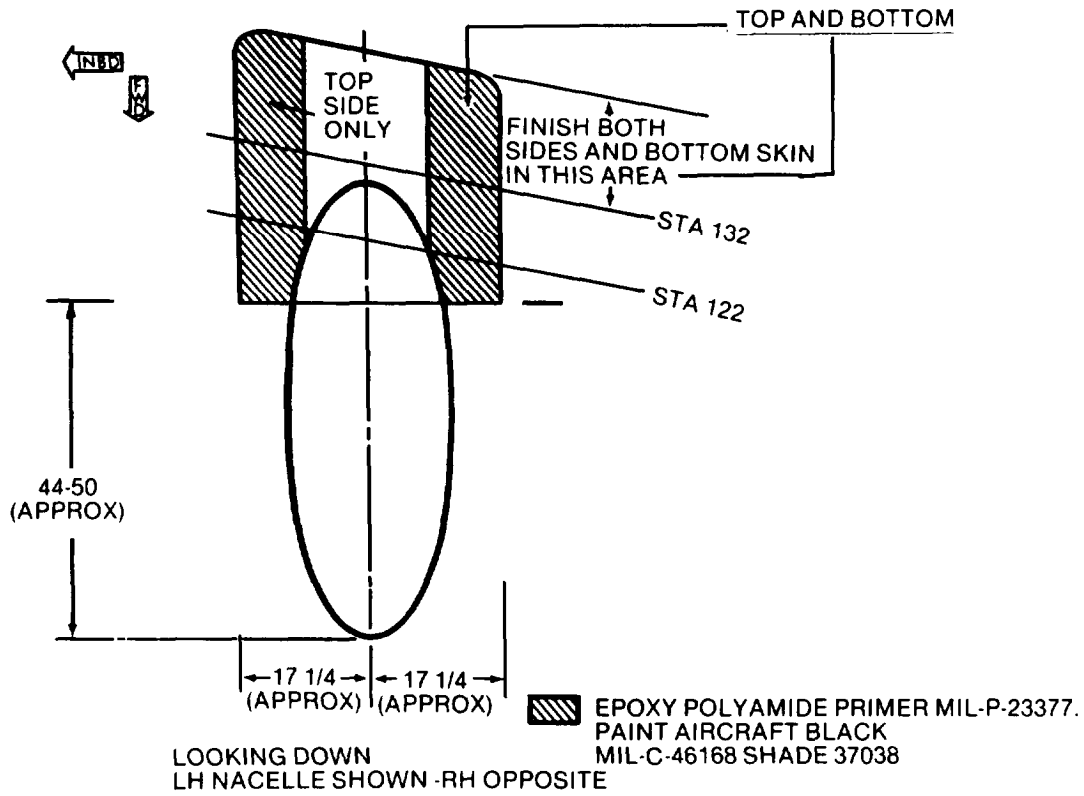
DETAIL E

Hazard Warning Decal

Notes:

1. 1/4-in. aircraft black letters on exterior aircraft gray background (upper section)
2. 1/4-in. exterior aircraft gray letters on aircraft black background (lower section)
3. Word WARNING. 1/2-in aircraft black letters

Figure 10-4. Exterior Markings, OV-1D and RV-1D (Sheet 6 of 15).

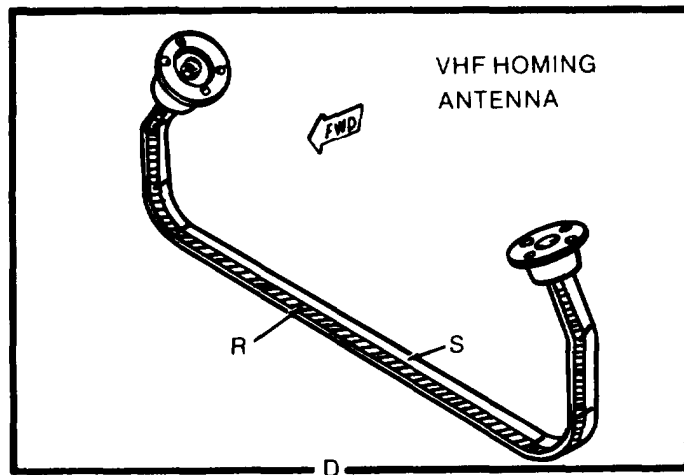
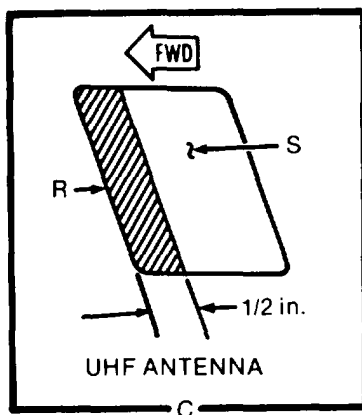
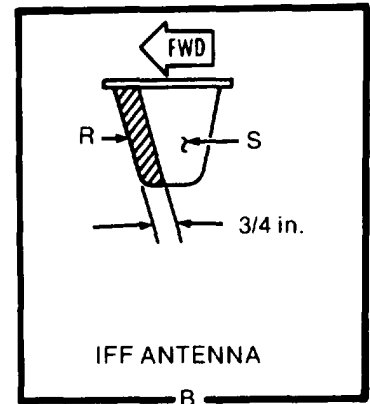
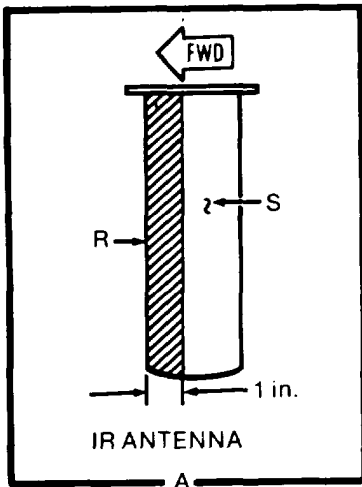
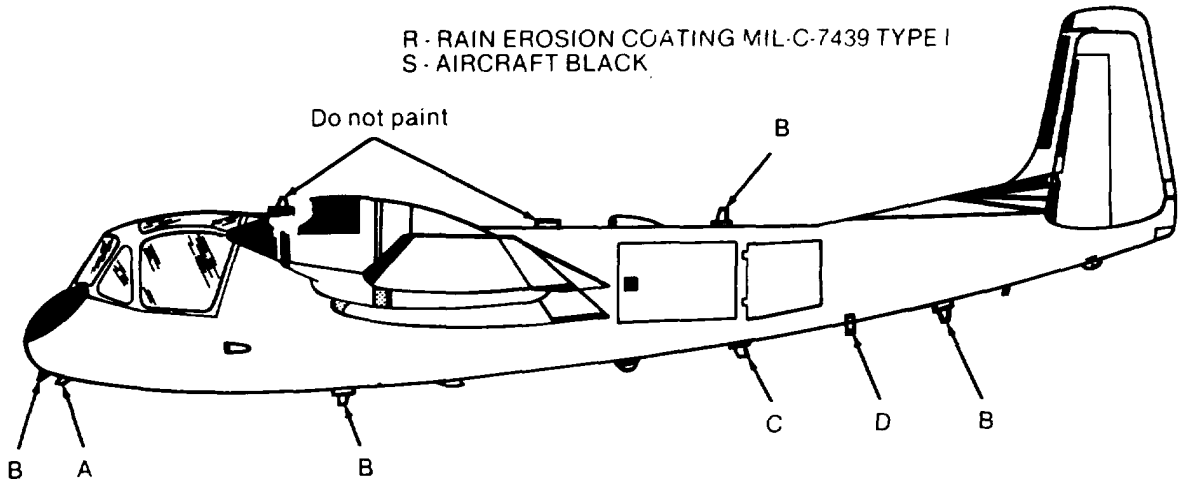


DETAIL F
Nacelle LSSS Markings

Figure 10-4. Exterior Markings, OV-1D and RV-1D (Sheet 7 of 15).

FINISH CODE

R - RAIN EROSION COATING MIL-C-7439 TYPE I
 S - AIRCRAFT BLACK



DETAIL G

Figure 10-4. Exterior Markings, OV-1D and RV-1D (Sheet 8 of 15).


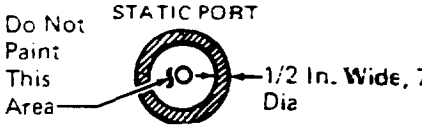
CODE NO.	DIRECTIONS	WORDING
1	Left and right side of center fin, 1/2-in. MIL-C-46168, aircraft black #37038 letters, 3 places.	CAUTION, USE NON-MAGNETIC SCREWS
2	Tail fin. Black radio call numbers are on the outboard side of outboard tail fins. Bottom of 8-in. numbers is 11 in. from bottom of tail fin.	(00000)
3	Both sides of fuselage. Center as nearly as possible between wing trailing edge and aft end of aircraft. 6-in. black letters.	UNITED STATES ARMY
4	Fuselage and wings, 5 places. Paint black shade 37038, dimensions per MIL-C-83413/9-2.	
5	Outboard side of right nacelle and inboard side of left nacelle. 1/2-in. black letters.	OIL FILLER INSIDE MIL-L-23699 ABOVE -25° F MIL-L-7808 BELOW -25° F
6	Right side of aircraft under louvered opening, above hydraulic test access door. 1/2-in. black letters.	HEAT EXCHANGER EXHAUST KEEP CLEAR
7	Both sides of fuselage. 1/2-in. black letters centered on station 63.50, WL 54.00.	
8	Both sides of fuselage, 1/4-in. black letters. See Detail D	SECURE HATCH IN A LOCKED POSITION BEFORE STARTING ENGINES
9	Both sides of fuselage, 5/32-in. black letters. See Detail D	HATCH HOLD OPEN SOCKET
10	Both sides of fuselage, Exit release. (See detail C)	

Figure 10-4. Exterior Markings, OV-1D and RV-1D (Sheet 9 of 15)

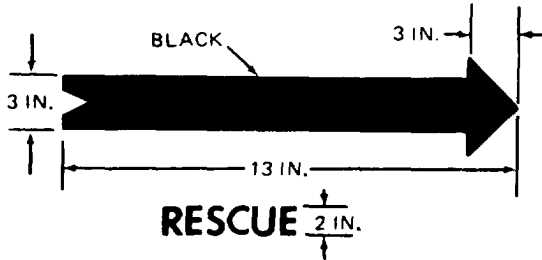
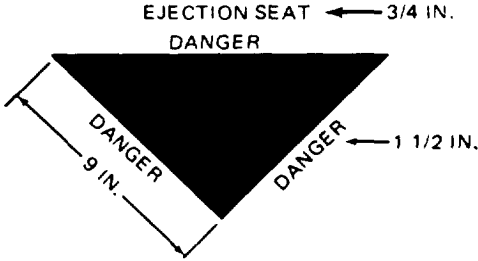
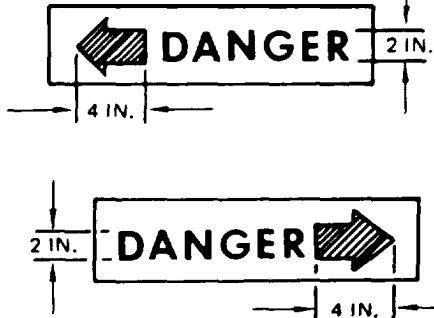
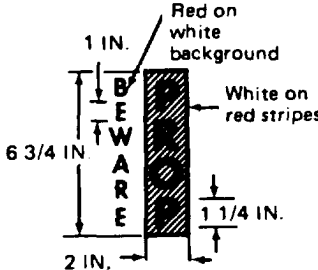
CODE NO.	DIRECTIONS	WORDING
11	Each side of fuselage, left side shown.	
12	Both sides of fuselage, 9 in. black equilateral triangle, letter size as shown.	
13	Right side of forward fuselage 1/2-in. black letters.	<p>WINDSHILED WASHER — FILL WITH WATER OR ALCOHOL TT-I-735 (ISOPROPYL), MIL-A-6091 (ETHYL), O-M-232 (METHYL) CAP. 3.0 GAL</p>
14	Left and right side of fuselage. Fwd and aft of propeller warning stripe. MI L-C-46168, exterior aircraft gray on black background.	
15	Propeller warning is located inside both nose wheel doors. Paint red No. 11136 and white No. 17875.	

Figure 10-4. Exterior Markings, OV-1D and RV-1D (Sheet 10 of 15)


CODE NO.	DIRECTIONS	WORDING
16	A 3 in. black stripe encircling fuselage and down nose wheel doors. Black stripe starts at fuselage station 89.5 and extends 3 in. aft.	
17	Outbd side of each nacelle fwd of push-in door. Letters are fwd of door with arrow pointing toward door. 1/2-in. black letters.	EXTINGUISHER. NOZZLE  RECEPTACLE
18	Left aft equipment access panels, outboard side of each nacelle. Letters will be 1/2-in. exterior aircraft gray on aircraft black background.	PUNCH IN
19	Right side of fuselage and top of fuselage, 1/2-in. black letters.	MIL-T-5624 (JP-4) 297 U.S. gal.
20	Left and right side of fuselage on equipment access door 2-in. black letters.	BEWARE JET BLAST
21	Bottoms of wings and sides of aft fuselage (4 places, 1/2-in. black letters). Front of nose landing gear and outboard sides of main landing gear struts (3 places, 1/2-in. black letters.)	TIE DOWN
22	Left side of fuselage, forward of wing leading edge. Top of letters will be in line with bottom of wing. First two lines are 1 in. letters with 1 in. spacing between lines. All other letters are 1/2-in. with 1/2-in. spacing between lines. Paint black.	U.S. ARMY (OV-1D or RV.1D, as req'd) U.S.A. SERIAL NO. 00000 FOR EMERGENCY ALTERNATE FUEL REFER TO TM55-1510.2I3.10
23	Left side of fuselage on access panel, 1/2-in. black letters.	EMERGENCY BATTERY ACCESS
24	Left side of center fin., 1/2-in. black letters,	COMPASS MAG DET
25	Aircraft finish identification is located on the right side of aft fuselage. 1/4.in. black letters. ** Contractor will insert their name code.	** WP1-P2-L3 Date WP - indicates wash primer used P - indicates primer used L - indicates lacquer used (if req'd) C - indicates coating used (if req'd)

Figure 10-4. Exterior Markings, OV-1D and RV-1D (Sheet 11 of 15)

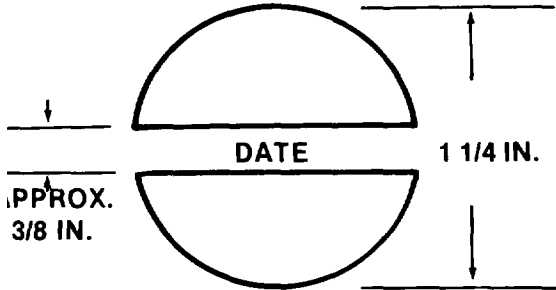
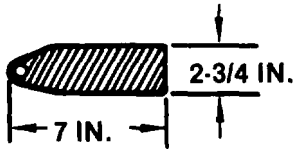
CODE NO.	DIRECTIONS	WORDING
26	Stencil on right side of aft fuselage, below Code 25. Paint black. Note: Date shown on stencil is date aircraft painted with MIL-C-46168 coating.	
27	Left side of fuselage below cockpit window, 1/2-in. black letters.	OXYGEN FILLER-FILL WITH OXYGEN, MIL-O-27210, TYPE 1, CHARGE TO 1800 P.S.I. PER BOTTLE
28	Top trailing edge of wing control and flap surface, 12 places, 1/2-in. black letters.	NO PUSH
29	Top of each nacelle, forward of exhaust port. Top of letters facing aft, 1/2-in. black letters.	WARNING NO STEP IN SHROUD OR SURROUNDING AREA
30	Top of wings, fuselage, and nacelles 1/2-in. black letters, 28 required.	NO STEP
31	Forward of nacelle on the after body just below the Filler access door, 1/2-inch aircraft black letters.	FILL WITH MIL-H-5606
32	Top of fuselage. Top of letters facing forward, aft of warning stripe. Letter size is 1/2-in. black except "WARNING" and "KEEP CLEAR" are 1 in.	WARNING PNEUMATIC EMERGENCY CANOPY JETTISON - KEEP CLEAR
33	Locate on fuel access door, 1-in. black letters. Also, 1 in. black band around door.	FUEL
34	Bottom of aircraft, area around and aft of each relief tube drain. Apply MIL-P-15930 primer, cover with two coats black MIL-E-15936.2 places.	
35	Two places bottom of fuselage, forward of relief tube drain, 1/2-in. black letters, 2 places	RELIEF TUBE OUTLET

Figure 10-4. Exterior Markings, OV-1D and RV-1D (Sheet 12 of 15)


CODE NO.	DIRECTIONS	WORDING
36	Two places on nose gear linkage 3/8-in. letters, black on white background (See detail B).	
37	Across front of nose gear oleo strut above shimmy damper casting, 1/2-in. black letters (See detail B)	<p>TIRE PRESSURE 65 PSI</p>
38	On each side of nose gear strut. Vertical letters near towing eye. 1/2-in. letters are black (See detail B)	<p>T O W H E R E</p>
39	On forward side of each main landing gear strut. Letters will be 1/2-in. black and vertical on each gear (See detail A)	<p>T I R E P R E S S U R E 100 PSI</p>
40	Two places on each main gear, one place on nose gear. Opposite NAS 516 Lub fittings, 1/4-in. black letters. (See detail A.)	<p>FILLER WITH MIL-H-5606 ONLY</p>
41	Paint side brace on the heavy outline (shaded area, detail B, view A) with one coat of MIL-C-46168, aircraft white #37875 and final finish of MIL-P-21600 fluorescent red-orange #633 in accordance with procedure MIL-P-21698.	

Figure 10-4. Exterior Markings, OV-1D and RV-1D (Sheet 13 of 15)

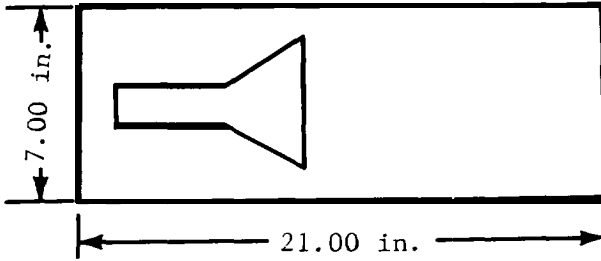
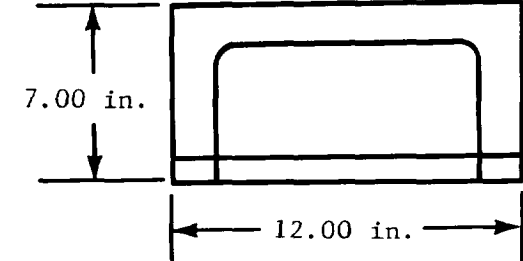
CODE NO.	DIRECTIONS	WORDING
42	Right side of fuselage on hydraulic filler door. 1/2-in. black letters	SERVICE WITH MIL-H-83282 ABOVE -40° F.
43	Top nose of fuselage. Last three digits of aircraft serial number. 8-in. black numbers.	(000)
44	Left side, outside of canopy frame, 6 in. from forward end. 1-in. black numbers, aircraft serial number.	(00000)
45	Forward fuselage. Both sides. Radiation. Warning Decal. See Detail E.	
46	Forward fuselage. Both sides 1.0 in black stripe, 22 in. long from antenna base to radiation warning decal.	
47	Inboard and outboard side of each engine nacelle. Paint entire area black.	
48	Both sides of fuselage. Paint entire area black.	
49	Paint 4 in. of tip of propeller blades (forward face only) with MIL-F-18264, orange-yellow #13538.	
50	Nacelle areas. Unsuppressed LSSS configuration. See detail F.	

Figure 10-4. Exterior Markings, OV-1D and RV-1D (Sheet 14 of 15)


CODE NO.	DIRECTIONS	WORDING
51	Top of fuselage and wings. Walkway area. Paint with MIL-W-5044A, Type I, Class I. Black #604.	
52	Antennas. See Detail G. Surfaces marked with R shall be finished with rain resistant coating. MIL-C-7439B, Class II. S surfaces shall be finished with black paint, #37038, MIL-L-81352.	
53	On outboard side of each nose wheel door. 1 in. aft of leading edge of door. (See detail B) BLACK ARROW BLACK LETTERS	

Figure 10-4. Exterior Markings, OV-1D and RV-1D (Sheet 15 of 15)

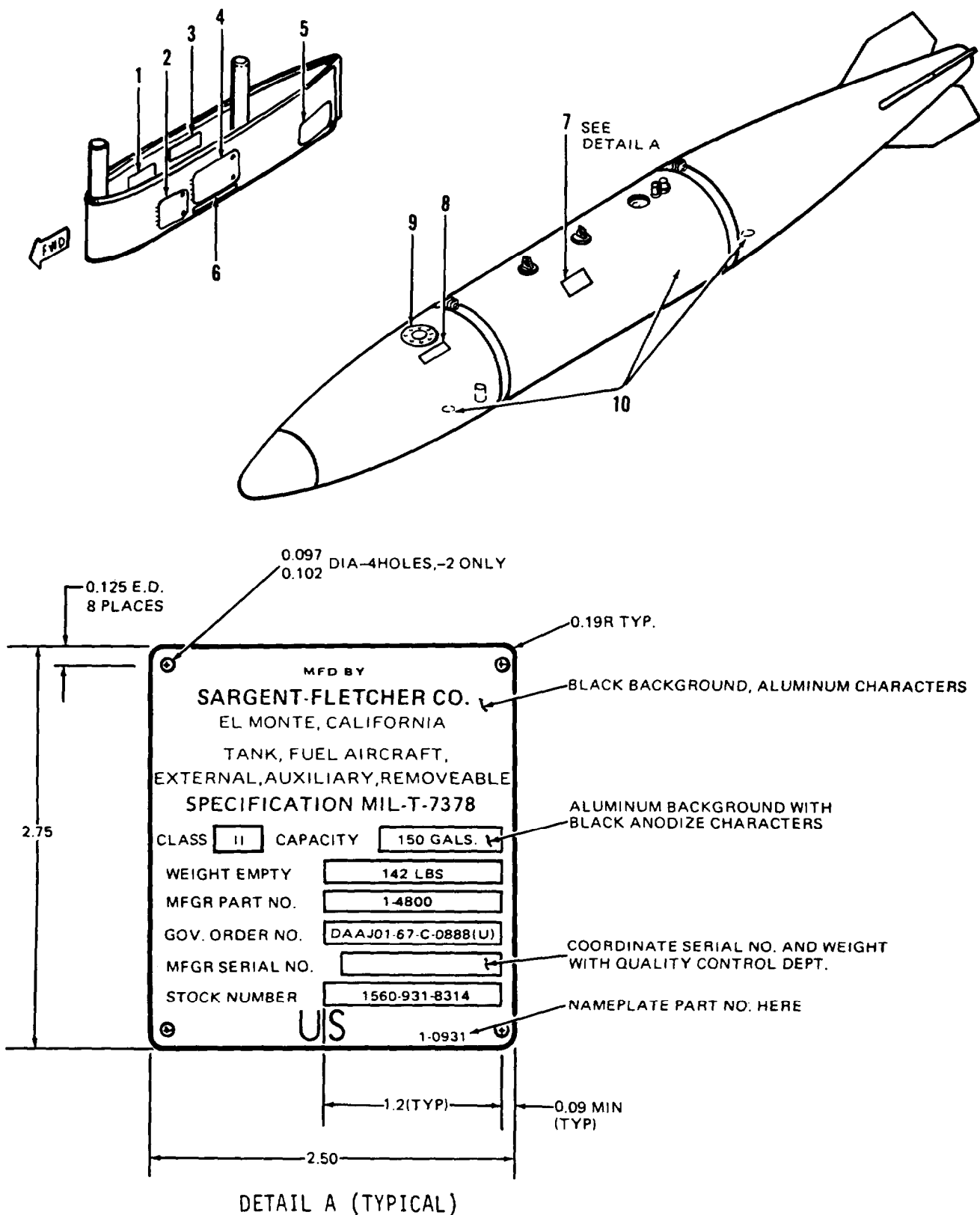


Figure 10-5. Aero 65 Bomb Rack and External Fuel Tank Markings, OV-1 (Sheet 1 of 4).

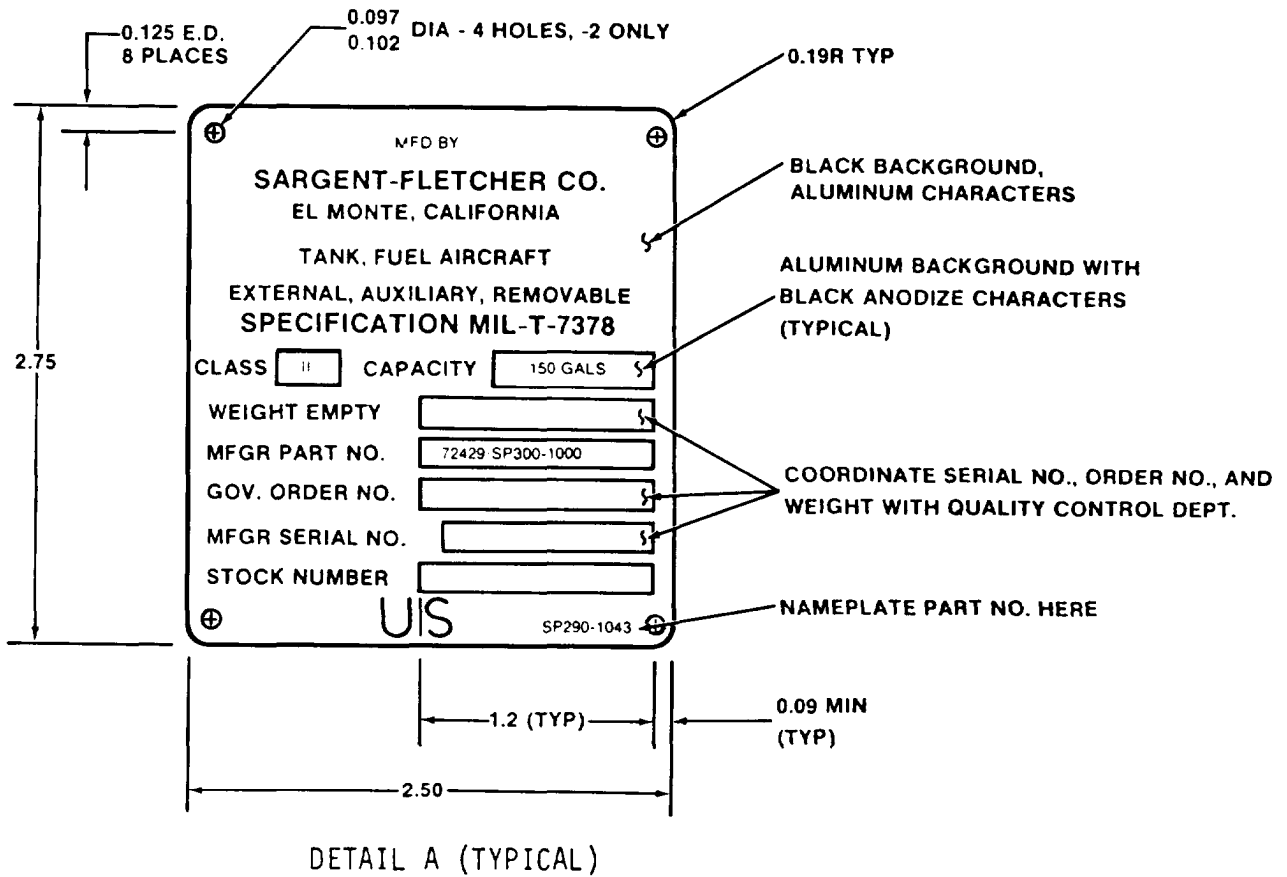
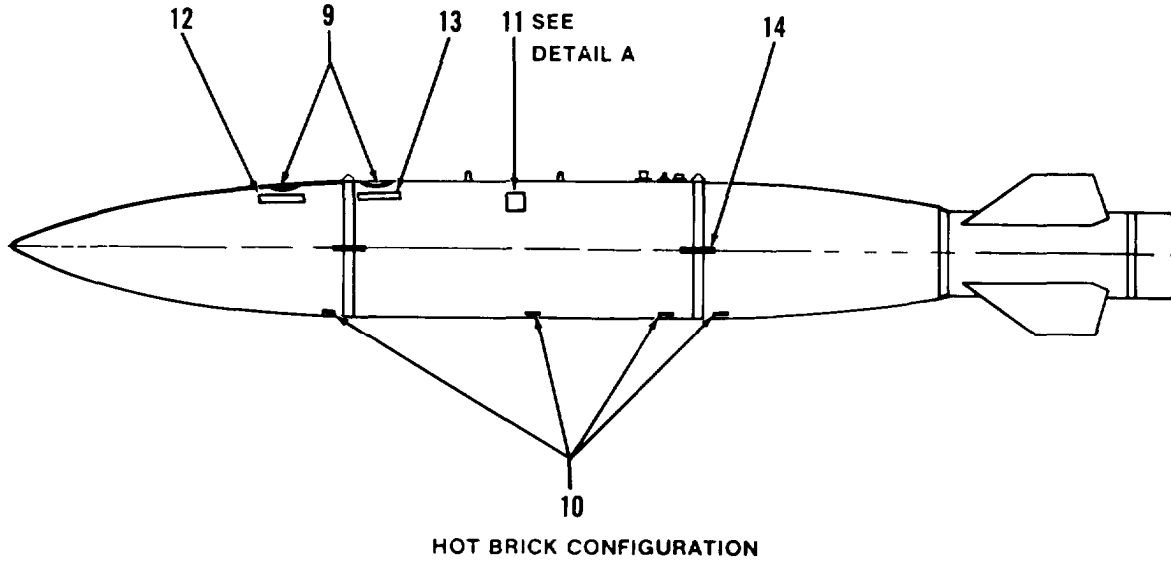


Figure 10-5. Aero 65 Bomb Rack and External Fuel Tank Markings. OV-1 (Sheet 2 of 4).

CODE NO.	DIRECTIONS	WORDING
1	Stencil 1/2-in., MIL-C46168, aircraft black #37038 letters.	RACK ELECTRICAL HOISTING ACCESS
2	Stencil 1/2-in. aircraft black letters.	RACK ELECTRICAL HOISTING ACCESS
3	Stencil 1/2-in. aircraft black letters.	RACK ELECTRICAL HOISTING ACCESS
4	Stencil 1/2-in. aircraft black letters.	RACK LATCHING SAFETY PIN EJECTION ACCESS
5	Stencil 1/2-in. aircraft black letters.	TANK CONNECTION ACCESS, STOW CONNECTORS ADAPTERS WHEN NOT IN USE
6	Stencil 1/4-in. aircraft black letters.	ALIGN RED MARKS BEFORE PULLING PIN
7	See Detail A. Locate on side of fuel tank below and between suspension lugs.	
8	Stencil 1/2-in. aircraft black letters.	GRADE JP-4 FUEL
9	DELETE	
10	Stencil 1/2-in. aircraft black letters.	DRAIN

Figure 10-5. Aero 65 Bomb Rack and External Fuel Tank Markings, OV-1 (Sheet 3 of 4)


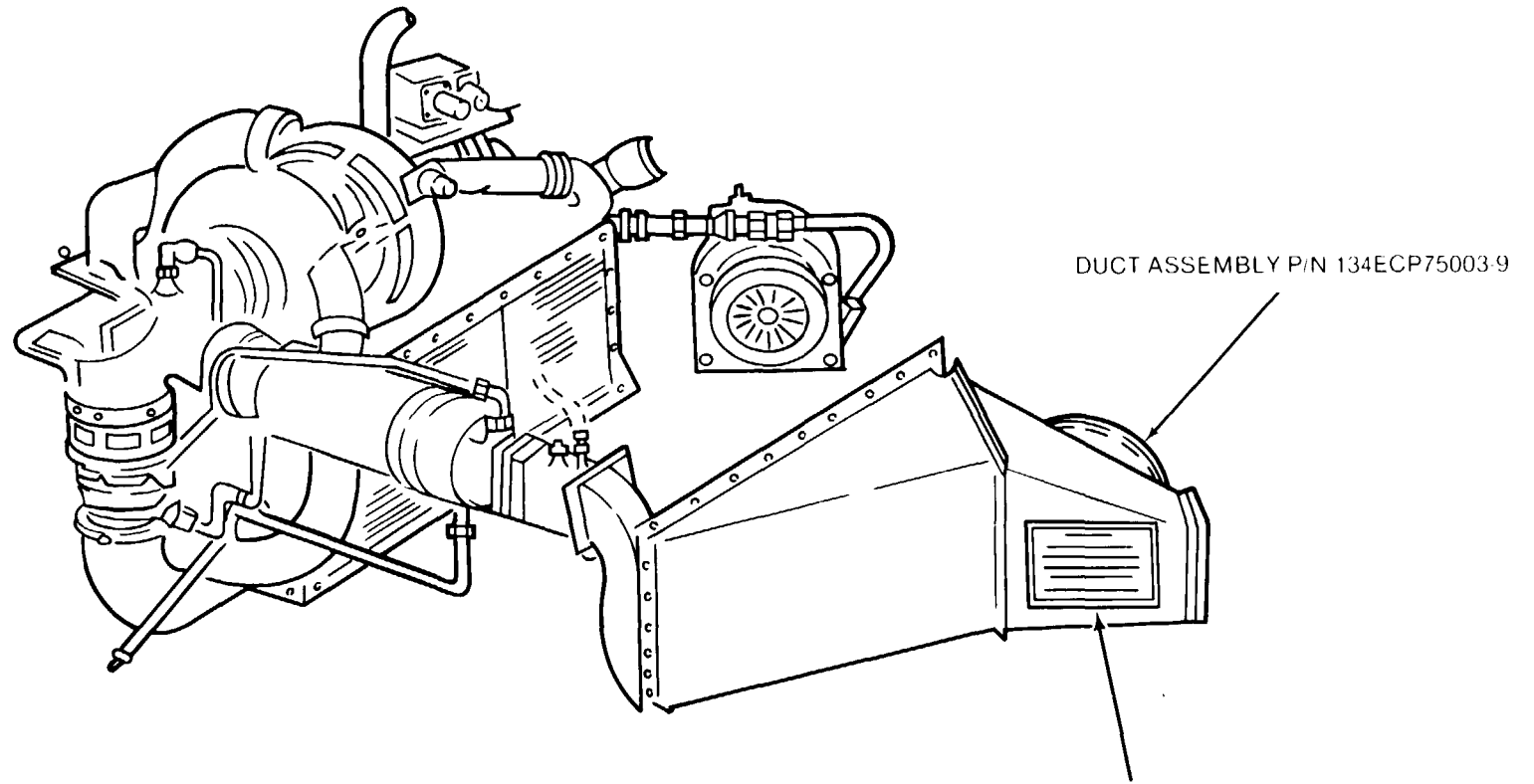
CODE NO.	DIRECTIONS	WORDING
11	Locate on side of fuel tank below and between suspension lugs (SEE DETAIL A).	
12	Stencil 5 in. aircraft black letters.	CAPACITY 150 U.S. GAL., 125 IMP. GAL. USE GRADE JP-4 FUEL, NATO NO. F.40
13	Stencil 5 in. aircraft black letters.	CAPACITY 12 U.S. GAL., 10 IMP. GAL. USE GRADE JP-4 FUEL, NATO NO. F.40
14	Alignment stripe. two places each side. 1/4 in. wide. 4.3 in. length, center across tank joints. Aircraft black.	

Figure 10-5. Aero 65 Bomb Rack and External Fuel Tank Markings, OV-1 (Sheet 4 of 4)



Notes:

1. Lightly sand stencil surface and apply 1 coat primer, MIL-P-23377.
2. Apply 1 coat (approx. 4 x 6 inches) aircraft red, MIL-C-46168, shade 31136.
3. Apply lettering, aircraft white, MIL-C-46168, shade 37875

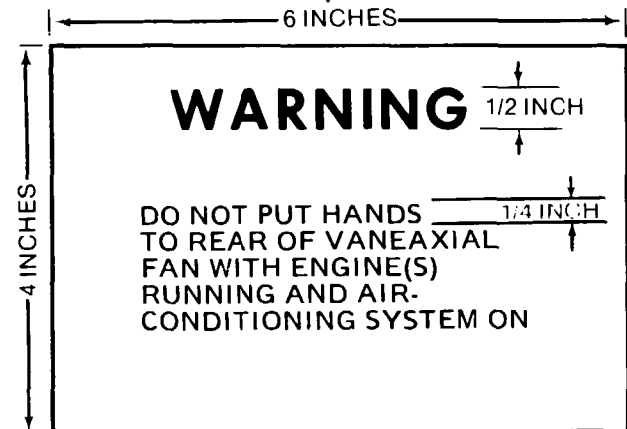
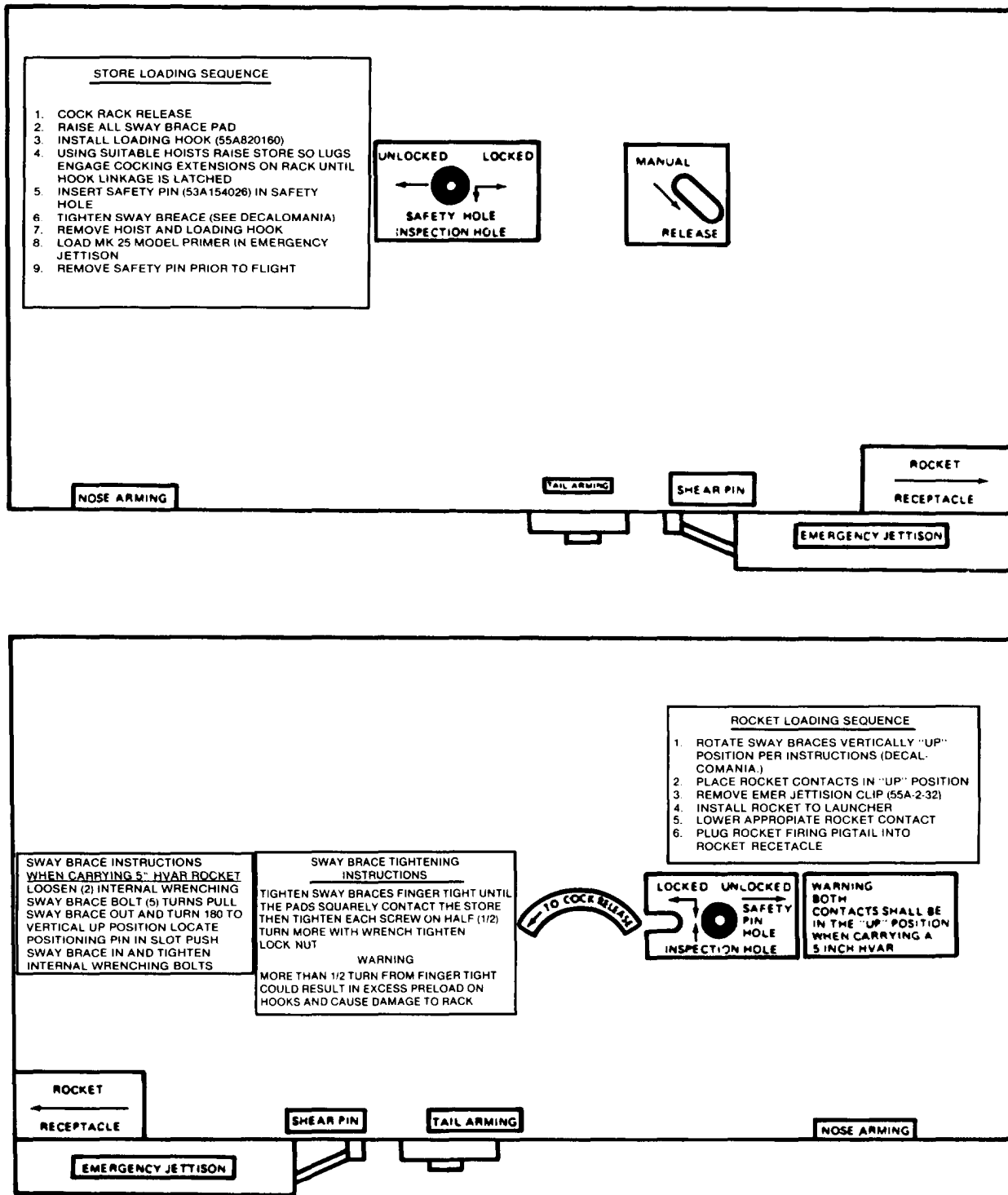


Figure 10-6. Warning Stencil for Vaneaxial Fan, OV-1 Incorporating Air Conditioning Systems.



AV010918

Figure 10-7. Aero 15 Bomb Rack Markings, OV-1.

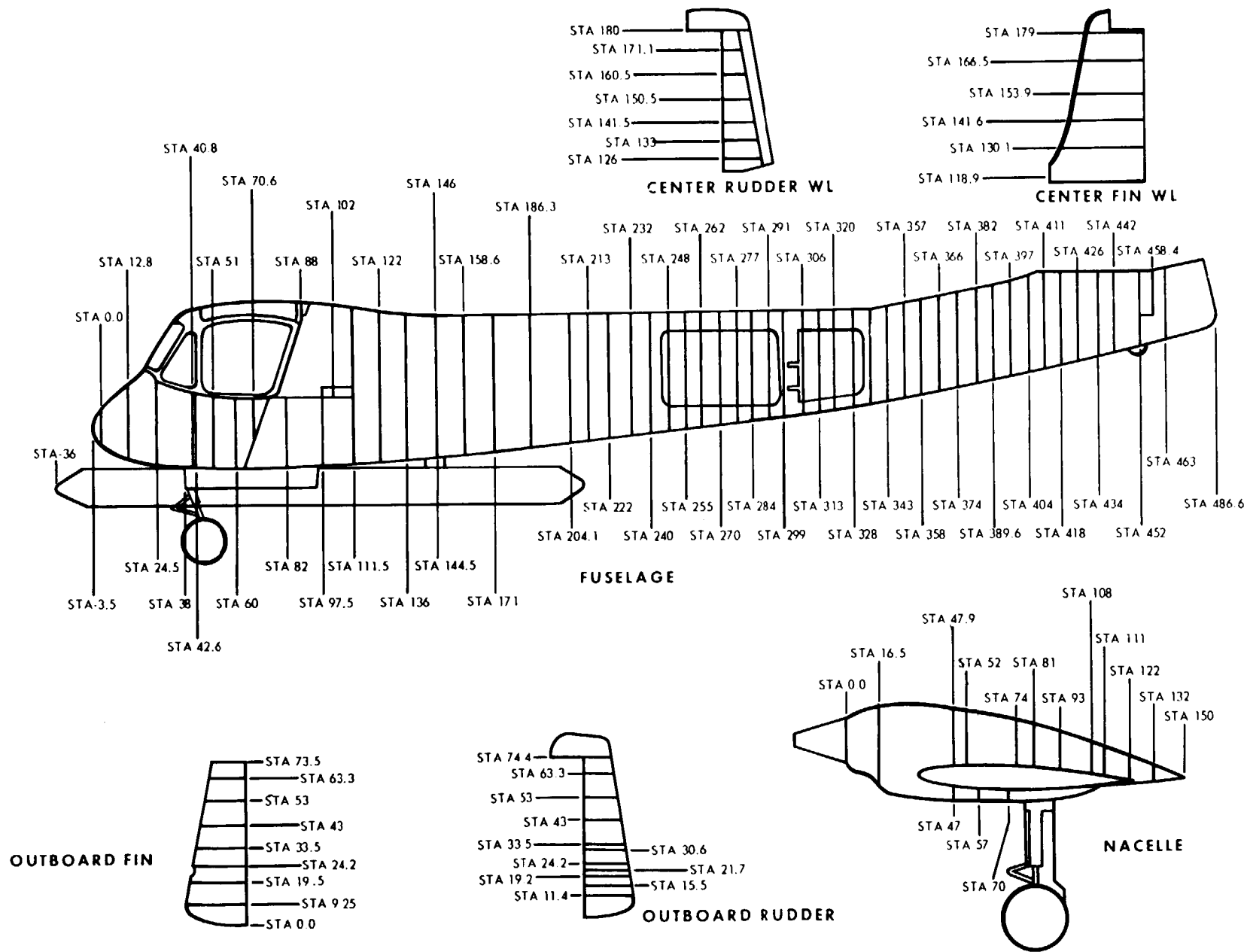


Figure 10-8. Station Diagram, OV-1 (Sheet 1 of 3).

NOTE:
 MINIMUM AREA REQUIRED TO HOUSE AIRCRAFT:
 48 FT W X 43 FT LG X 13 FT H

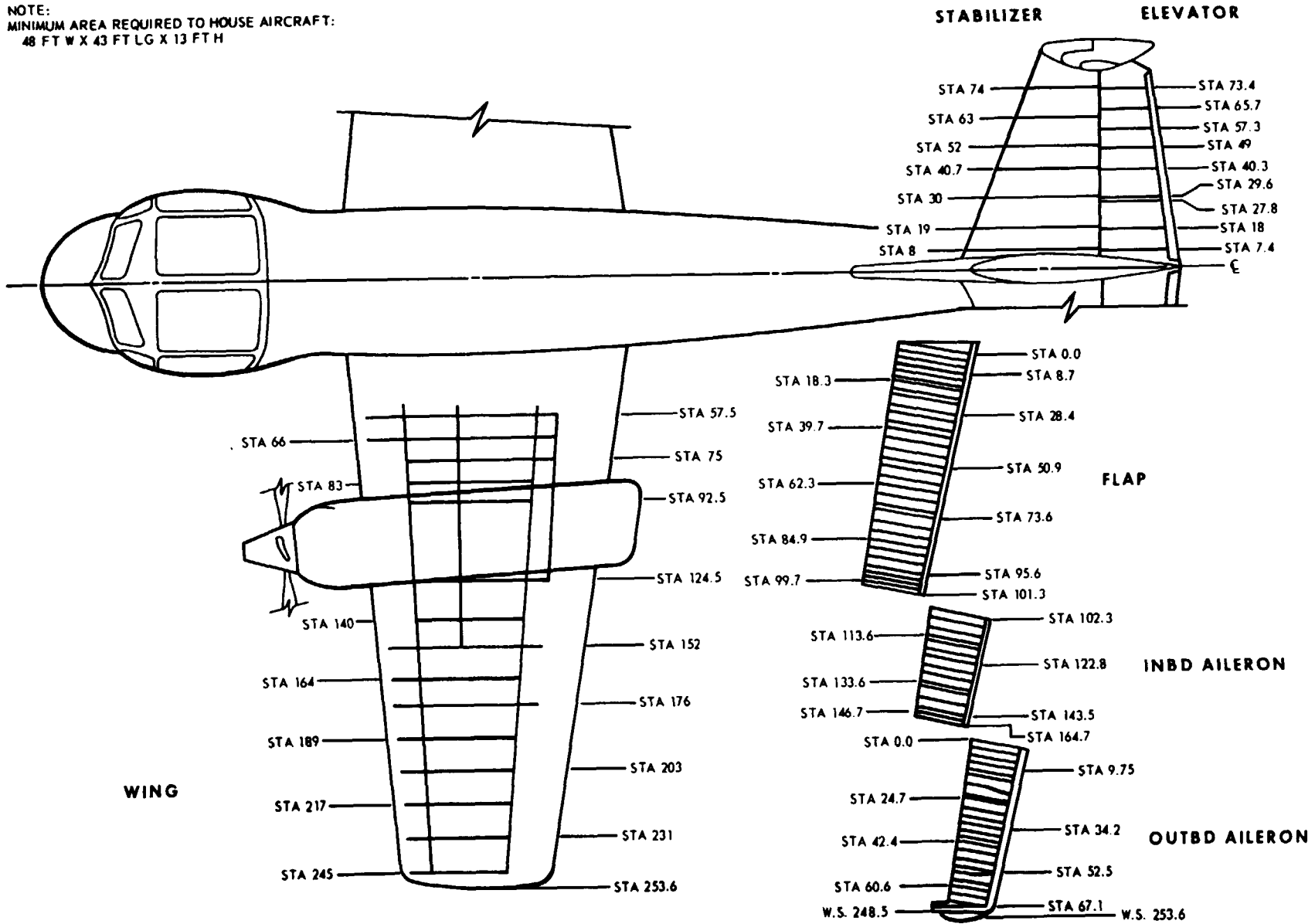


Figure 10-8. Station Diagram, OV-1 (Sheet 2 of 3).

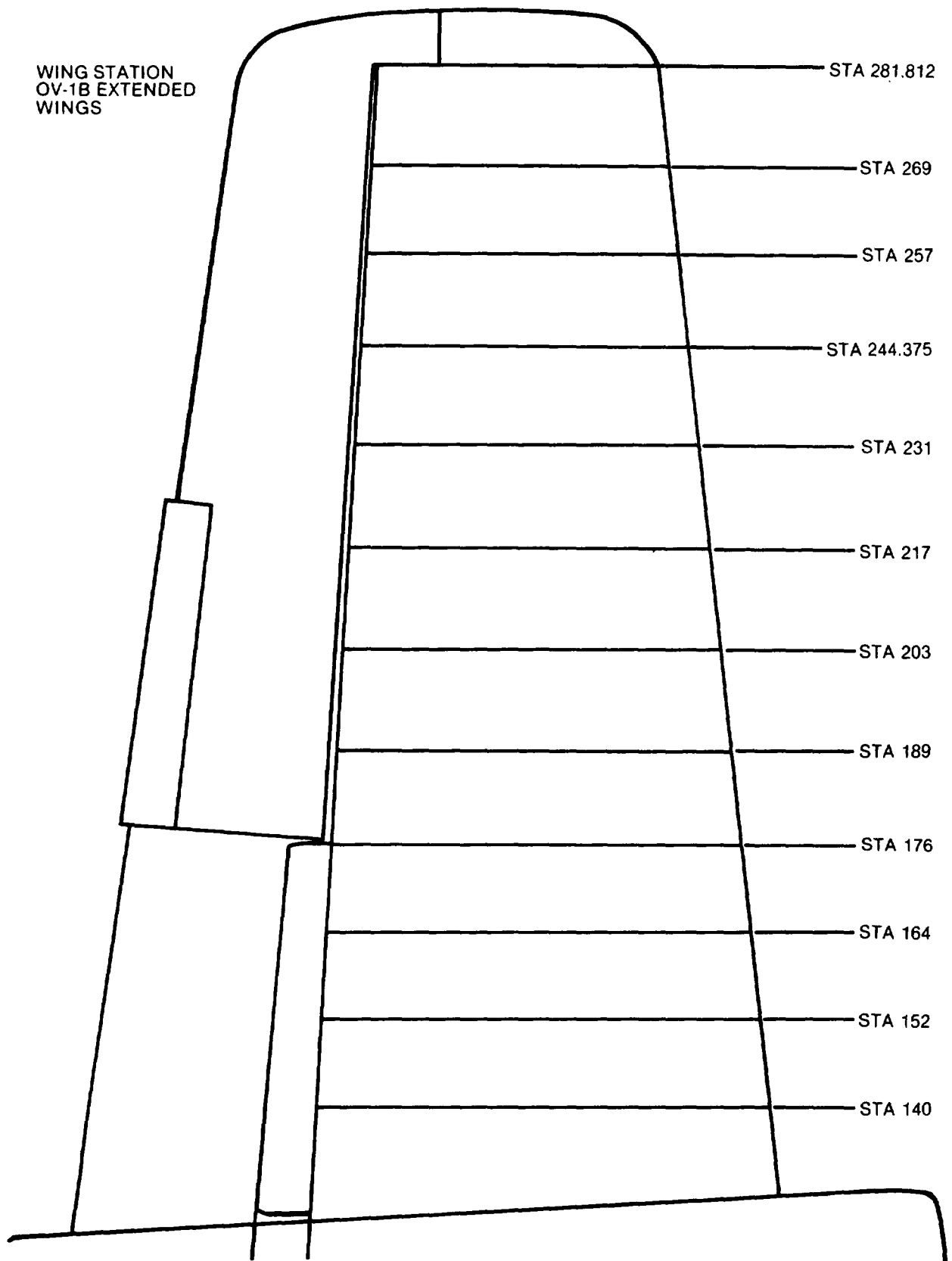
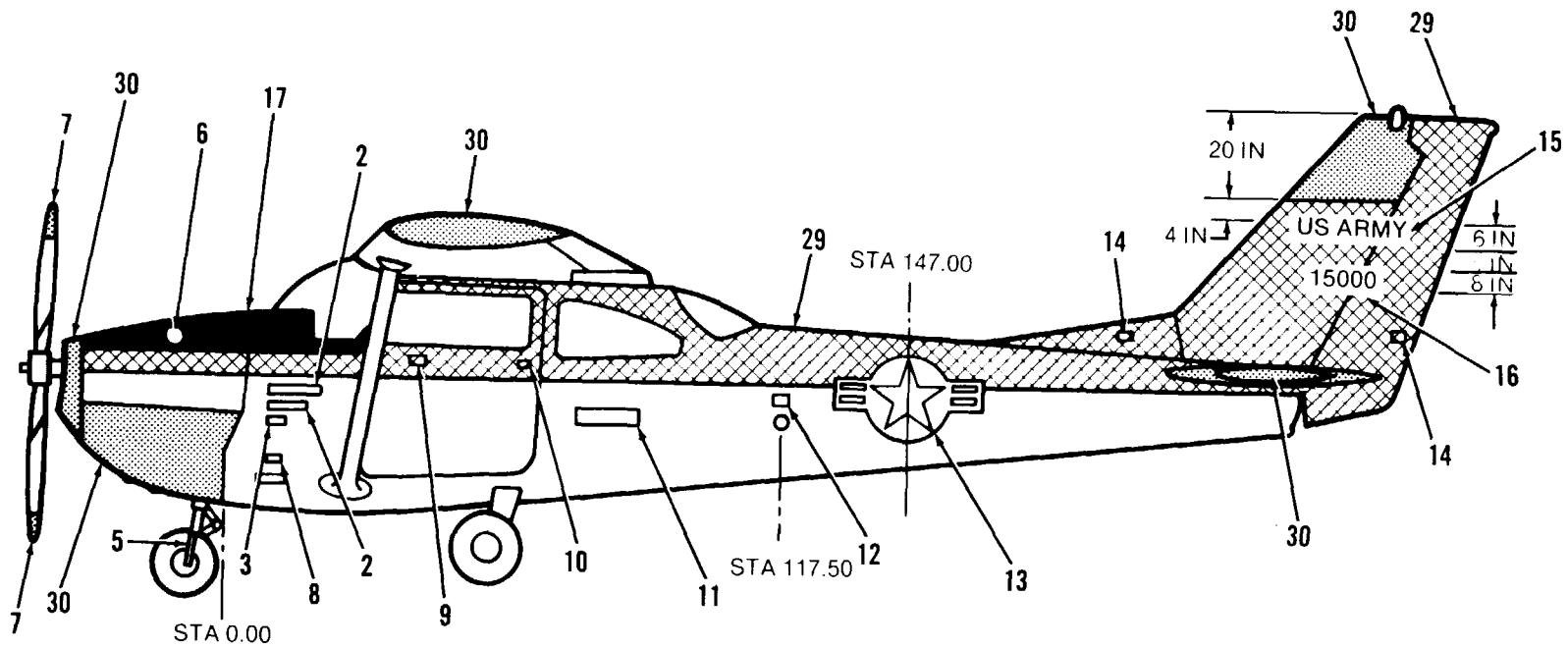


Figure 10-8. Station Diagram, OV-1 (Sheet 3 of 3)

Section IV. T-41 ILLUSTRATIONS



LEFT SIDE VIEW

Figure 10-9. Exterior Markings, T-41B (Sheet 1 of 7).

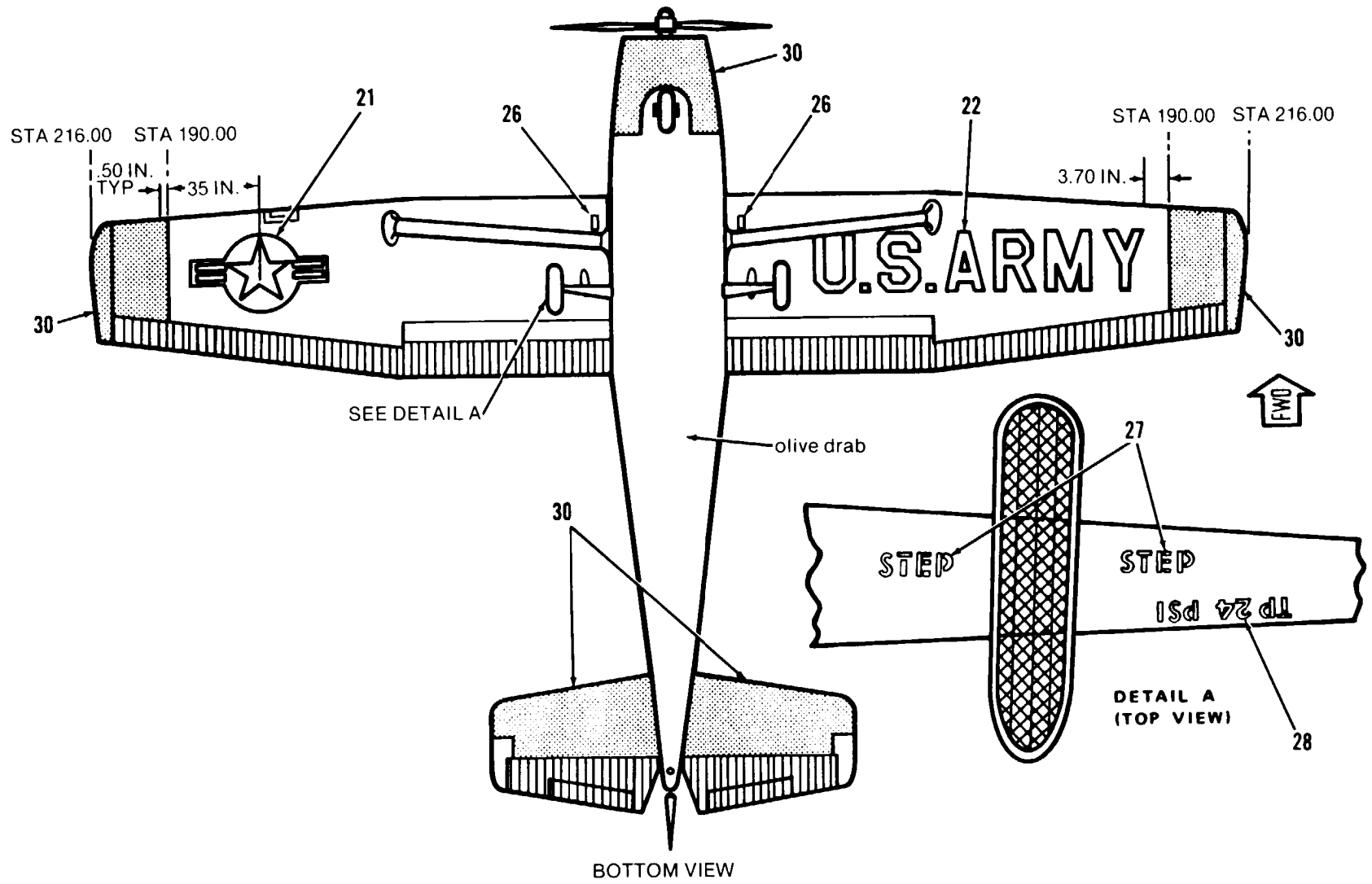


Figure 10-9. Exterior Markings, T-41B (Sheet 2 of 7).

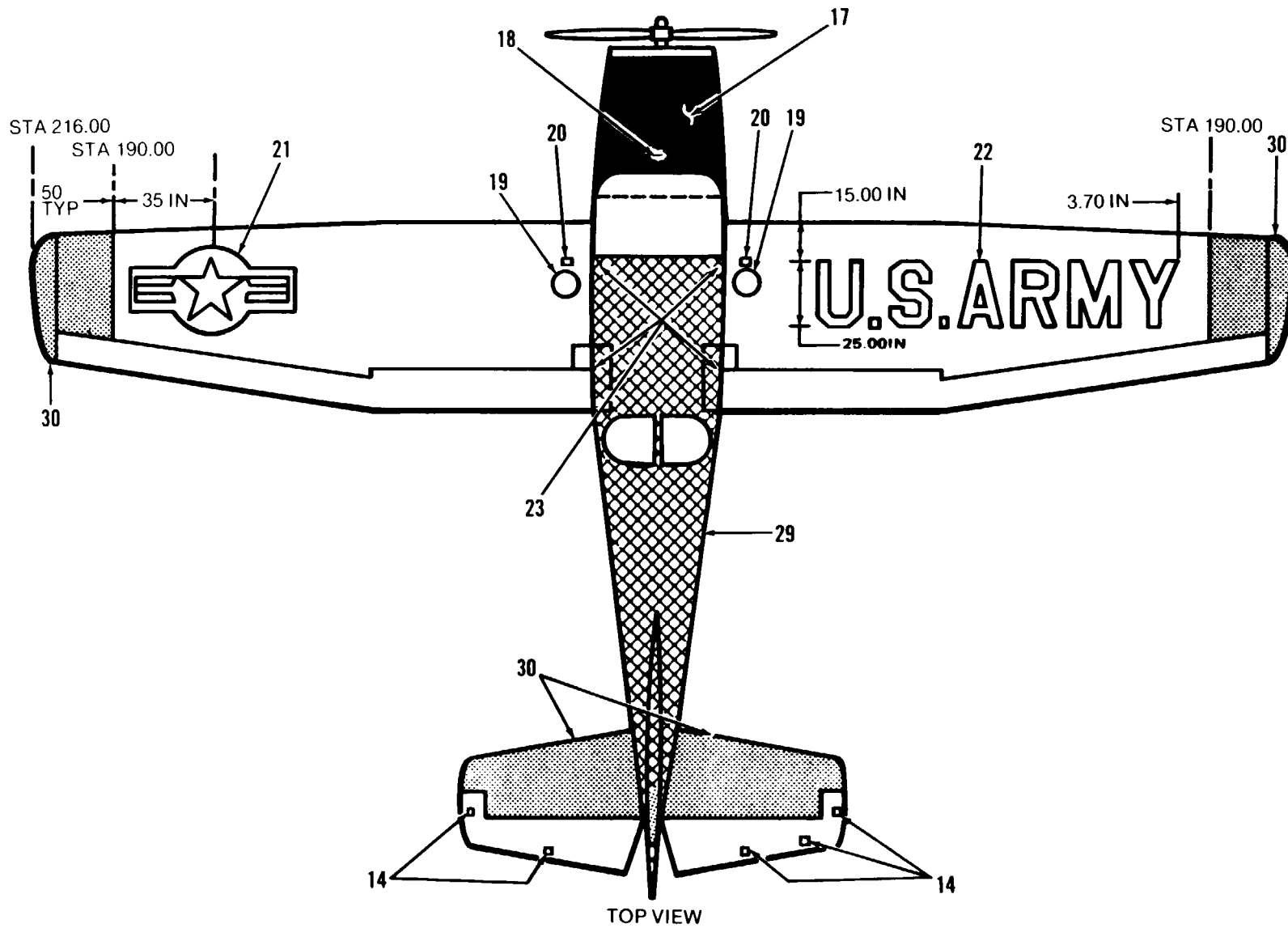
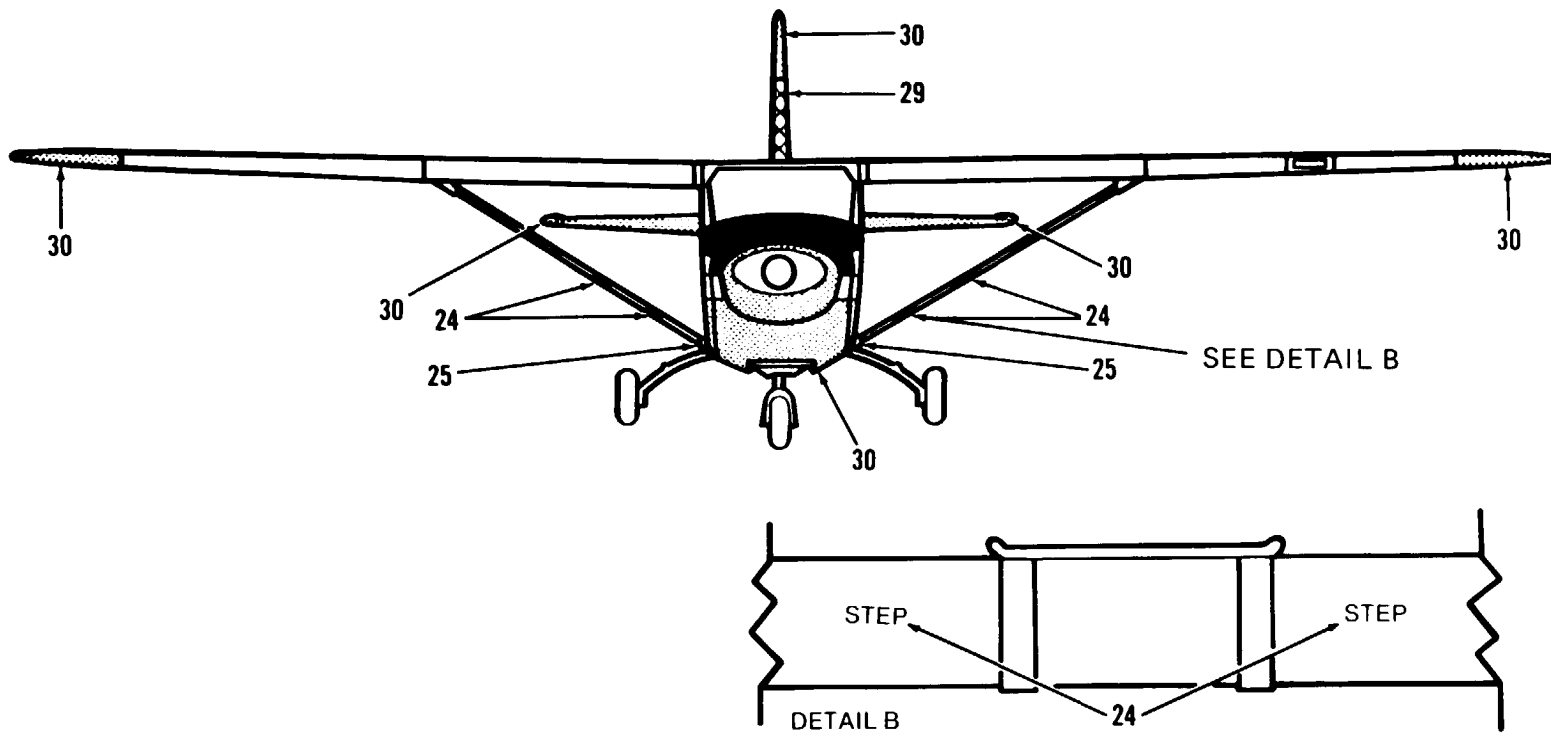


Figure 10-9. Exterior Markings. T-41B (Sheet 3 of 7).



FRONT VIEW

Figure 10-9. Exterior Markings. T-41B (Sheet 4 of 7).

CODE NO.	DIRECTIONS	WORDING
1	Left side of fuselage. On OD paint aft of top engine cowl. 1-in. yellow letters.	U.S. ARMY T-41B U.S.A. SERIAL NO. (Insert Serial No.)
2	Left side of fuselage, below model designator. 1/2-in. yellow letters.	Service this aircraft with MIL-G-5572 Grade 115/145 aviation fuel. If not available use Grade 100/130
3	Left side of fuselage, below fuel specification. 1/4-in. yellow letters. Paint Code. * * Paint Contractor will insert their initials after NCAD.	NCAD**WP#-P#-L#-DATE WP-MIL-C-8514 P- MIL-P-8585 L-TT-L-32
4	DELETED	
5	Nose wheel tire pressure on side of nose gear fork. Place stencil on side where valve stem is installed. 1/2-in. letters.	TP 26 PSI
6	Top of left engine cowling at oil filler access door. 1-in. below or outbd of access door. 1/2-in. yellow letters.	OIL MHS-24A SAE 50 ABOVE + 40° F SAE 40 BELOW + 40° F TB55-9150-200-24
7	Light application of lusterless black shade 37038 on back side of blades only. Paint 4-in. yellow tip on fwd side of tips only. For high visibility paint scheme of propellers and spinners, see Chapter 6.	
8	Both sides fuselage, 2-in. above step. 1/2-in. yellow letters. Paint step with nonskid material.	STEP
9	Both sides of cabin door, centered between door glass and OD. End of first line is 2.75 in. fwd of door opening handle. 1/2-in. black letters.	FIRE EXTINGUISHER LOCATED INSIDE
10	Both sides on cabin doors, centered on door opening handle. 1/2-in. black letters.	PULL
11	Left sides of fuselage on OD. Below aft side cabin windows 1-in. letters.	BATTERY LOCATION AFT OF BAGGAGE COMPARTMENT

Figure 10-9. Exterior Markings, T-41 B (Sheet 5 of 7)


CODE NO.	DIRECTIONS	WORDING
12	Both sides of fuselage at sta 117.25, 1/2-in. yellow letters. arrow 1/2 x 1.50 in. Bottom of mow is 3.50 in. above center of static port.	<p>STATIC SOURCE</p> 
13	Both sides of fuselage. A 15-in. dia basic blue circle center vertically. Bottom of top star frame in line with OD/white seam.	(National Star Insignia)
14	Both sides of dorsal fin and rudder. Top of elevators, elevator tab and elevator tips. 1/2-in. black on white, yellow on OD.	NO PUSH
15	Both sides of centered fin and rudder. Top of letters 24-in. down from top of fin. 6-in. black letters.	U.S. ARMY
16	Both sides of fin and rudder, centered 4-in. below U.S. ARMY. 8-in. black numbers. Use last five digits of aircraft serial number.	(Radio Call Numbers)
17	Antiglare area. Top of engine cowling. Lusterless black from fwd of windshield to speed ring cowl.	
18	Top of cowl fwd of windshield, between handgrip and windshield. Top of letters facing aft. 1/2-in. yellow letters.	HANDGRIP
19	Delete	
20	Top of each wing fwd of fuel filler caps. 1/2-in yellow letters facing aft.	<p>FUEL MIL G-5572 115/145</p>
21	Top of left wing, bottom of right wing. A 25-in. dia basic blue circle. Centered 35-in. inboard of wing station 190.0. Point of star facing fwd.	(National Star Insignia)
22	Top of right wing, bottom of left wing. 25-in. yellow letters. 3.75 in. inboard of wing station 190.	U.S. ARMY

Figure 10-9. Exterior Markings, T-41B (Sheet 6 of 7)

CODE NO.	DIRECTIONS	WORDING
23	Top of fuselage at 4 lifting eyes. 1/2-in. black letters facing outboard. Locate stencil on the inboard side of the lifting eye.	LIFT
24	On leading edge of each wing strut, above and below step. 1/2-in. yellow letters.	STEP
25	On lower end of wing struts. Upper side near fuselage, 1/2-in. yellow letters. Part number facing fwd.	0523606.17 (L. H.) 0523606.18 (R. H.)
26	Underside inboard of each wing, 2-in. aft of centerline of front spar rivets, 1 1/2 in. outbd of gap fairing strip. 1/2-in. yellow letters, top of letters facing inbd.	CAUTION: DISCONNECT ELECTRICAL WIRING BEFORE REMOVING WING.
27	On top of left and right main landing gear strut on each side of step. Top of letters facing fwd. 1/2-in. yellow.	STEP
28	On top of left and right main landing gear strut, lower end near wheel. Top of letters face aft 1/2-in. letters.	TP 24 PSI
29	Gloss white, shade 17875. Applied to the rudder, vertical fin, dorsal fin, and the upper portion of the fuselage, the dividing line is centered on the crankshaft of the horizontal row of rivets immediately below the stabilizer.	
30	Fluorescent red, shade 633. Applied to the entire speed cowl; the lower engine cowling, starting at the lower side of the top cowling around to the opposite side; the upper portion of the vertical fin, both sides, from the top to a line 20-in. down from the top; the entire horizontal stabilizer; and each outer wing panel from sta 190.00 to the tip.	

Figure 10-9. Exterior Markings, T-41B (Sheet 7 of 7)

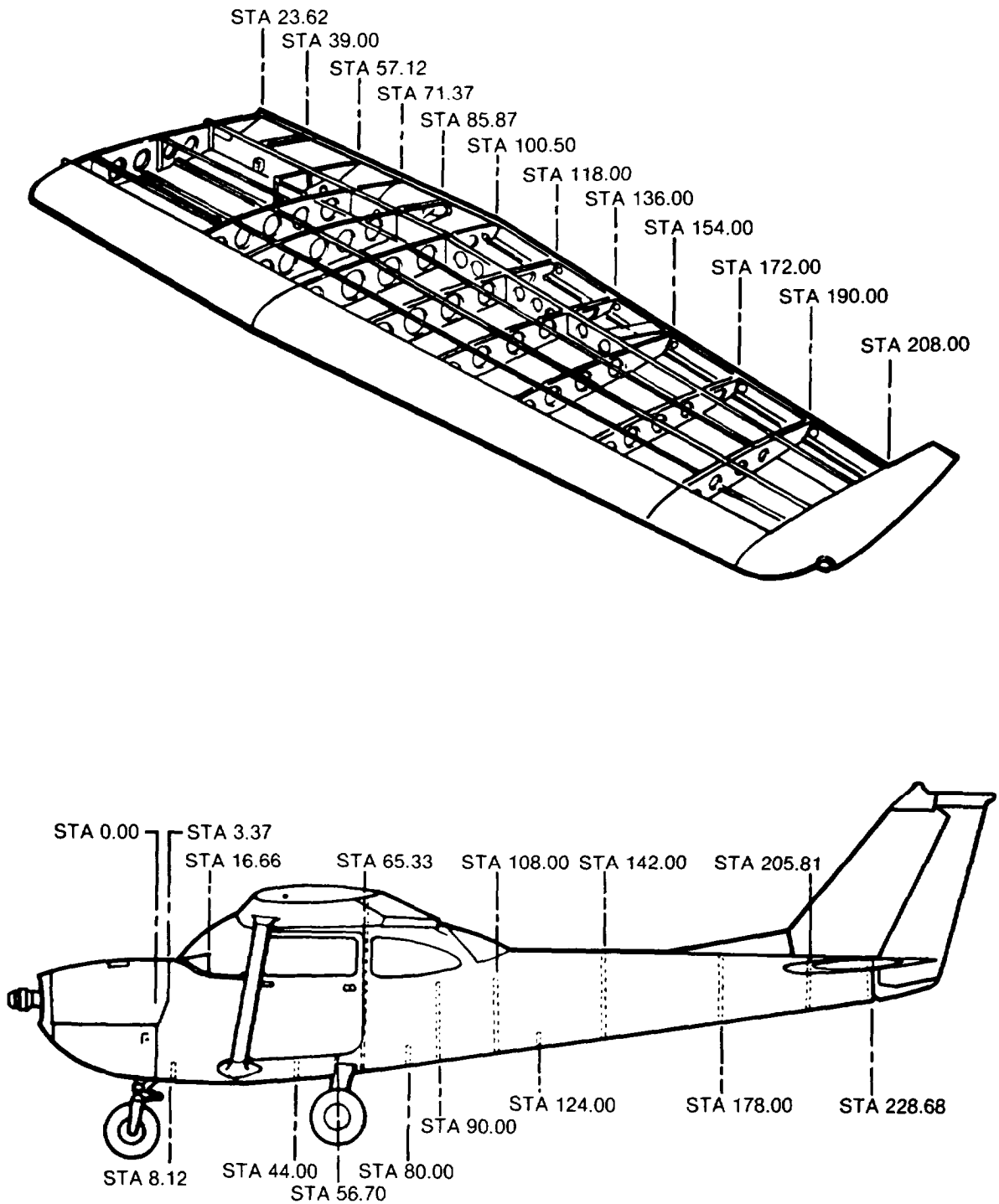
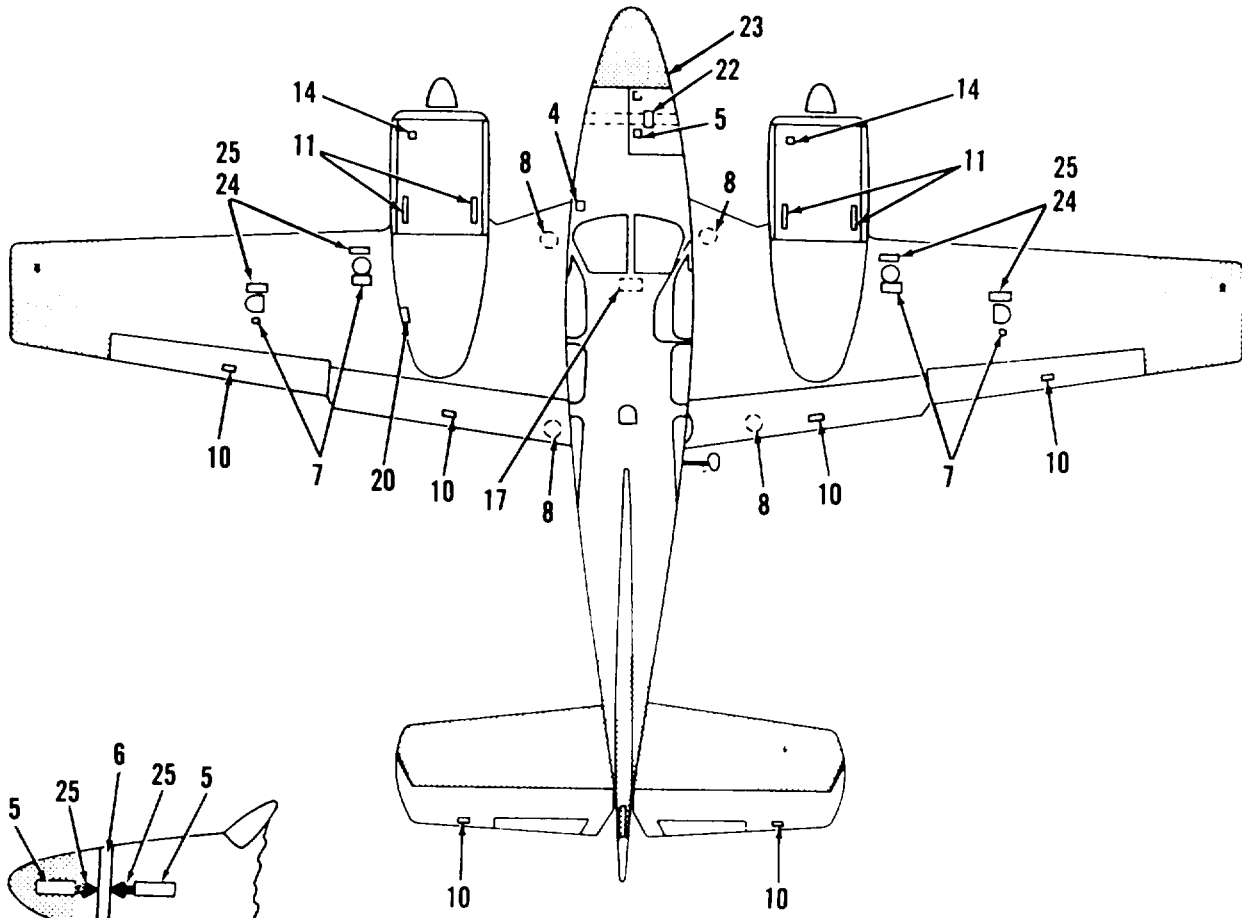


Figure 10-10. Station Diagram, T-41B.

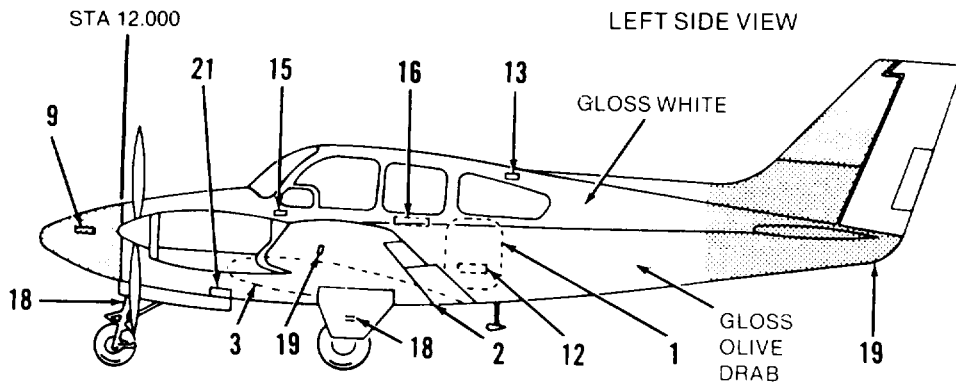
Section V. T-42 ILLUSTRATIONS



TOP VIEW

SIDE VIEW

NOTE:
HIGH VISIBILITY PAINT WILL BE
APPLIED TO SHADED AREAS FOR
TRAINING



LEFT SIDE VIEW

Figure 10-11. Exterior Markings, T-42 (Sheet 1 of 2)

COD NO. 1	DIRECTIONS	WORDING
1	Above and below rear baggage compartment door.	LEVEL POINT
2	Underside of fuselage at rear of cabin section	JACK HERE
3	Underside of each wing stud, inbd of the gauge.	JACK PAD
4	On left side of fuselage.	AIRCRAFT MODEL - U.S. ARMY T-42 SERIAL # U.S. ARMY SERIAL NO.
5	On upper right inboard wing	DANGER
6	White lettering on 3 in. red strip.	WARNING PROP
7	On upper portion of wing. 4 tanks., each individually filled.	FUEL MIL-G-5572 100/130
8	On inbd right and left upper wings.	NO STEP
9	On both sides of nose,	DO NOT
10	On main and tail wing flaps.	NO PUSH
11	Left and right of each engine cowling	MAGNETO DISCONNECT
12	Baggage load.	AFT BAGGAGE 400 LBS.
13	On left, above rear side window,	EMERGENCY RESCUE
14	On each engine cowling.	OIL MILL-2285 1
15	Left side of fuselage.	OPERATION INFORMATION
16	Right side of fuselage below window.	FIRE EXTINGUISHER
17	Center of main cabin floor.	EMERGENCY LANDING GEAR /ATTACHING PARTS/SCREW
18	Tire Pressure: *Nose wheels 50 psi *Main wheels 50 psi	*PSI
19	Underside of each wing and on tail bumper.	TIE DOWN
20	Under access plate on the lower outbd of left	24 VOLT
21	Underside at front section.	INSTR ELECTRICAL CONNECTION
22	Nose baggage loading limit.	NOSE BAGGAGE LOADING LIMIT
23	Nose baggage compartment RH fuselage section.	BATTERY INSIDE
24	Fwd of filler cap.	CAUTION DO NOT INSERT FUEL NOZZLE MORE THAN THREE INCHES INTO TANK
25	DELETE	
26	Paint anew each side of propeller warning stripe.	

Figure 10-11. Exterior Markings, T-42 (Sheet 2 of 2)

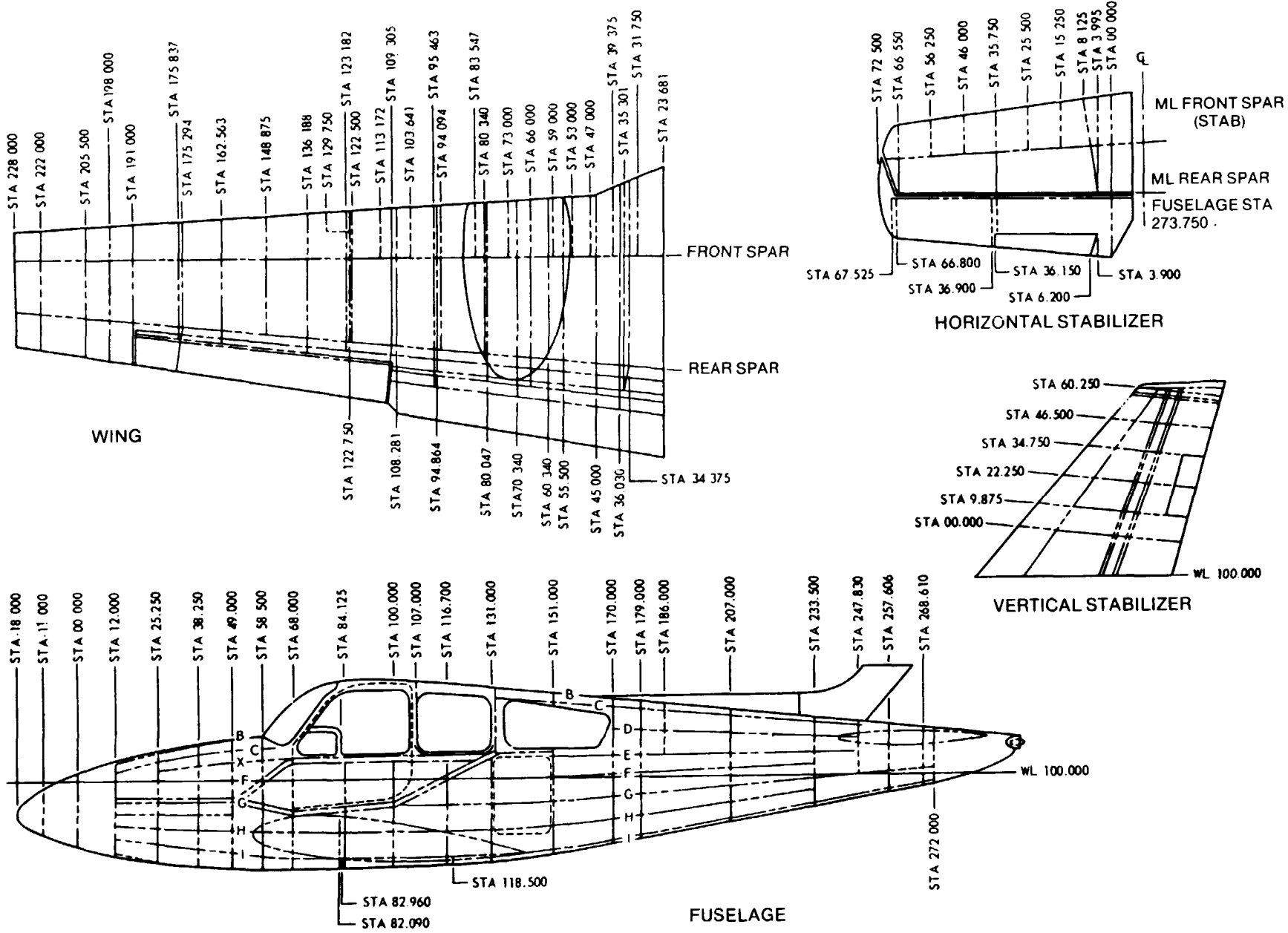


Figure 10-12. Station Diagram, T-42

Section VI. U-3 ILLUSTRATIONS

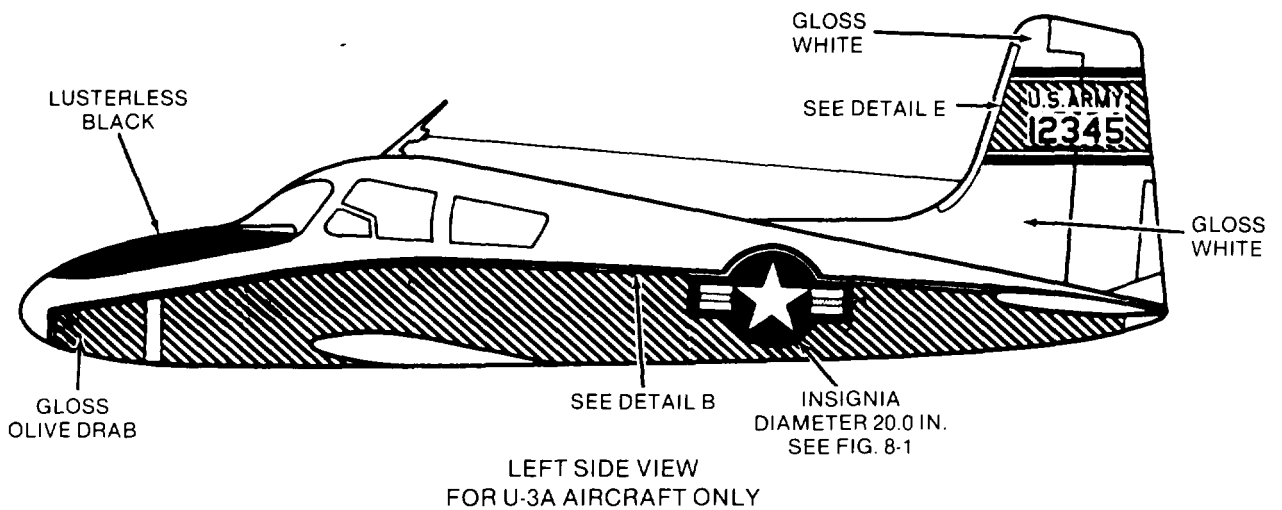
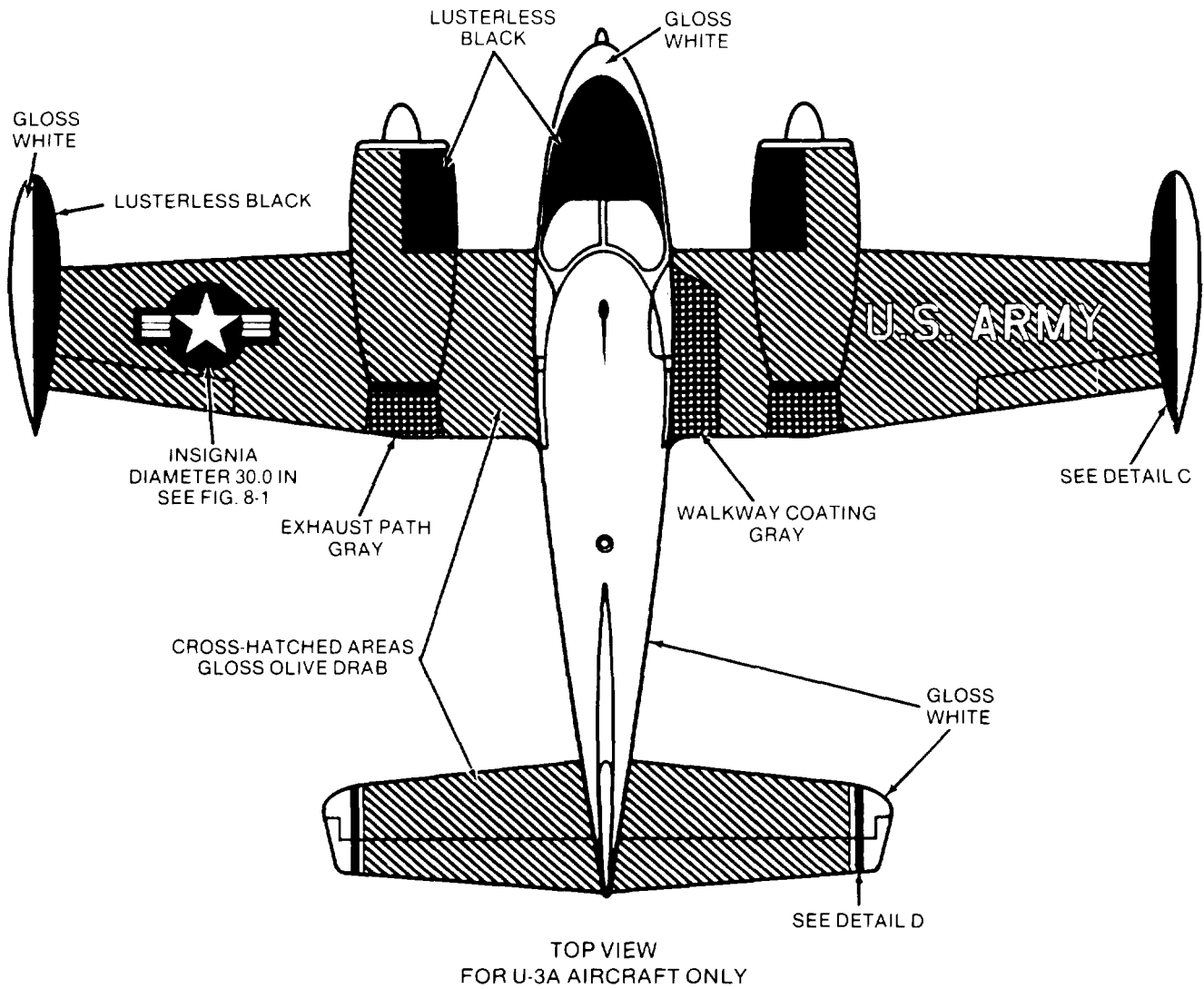
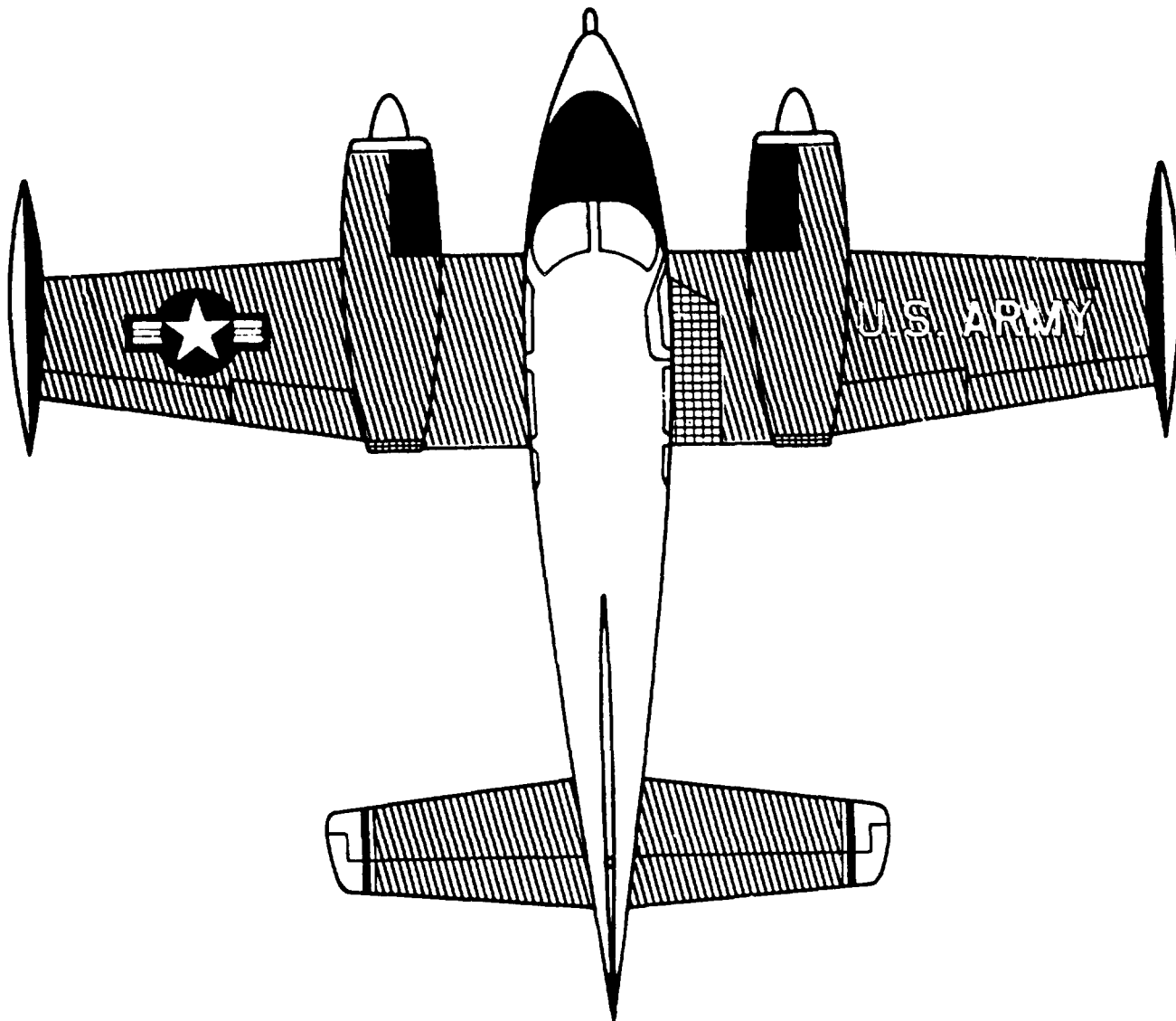


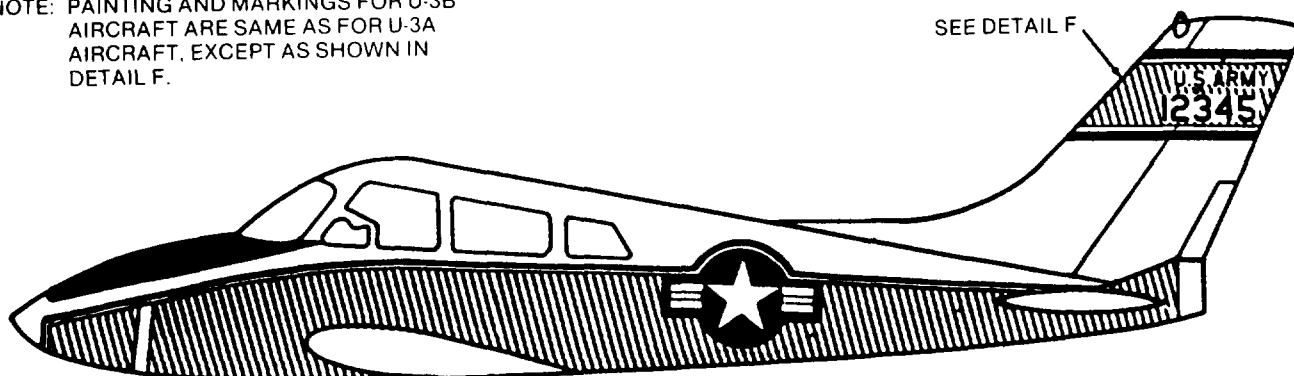
Figure 10-13. High Visibility Paint Scheme, U-3A and U-3B (Sheet 1 of 4)



TOP VIEW
FOR U-3B AIRCRAFT ONLY

NOTE: PAINTING AND MARKINGS FOR U-3B AIRCRAFT ARE SAME AS FOR U-3A AIRCRAFT, EXCEPT AS SHOWN IN DETAIL F.

SEE DETAIL F



LEFT SIDE VIEW
FOR U-3B AIRCRAFT ONLY

Figure 10-13. High Visibility Paint Scheme, U-3A and U-3B (Sheet 2 of 4)

NOTES:

1. NOTATIONS ON WHITE PORTIONS ARE IN RED;
NOTATIONS ON OLIVE DRAB PORTIONS ARE IN YELLOW
2. ENGINE NACELLE IS OLIVE DRAB WITH BLACK ANTIGLARE PANELS
3. ALL DIMENSIONS ARE IN INCHES UNLESS OTHERWISE NOTED
4. FOR HIGH VISIBILITY PAINT SCHEME FOR PROPELLER AND SPINNER. SEE CHAPTER 6

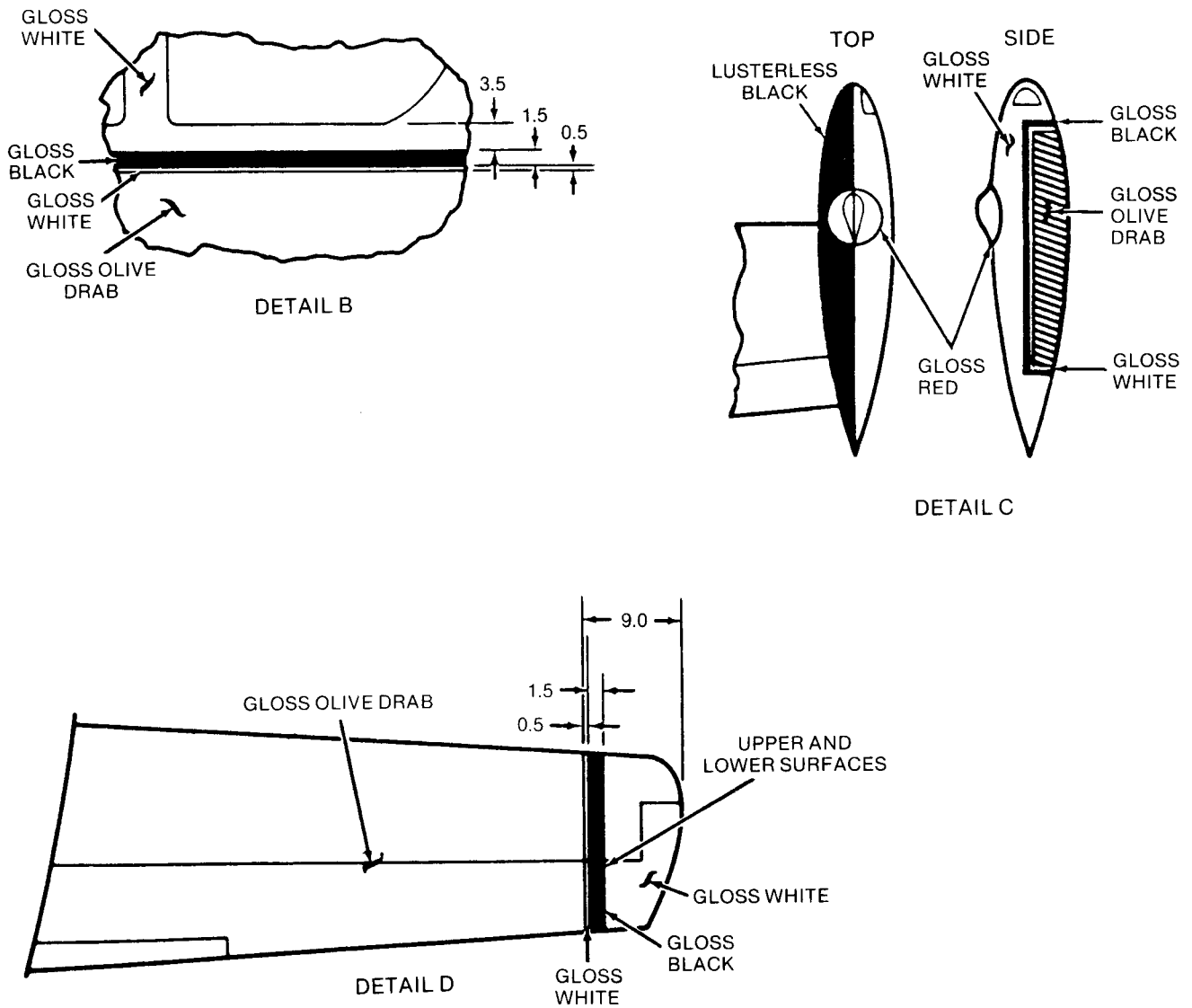


Figure 10-13. High Visibility Paint Scheme, U-3A and U-3B (Sheet 3 of 4)

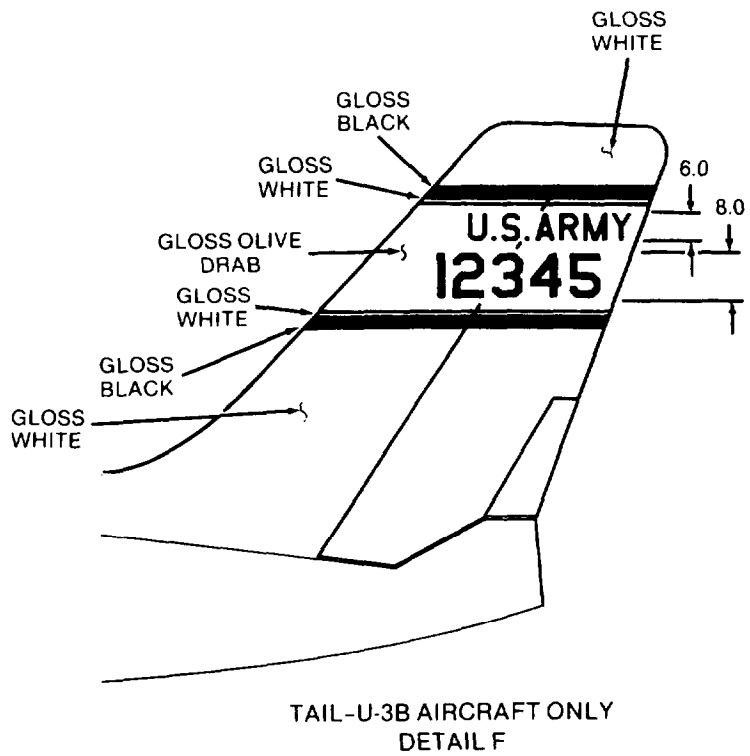
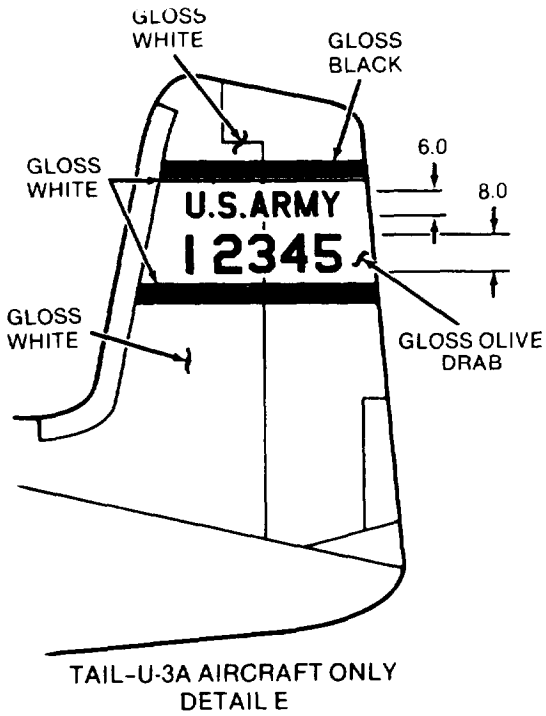


Figure 10-13. High Visibility Paint Scheme, U-3A and U-3B (Sheet 4 of 4)

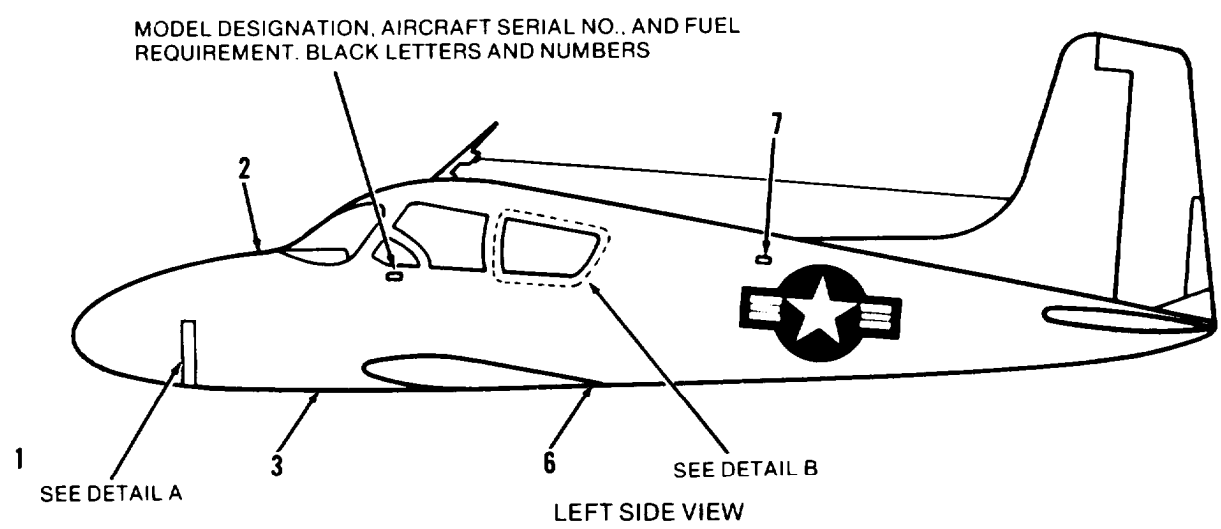
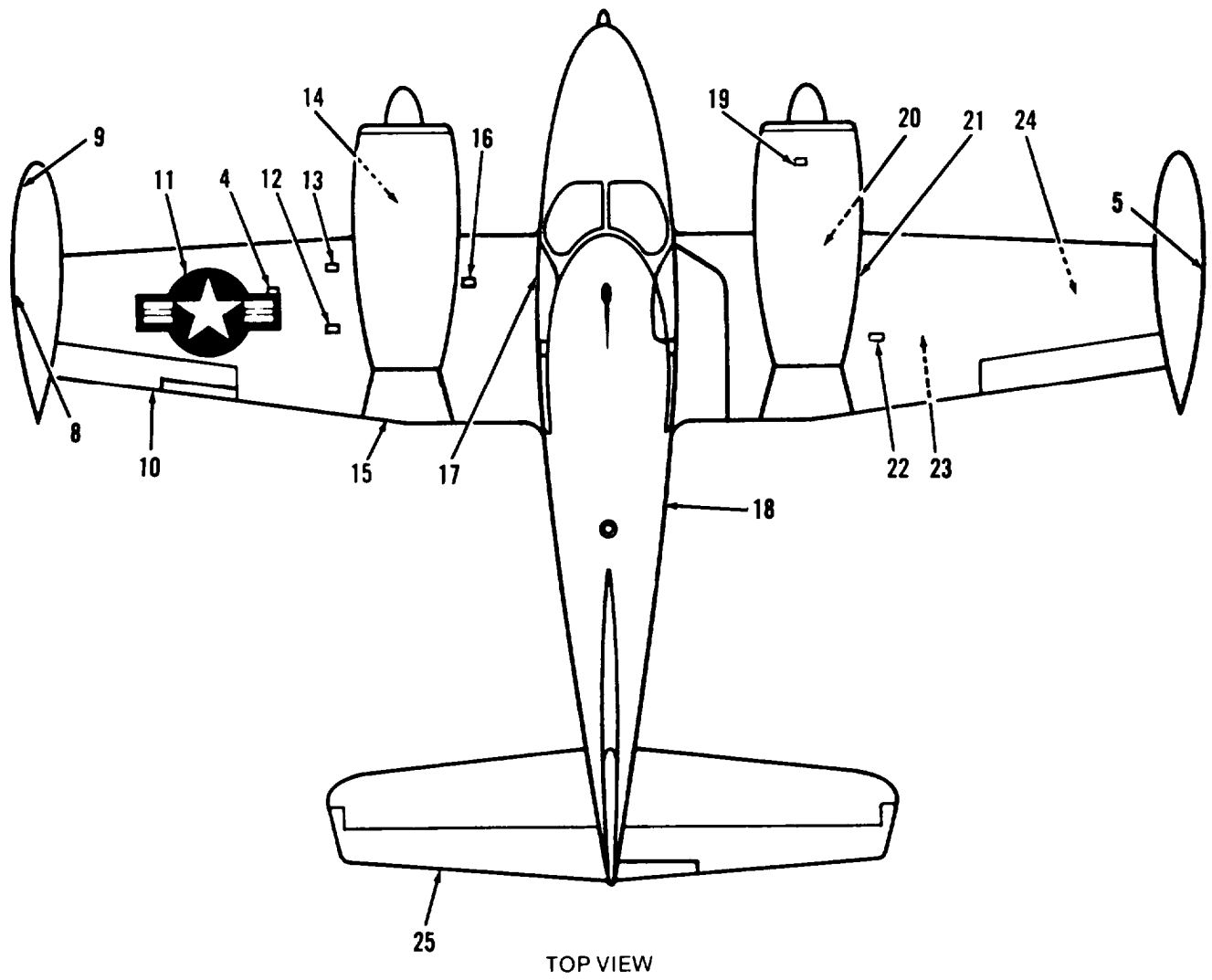


Figure 10-14. Exterior Markings, U-3A and U-3B (Sheet 1 of 5)

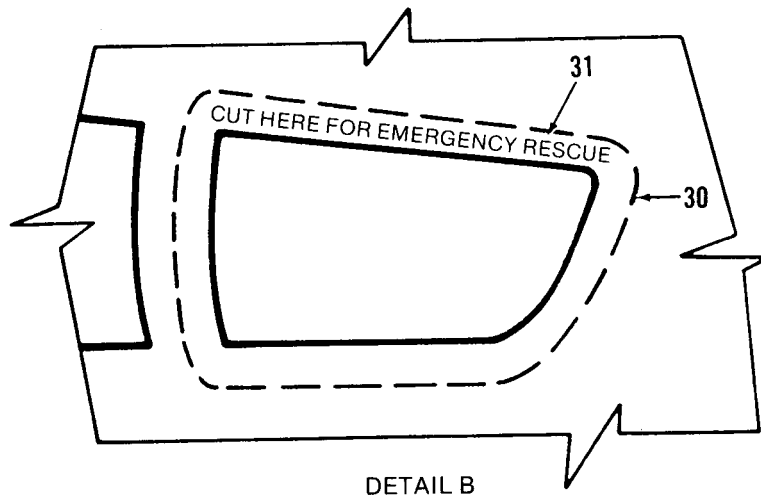
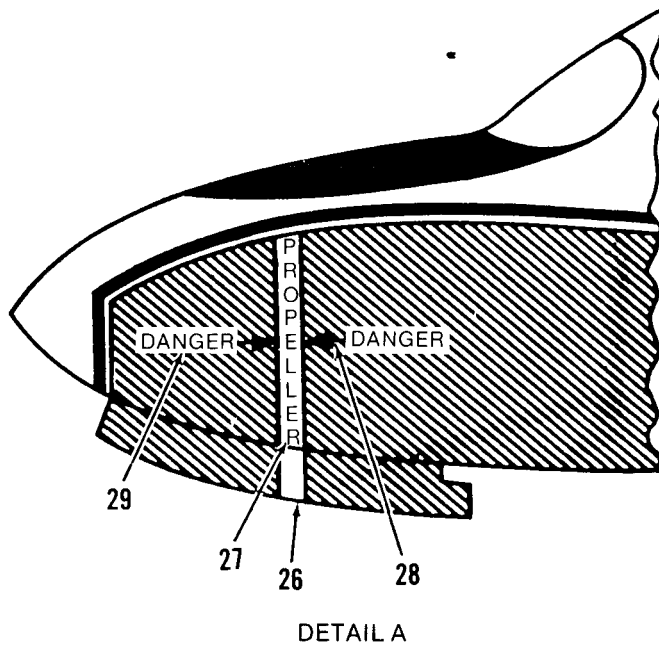


Figure 10-14. Exterior Markings, U-3A and U-3B (Sheet 2 of 5)






CODE NO.	DIRECTIONS	WORDING
1	Bottom nose of fuselage, fwd of nose gear strut. Yellow lettering.	CAUTION DO NOT TOW AIRCRAFT WITH VEHICLE. MAX. NOSE WHEEL TURN 55°
2	Right side only, 1/2-in. lettering; 1-in. long arrow points to grounding point. Yellow lettering.	GROUND HERE 
3	Aft of nose wheel gear 1/2-in. lettering; 1-in. long arrow.	JACKING POINT 
4	Right and left sides of aircraft on top of wing, 1/2-in. yellow letters centered fwd of door.	 USE 115/145 FUEL. REF TB55-9150-200-24 FOR ALTERNATE FUEL USABLE 15 GAL
5	Right and left sides of aircraft near tip tank filler cover. 1/2-in. yellow lettering to be below cover assy.	USE 115/145 FUEL. REF TB55-9150-200-24 FOR ALTERNATE FUEL
6	Right side only on crossfeed fuel drain yellow letters; 1/2-in. top line, 1/4-in. bottom line.	CROSSFEED FUEL DRAIN REMOVE FAIRING
7	Decal, left side only. Yellow 1/2-in. letters, 1-in. long arrow pointing to static port fwd of star insignia.	STATIC SOURCE 
8	Centered fwd and aft under both wing tanks. 1/2-in. yellow letters.	TANK AND SUMP DRAIN
9	Left side only, 1/2-in. yellow letters. 1-in. long arrow points to grounding point.	 GROUND HERE
10	Right and left ailerons. 1/2-in. yellow letters on olive drab or black letters on white.	NO PUSH
11	Top of left wing and bottom of right wing. See paragraph 7-3.	(National Star Insignia)
12	Bottom of left wing, outbd of nacelle. 1/2-in. yellow letters on access door. Note is 90° from other lettering.	EXT POWER POWER CAUTION 24V ONLY

Figure 10-14. Exterior Markings, U-3A and U-3B (Sheet 3 of 5)



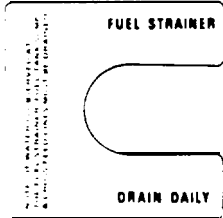

CODE NO.	DIRECTIONS	WORDING
13	Top of left wing battery access door. 3/4-in. yellow letters.	BATTERY
14	Flange, two points on nacelle,	
15	Bottom of both wings, aft of engines. Arrows, points, and letters are yellow. 1/2-in. lettering, 1-in. long arrow.	JACKING POINT 
16	Top of wing, inboard aft of nacelle. 1/2-in. yellow letters.	NO STEP
17	Left side of fuselage, below pilot window. 1-in. yellow letters.	U.S. ARMY U-3A U.S.A. SERIAL NO. (Insert serial number)
18	Right side door assembly, aft of wing. 1/2-in. yellow letters.	OXY FILLER
19	Left and right side door assembly atop nacelle. 1/2-in. yellow letters.	OIL CAPACITY 12 QTS
20	Bottom of nacelle, two places. Decal.	
21	Top of right and left wings. Outboard of nacelle. 1/2-in. yellow letters and 1-in. long arrow pointing to grounding point.	GROUND HERE 
22	Top of wings, outboard aft of nacelles. 1/2-in. yellow letters.	NO STEP
23	Under each wing, auxiliary fuel tank. 1/2-in. yellow letters.	AUX FUEL DRAIN
24	Bottom of both wings, outboard of nacelles. 1/2-in. yellow letters.	MOORING
25	Right and left side, both elevators. 1/2-in. yellow letters on olive drab or black letters on white.	NO PUSH

Figure 10-14. Exterior Markings, U-3A and U-36 (Sheet 4 of 5)

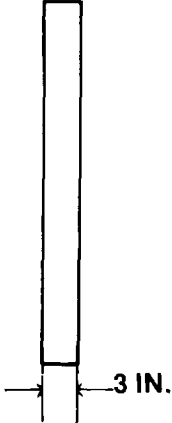
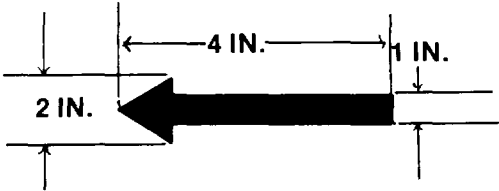
CODE NO.	DIRECTIONS	WORDING
26	<p>A 3-in. red band around fuselage. The center of the band to be centered on the travel of the propeller tip.</p> <p>On CONUS aircraft, the red band will go from the underside of the 1/2-in. white stripe under the aircraft to the underside of the 1/2-in. white stripe on the opposite side.</p>	
27	<p>2-in. white letters, proportionally spaced on the red band so the word will extend on the side of fuselage only. Do not extend onto the underside of fuselage or nose landing gear door.</p>	<p>P R O P E L L E R</p>
28	<p>Left and right side of fuselage on fwd and aft side of 3-in. red propeller warning stripe. Arrows to be placed centrally on fuselage. Tip of arrow pointing towards red band. Width of arrow shaft is 1-in, Width of arrow head is 2-in. and length of arrow is 4-in. Arrow will be red on OD aircraft.</p>	
29	<p>Left and right side of fuselage, adjacent to 4-in. arrow. 2-in. yellow letters on OD. (See Detail A).</p>	<p>DANGER</p>
30	<p>Left and right side of fuselage around rear window broken red band 1" wide denoting cut line for emergency rescue. (See Detail B).</p>	
31	<p>Left and right side of fuselage within cut-out area. 1" black letters. (See Detail B).</p>	<p>CUT HERE FOR EMERGENCY RESCUE</p>

Figure 10-14. Exterior Markings, U-3A and U-3B (Sheet 5 of 5)

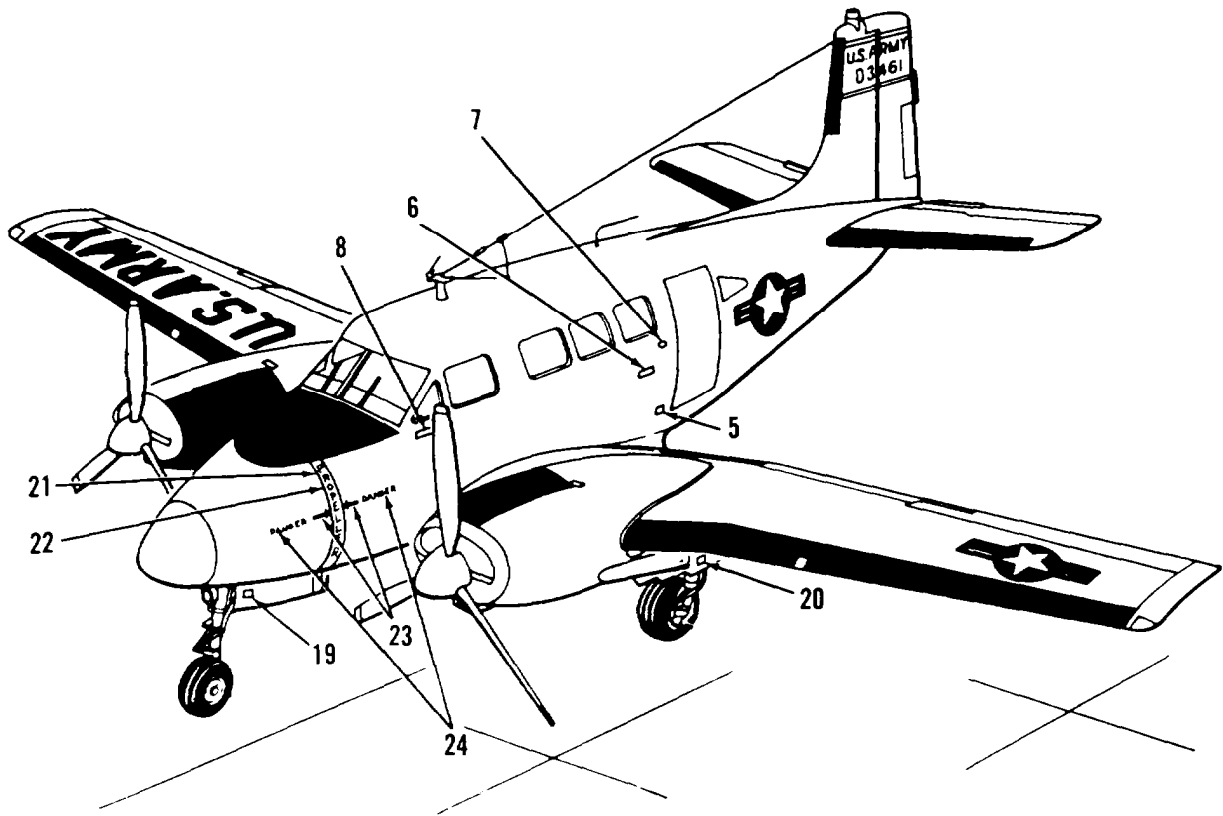
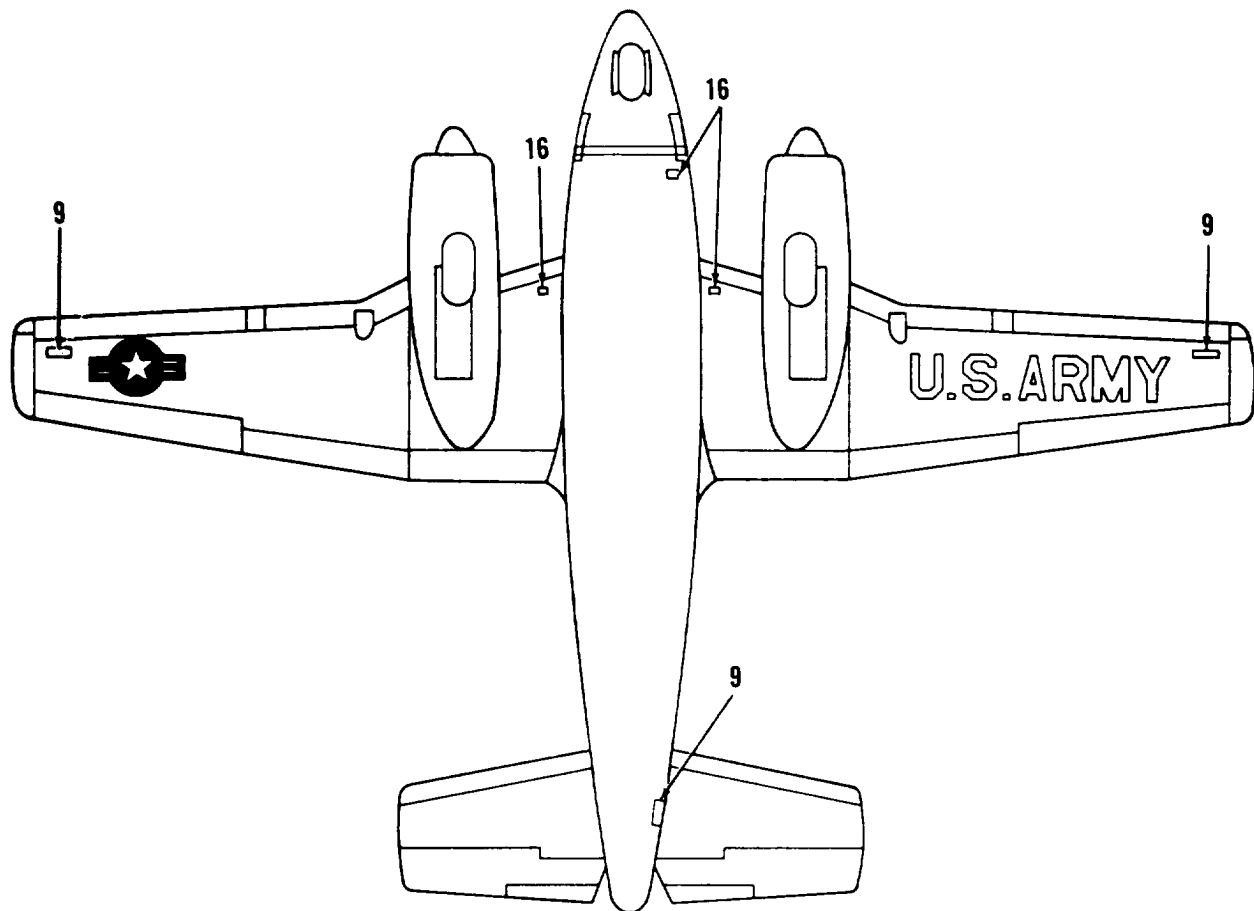
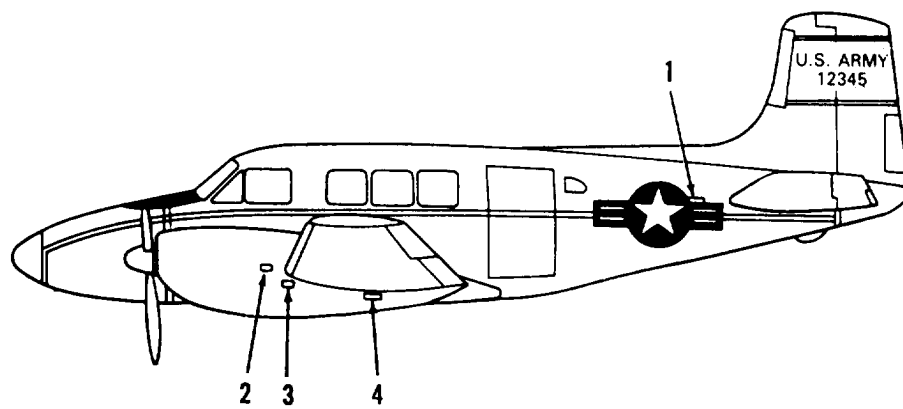


Figure 10-16. Exterior Markings, U-8F (Sheet 1 of 11)

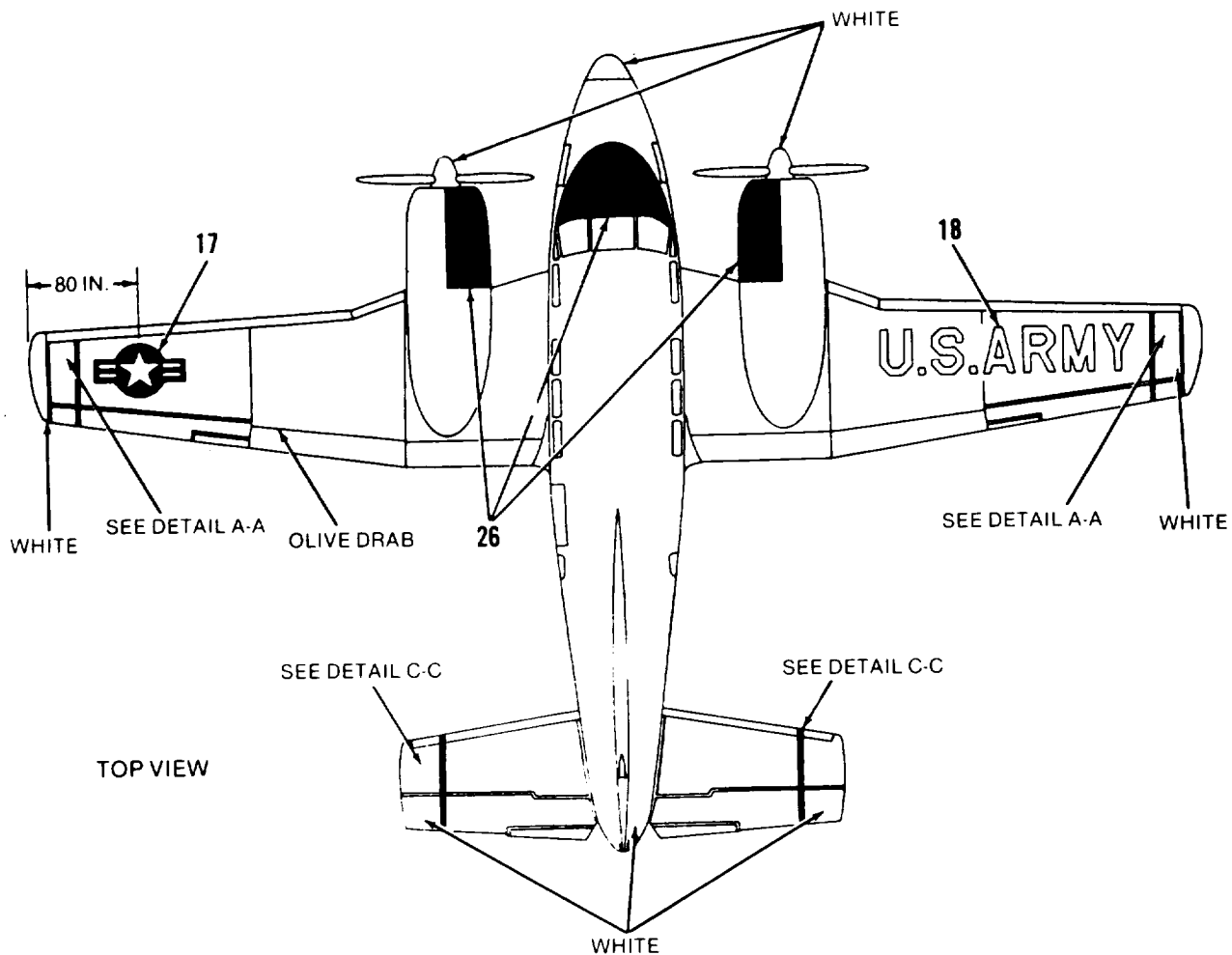


BOTTOM VIEW

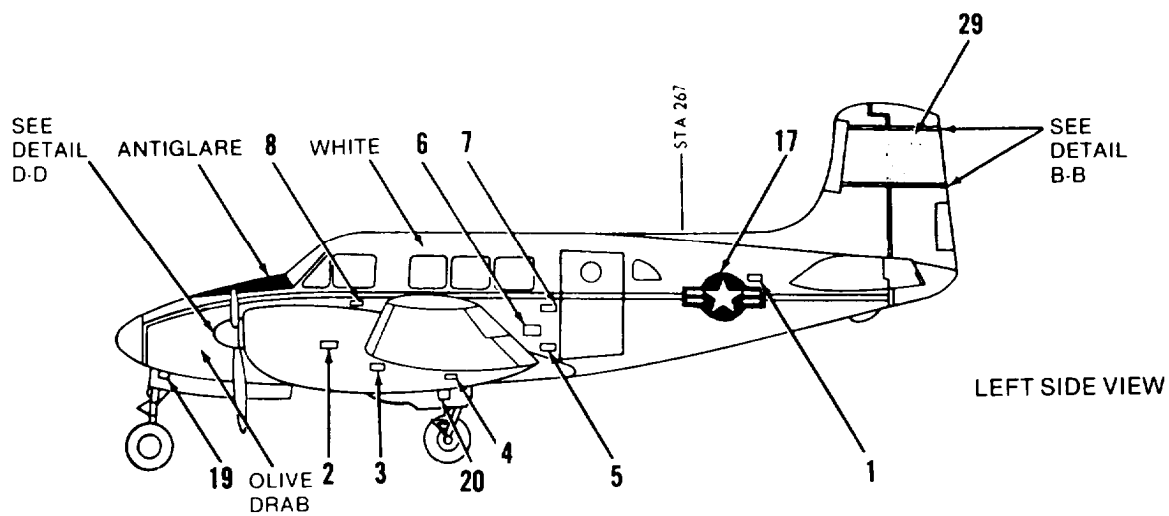


LEFT SIDE VIEW

Figure 10-16. Exterior Markings, U-8F (Sheet 2 of 11)

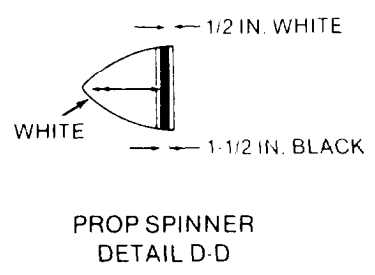
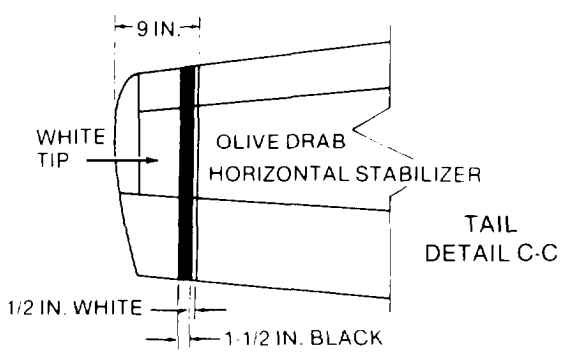
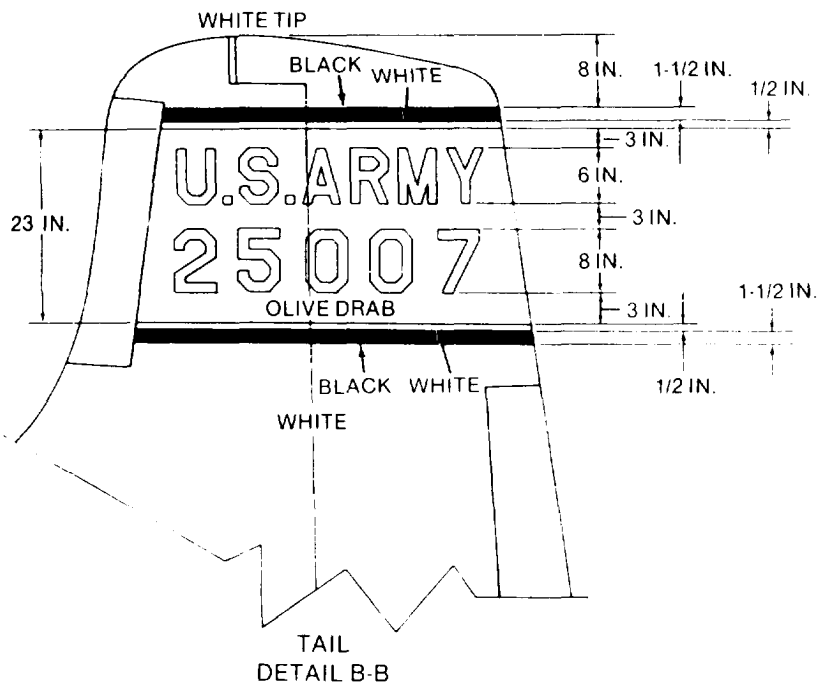
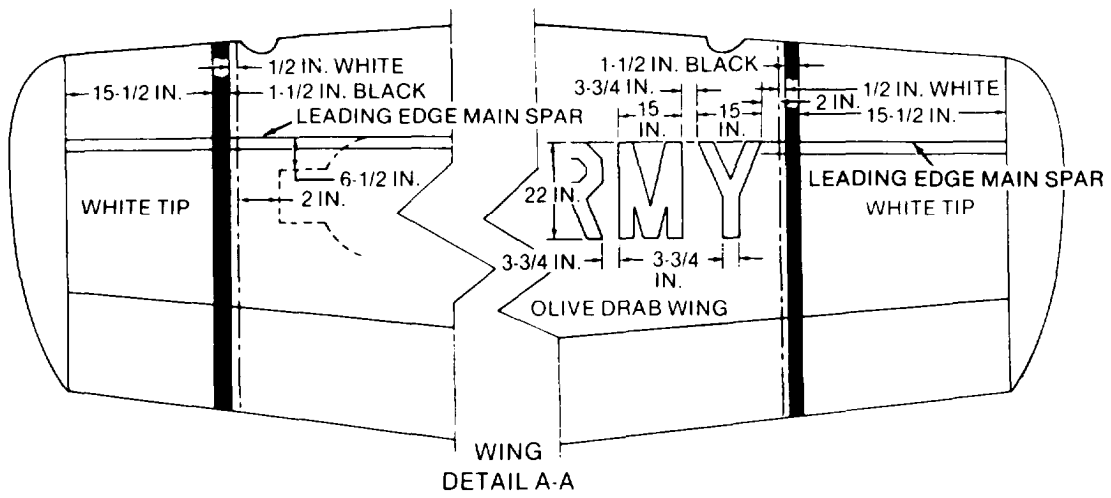


TOP VIEW



LEFT SIDE VIEW

Figure 10-16. Exterior Markings, U-8F (Sheet 3 of 11)



PROPELLERS AND SPINNER WILL BE PAINTED PER CHAPTER 6

Figure 10-16. Exterior Markings, U-8F (Sheet 4 of 11)

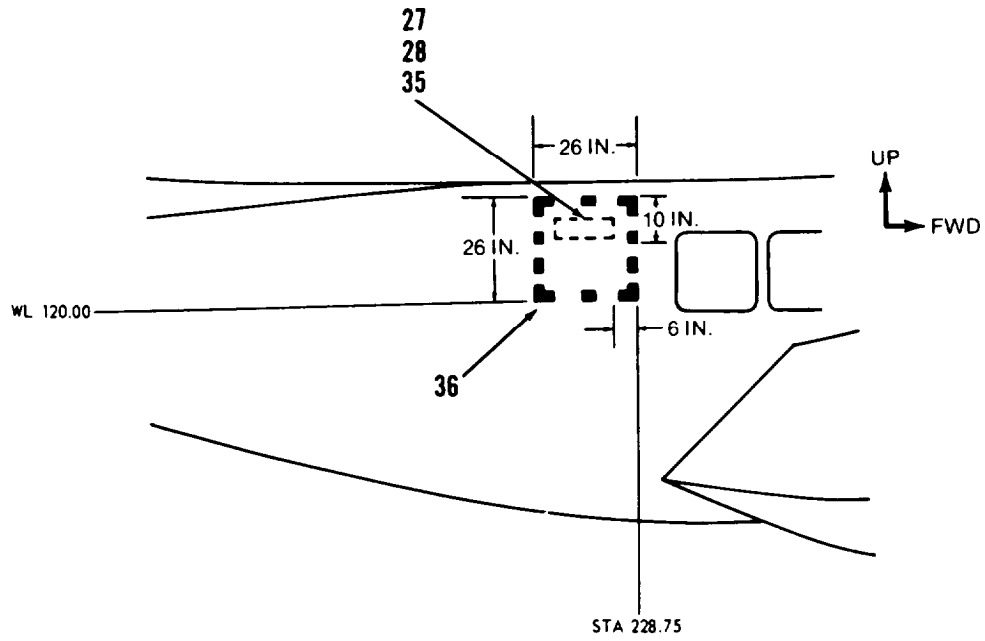


Figure 10-16. Exterior Markings, U-8F (Sheet 5 of 11)

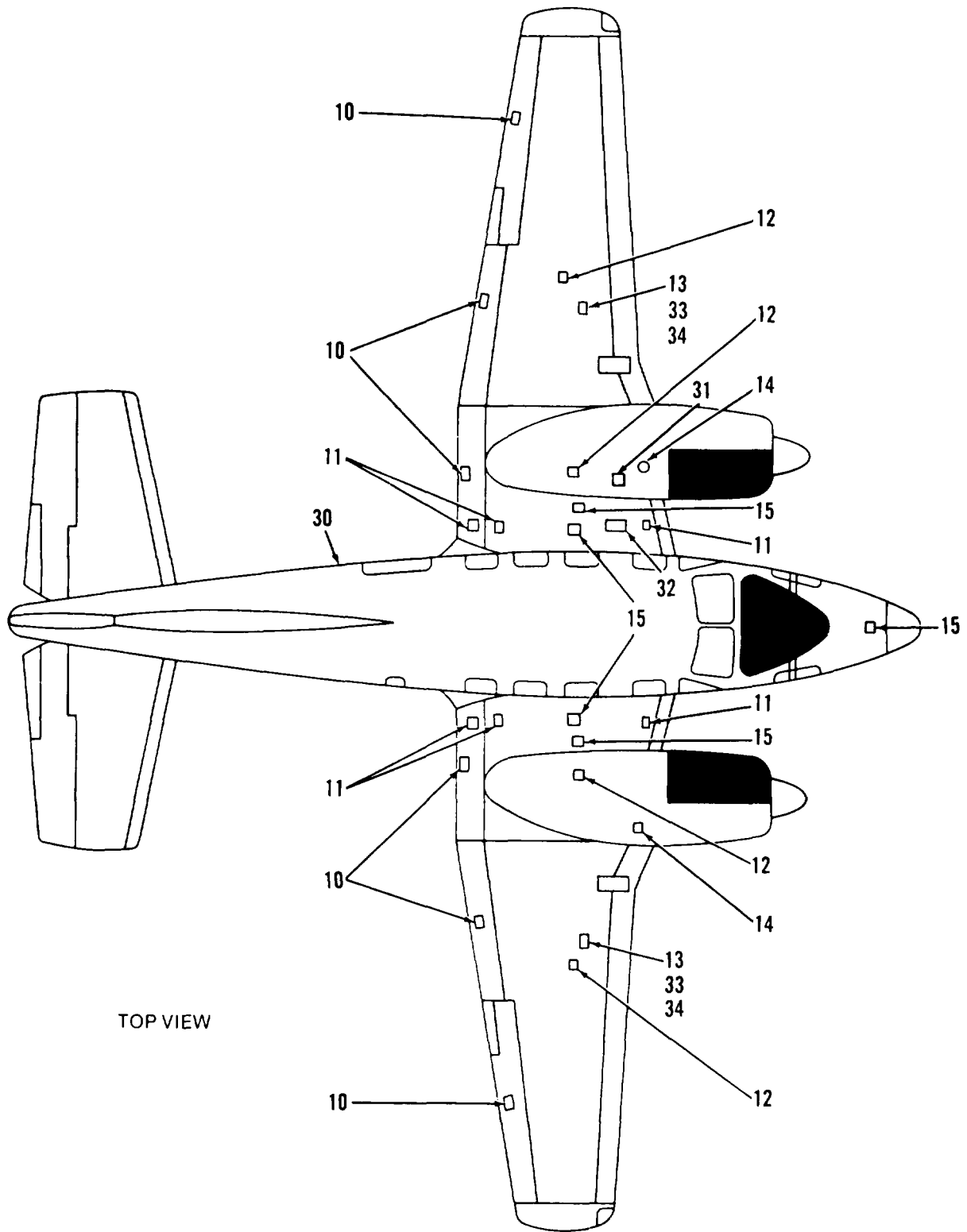


Figure 10-16. Exterior Markings, U-8F (Sheet 6 of 11)

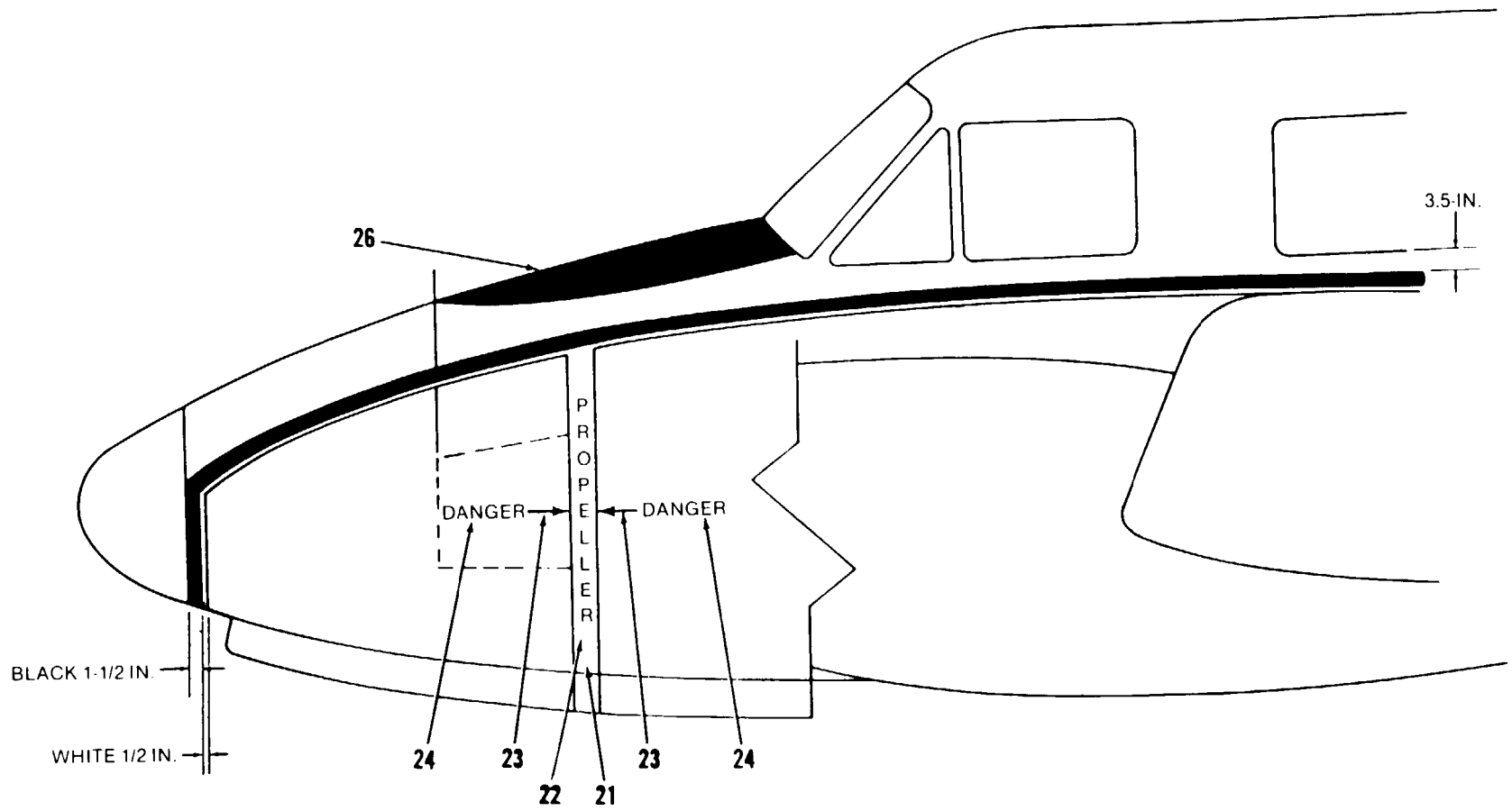


Figure 10-16. Exterior Markings, U-8F (Sheet 7 of 11)


CODE NO.	DIRECTIONS	WORDING
1	Left and right side of fuselage near tail below discharge outlet. 1/2-in. yellow letters.	STATIC AIR KEEP CLEAN
2	Outbd side of each nacelle on rectangular door. 1/2-in. yellow letters.	ACCESS FOR FIRE EXTINGUISHING
3	Outbd side of left nacelle under leading edge of wing on access plate. 1/2-in. yellow letters.	EXTERNAL POWER 24 VOLT
4	Outbd side of each nacelle under wing above exhaust. 1/2-in. yellow letters.	CAUTION: DISCONNECT ELECTRICAL WIRING AND PLUMBING BEFORE REMOVING WING
5	Left side of fuselage fwd of cabin door. 1/2-in. yellow letters on OD or black letters on white.	LEVEL POINT
6	Left side of fuselage fwd of cabin door. 1/2-in. red letters on white.	FIRE EXTINGUISHER INSIDE
7	Left side of fuselage fwd of cabin door. 1/4-in. yellow letters on OD or black letters on white.	LEVEL POINT
8	Fwd left side of fuselage under cockpit window. 1-in. yellow letters.	U.S. ARMY U-8F U.S.A. SERIAL NO. (insert serial no.)
9	Left and right side of fuselage near tie down skid and under side of each wing near tip. Four places. 1/2-in. yellow letters.	TIE DOWN
10	Top trailing edge of ailerons and flaps. Six places. 1/2-in. yellow letters.	NO PUSH
11	Top of flaps and wings, left and right side. Aft stencils to be read facing fwd. Fwd stencils to be read facing aft. Six places. 1/2-in. yellow letters.	NO STEP
12	Paint a black ground symbol, shade 37038, dimensions per MIL-C-83413/9-2.	
13	Fwd side of fuel filler caps. Top of letters facing aft. Four places. 1/2-in. white letters.	FUEL MIL-G-5572 115/145

Figure 10-16. Exterior Markings, U-8F (Sheet 8 of 11)

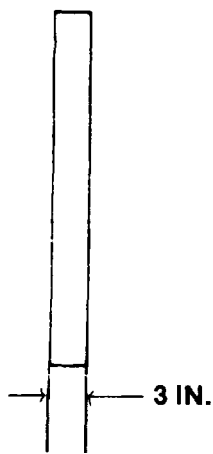
CODE NO.	DIRECTIONS	WORDING
14	Top of each nacelle. 1/2-in. yellow letters. 1-in. yellow band around access door.	OIL MIL-L-22851 TYPE II ABOVE 60°F TYPE III + 5° to 60° F MIL-L-15016 GRADE 3050 BELOW 5°F
15	Top of wing inbd of nacelle and on top of nose section. 1/2-in. yellow letters.	HOIST
16	Bottom side of fuselage and inbd wing. Three places. 1/2-in. yellow letters. Paint jack pad.	JACK PAD
17	<p>1. Fuselage. The dia of the basic blue circle is 20 in. Star is centered on horizontal strip with tip of fwd star bar at STA 267.</p> <p>2. Wing. The dia of the basic blue circle is 22 in. Center of star 80 in. from tip of wing.</p>	(National Star Insignia)
18	Wings. Letters to be 22 in. high X 12-in. wide (Letter M 16-in. wide) X 3-3/4-in. stroke.	U.S. ARMY
19	Leading edge of left nose landing gear door. 1/2-in. letters.	TIRE PRESSURE 35 PSI
20	Center on inbd main landing gear doors. 1/2-in. letters.	TIRE PRESSURE 40 PSI
21	<p>A 3-in. red band around fuselage. The center of the band to be centered on the travel of the propeller tip. On arctic and jungle aircraft, the red band will start at the antiglare and go around the fuselage up to the antiglare on the opposite side.</p> <p>On CONUS aircraft, the red band will go from the underside of the black stripe under the aircraft to the underside of the black stripe on the opposite side.</p>	

Figure 10-16. Exterior Markings, U-8F (Sheet 9 of 11)

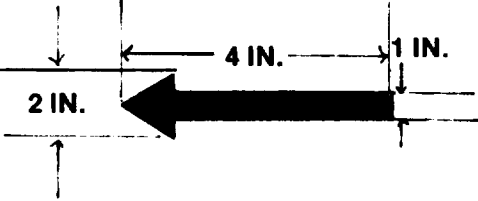
CODE NO.	DIRECTIONS	WORDING
22	2-in. white letters, proportionally spaced on the red band so the word will extend on the side of fuselage only. Do not extend to underside of fuselage or nose landing gear door.	<p style="text-align: center;">P R O P E L L E R</p>
23	Left and right side of fuselage on fwd and aft side of 3-in. red band. Arrows to be placed centrally on fuselage. Tip of arrow pointing towards red band. Width of arrow shaft is 1-in. Width of arrow head is 2-in. and length of arrow is 4-in. Arrow will be yellow on OD Black on white aircraft.	
24	Left and right side of fuselage, adjacent to 4-in. arrow. 2-in. yellow letters on OD or black letters on white.	<p style="text-align: center;">DANGER</p>
25	(Not shown) Paint fuel drain lines red and oil drain lines yellow.	
26	Antiglare areas. Fwd of the cockpit area on the fuselage. Fwd most part of curve on top of fuselage will be in line with fwd side of the nose equipment compartment door. Antiglare will also be applied to the upper 1/4 inbd area of the engine nacelle area but shall not extend aft of the engine cowl door assembly.	
27	Emergency cut out area. 1-in. wide markings 26 in. Area located at fuselage STA 228.75 and WL 120. Red stripes on white fuselage, yellow stripes on OD fuselage.	
28	Right side of fuselage within cut out area. Bottom of letters 10-in. below top of cut out lines. 1-in. black letters on white or yellow letters on OD.	<p style="text-align: center;">CUT HERE FOR EMERGENCY RESCUE</p>
29	Lettering 6-in. high. Numbers 8-in. high.	<p style="text-align: center;">U.S. ARMY (Radio Call Numbers)</p>

Figure 10-16. Exterior Markings, U-8F (Sheet 10 of 11)

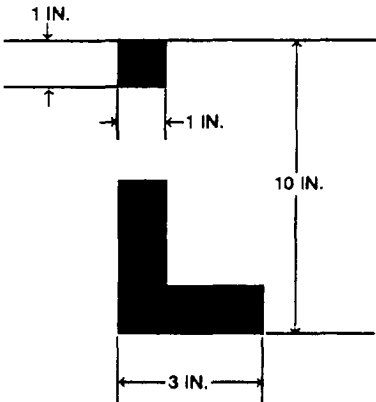
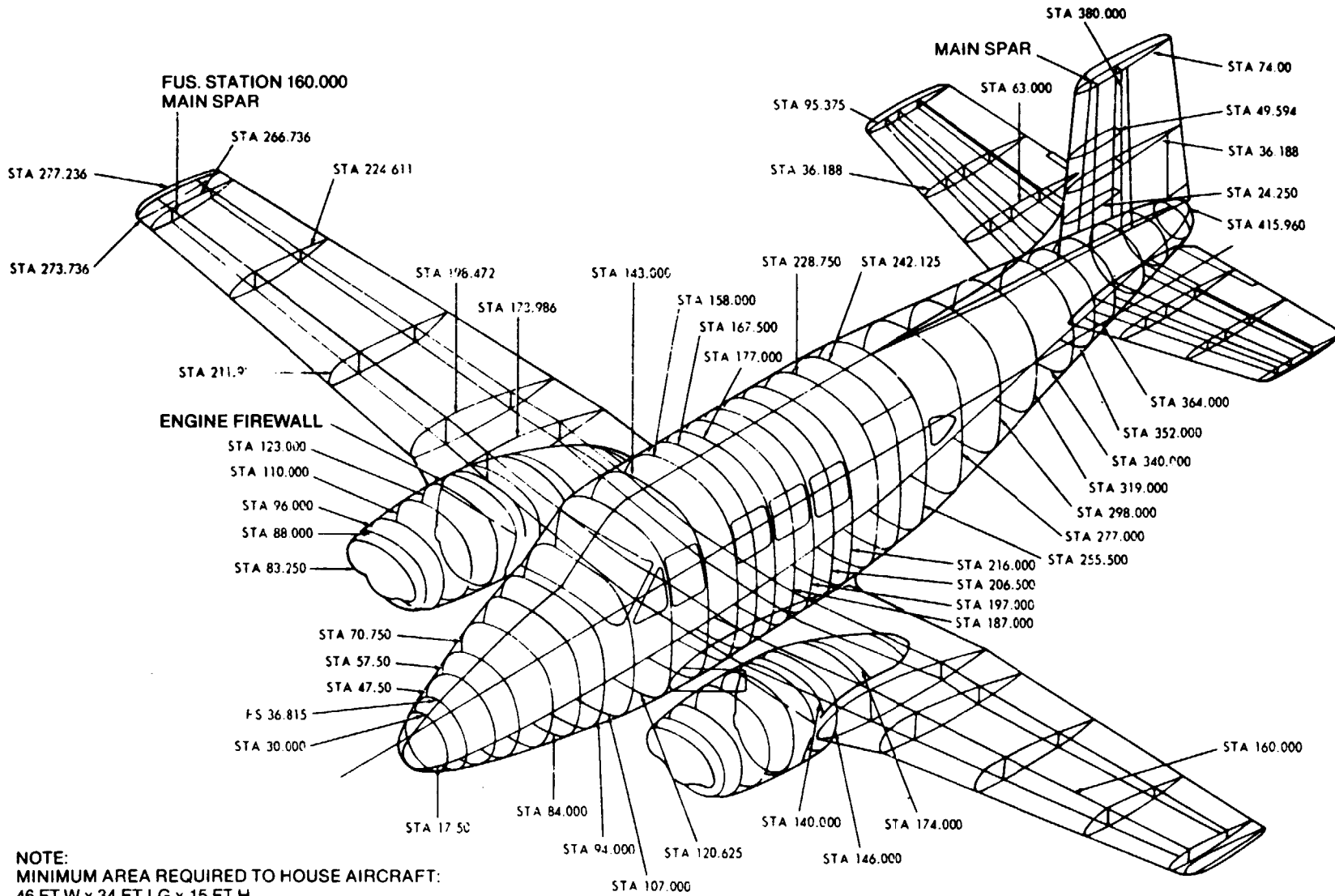
COD NO.	DIRECTIONS	WORDING
30	Left side of fuselage aft of cabin door.	BATTERY LOCATION TOP OF LEFT NACELLE
31	Top of left nacelle.	BATTERY ACCESS
32	Top leading edge of left inbd wing fwd of anti-icer filler cap. Top of letters facing aft. 1/2-in. yellow letters.	PROP ANTI-ICER TANK use T'T-I-735
33	Rear of outboard wing tank filler caps, left and right wing. Top of letters facing aft 1/2-in. yellow letters.	CAUTION DO NOT INSERT FUEL NOZZLE MORE THAN THREE INCHES INTO TANK
34	DELETE	
35	Marking to be centered along top of the existing emergency exit operating instruction placard on interior emergency escape hatch. The word CAUTION will be 3/16 yellow letters on a black background and the text words will be no less than 1/8 inch black letters on a yellow background.	CAUTION DO NOT OPEN ESCAPE HATCH IN FLIGHT.
36	RH aft fuselage around emergency exit. Aircraft black.	

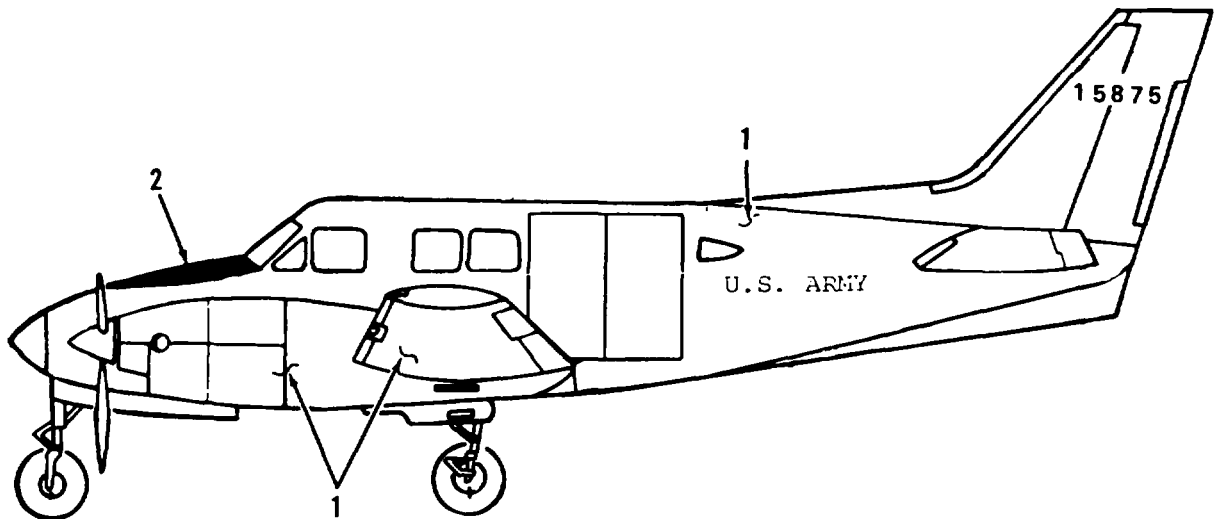
Figure 10-16. Exterior Markings, U-8F (Sheet 11 of 11)



NOTE:
MINIMUM AREA REQUIRED TO HOUSE AIRCRAFT:
46 FT W x 34 FT LG x 15 FT H

Figure 10-17. Station Diagram U-8F

Section VIII. U-21 and RU-21 ILLUSTRATIONS



LEFT SIDE VIEW

- 1. MIL-C-46168. aircraft gray (entire aircraft, except where noted).
- 2. MIL-C-46168 aircraft black.

Figure 10-18. Tactical Paint Scheme, RU-21 (Sheet 1 of 2)

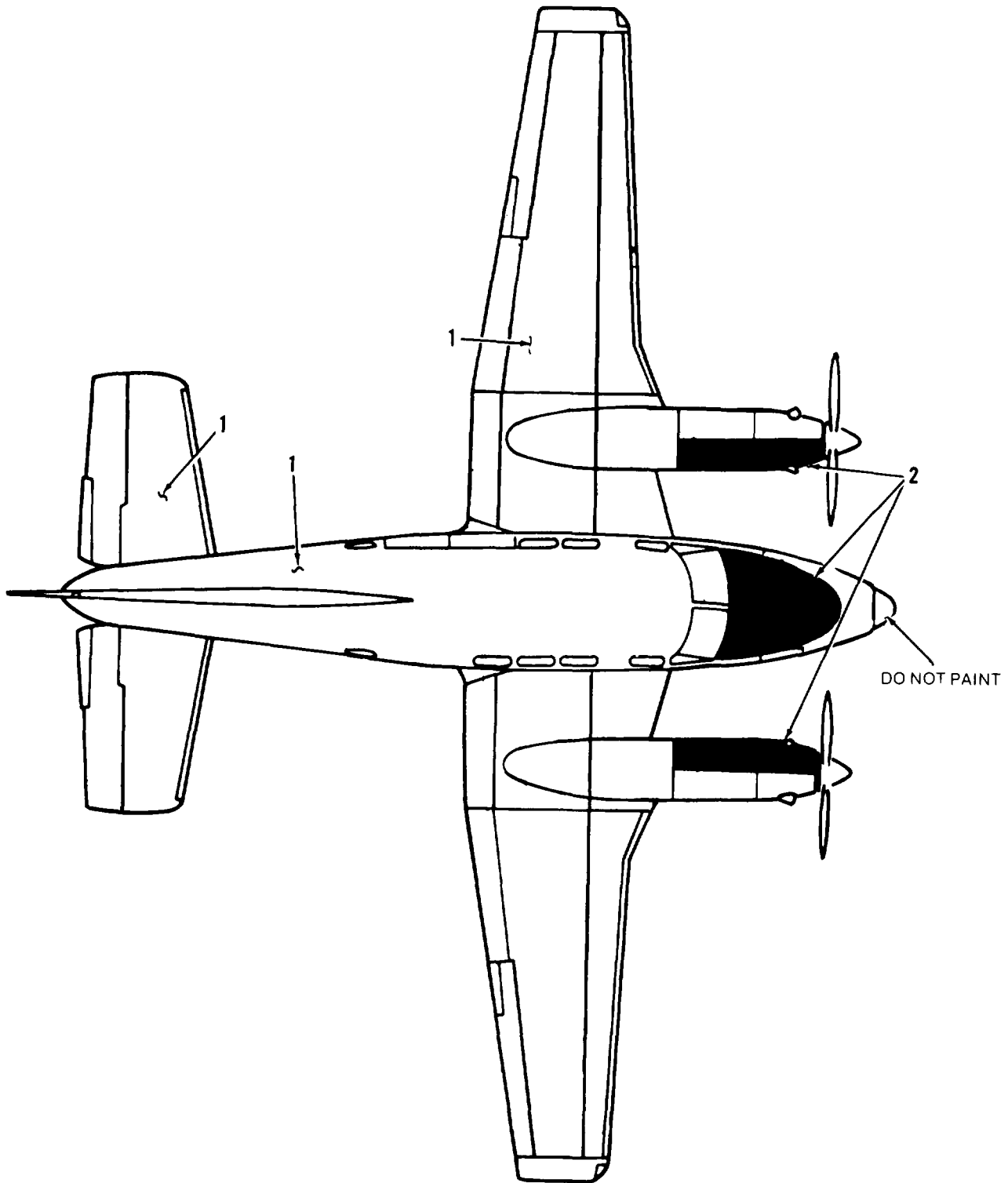
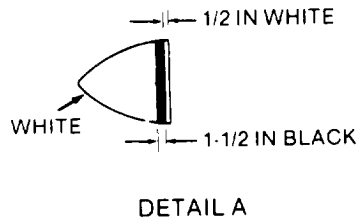
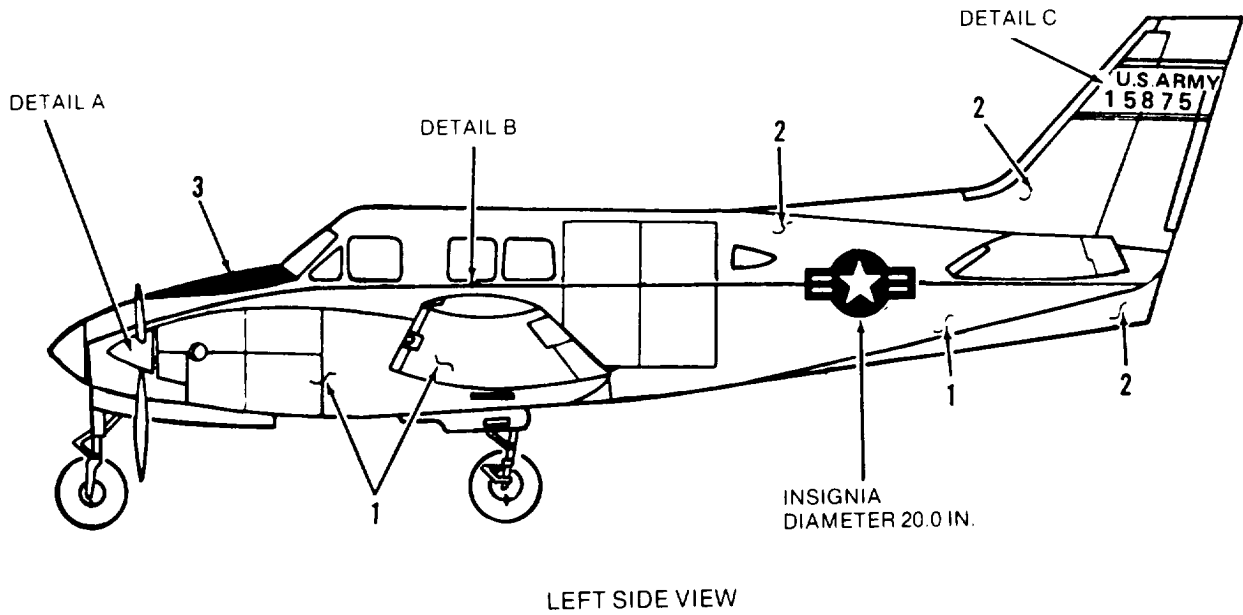


Figure 10-18. Tactical Paint Scheme, RU-21 (Sheet 2 of 2)



1. MIL-C-83286, gloss olive drab, #14087
2. MI L-C-83286, gloss white, #17875.
3. MI L-C-46168, aircraft black.

Figure 10-19. Non-Tactical Paint Scheme, U-21 (Sheet 1 of 4)

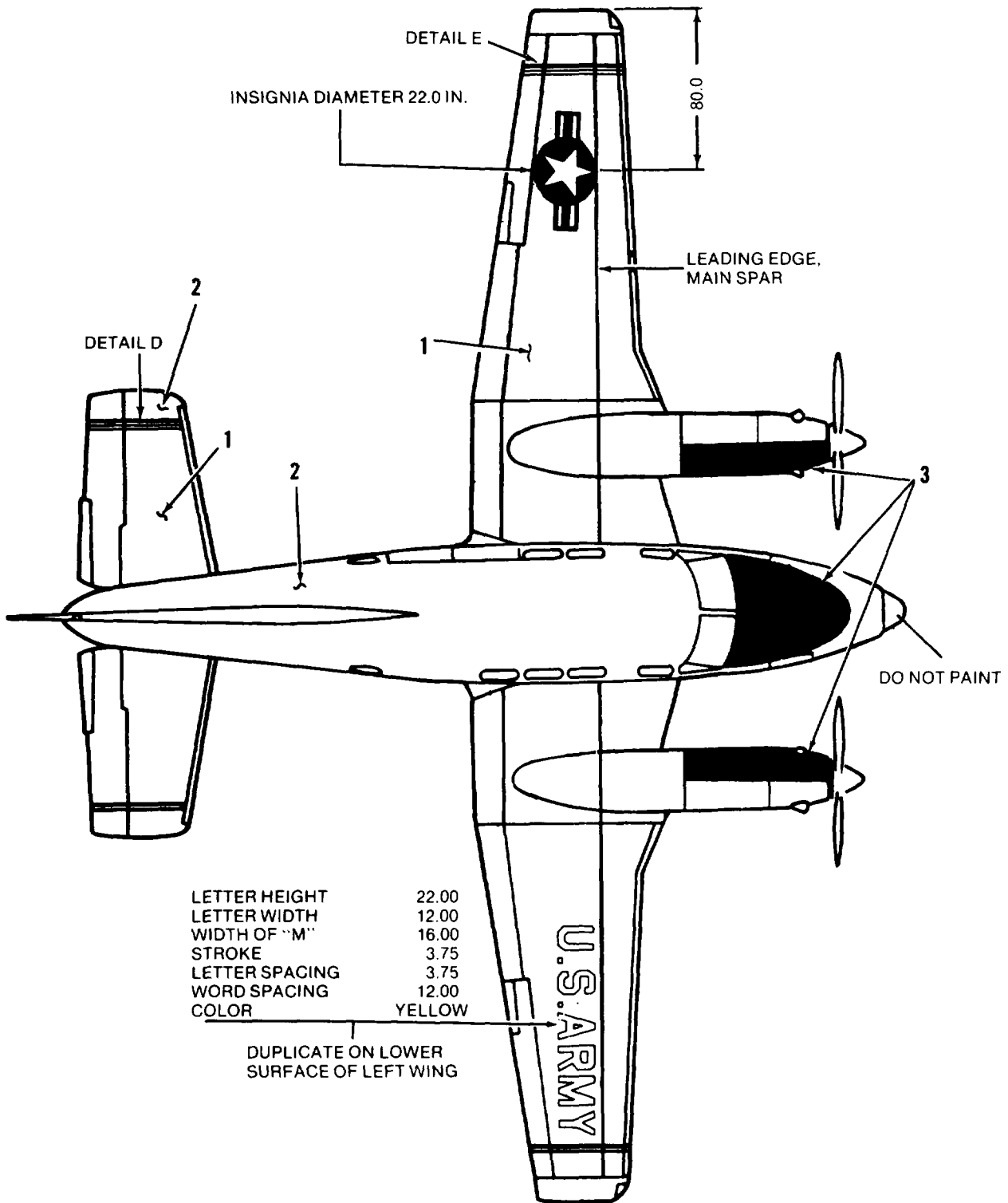
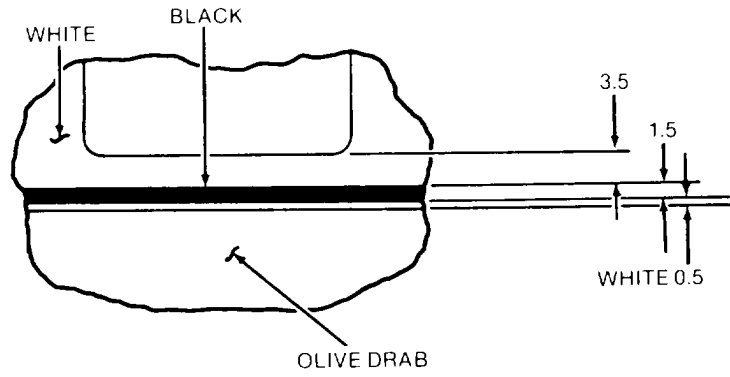
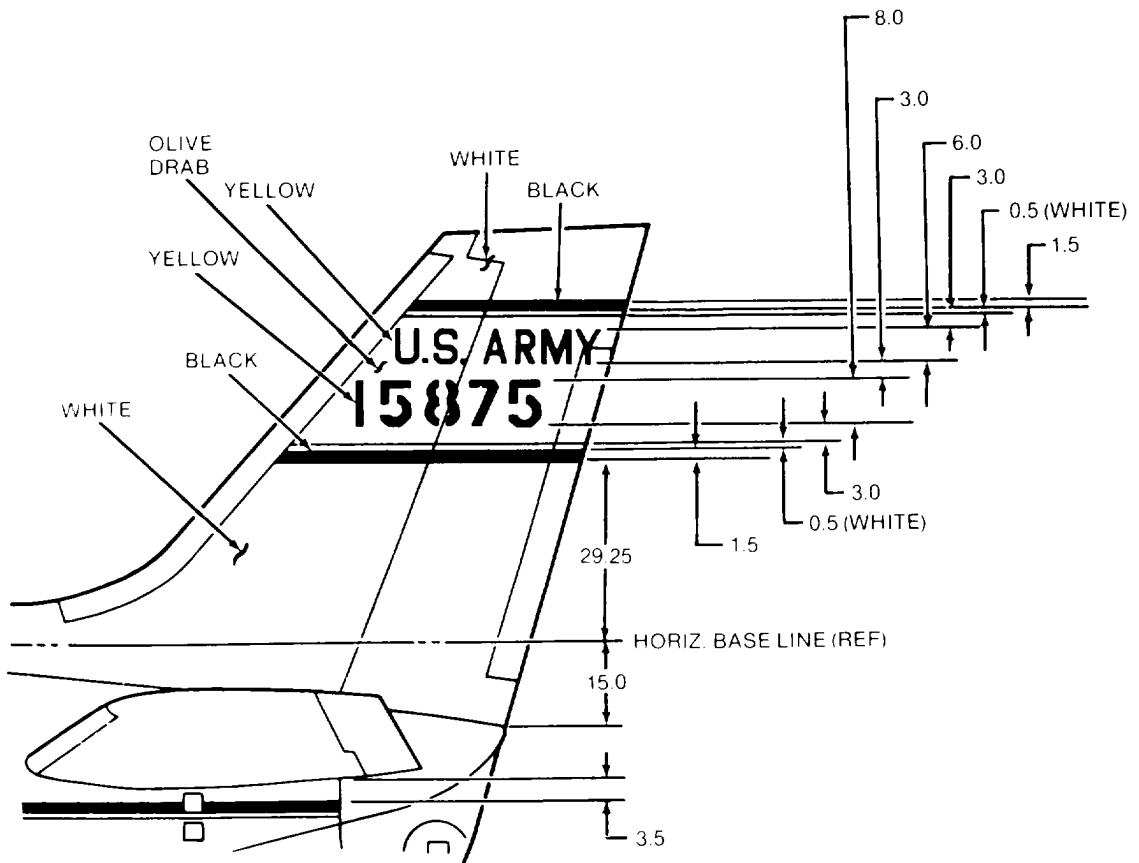


Figure 10-19. Non-Tactical Paint Scheme, U-21 (Sheet 2 of 4)



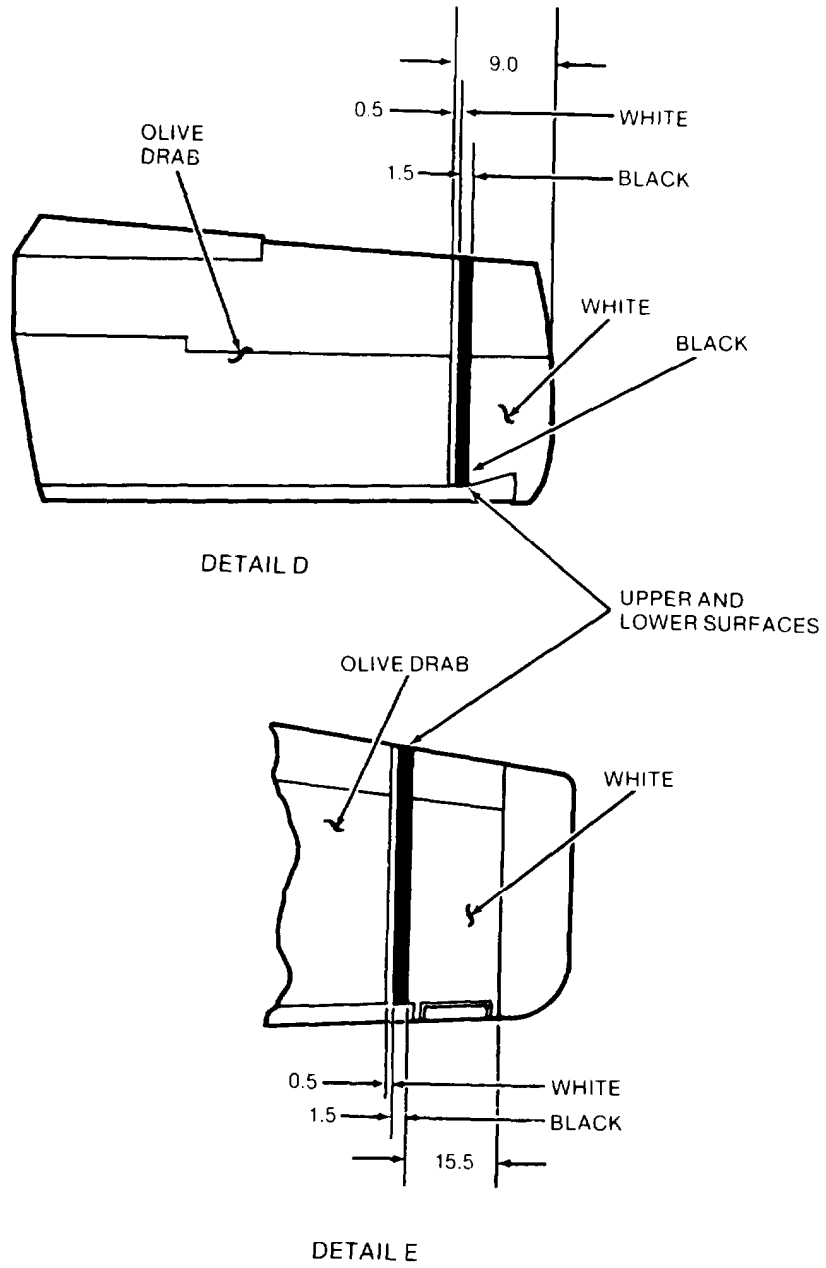
DETAIL B



DETAIL C

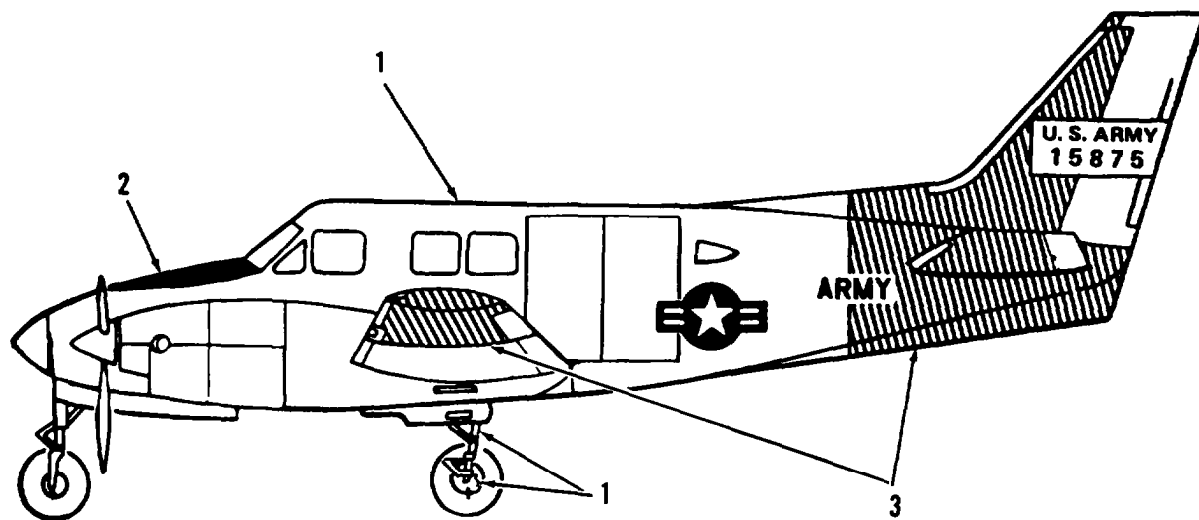
NOTE PAINTS REFERENCED ABOVE ARE GLOSS. PER MIL-C-83286.

Figure 10-19. Non-Tactical Paint Scheme. U-21 (Sheet 3 of 4)

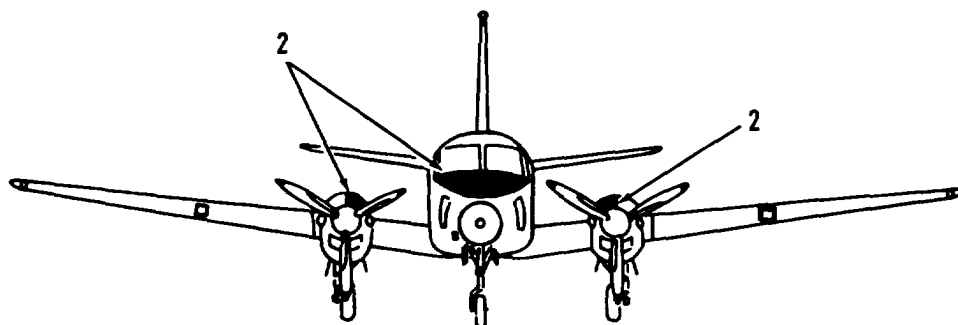


NOTE: PAINTS REFERENCED ABOVE ARE GLOSS. PER MIL-C-83286.

Figure 10-19, Non-Tactical Paint Scheme, U-21 (Sheet 4 of 4)



LEFT SIDE VIEW



FRONT VIEW

1. MI L-C-83286. gloss white. #17875.
2. MI L-C-46168. aircraft black.
3. MIL-P-21600. flourescent red-orange. ANA #633 (only where authorized.)

Figure 10-20. Non-Tactical, High Visibility Paint Scheme, U-21 (Sheet 1 of 2)

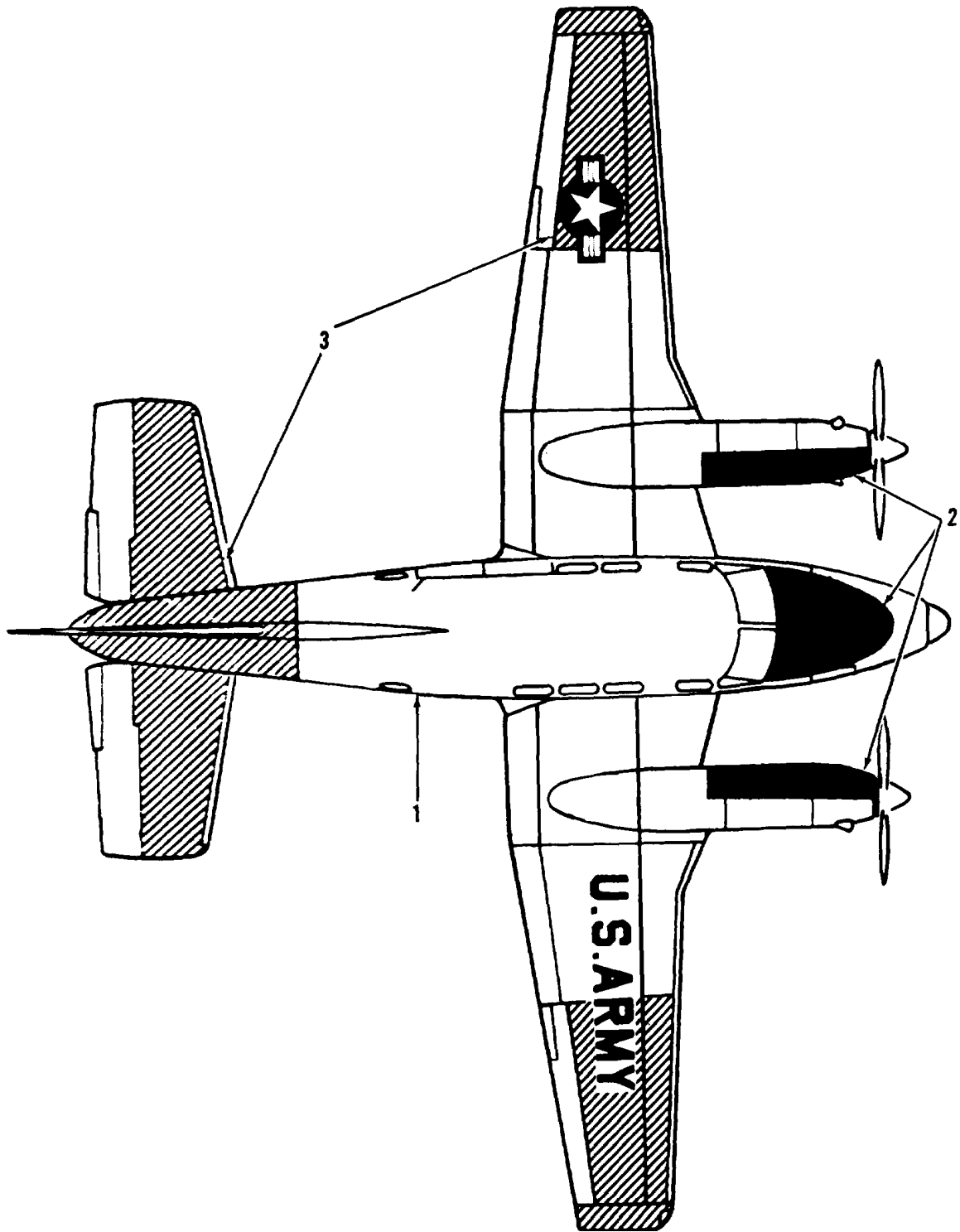
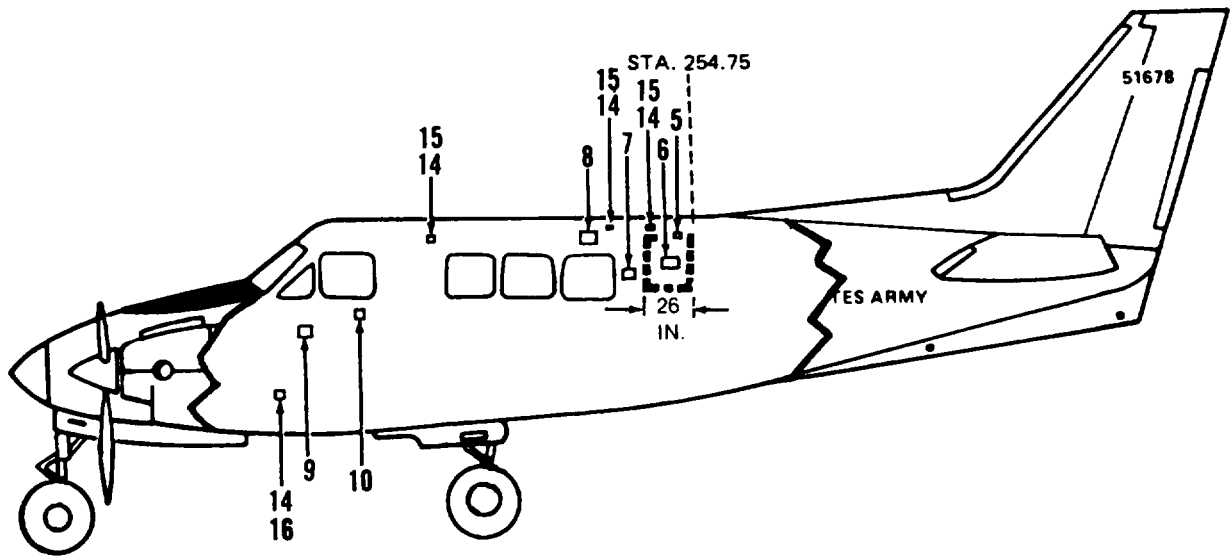
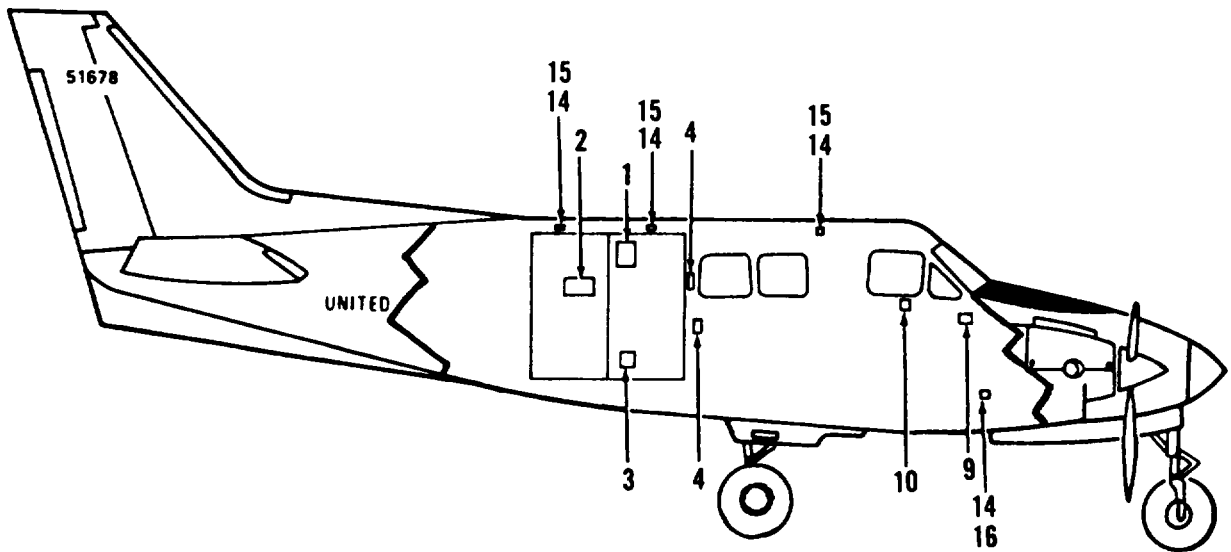


Figure 10-20, Non-Tactical. High Visibility Paint Scheme, U-21 (Sheet 2 of 2)



RIGHT SIDE VIEW



LEFT SIDE VIEW

Figure 10-21. Interior Markings, U-21 and RU-21 (Sheet 1 of 5)

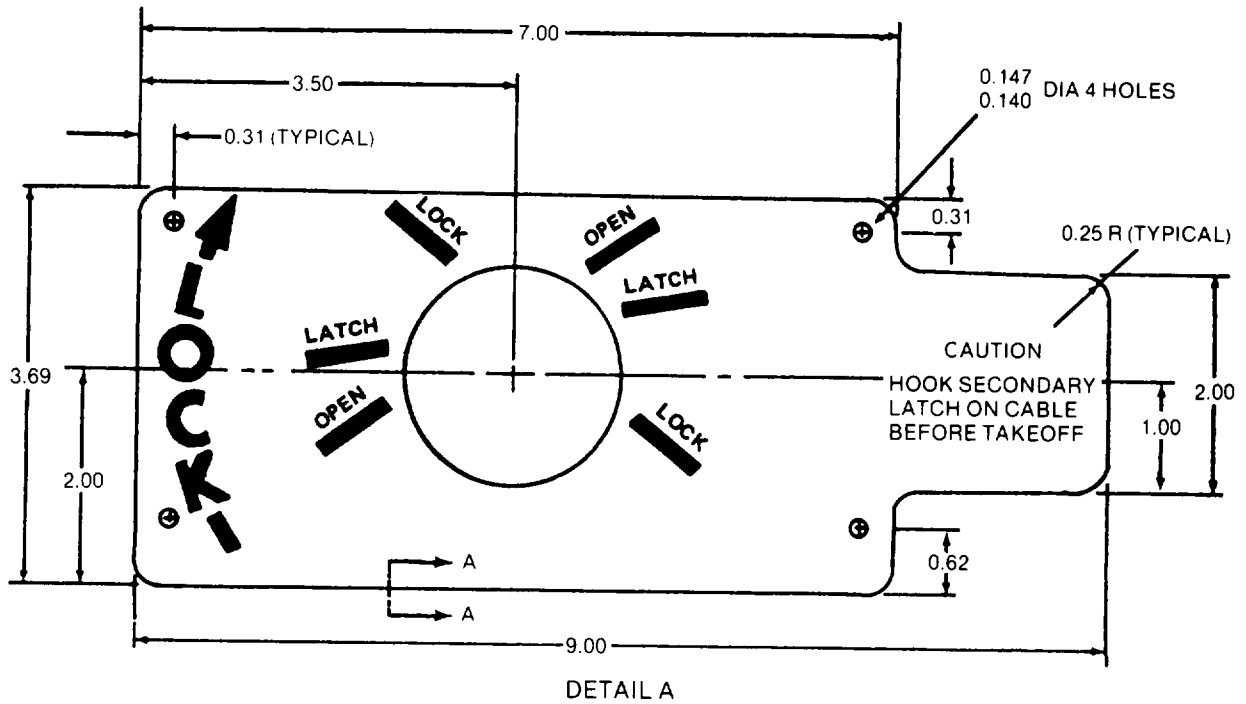
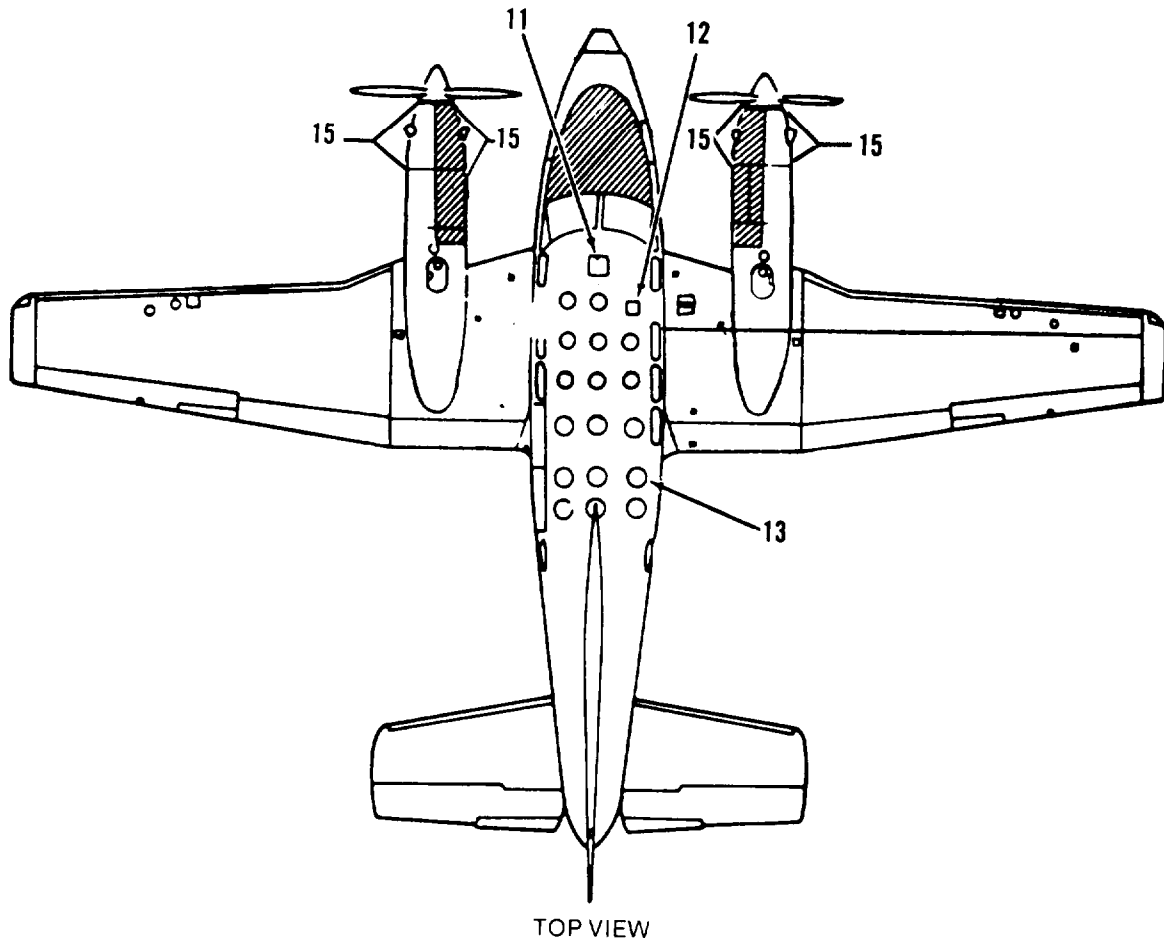


Figure 10-21. interior Markings, U-21 and RU-21 (Sheet 2 Of 5)

CODE NO.	DIRECTIONS	WORDING
1	Locate placard top edge of door forward of STA 228.75	<div style="border: 1px solid black; padding: 5px; text-align: center;"> <p>CARGO DOOR LATCH INSIDE</p> <p>PULL LATCH HANDLE OUT AND DOWN TO UNLOCK</p> <p>CAUTION: LATCH PIN UP AND COVER LOCKED FOR FLIGHT</p> </div>
2	Locate placard over center of door shaft. Background yellow. Cover placard with 0.12 in. acrylic plastic sheet 3.70 in. by 9.0 in., bevel edges of plastic sheet 45° (See detail A)	
3	Locate placard bottom edge of door forward of STA 228.75	<div style="border: 1px solid black; padding: 5px; text-align: center;"> <p>CARGO DOOR LATCH INSIDE</p> <p>PULL LATCH HANDLE OUT AND UP TO UNLOCK</p> <p>CAUTION: LATCH PIN DOWN AND COVER LOCKED FOR FLIGHT</p> </div>
4	Locate placards forward of cargo door. Top placard is aligned with bottom of window frame, bottom placard is directly below top placard and above floor (approx.)	<div style="border: 1px solid black; padding: 10px; text-align: center;"> <p>REMOVE FOR ACCESS TO CARGO DOOR HINGE</p> </div>
5	Paint inside of right fuselage skin and face of upholstery panel at the same location as the exterior markings, STA 254.75 WL 120.0 to WL 146.0. Marking will be yellow, shade No. 13538	

Figure 10-21. Interior Markings, U-21 and RU-21 (Sheet 3 of 5)

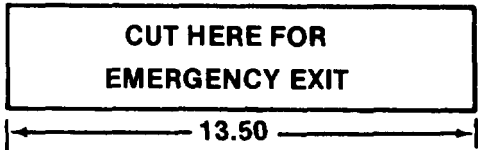
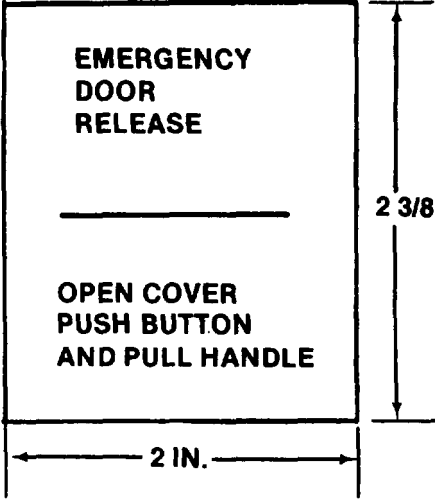
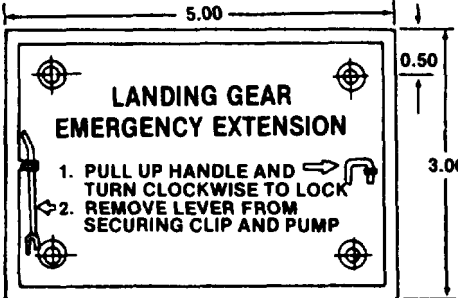
CODE NO.	DIRECTIONS	WORDING
6	Locate decal in center of emergency exit markings (code No. 5) and 11 in. from top edge of markings. Black letters on yellow background.	 <p style="text-align: center;">CUT HERE FOR EMERGENCY EXIT</p>
7	Locate EMERGENCY DOOR RELEASE placard aft of escape hatch and below handle, right side fuselage.	 <p style="text-align: center;">EMERGENCY DOOR RELEASE</p> <p style="text-align: center;">—</p> <p style="text-align: center;">OPEN COVER PUSH BUTTON AND PULL HANDLE</p>
8	Center decal above escape latch and on STA 228.75.	EMERGENCY EXIT
9	Right side of aircraft on static air line drain door.	
10	Right side of aircraft cockpit aft of STA 122.0 and 0.75 in. forward of inertia reel harness lock on inboard surface of window escutcheon.	<div style="border: 1px solid black; padding: 5px; width: fit-content; margin: auto;"> <p>CO-PILOT SEAT MUST BE IN FORWARD POSITION DURING TAKE . OFF & LANDING</p> </div>
11	Locate placard on fuselage floor, centered on STA 130.0 and left edge of placard 6.2 in. left of aircraft centerline. Placard is metal etched on anodized red background.	 <p style="text-align: center;">LANDING GEAR EMERGENCY EXTENSION</p> <ol style="list-style-type: none"> 1. PULL UP HANDLE AND TURN CLOCKWISE TO LOCK 2. REMOVE LEVER FROM SECURING CLIP AND PUMP

Figure 10-21. Interior Markings, U-21 and RU-21 (Sheet 4 of 5)

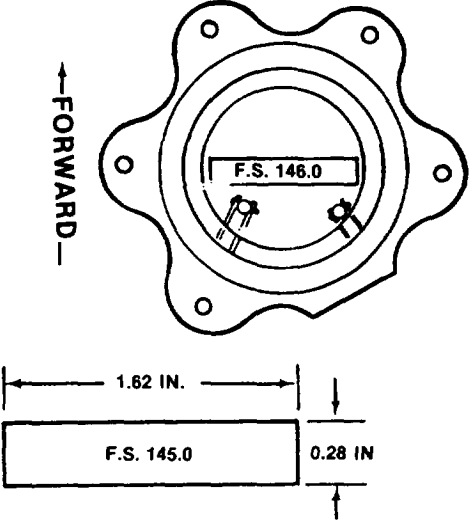
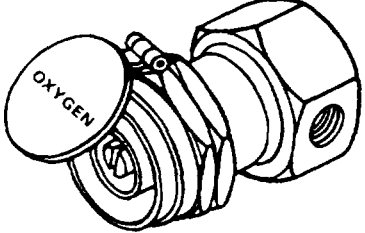
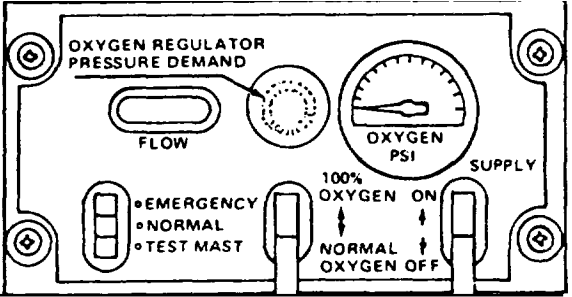
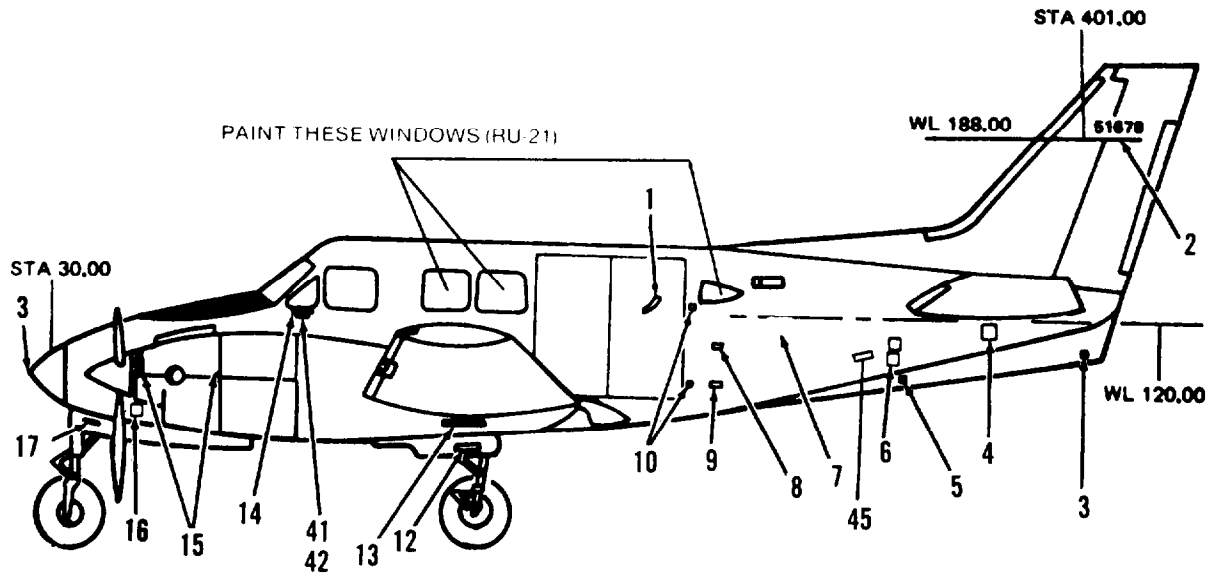
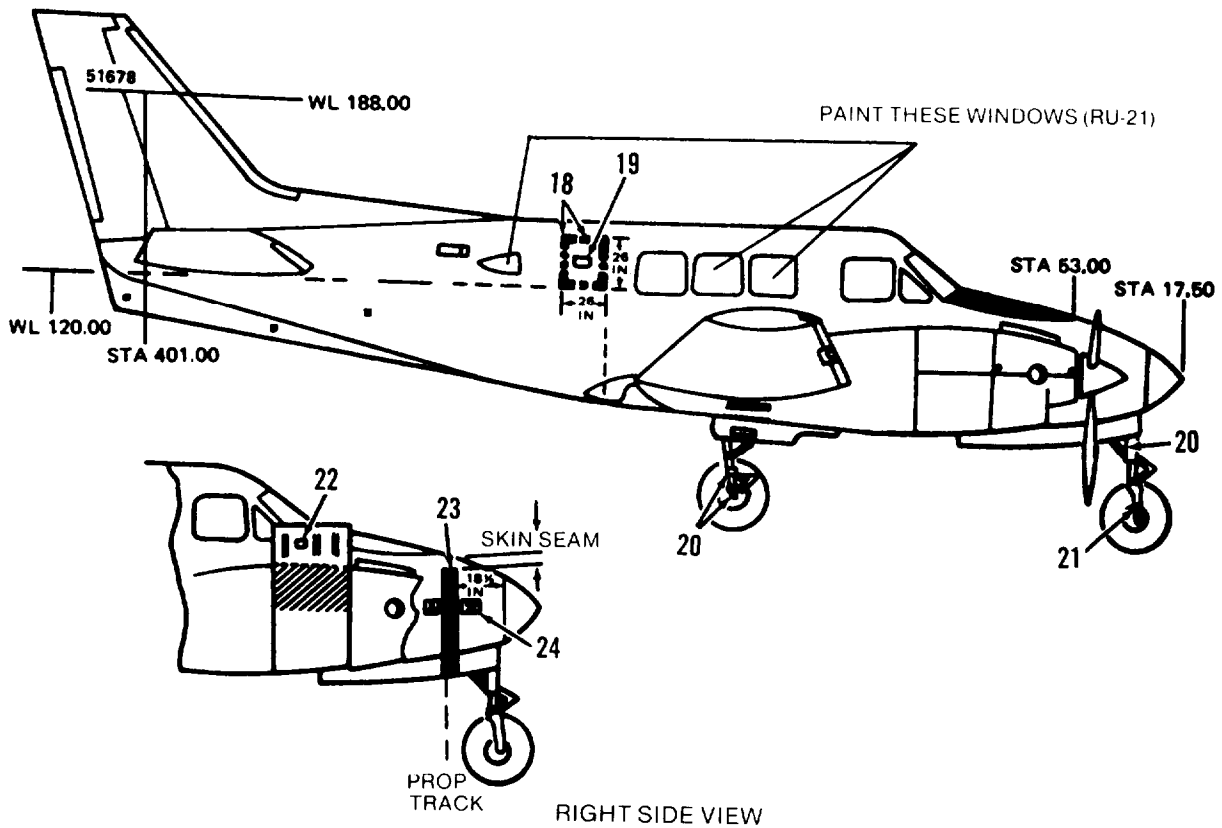
CODE NO.	DIRECTIONS	WORDING
12	Locate decal on aft side of spar cover and 11 in. to right of aircraft centerline	MAXIMUM LOAD PER TIEDOWN: 200 LB.
13	<p>Center decals in tiedown fittings as shown, top of letters foward. Lettering is black.</p> <p>F.S. 145.0 F.S. 146.0 F.S. 163.8 F.S. 165.4 F.S. 179.8 F.S. 181.5 F.S. 199.7 F.S. 200.6 F.S. 218.7 F.S. 219.6 F.S. 239.2 F.S. 239.9 F.S. 240.2</p>	
14	Locate marking near each oxygen outlet. Warning 1/4-in. letters, text 1/8-in. gloss red letters on yellow background.	WARNING NO SMOKING WHILE OXYGEN IN USE
15	Passenger oxygen outlet	
16	Pilot and copilot's Diluter demand regulator	

Figure 10-21. Interior Markings, U-21 and RU-21 (Sheet 5 of 5)

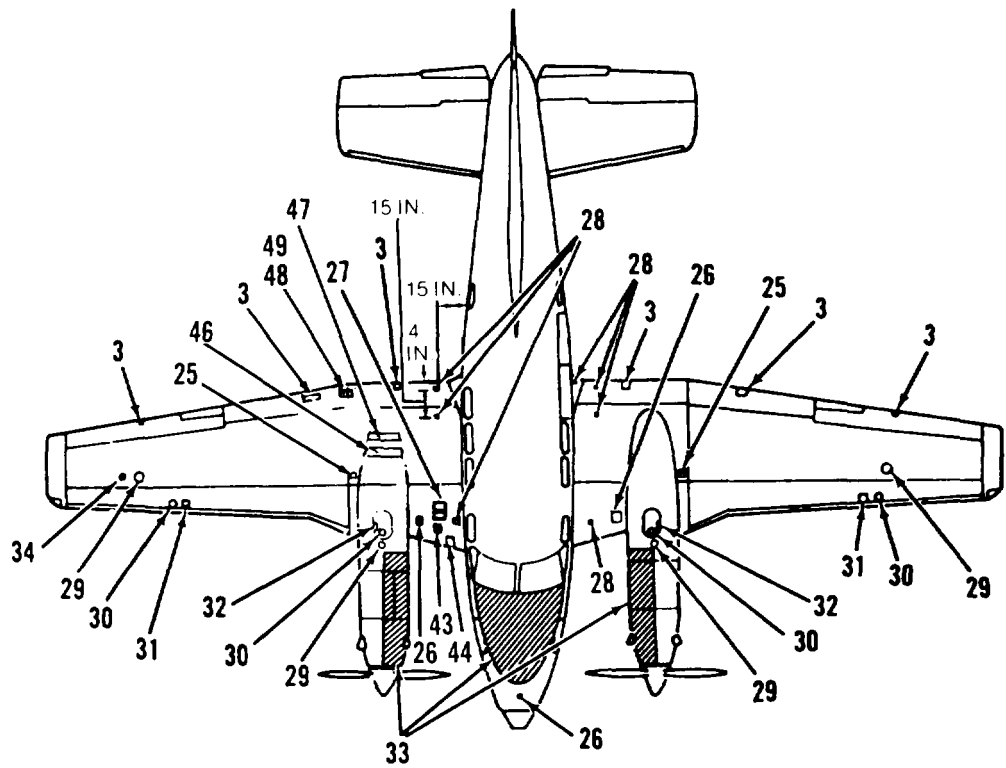


LEFT SIDE VIEW

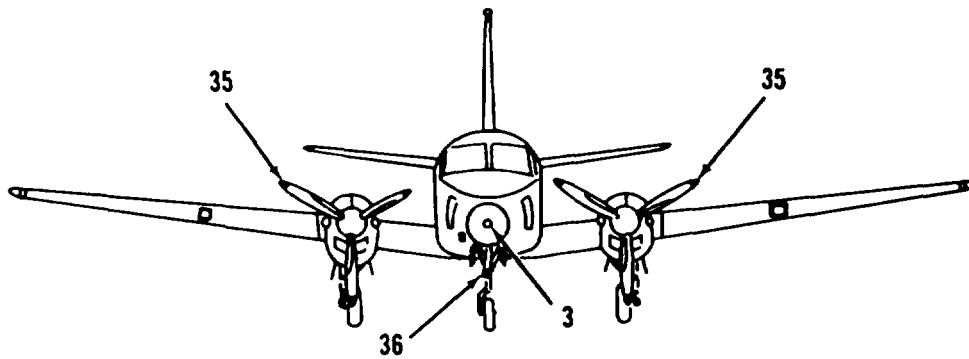


RIGHT SIDE VIEW

Figure 10-22. Exterior Markings, U-21 and RU-21 (Sheet 1 of 13)

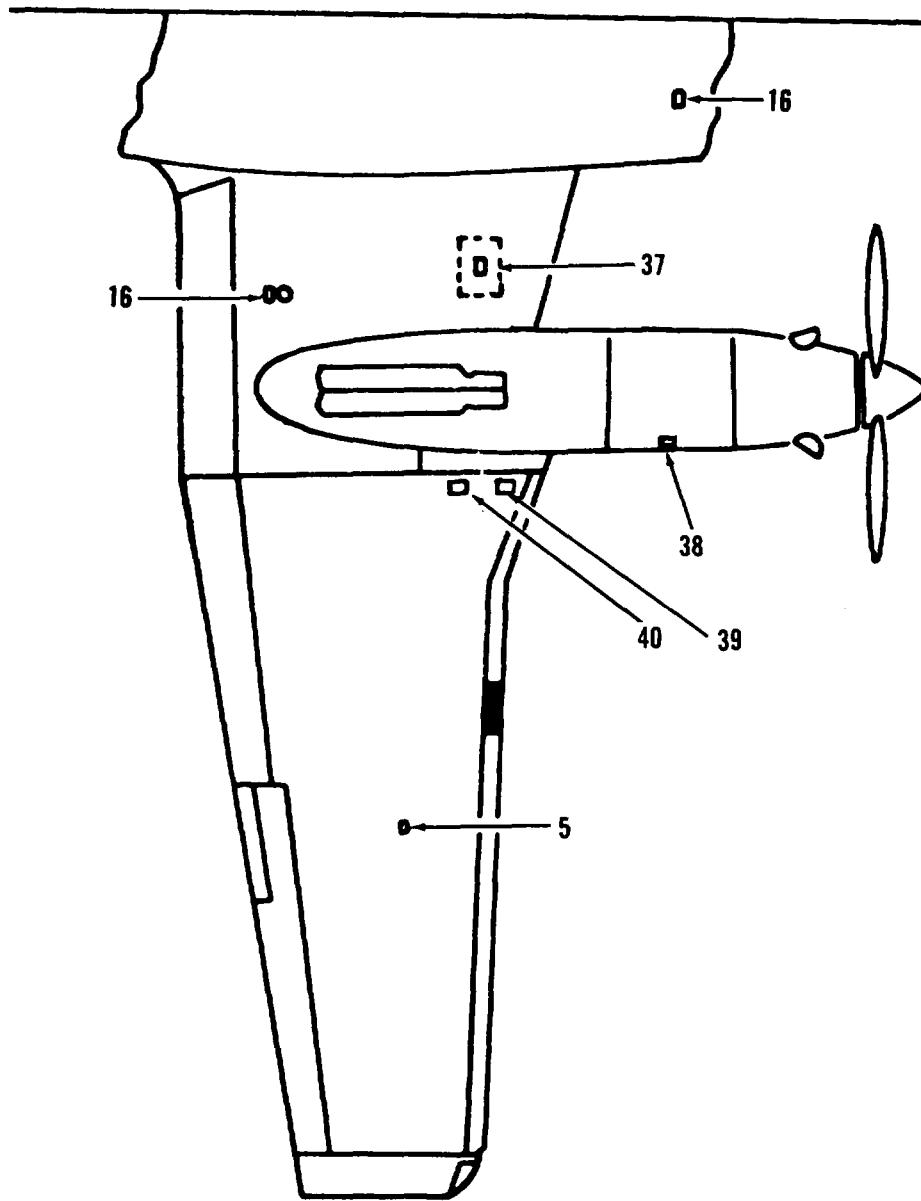


TOP VIEW



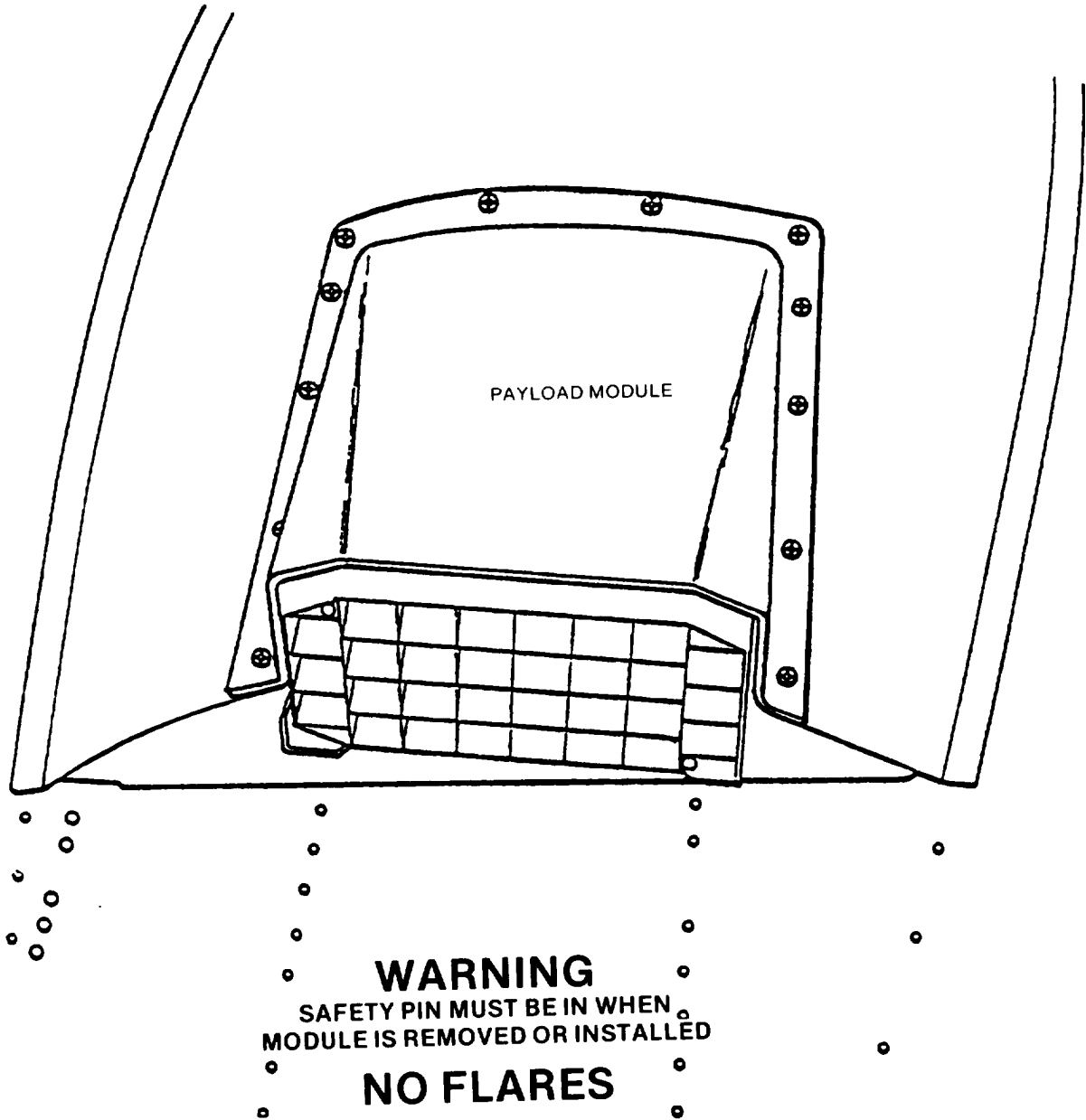
FRONT VIEW

Figure 10-22. Exterior Markings, U-21 and RU-21 (Sheet 2 of 13)



BOTTOM VIEW — LEFT SIDE

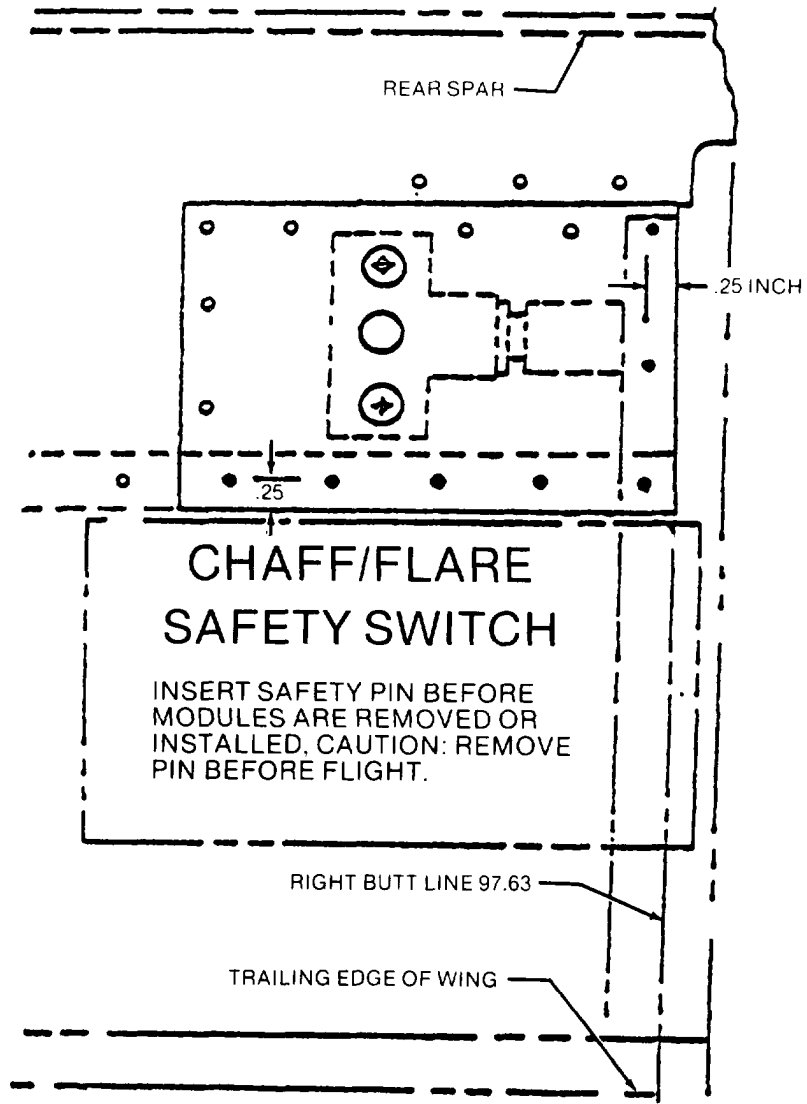
Figure 10-22 Exterior Markings. U-21 and RU-21 (Sheet 3 of 13)



Installation of Aft Nacelle Fairing, Decal, and Payload Module

DETAIL A

Figure 10-22. Exterior Markings. U-21 and RU-21 (Sheet 4 of 13)



DETAIL B

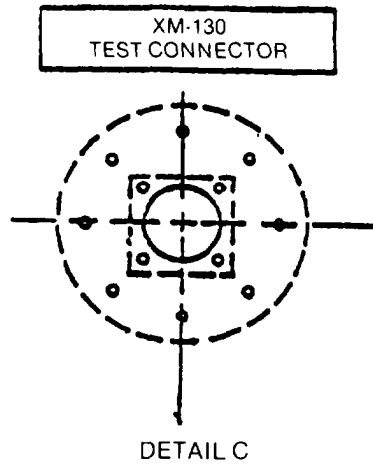


Figure 10-22. Exterior Markings, U-21 and RU-21 (Sheet 5 of 13)

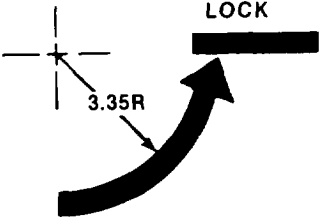
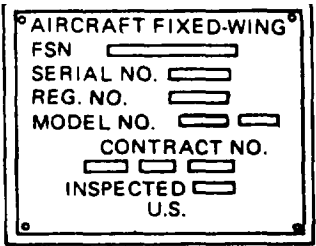
CODE NO.	DIRECTIONS	WORDING
	<p align="center">NOTE</p> <p>Only MIL-C-46168 paints will be used on RU-21 aircraft unless otherwise specified.</p>	
	<p>Left side of fuselage on entrance air step door, adjacent to handle, 1/2-in. black letters and arrow. Lines are 1/8 in. wide, arrowhead 3/8 in. wide.</p>	
2	<p>RADIO CALL NUMBERS Left and right side of vertical stabilizer, 6-in. lusterless black numerals, STA 401.00, WL 188.00.</p>	
3	<p>Both sides of ventral fin, center top trailing edge of each aileron, also center on nose cone using black letters.</p>	<p align="center">NO PUSH</p>
4	<p>Aircraft data plate located on left side of aircraft under horizontal stabilizer.</p>	
5	<p>Left and right side of aft fuselage and bottom center of each outboard wing panel. Black 1/2-in. letters. Top of letters up or towards spar.</p>	<p>TIE DOWN</p>
6	<p>Left and right side of fuselage below static port, 1/2-in. black letters. Do not paint static port.</p>	<p>STATIC AIR KEEP CLEAN</p>

Figure 10-22. Exterior Markings, U-21 and RU-21 (Sheet 6 of 13)


CODE NO.	DIRECTIONS	WORDING
7	<p>U-21, both sides of fuselage, 20 in. dia. basic blue circle, center vertically. Bottom of top star frame in line with green/white seam.</p> <p>RU-21, left and right side of fuselage, 6-in. black letters. Center between aft edge of cabin door and line even with front of horizontal stabilizer. Top of letters on WL 120.0.</p>	<p>(National Star Insignia)</p> <p>U.S. ARMY</p>
8	<p>Left side of fuselage aft of entrance door frame, 1/2-in. black letters.</p>	<p>FIRE EXTINGUISHER INSIDE</p>
9	<p>Left side of fuselage aft of entrance door frame, 1/2-in. black letters.</p>	<p>BATTERY LOCATION TOP OF RIGHT HAND WING STUB</p>
10	<p>Left side of fuselage aft of entrance door frame, 1/2-in. black letters.</p>	<p>LEVEL POINT</p>
11	<p>U-21, top of left wing, bottom of right wing - A 22 in. dia. basic blue circle centered 80 in. inboard of wingtip. Point of star facing fwd.</p>	<p>(National Star Insignia)</p>
12	<p>Left and right side of fuselage on each outboard main gear door, 1/2-in. black letters.</p>	<p>NORMAL PRESSURE 46-50 P.S.I.</p>
13	<p>Left and right side of fuselage under wing and on outboard side of each nacelle above main landing gear doors. Black 1/2-in. letters.</p>	<p>CAUTION: DISCONNECT ELECTRICAL WIRING AND PLUMBING BEFORE REMOVING WING</p>
14	<p>Left side of fuselage under cockpit window, 1 in. black letters and numerals. Enter complete model and aircraft serial number.</p>	<p>U.S. ARMY * U.S.A. SERIAL NO. * (*Indent correct model and serial numbers)</p>
15	<p>Left and right side of forward engine cowling. Black 1/8 in. lines and arrow, 1/2-in. black letters, 4 places.</p>	

Figure 10-22. Exterior Markings, U-21 and RU-21 (Sheet 7 of 13)

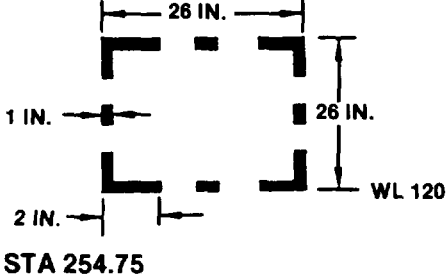
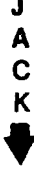
CODE NO.	DIRECTIONS	WORDING
16	Aft end of nose wheel well and left of fuselage centerline. Two jack pads located on bottom of wing stub near rear spar and inboard of each engine nacelle. Black 1/2-in. letters.	JACK PAD
17	Locate on inboard side of left nose gear door, 1/2-in. black letters.	NORMAL TIRE PRESSURE 50-55 P.S.I. VERY SOFT FIELD TAKEOFF 30-32 P.S.I.
18	U-21, paint yellow emergency rescue markings on right side of fuselage at STA 254.75 WL 120.0. RU-21, paint lusterless black.	 <p style="text-align: center;">STA 254.75</p>
19	Right side of fuselage, centered within emergency rescue markings (code No. 18), 1-in. letters, same color shade as markings.	CUT HERE FOR EMERGENCY EXIT
20	U-21, paint landing gear struts and wheels olive drab. RU-21, paint lusterless white.	
21	Locate on outboard side of nose wheel strut. Black 1/2-in. letters, arrow 1 in. long, 1/4 in. shaft and 1/2 in. head.	<p style="text-align: center;">J A C K</p> 
22	Locate on inside of left and right cowling doors. U-21, yellow 1/2-in. letters. RU-21, lusterless black 1/2-in. letters.	LUBE OIL MIL-L-23699 ABOVE -25° F MIL-L-7808 BELOW - 25°F

Figure 10-22. Exterior Markings, U-21 and RU-21 (Sheet 8 of 13)

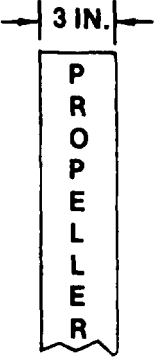
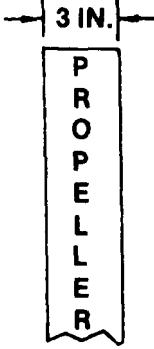


CODE NO.	DIRECTIONS	WORDING
23	U-21 , paint 3 in. red band, from underside of black stripe on left side of fuselage to black stripe on opposite side inline with propeller plane. Locate PROPELLER placard over red band on both sides of fuselage.	
23	RU-21, Paint 3 in. lusterless black stripe, centered on propeller plane, Top of stripe starts at upper corner of fuselage, 4 in. down from skin seam to bottom of nose gear doors. Forward edge of black stripe is approximately 18 1/2 in. aft of nose cone.	
24	U-21, left and right side of forward fuselage, fore and aft of RED/BLACK stripe (code No. 23). Word DANGER is 13 1/2 in. down from top of stripe and is 1 1/4 in. away from edge of stripe. Black 2-in. letters, arrow points toward stripe and is 4 in. long with 1 in. shaft and 1 1/2 in. arrowhead.	<p style="text-align: center;">DANGER</p> 
24	RU-21, left and right side of forward fuselage, fore and aft of BLACK stripe (code No. 23). Word DANGER is 13 1/2 in. down from top of stripe and is 1 1/4 in. away from edge of stripe. Black 2-in. letters, arrow points toward stripe and is 4 in. long with 1 in. shaft and 1 1/2 in. arrow head.	<p style="text-align: center;">DANGER</p> 
25	U-21, outboard of left and right engine nacelles on access doors. Black 1/2-in. letters, top of letters toward spar.	<p>PU-545 INVERTER</p>

Figure 10-22. Exterior Markings, U-21 and RU-21 (Sheet 9 of 13)

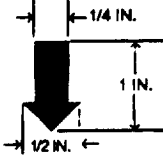

CODE NO.	DIRECTIONS	WORDING
25	RU-21, outboard of left and right engine needles on access doors. Black lettering, letters towards antenna	PU-545 INVERTER
26	Top of nose section forward of antiglare paint. Left and right center wing stub forward of spar and inboard of nacelles. Black 1/2 in. letters with arrow. Top of letters towards spar.	<p>LIFT</p> 
27	Top right inboard wing stub On access cover. Black 1/2 in. letters, top of letters toward spar.	BATTERY ACCESS
28	Top of left and right wing center stub, inboard of needles. Right wing 3 places, left wing 4 places, 1/2 in. black letters.	NO STEP
29	Paint a black ground symbol, shade 37038, dimensions per MIL-C-83413/9-2.	
3 0	DELETE	

Figure 10-22. Exterior Makings, U-21 and RU-21 (Sheet 10 of 13)

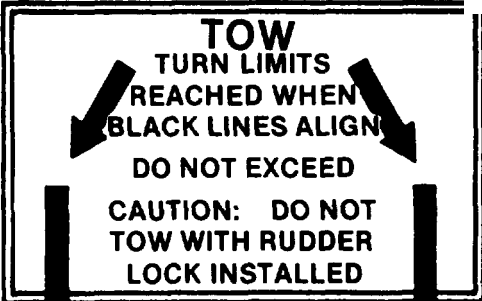
CODE NO.	DIRECTIONS	WORDING
31	Left and right wings, inboard of fuel filler caps (code No. 30). Black 1/2-in. letters, top of letters towards spar, 2 places.	128 Gallons Capacity MIL-T-5624(JP-4) AVIATION KEROSENE CAUTION: NACELLE TANKS MUST BE FULL BEFORE FILLING THIS TANK
32	Top of each engine nacelle, outboard of fuel filler cap. Black 1/2-in. letters, top of letters facing inboard, 2 places.	57 Gallons Capacity MIL-T-5624(JP-4) AVIATION KEROSENE
33	Antiglare areas. Paint inboard upper 1/4 of the left and right nacelles and nose area forward of cockpit windshield to STA 53.0. Paint black.	
34	U-21, top of right outboard wing panel on access door. Yellow 1/2-in. letters top of letters towards spar. RU-21, lusterless black 1/2-in. letters,	ACCESS CN 405/ASN COMPENSATOR T-611/ASN INDUCTION COMPASS CAUTION: USE NON-MAGNETIC SCREWS IN COMPASS
35	U-21, propellers shall not be stripped but will be lightly oversprayed with lusterless black. Do not cover index mark on rear of blade, or serial numbers and data on front of blades. Yellow tip 4-in. wide on front of blade only. For high visibility paint scheme for propellers and spinners, see Chapter 6.	
35	RU-21, propellers shall not be stripped but will be lightly oversprayed with aircraft black. Do not cover index mark on rear of blade, or serial numbers and data on front of blades. Yellow tip 4 in. wide on front of blade only.	
36	Front of nose gear strut. Portect during paint stripping. TOW, 1/2-in. letters, remainder 1/4-in. with arrows and stripes. Paint black.	

Figure 10-22. Exterior Markings, U-21 and RU-21 (Sheet 11 of 13)

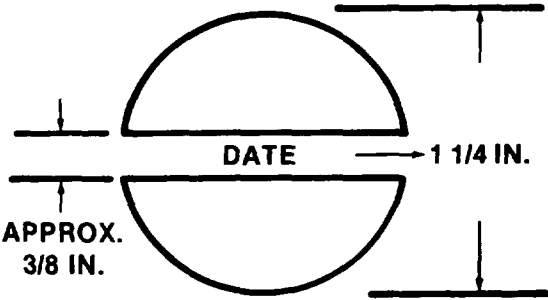
CODE NO.	DIRECTIONS	WORDING	
37	U-21, bottom of left and right center wing stub on access door. Yellow 1/2-in. letters, top of letters towards spar.	REMOVE FOR ACCESS TO ARC-51	
38	Bottom of left and right outboard engine nacelles. Black 1/2-in. letters.	OIL COOLER DRAIN	
39	U-21, bottom of left and right outboard wing panels. Locate 1 in. forward of power receptacle door. Yellow 1/2-in. letters, top of letters towards spar RU-21, lusterless black 1/2-in. letters.	(Left Wing)	A.C. EXTERNAL POWER
		(Right Wing)	EXTERNAL POWER 24 VOLTS
40	Bottom of right wing, outboard of engine nacelle and forward of spar. Black 1/2-in. letters, top of letters towards spar.	SEE OPERATOR'S MANUAL FOR INVERTER OPERATION	
41	Left side of fuselage under model designator (code No. 14) Black 1/4-in. letters. ** Contractor will insert their code.	**WP1-P2-L3 Date WP- indicates wash primer used P - indicates primer used L - indicates lacquer used (if req'd) C . indicates coating used (if req'd)	
42	Stencil below Code 41. NOTE: Date shown on stencil is date aircraft painted with MI L-C-46168 paint.		
43	U-21, top and bottom of right hand inboard wing aft of battery vent tubes. Paint black.	Battery Vent	
44	U-21, leading edge of right inboard wing. Paint black.	PITOT Drain	
45	RU-21, center 1 in. over oxygen access cover. Paint black.	OXYGEN	

Figure 10-22. Exterior Markings, U-21 and RU-21 (Sheet 12 of 13)

CODE NO.	DIRECTIONS	WORDING
46	RU-21, top right wing, centered aft of engine nacelle, chaff dispensor (see detail A). Paint black.	<p style="text-align: center;">WARNING</p> <p style="text-align: center;">SAFETY PIN MUST BE IN WHEN MODULE IS REMOVED OR INSTALLED</p>
47	RU-21, top right wing, centered aft of engine nacelle, chaff dispensor (see detail A). Paint black.	<p style="text-align: center;">NO FLARES</p>
48	RU-21, top of right wing behind safety pin receptacle (see detail B). Paint black.	<p style="text-align: center;">CHAFF/FLARE SAFETY SWITCH</p> <p style="text-align: center;">INSERT SAFETY PIN BEFORE MODULES ARE REMOVED OR INSTALLED. CAUTION: REMOVE PIN BEFORE FLIGHT.</p>
49	RU-21, top right wing behind safety pin receptacle (see detail B). Paint black.	<p style="text-align: center;">M-130 TEST CONNECTOR</p>

Figure 10-22. Exterior Markings, U-21 and RU-21 (Sheet 13 of 13)

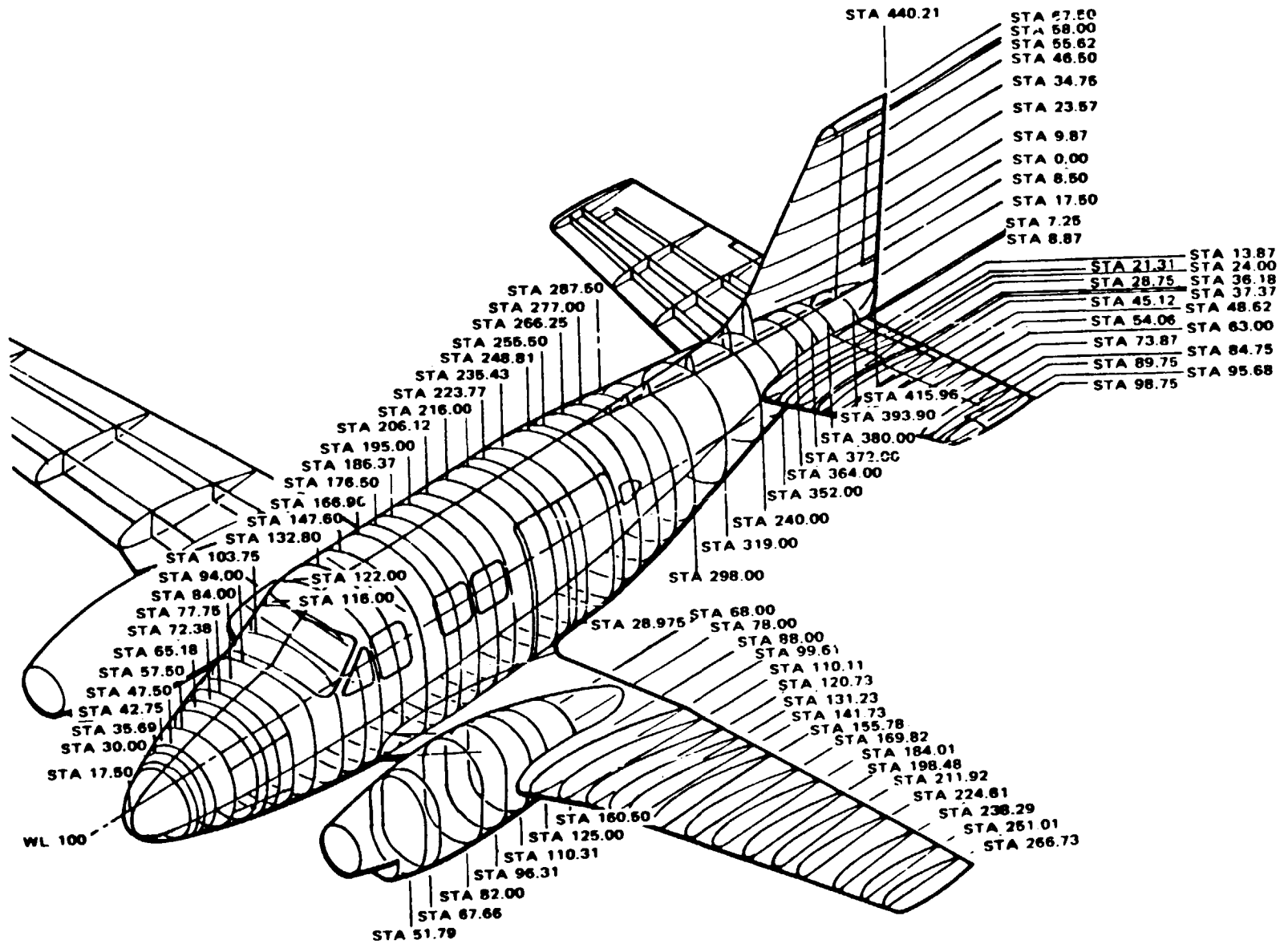


Figure 10-23. Station Diagram, U-21 and RU-21

These are the Instructions for sending an electronic 2028

The following format must be used if submitting an electronic 2028. The subject line must be exactly the same and all fields must be included; however only the following fields are mandatory:

1, 3, 4, 5, 6, 7, 8, 9, 10, 13, 15, 16, 17, and 27.

From: "Whomever" <whomever@avma27.army.mil>

To: mpmt%avma280st-louis-emh7.army.mil

Subject: DA Form 2028

1. **From:** Joe Smith
2. *Unit:* home
3. **Address:** 4300 Park
4. **City:** Hometown
5. **St:** MO
6. **Zip:** 77777
7. **Date Sent:** 19-OCT-93
8. **Pub no:** 55-2840-229-23
9. **Pub Title:** TM
10. **Publication Date:** 04-JUL-85
11. *Change Number*7
12. *Submitter Rank:* MSG
13. **Submitter FName:** Joe
14. *Submitter MName:* T
15. **Submitter LName:** Smith
16. **Submitter Phone:** 123-123-1234
17. **Problem:** 1
18. *Page:* 2
19. *Paragraph:* 3
20. *Line:* 4
21. *NSN:* 5
22. *Reference:* 6
23. *Figure:* 7
24. *Table:* 8
25. *Item:* 9
26. *Total:* 123
27. **Text:**

This is the text for the problem below line 27.

By Order of the Secretary of the Army:

JOHN A. WICKHAM, JR.
General, United States Army
Chief of Staff

Official:

R. L. DILWORTH
Brigadier General, United States Army
The Adjutant General

DISTRIBUTION:

To be distributed in accordance with DA Form 12-31, AVUM and AVIM Requirements for All Fixed and Rotary Wing Aircraft

These are the instructions for sending an electronic 2028

The following format must be used if submitting an electronic 2028. The subject line must be exactly the same and all fields must be included; however only the following fields are mandatory: 1, 3, 4, 5, 6, 7, 8, 9, 10, 13, 15, 16, 17, and 27.

From: "Whomever" <whomever@avma27.army.mil>

To: Is-Lp@redstone.armyl

Subject: DA Form 2028

1. **From:** Joe Smith
2. **Unit:** home
3. **Address:** 4300 Park
4. **City:** Hometown
5. **St:** MO
6. **Zip:** 77777
7. **Date Sent:** 19-OCT-93
8. **Pub no:** 55-2840-229-23
9. **Pub Title:** TM
10. **Publication Date:** 04-JUL-85
11. **Change Number** 7
12. **Submitter Rank:** MSG
13. **Submitter FName:** Joe
14. **Submitter MName:** T
15. **Submitter LName:** Smith
16. **Submitter Phone:** 123-123-1234
17. **Problem:** 1
18. **Page:** 2
19. **Paragraph:** 3
20. **Line:** 4
21. **NSN:** 5
22. **Reference:** 6
23. **Figure:** 7
24. **Table:** 8
25. **Item:** 9
26. **Total:** 123
27. **Text:**

This is the text for the problem below line 27.



THEN ...JOT DOWN THE DOPE ABOUT IT ON THIS FORM, CAREFULLY TEAR IT OUT, FOLD IT AND DROP IT IN THE MAIL!

SOMETHING WRONG WITH THIS PUBLICATION?

FROM: (PRINT YOUR UNIT'S COMPLETE ADDRESS)
 PFC John DOE
 CO 4 3rd Engineer Bn
 Ft. Leonardwood, MO 63108

DATE SENT
 22 August 1992

PUBLICATION NUMBER
 TM 1-1520-250-10

PUBLICATION DATE
 15 June 1992

PUBLICATION TITLE
 Operator's manual MH60K Helicopter

BE EXACT PIN-POINT WHERE IT IS

IN THIS SPACE, TELL WHAT IS WRONG AND WHAT SHOULD BE DONE ABOUT IT:

PAGE NO	PARA-GRAPH	FIGURE NO	TABLE NO
6	2-1 a		
B1		4-3	

In line 6 of paragraph 2-1a the manual states the engine has 6 cylinders. The engine on my set only has 4 cylinders. Change the manual to show 4 cylinders.

Callout 16 in figure 4-3 is pointed at a bolt. In key to figure 4-3, item 16 is called a shim. Please correct one or the other

PRINTED NAME, GRADE OR TITLE, AND TELEPHONE NUMBER

JOHN DOE, PFC (268) 317-7111

SIGN HERE

JOHN DOE *John Doe*

DA FORM 1 JUL 79 2028-2

PREVIOUS EDITIONS ARE OBSOLETE.
 DRSTS-M verprint2, 1 Nov 80

P.S. - IF YOUR OUTFIT WANTS TO KNOW ABOUT YOUR RECOMMENDATION, MAKE A CARBON COPY OF THIS AND GIVE TO YOUR HEADQUARTERS.

FILL IN YOUR
UNIT'S ADDRESS



FOLD BACK

DEPARTMENT OF THE ARMY



TEAR ALONG PERFORATED LINE



COMMANDER
US ARMY AVIATION AND MISSILE COMMAND
ATTN AMSAM-MMC-LS-LP
REDSTONE ARSENAL AL 35898-5230

FILL IN YOUR
UNIT'S ADDRESS



FOLD BACK



DEPARTMENT OF THE ARMY

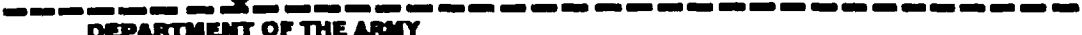
TEAR ALONG PERFORATED LINE

COMMANDER
US ARMY AVIATION AND MISSILE COMMAND
ATTN AMSAM-MMC-LS-LP
REDSTONE ARSENAL AL 36898-5230

FILL IN YOUR
UNIT'S ADDRESS



FOLD BACK



DEPARTMENT OF THE ARMY

TEAR ALONG PERFORATED LINE

COMMANDER
US ARMY AVIATION AND MISSILE COMMAND
ATTN AMSAM-MMC-LS-LP
REDSTONE ARSENAL AL 36898-5230

FILL IN YOUR
UNIT'S ADDRESS



FOLD BACK

DEPARTMENT OF THE ARMY

TEAR ALONG PERFORATED LINE

COMMANDER
US ARMY AVIATION AND MISSILE COMMAND
ATTN AMSAM-MMC-LS-LP
REDSTONE ARSENAL AL 35898-5230

The Metric System and Equivalents

Linear Measure

1 centimeter = 10 millimeters = .39 inch
 1 decimeter = 10 centimeters = 3.94 inches
 1 meter = 10 decimeters = 39.37 inches
 1 dekameter = 10 meters = 32.8 feet
 1 hectometer = 10 dekameters = 328.08 feet
 1 kilometer = 10 hectometers = 3,280.8 feet

Weights

1 centigram = 10 milligrams = .15 grain
 1 decigram = 10 centigrams = 1.54 grains
 1 gram = 10 decigrams = .035 ounce
 1 dekagram = 10 grams = .35 ounce
 1 hectogram = 10 dekagrams = 3.52 ounces
 1 kilogram = 10 hectograms = 2.2 pounds
 1 quintal = 100 kilograms = 220.46 pounds
 1 metric ton = 10 quintals = 1.1 short tons

Liquid Measure

1 centiliter = 10 milliliters = .34 fl. ounce
 1 deciliter = 10 centiliters = 3.38 fl. ounces
 1 liter = 10 deciliters = 33.81 fl. ounces
 1 dekaliter = 10 liters = 2.64 gallons
 1 hectoliter = 10 dekaliters = 26.42 gallons
 1 kiloliter = 10 hectoliters = 264.18 gallons

Square Measure

1 sq. centimeter = 100 sq. millimeters = .155 sq. inch
 1 sq. decimeter = 100 sq. centimeters = 15.5 sq. inches
 1 sq. meter (centare) = 100 sq. decimeters = 10.76 sq. feet
 1 sq. dekameter (are) = 100 sq. meters = 1,076.4 sq. feet
 1 sq. hectometer (hectare) = 100 sq. dekameters = 2.47 acres
 1 sq. kilometer = 100 sq. hectometers = .386 sq. mile

Cubic Measure

1 cu. centimeter = 1000 cu. millimeters = .06 cu. inch
 1 cu. decimeter = 1000 cu. centimeters = 61.02 cu. inches
 1 cu. meter = 1000 cu. decimeters = 35.31 cu. feet

Approximate Conversion Factors

To change	To	Multiply by	To change	To	Multiply by
inches	centimeters	2.540	ounce-inches	newton-meters	.007062
feet	meters	.305	centimeters	inches	.394
yards	meters	.914	meters	feet	3.280
miles	kilometers	1.609	meters	yards	1.094
square inches	square centimeters	6.451	kilometers	miles	.621
square feet	square meters	.093	square centimeters	square inches	.155
square yards	square meters	.836	square meters	square feet	10.764
square miles	square kilometers	2.590	square meters	square yards	1.196
acres	square hectometers	.405	square kilometers	square miles	.386
cubic feet	cubic meters	.028	square hectometers	acres	2.471
cubic yards	cubic meters	.765	cubic meters	cubic feet	35.315
fluid ounces	milliliters	29.573	cubic meters	cubic yards	1.308
pints	liters	.473	milliliters	fluid ounces	.034
quarts	liters	.946	liters	pints	2.113
gallons	liters	3.785	liters	quarts	1.057
ounces	grams	28.349	liters	gallons	.264
pounds	kilograms	.454	grams	ounces	.035
short tons	metric tons	.907	kilograms	pounds	2.205
pound-feet	newton-meters	1.356	metric tons	short tons	1.102
pound-inches	newton-meters	.11296			

Temperature (Exact)

°F	Fahrenheit temperature	5/9 (after subtracting 32)	Celsius temperature	°C
----	------------------------	----------------------------	---------------------	----

PIN: 060072-007