

STAHLWERK

MANUAL

PLASMA120

MANUFACTURER: Shenzhen Stahlwerk Welding Technology Co., Ltd.

ADDRESS: 3F, Building 11, Heng Ming Zhu Science and Technology Park, Xin Qiao Tong Fu Yu
Industrial Zone, Sha Jing Street , Bao An District, ShenZhen City

Tel: 0755-23107730

Date: 2007

SAFETY CAUTION!



On the process of welding or cutting, there will be possibility of injury. Please take protection into consideration during operation. For more details please review the Operator Safety Guide, which complies with the preventive requirements of the manufacturer

Electric shock——may lead to death !!

- Set the earth fitting according to applying standard.
- It is forbidden to touch the electric parts and electrode when the skin is bare, wearing wet gloves or clothes.
- Make sure you are insulated from the ground and the workshop.
- Make sure you are in safe position.

Gas——may be harmful to health!

- Keep your head out of the gas.
- When operating with arc welding, air extractor should be used to avoid breathing gas.

Arc radiation——harmful to your eyes and burn your skin.

- Use suitable helmet and light filter, wear protective garment to protect eyes and body.
- Use suitable helmet or curtain to protect looker-on.

Fire

- Welding spark may cause fire, make sure there is no tinder stuff around the welding area.

Noise——extreme noise will be harmful to hearing .

- Use ear protector or others means to protect ear.
- Warn that noise is harmful to hearing if there is looker-on around.

Malfunction——when trouble happens, contact the professionals

- If trouble happens during installation and operation, please follow this manual instruction to check up.
- If you fail to fully understand the manual, or fail to solve the problem with the instruction, you should contact the suppliers or our service center for professional help.
- When the use of the machine on an incline to prevent the machine overturned.



CAUTION!

Creepage-protecting switch should be added when you are using the machine!!!

ABOUT THE MACHINE

The welding machines are rectifiers adopting the most advanced inverter technology, which can apply in plasma cutting system of using pressing air.

The development of inverter gas-shielded welding equipment benefits from the development of the inverter power supply theory and components. Inverter current firstly commutates the working voltage of 50/60 Hz TO Direct Current. (DC). Then inverter gas-shielded welding power source utilizes high-power component IGBT to transfer 50/60Hz frequency, then reduces the voltage and commutates, and exports high-power voltage via PWM technology, resulting in the great reduce of the main transformer's weight and volume and the efficiency increasing by 30%. Arc initiation system adopts HF surging theory. It is easy for arc initiation and have function for early feeding air and shutting air and its characteristics are arc stable, reliable, portable, power saving and no electromagnetic noise ,high speed of cutting, the glabrous shear-out and without polish.

Plasma Cutting Machine series can product the stronger, the more concentrated and the more stable arc. The arc is pressed fiercely by the quickly flowing air and the temperature can be up to 10000-15000 centigrade degree. That forms the electrolyte estate and then form strong plasma arc. It has the functions of arc initiation current, arc stop current, welding current, basic value current, current ascending time, current descending time, gas delay time, continuous adjustment. What's more, pulse frequency and pulse duty can also be adjusted independently. It has the characteristics of automatic control of arc initiation, arc stop and stable arc, which make the best result for shape and inner quality of the welding surface. Its exclusive design is especially suitable for bicycle industry.

Compared with the others cutting machine ,the cutting machine series are using the advanced electron circuit to supply the quick power and control it .Moreover, they have top-ranking cutting operation and the extremely high transfer efficiency .

The welding machine series can easily design into different cutting power, and the output current is constant and adjustable as well as excellent operation performance. In common situation its transfer efficiency is above 85%.

The machine is used widely, it is easier to design into welding machine with different dynamic characteristics. And it can weld stainless steel, carbon steel, copper and other color metal, and also can be used for traditional electric welding.

The welding machine to meet the temperature rise of 40 degrees ambient temperature and rated load cycle requirements.

The welding machine belongs to the CISPR11 first group equipment.

Thanks for purchasing our products and hope for your precious advice. We will be dedicated to produce the best products and offer the best service.

**CAUTION!**

The machine is mainly used in industry. It will produce radio wave, so the worker should make fully preparation for protection.

PARAMETERS

Item \ Data	PLASMA 120
Power voltage (v)	400V±15%
Rated input power (kVA)	19.4
No-load voltage (v)	240
Rated input current (A)	21.7
Current Range (A)	20-120
Rated output voltage (v)	128
Duty cycle	60%
Efficiency (%)	85
Power factor	0.93
Pilot arc model	HF oscillating
Burner inter diameter (mm)	1.0
Housing Protection grade	IP21
Arcing Way	Untouched
Pressure of air compressor (kg)	4-5
Thickness (mm)	1-30
Weight (kg)	27.9
Dimensions (mm)	680*400*580

INSTALLATION

Input cable connection (enclose installing diagram)

1. Every machine has been disposed a power cable which must be connected to coordinated voltage class in compliance according to input voltage of cutting machine .If cutting machine whose power voltage is 230v is connected wrong to AC 380v ,that will cause components of inter-machine are burned up .
2. Make sure power cable is connected to power switch reliably and prevent from oxidizing .
3. Make sure power voltage is inside the waved range .

Output cable connection

1. Make sure tube of pressed air is connected to copper connector by high pressure rubber tube firmly .
2. Make sure copper screw of another end of torch is connected to electrify integration terminal then tighten them clockwise relation (prevent from leaking gas) .Mobile plug of another end of grounding cable pincer is connected to positive terminal of front panel then tighten it .
- 3 .Make sure air plug of torch is connected to switch connector of panel (If it is arc-supporting cutter ,arc-supporting cable of torch is connected to terminal of arc-supporting .)

4. show as the right picture:

1. welding postive output
2. keeping arc output

Attention:please keep the order: connect the postive output first, then connect the keeping arc output.

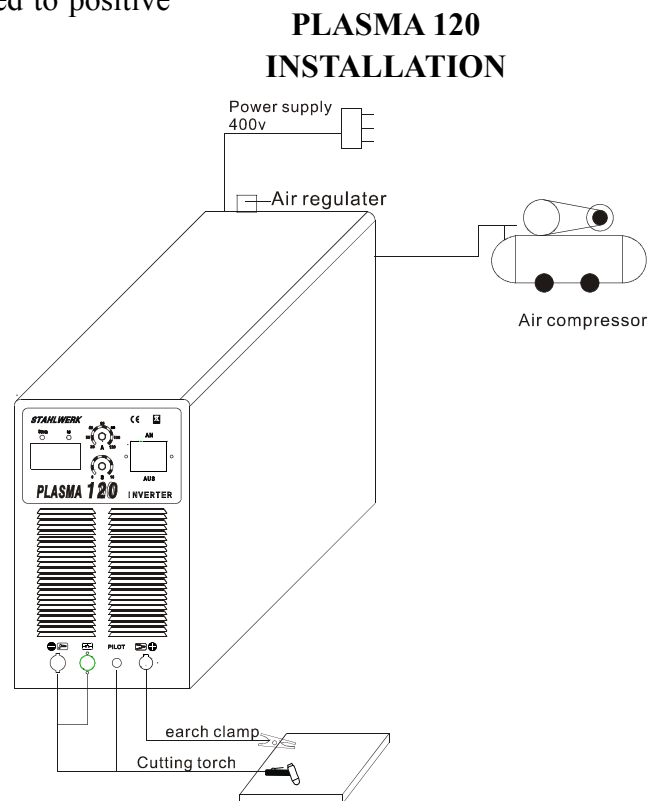

Air regulator

Air regulator installation and operation

1. Firmly tight and seal the copper air hole at IN and OUT terminal . by high pressure rubber tube firmly .
2. Tighten the meter with meter face rubber tube.
3. Fix the connecting shelf with screw as the regulator position.
4. Get down the plastic screw and fix the regulator on the shelf.
5. Turn on the air valve, turn up the pressure adjusting knob, Turn the pressure to rated volume(meter inside shows kg), and then put down the knob.(+ means increasing pressure, -- means decreasing pressure.)
6. Scale of the meter is as follow.The volume in the picture is 6 kg.
7. If the water in the gas filtering bottle is too much, please turn on the water valve to let the water go out.

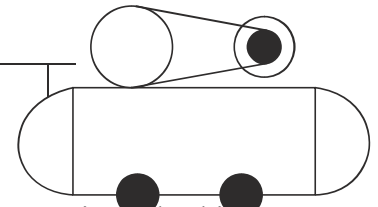

Air compressor

Regulator installation

6. Scale of the meter is as follow.The volume in the picture is 6 kg.
7. If the water in the gas filtering bottle is too much, please turn on the water valve to let the water go out.

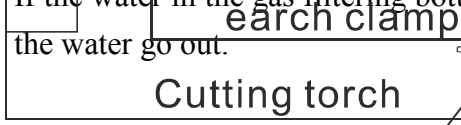

Cutting torch

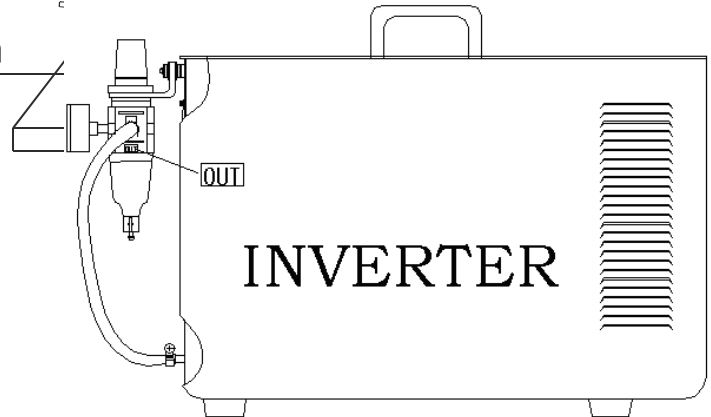

INVERTER

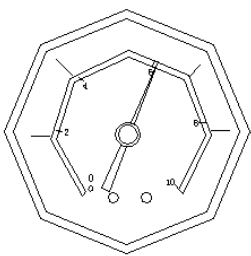

Pressure meter face

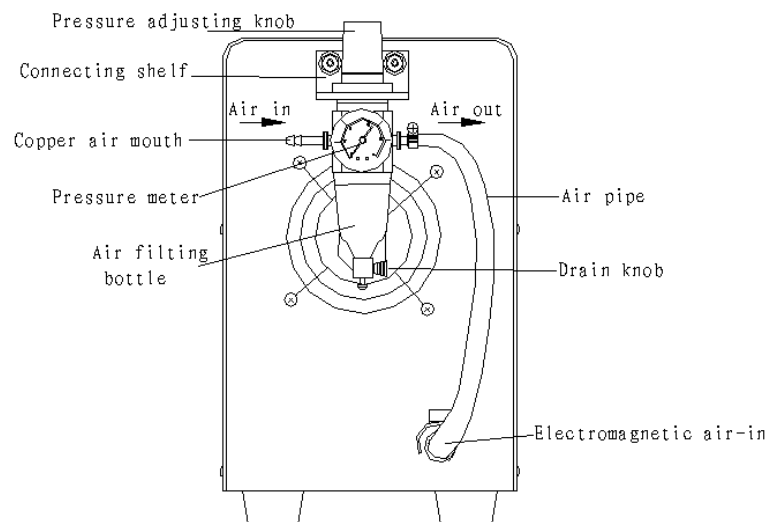

OPERATION

1. Open the power switch of front panel, make the power switch is in “on” position .At this time indicator of power switch is on .The screen will show the current volume .
2. Adjust the gas pressure to be adequate to machine , open the valve of pressed air .
3. Press the control knob of torch, electromagnetic valve is starting ,sound of HF arc-striking can be heard and burner of torch should flow out gas (Burner of arc-supporting cutter should spurt fire)
4. It is 1mm from copper tip to work piece (it is further if it is arc-supporting cutter),press knob of torch and burn and strike arc ,sparks of HF arc-striking will diminished immediately .Welding machine can begin to cut .

PLASMA120 Control panel:

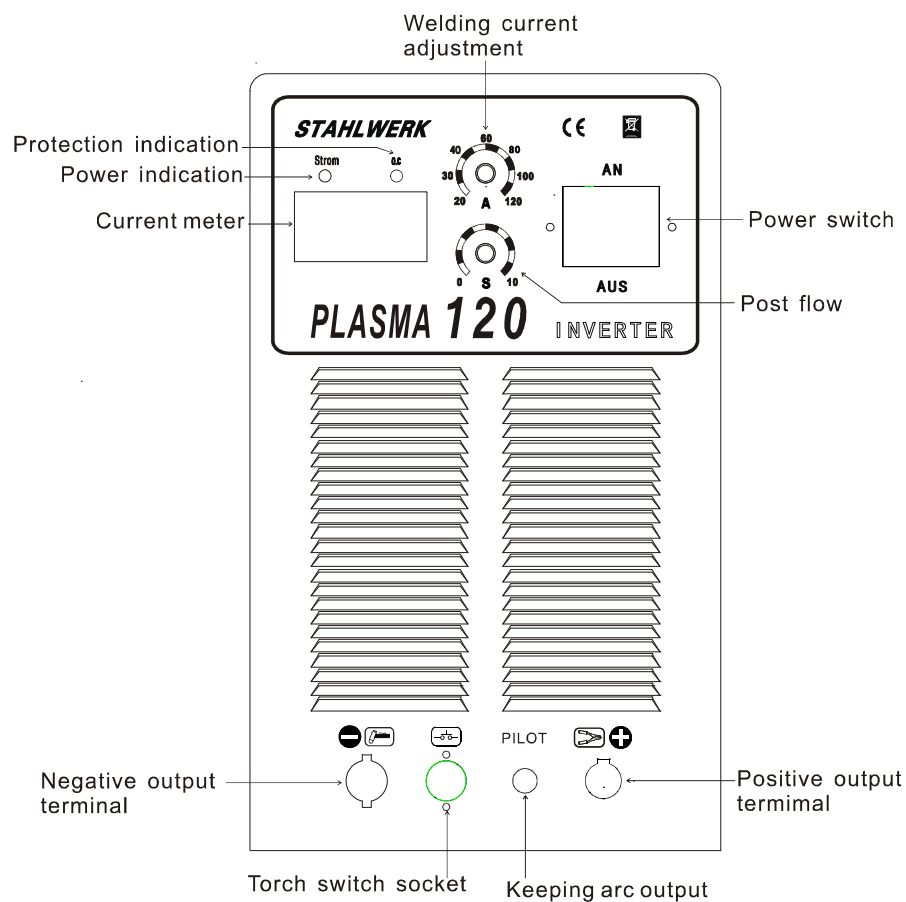

NOTICE:

In order to let Plasma cutting machine to reach its best capacity and result, current and air pressure must be matched well. So when the current is set, the pressure and flow must be adjusted suitably. If the air flow is too big and cooling effect is too strong, it will cause arc pause, and if the air flow is too small, the nozzle and electrode will be too hot and burnt out.



1、 Environment

- 1) The machine can be performed in environment where conditions are dry with a dampness level of max 90%.
- 2) Ambient temperature is between -10 to 40 degrees centigrade.
- 3) Avoid welding in sunshine or drippings condition.
- 4) Do not use the machine in environment where condition is polluted with conductive dust in the air or corrosiveness gas on the air.
- 5) Avoid gas welding in the environment of strong airflow.

2、 Safety norms

The cutting machine has been installed protection circuit of over voltage and over current and over heat. When voltage and output current and temperature of machine are exceeding the rate standard, welding machine will stop working automatically. Because that will be damage to welding machine, user must pay attention to the following notice.

1) **The working area is adequately ventilated !**

The cutting machine is powerful machine, when it is being operated, it is generated by high currents, and natural wind will not satisfy machine cool demands. So there is a fan in inter-machine to cool down machine. Make sure the intake is not in block or covered, it is 0.3 meter from welding machine to objects of environment. User should make sure the working area is adequately ventilated. It is important for the performance and the longevity of the machine.

2) **Do not over load !**

The operator should remember to watch the max duty current (Response to the selected duty cycle).

Keep welding current is not exceed max duty cycle current.

Over-load current will damage and burn up machine.

3) **No over voltage !**

Power voltage can be found in diagram of main technical data. Automatic compensation circuit of voltage will assure that welding current kept in allowable arrangement. If power voltage is exceeding allowance arrangement limited, it will damage the components of machine. The operator should understand the situation and take preventive measures.

- 4) There is a grounding screw behind welding machine, with grounding marker on it. Mantle must be grounded reliable with cable which section is over 6 square millimeter in order to prevent from static electricity and leaking.

- 5) If welding time is exceeded duty cycle limited, welding machine will stop working for protection. If the machine is overheated, temperature control switch is on "ON" position and the indicator light is red. In this situation, you don't have to pull the plug, in order to let the fan cool the machine. When the indicator light is off, and the temperature goes down to the standard range, so it can weld again.

QUESTIONS IS BE RUN INTO DURIGN WELDING

Fittings, welding materials, environment factor, supply powers maybe have something to do with welding. User must try to improve the level of welding environment.

A、Cutting surface is rough, poor cutting result

The machine may be not well operated. You can check it as follow:

1. Make sure the compressed air supply has enough pressure which is not less than 0.3MPa ($3\text{kg}/\text{cm}^2$), and its range is $\pm 0.05\text{Mpa}$.
2. Electrode and nozzle are not matched with current. Check as follow:

Current	10-30A	30-40A	60-100A	100-120A
Nozzle	$\phi 1.0\text{mm}$	$\phi 1.2\text{mm}$	$\phi 1.3\text{mm}$	$\phi 1.4\text{mm}$

B、Arc-striking is difficult and easy to pause:

1. Make sure quality of tungsten electrode is high.
2. Cutting current is too small and air flow is too big. And if cooling effect is too strong, it will lead to arc pause.
3. Power net voltage is low and input cable is too long.

C、Output current is not up to the rated value:

When power voltage departs from the rated value, it will make the output current not matched with rated value; When voltage is lower than rated value, the max output may be also lower than rated value.

D、Current is not stabilizing when machine is been operating:

It has something to do with factors as following:

1. Electric wire net voltage has been changed.
2. There is harmful interference from electric wire net or other equipment.

E、Electrode or nozzle burnt often:

1. Current is too big or nozzle is too small.
2. Air pressure is low and cooling effect is weak and nozzle is too hot.

F、Arc can not cut into the steel plate fully, or too much spatter.

1. Maybe the machine capacity can not meet the demand of that thickness, please use bigger machine.
2. Electrode or nozzle is burnt, please change it.



For normal operation you should cut from the edge of the work piece, in this way you can protect the torch from damage by spatter conglutination.

MAINTENANCE

**CAUTION:**

Before maintenance and checking, power must be turned off, and before opening the housing, make sure the power plug is pulled off..

- 1、 Remove dust by dry and clean compressed air regularly, if welding machine is operating in environment where is polluted with smokes and pollution air, the machine need removing dust everyday.
- 2、 Pressure of compressed air must be inside the reasonable arrangement in order to prevent damaging to small components of inter-machine.
- 3、 Check inter circuit of welding machine regularly and make sure the cable circuit is connected correctly and connectors are connected tightly (especially insert connector and components). If scale and loose are found, please give a good polish to them, then connect them again tightly.
- 4、 Avoid water and steam enter into inter-machine, if they enter into machine, please dry inter-machine then check insulation of machine.
- 5、 If welding machine will not be operated long time, it must be put into packing box And store in dry environment.
- 6、 When wire machine operates for every 300 hours, the electric carbon brush and armature rectifier should be polished, the reducer should be cleaned, and lubricator should be added to the turbo and bearing.

BEFORE CHECKING

**WARNING**

Blind experiment and careless repair may lead to more problem of the machine that will make formal check and repair more difficult. When the machine is electrified, the naked parts contain life-threatening voltage. Any direct and indirect touch will cause electric shock, and severe electric shock will lead to death.

i Notice: In the period of guarantee maintenance, if user makes wrong check and repair for the induction power without our permission, the free maintenance guarantee offered by the supplier will be invalid.

CHECK FAULT



Notes: If user wants to operate machine as following, the operator must be a personnel in a specific field of electricity and safety and hold the relevant certificate that proves their ability and knowledge. Before maintenance, contacting with our company for authorization is suggested.

Faults	Resolvable Methods
1. Switch indicator is on, fan is not working and control knob is out of work.	1. Over voltage protection is working. Close machine then Open it again after several minutes.
2. Switch indicator is lit and fan is working. However, press control knob of torch, there is no HF arc-striking sound and electromagnetic valve is not working.	1. Check if torch is open circuit. 2. Check if control knob of torch is damaged. 3. Part of assistant power of top board is damaged and there is no DC 24V output.
3. Switch indicator is lit and fan is working. However, press control knob of torch, there is no HF arc striking sound and inter red diode is lit.	1. Check if MOS K4107 of top board is damaged (driver mould is damaged). 2. Rising transformer of bottom board is damaged. 3. Control mould is damaged.
4. Switch indicator is lit and fan and electromagnetic valve are working. However, there is no sound of HF arc-striking and inter red diode is not lit.	There is some trouble in part of arc-striking, such as: 1. It is too far between discharge tip or there is adhesion in discharge tip. 2. Primary coil of arc-striking transformer is damaged or poor contact. 3. Check if four times voltage rectifier diode is stricken. 4. Check if HF electric capacity 102/10KV is leaking. Relay is damaged.

If after checking and adjustment it still can not work normally, please contact the local distributor or our service center.