

T610. OUR BEST TRUCK YET.



KENWORTH

AUSTRALIAN MADE. WORLD'S BEST.

THIS IS WHERE THE NEW ERA BEGINS

Its on-road presence is bold. Its aerodynamics are advanced. The DNA is unmistakable—this new T610 is every inch a Kenworth. And with up to 600Hp at your disposal, it's ready for whatever task lies ahead.

Inside, the T610 introduces a revolutionary new dimension in driver comfort and ergonomics. More spacious, better equipped and manufactured to the most exacting quality standards in Kenworth's history, its new enhanced cabin delivers the ultimate driver experience.

There's been nothing left on the drawing board when it comes to safety. Available with state-of-the-art collision avoidance technology, it can monitor road and traffic conditions constantly to prevent, and protect you from potentially hazardous situations.

The new T610 is also one of the most aerodynamic and fuel efficient production trucks ever to carry the iconic Kenworth badge. It is powered by the Cummins X15 Euro V engine with Advanced Dynamic Efficient Powertrain (ADEPT) technology, a suite of electronic features that interact with Eaton automated manual transmissions, dynamically adapting to operating conditions to enhance fuel economy with no impact on productivity.

Versatility is another T610 hallmark. Offered in either a day cab or 860mm sleeper option, the T610 is suitable for virtually any application, and made to measure for line haul, including maximum payload 26-metre B-Double configurations. The T610SAR with its classic Kenworth styling is as tough as it is durable, and the set forward front axle makes it an ideal workhorse for 19-metre B-Double, and tipper and dog applications.



THIS IS NEXT LEVEL SOPHISTICATION



Designed from the inside out, the new Kenworth cabin is centred completely around the needs of the driver.

Significantly wider and with increased walkthrough space between seats, greater room head-to-toe for the driver, and more standing room in the sleeper cabs, the interior feels more open, more relaxed and is far easier to move around in. There's more storage—all of it positioned for maximum convenience.

Driver comfort is enhanced by an advanced heating and air-conditioning system with automatic climate control. More powerful yet more efficient, it maintains optimum cabin temperature at all times, in all driving conditions, all year round.

The T610 cabin boasts new triple sealed doors and door apertures—an innovation that minimises noise and dust leaks, and whose quality construction you'll feel and hear, each time the doors close.

Behind the wheel you immediately feel in command. The more expansive windscreen offers a panoramic view of the road, while the cabin's superior ergonomics mean switchgear and controls are positioned intuitively, and that dashboard instrumentation is visible at a glance.



T610

THIS IS HOW HISTORY IS MADE

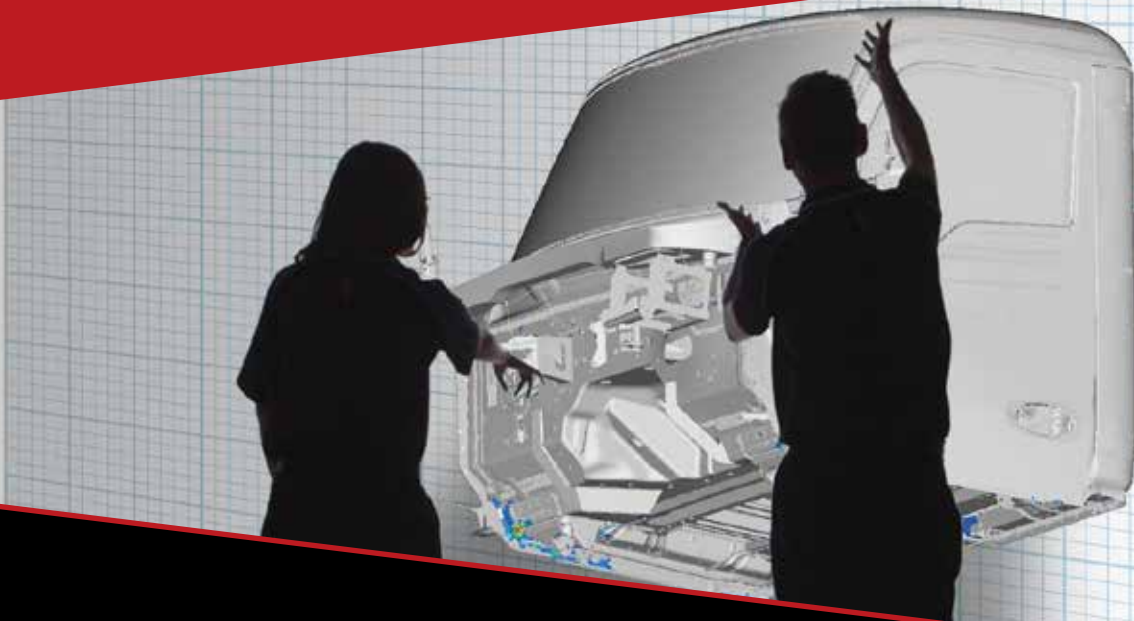

For more than 40 years, Kenworth has worked to develop some of the most innovative, durable and productive trucks in the history of Australian and New Zealand road transport.

Tasked with creating the ultimate driver experience, the T610 design team first enlarged the cabin envelope, then moved the entire cabin forward to achieve the optimal BBC lengths needed for maximum payloads in New Zealand.

The newly designed dashboard and stylish interior trim complete the picture, but as is often the case with Kenworth, what you can't see is just as important.

Like the enhanced cooling package to comfortably handle 600Hp output, or the simplified accessibility to key vehicle systems. The heavy duty firewall for ultimate reliability, or the advanced air flow design that reduces heat penetration to the cab.

You won't see the 100,000 Australian design hours invested in the T610, either. Or the more than 10,000,000 kilometres of testing and validation. But when you experience this new Kenworth in action—year in, year out—you'll certainly appreciate them.

Rest assured—whether you opt for the versatile T610, or the hard yards specialist T610SAR with its set forward front axle, and external air cleaners—you will be the owner of our best truck yet.



THIS IS QUALITY AND FLEXIBILITY

MAIN SPECIFICATIONS AND OPTIONS

CONFIGURATION	T610	T610SAR
6X4	Standard	Standard
8X4	Optional	-
ENGINE	T610	T610SAR
X15 Euro V 485HP / 1650LBFT TORQUE	Standard	Standard
X15 Euro V 485HP - 600HP / 1850LBFT TORQUE	Optional	Optional
X15 Euro V 600HP / 2050LBFT TORQUE	Optional	Optional
EXHAUST	T610	T610SAR
EGP MOUNTED RIGHT HAND SIDE UNDER CAB	Standard	Standard
EGP MOUNTED IN CHASSIS	Optional	Optional
UREA	T610	T610SAR
100L 625MM DIA UREA TANK	Standard	Standard
170L 625MM DIA UREA TANK	Optional	Optional
300L 625MM DIA UREA TANK	Optional	Optional
160L RECTANGULAR UREA TANK	Optional	Optional
225L RECTANGULAR UREA TANK	Optional	Optional
AIR CLEANER	T610	T610SAR
DONALDSON 2540 AIR CLEANER MOUNTED UNDER HOOD	Standard	-
STAINLESS STEEL COWL MOUNTED	-	Standard
DUAL DONALDSON ERA COWL MOUNTED	-	Optional
TRANSMISSION — MANUAL	T610	T610SAR
EATON RTLO16918B	Standard	Standard
EATON RTLO18918B	Optional	Optional
EATON RTLO20918B	Optional	Optional
EATON RTLO22918B	Optional	Optional
TRANSMISSION — AUTOMATED	T610	T610SAR
ULTRASHIFT PLUS FO-16E318B-MXP	Optional	Optional
ULTRASHIFT PLUS FO-18E318B-MXP	Optional	Optional
ULTRASHIFT PLUS FO-20E318B-MXP	Optional	Optional
ULTRASHIFT PLUS FO-22E318B-MXP	Optional	Optional
FRONT AXLE	T610	T610SAR
MERITOR MFS66-122	Optional	Optional
MERITOR MFS73	Optional	Optional
MERITOR DUAL MFS66-122	Optional	-
REAR AXLE	T610	T610SAR
MERITOR RT40-145	Optional	Optional
MERITOR RT46-160	Optional	Optional
MERITOR RT50-160	Optional	Optional
MERITOR RT52-185	Optional	-
REAR SUSPENSION	T610	T610SAR
KENWORTH AIRGLIDE 400	Standard	Standard
KENWORTH AIRGLIDE 460	Optional	Optional
KENWORTH KW6-60A	Optional	Optional
NEWAY AD246/10	Optional	Optional
SAFETY SYSTEMS	T610	T610SAR
EBSS	Standard	Standard
- ANTILOCK BRAKING SYSTEM	Standard	Standard
- AUTOMATIC TRACTION CONTROL	Standard	Standard
- DRAG TORQUE CONTROL	Standard	Standard
ESP - ELECTRONIC STABILITY PROGRAM	Optional	Optional
TRM - TRAILER RESPONSE MANAGEMENT	Optional	Optional
ACB - ACTIVE CRUISE BRAKING WITH COLLISION MITIGATION	Optional	Optional
LANE DEPARTURE WARNING	Optional	Optional
BRAKES	T610	T610SAR
DRUM	Standard	Standard
DISC	Optional	Optional
WHEELS	T610	T610SAR
ALCOA 10 STUD	Optional	Optional
SLEEPER	T610	T610SAR
860mm AERO FLAT BACK	Optional	Optional
FUEL TANKS	T610	T610SAR
RANGE OF PACKAGES AVAILABLE		

T610 DAY CAB

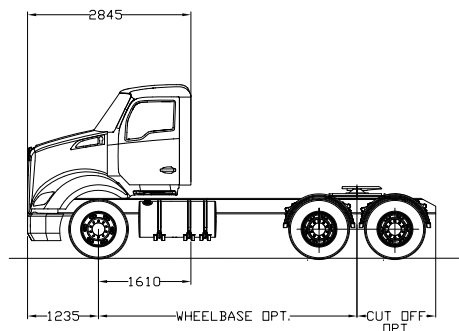

T610 860MM SLEEPER

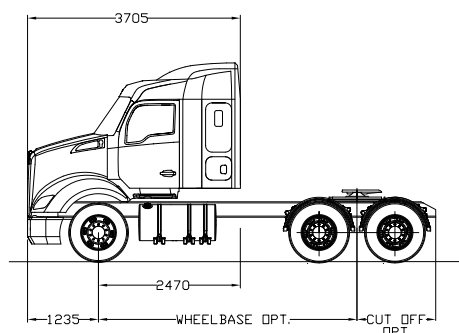

T610SAR DAY CAB

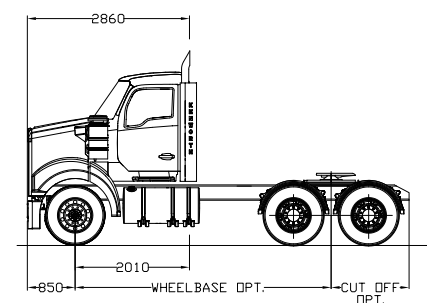

T610SAR 860MM SLEEPER

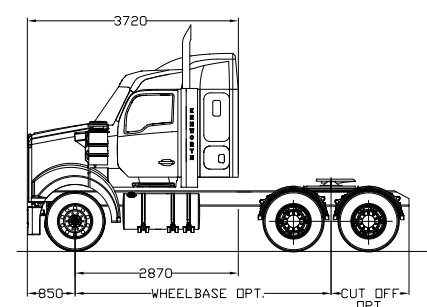

T610 DAY CAB

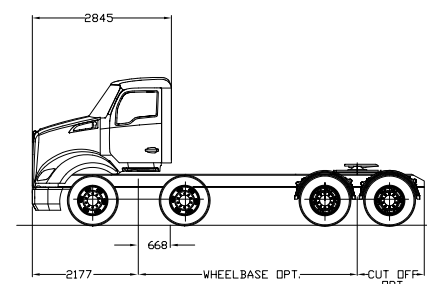

NATIONWIDE SUPPORT NETWORK

NORTH ISLAND PARTS AND SERVICE DEALERS

Whangarei

Commercial Diesel
(09) 438 6915

Warkworth

Commercial Diesel
(09) 425 8456

Auckland

Southpac Trucks Parts
(09) 263 7710

Auckland

Southpac Trucks Service
(09) 262 4644

Hamilton

Southpac Trucks
(07) 222 2080

Mt Maunganui

Truckline Services
(07) 575 3883

Rotorua

Southpac Trucks
(07) 345 9761

Gisborne

Total Parts & Service
(06) 867 0707

Taupo

Taupo Diesel Solutions
(07) 377 4324

New Plymouth

McCurdy Engineering
(06) 769 6506

Napier

Eastern Truck & Marine
(06) 843 0400

Wanganui

Emmetts Truck Services
(06) 344 5055

Palmerston North

Emmetts Truck Services
(06) 354 2691

Masterton

Fagan Trucks
(06) 378 6159

Wellington

Goughs Wellington
(04) 569 1099



SOUTH ISLAND PARTS AND SERVICE DEALERS

Nelson

Commercial Vehicle Centre
(03) 546 4605

Blenheim

Vent
(03) 578 9574

Christchurch

Southpac Trucks
(03) 344 0252

Christchurch

Heavy Diesel Parts & Services
(03) 349 2009

Timaru

Heavy Diesel Parts & Services
(03) 686 6663

Dunedin

Dunedin Truck Servicing
(03) 479 0150

Gore

Transport Repairs 2003 Gore
(03) 208 1618

Invercargill

Transport Repairs 2003 Invercargill
(03) 208 1618

Cromwell

Transport Repairs 2003 Cromwell
(03) 208 1618



24 HOUR ASSIST 0508 225 577



IMPORTANT: The vehicles shown in this brochure are for illustrative purposes only and may include some non-standard optional equipment. All weights and measurements should be regarded as approximate only. For full details contact your Kenworth Dealer. In the interests of product improvement, Kenworth reserves the right to change these specifications without prior notice.

