



THE FAIREY ROTODYNE

The Rotodyne represents an entirely new approach to air transport, and its amazing performance is a triumph for the British Aircraft Industry.

It is the first true vertical take-off airliner, and is capable of carrying a full load of passengers or freight, operating from airfields no larger than two tennis courts. Unlike the conventional helicopter the Rotodyne is economical to operate, and also capable of much higher speeds and greater range.

The prototype Rotodyne, built under a Ministry of Supply contract, first flew on 6th November, 1957, and achieved its first transition to complete autorotative flight in April, 1958. This prototype, the subject of this model, is capable of carrying 48 passengers or five tons of freight; the eventual production version will be larger, carrying up to 70 passengers or 8 tons of freight, and will be powered by the more powerful Rolls-Royce Tyne engines in place of the present Elands.

A striking demonstration of the Rotodyne's performance was given in January, 1959, when it set up a record 191 m.p.h. on a 100 km. closed circuit. This exceeds the previous record by 49 m.p.h., and is even 29 m.p.h. faster than the previous absolute speed record for helicopters. This speed, together with the range of 450 miles, to be increased to 650 miles in the developed version, and of course the weight-lifting and vertical take-off performance, puts the Fairey Rotodyne into a class of its own. Already three airline operators have indicated their intention of buying the Rotodyne, and great interest is being shown by civilian and military operators throughout Europe and America.

The Rotodyne takes off vertically, as does a helicopter, and then flies forward as a fixed wing aircraft. To do this the two propeller-turbines are initially used as compressors feeding air along the wings into the rotor hub, and from there through pipes in the rotor blades to the pressure jet units at the tips. The compressed air is then mixed with kerosene and ignited, producing jet power to turn the rotor. When the rotor is running at full speed the Rotodyne takes off and climbs as a helicopter. As height is gained the engine power is transmitted to the propellers and the rotor de-clutched. This leaves the rotor to "free-wheel," and the wings take over more part in supporting the aircraft, until at 181 m.p.h. the wings are providing 60% of the lift.

The prototype Rotodyne is powered by two Napier Eland propeller-turbines each of 2,800 s.h.p., and four Fairey Pressure Jets, each delivering 1,000 lbs. thrust at take-off. Overall fuselage length is 58ft. 8in., wing span 46ft. 6in., and the rotor diameter is 90ft.

ALL AIRFIX AIRCRAFT CONSTRUCTION KITS IN SERIES (1, 2, 3, 4 & 5) ARE MADE TO A CONSTANT 1/72 SCALE. ALL MODELS ARE DESIGNED WITH THE SAME SKILL AND ATTENTION TO DETAILS SO THAT A LARGE AND VARIED COLLECTION CAN BE BUILT UP. EACH MODEL IS TRUE TO SCALE AND REALISTIC IN RELATIONSHIP TO ALL OTHER MODELS. OTHER FINE AIRFIX CONSTRUCTION KITS ARE AVAILABLE IN VARIOUS SERIES SUCH AS HISTORICAL SHIPS, OO TRACKSIDE HOUSES AND ACCESSORIES, 1/32 VINTAGE CARS AND 1/12 MODEL FIGURES. A LIST OF THE MANY OTHER AIRFIX MODELS WHICH YOU CAN MAKE WILL BE FOUND ON A SLIP IN THIS PACKAGE.

INSTRUCTIONS

It is recommended that the instructions and exploded view are studied before assembly. If it is wished to paint internal details such as crew and cockpit interior, this should be done before assembly.

1. Insert the windows into the insides of the locating holes, so that the surrounds are projecting inside the fuselage walls, and cement in place, applying cement to the window surrounds only (1-22).
2. Lay the forward (longer) hinges in place in the locating channels in the starboard fuselage rear, ensuring that the hinge pins are facing inwards, then cement the hinge covers in place over the locating strips, ENSURING NO CEMENT COMES INTO CONTACT WITH THE HINGES (23-26).
3. When the hinge covers are set, pull back the hinges and press the rear (shorter) hinges on to the projecting pins (27 & 28).
4. Press the hinges back into the fuselage to the limit of their movement, then cement the rear hinges to the inside of the starboard tail door (29).
5. Repeat this procedure for the port side hinges and door (30-36).
6. Locate and cement seats in locating holes in fuselage floor (37, 38 & 39).
7. Cement pilot and second crew member on seats (40 & 41).
8. Cement floor into rear bulkhead location, between step and pivot boxes (42).
9. Cut out and cement printed detail to instrument panel, and cement locating tab beneath panel into slot in floor (43).
10. Press together top legs of nose undercarriage and spring into pivot boxes on bulkhead, cement wheels on to protruding axles (44-46).
11. Cement assembled floor and bulkhead in position in starboard fuselage front, ensuring bulkhead is cemented on to front of locating strip in fuselage.
12. Cement together upper and lower halves of rotor head (47 & 48).
13. Insert rotor pin through rotor head and cement spinner on to protruding head of rotor pin (49 & 50).
14. Lay rotor pin in location in starboard fuselage and cement in position, ENSURING NO CEMENT COMES INTO CONTACT WITH ROTOR HEAD.
15. Cement together the two fuselage halves, applying cement only to edges of fuselage.
16. Cement together upper and lower halves of port tailplane (51 & 52).
17. Cement tailplane into fuselage slot, at the same time locating the moving elevator in the holes in tailplane and fuselage (53).
18. Cement together port and starboard halves of upper fin, and cement on to end of tailplane (54 & 55).
19. Cement together port and starboard halves of lower fin, and locate and cement into slot beneath tailplane (56 & 57).
20. Locate tailbrace in holes in rear fuselage and lower fin and cement in place (58).
21. Cement rudder into locating holes in lower fin, setting at the desired angle (59).
22. Repeat the above procedure for the starboard tail assembly (60-68).
23. Cement cockpit in place, applying cement carefully to edges only (69).
24. Locate and cement together upper and lower halves of port wing (70 & 71).
25. Similarly cement together starboard wing halves (72 & 73).
26. Locate and cement wings into fuselage slots.
27. Place one end of undercarriage leg pivot into locating box in inner half of port nacelle, and cement on outer half of nacelle, ensuring that the undercarriage pivots are located in both boxes, ENSURING NO CEMENT COMES INTO CONTACT WITH MOVING UNDERCARRIAGE LEG (74, 75 & 76).
28. Locate and cement port and starboard exhausts into locating holes in nacelle sides (77 & 78).
29. Insert propeller pin through rear of engine front and cement into propeller spinner, ensuring no cement comes into contact with engine front, cement assembly on to nacelle (79, 80 & 81).
30. Cement air intake in position over nacelle and locator on engine front, and cement completed nacelle in position beneath port wing (82).
31. Repeat the above procedure for the starboard engine unit (83-91).
32. Cement the main wheels on to protruding axles (92-95). The desired undercarriage position should be selected.
33. For a model with retracted undercarriage (in flying position) the main undercarriage legs should be retracted into the nacelles, the large front undercarriage doors cemented flush with the nacelle over the leg, and the smaller rear doors cemented flush over the wheels. For a model standing upon its undercarriage these doors are all cemented in the open position, hanging vertically down beneath the nacelles, located in the slots in front of and behind the undercarriage (96-101).
34. The nose wheel doors should similarly be cemented in the selected position, the smaller doors in front of the undercarriage leg and the larger door behind (102-104).
35. Cement the halves of the rotor tip jets on to the ends of the rotors, then push the rotor blades into the hub, cementing if desired; ensure all blades are located so as to face the correct direction of rotation (anti-clockwise) (105-112).
The balance of the model should now be ascertained. If it does not stand upon its undercarriage the nose should be weighted by inserting Plasticine into the front fuselage by means of the nose door, before fixing the nose door assembly.
36. Cement the stairway on to the lower nose door half (113-114).
37. If the door is required closed, the lower door should be cemented into the door opening, lying flush with the fuselage and the upper door cemented into the top half of the opening. If open doors are chosen, the lower door is cemented on to the bottom of the opening, so that the steps reach the ground and the upper door is cemented to the top of the opening, projecting at right angles to the fuselage.
N.B. If an open door is selected the doors must first be laid in position while the paint and transfers are applied over them, then separated after cutting the dry transfers with a razor blade (115).
NOTE. If it is wished to paint the model it should be done at this stage, using the colour scheme overleaf and the painting notes below.
38. Apply transfers. First cut the sheet into twenty-one separate subjects. Then dip each in warm water for a few minutes, slide off backing into position shown on illustration. The six plain blue and white trim lines are applied to the fuselage sides, below the windows from the cockpit to the extreme rear of the doors, and above the windows from the doors to the centre section. The trim lines with the short end bars are applied above the windows forward of the centre section. The wide bands are applied around each upper fin with the serial numbers immediately below. The large name transfers are applied to either side of the fuselage below the windows, the smaller name transfers with attached insignia are applied on either side of the rotor fairing. The narrow white strips with insignia are applied centrally to either side of the fuselage, forward of the windows, and the two remaining white strips centrally aft of the windows.

DETAIL—SUGGESTED COLOURS Tyres: Black. Exhausts: Light Grey. Crew: Dark Blue uniform, white shirts.

N.B.—For painting use AIRFIX Painting Packs. For Fixing use AIRFIX Polystyrene Cement.

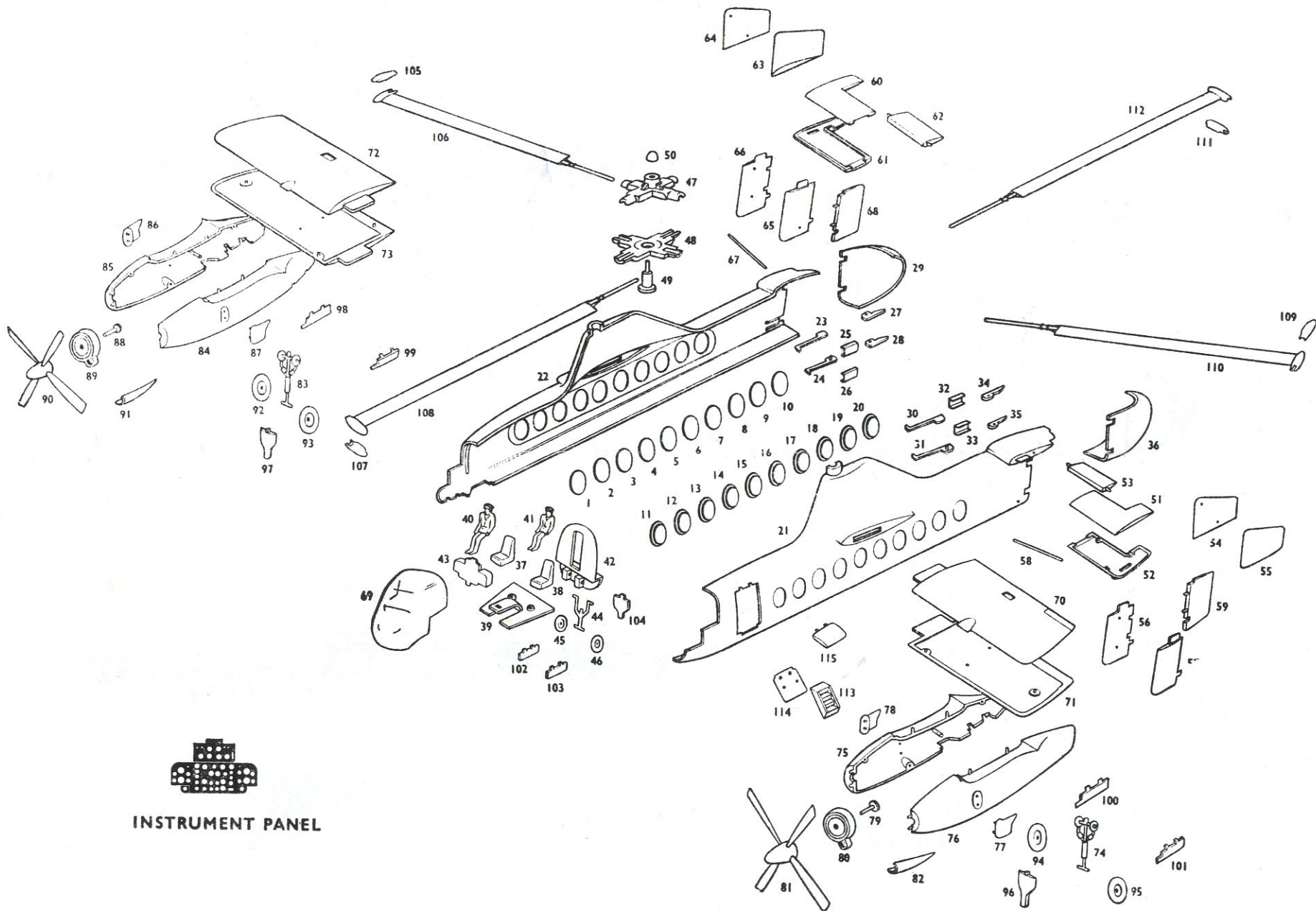

INSTRUMENT PANEL

COLOUR SCHEME

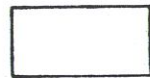
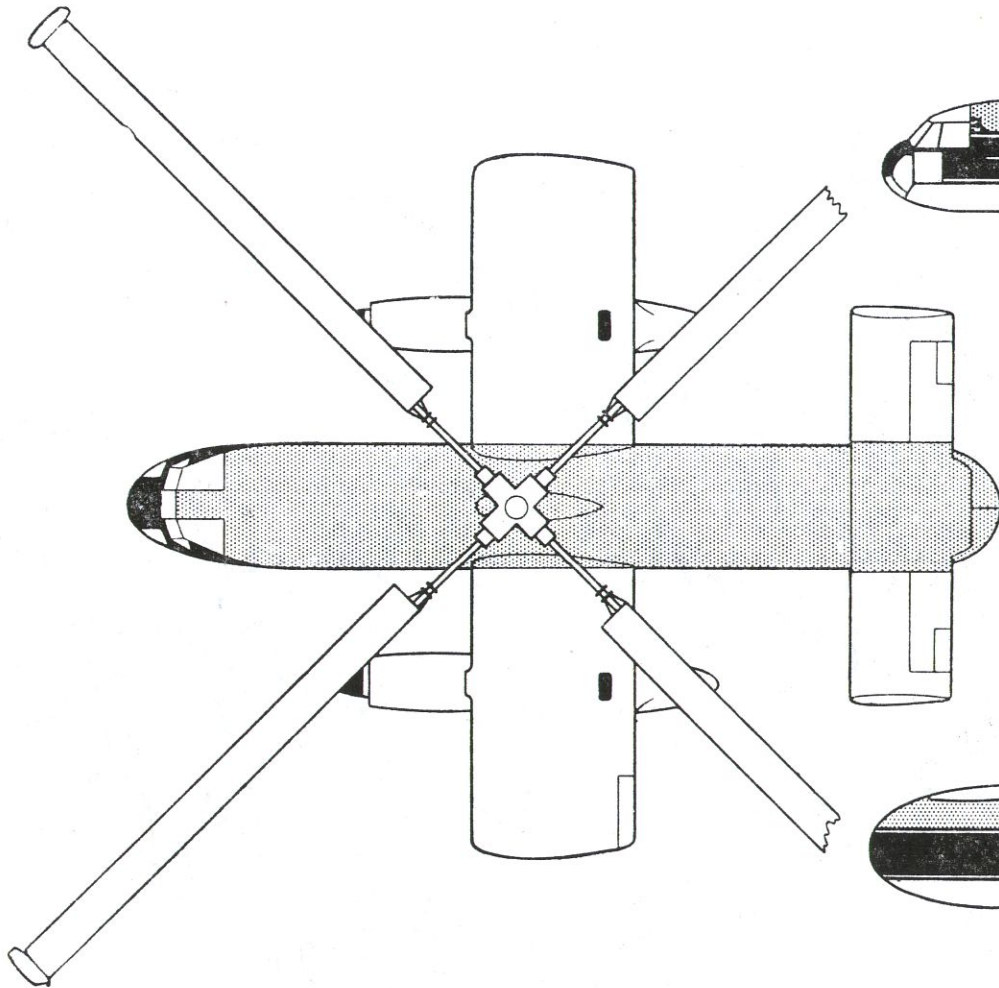
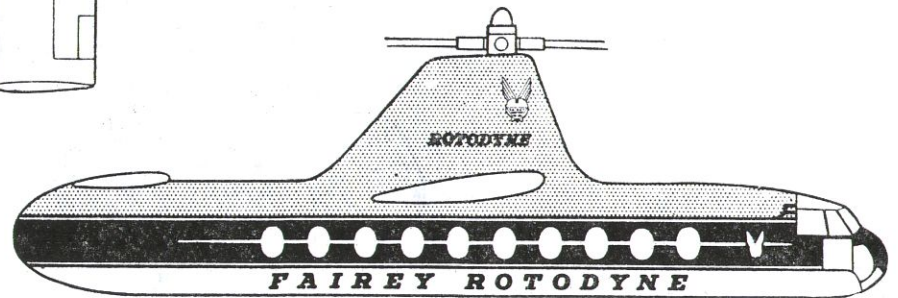
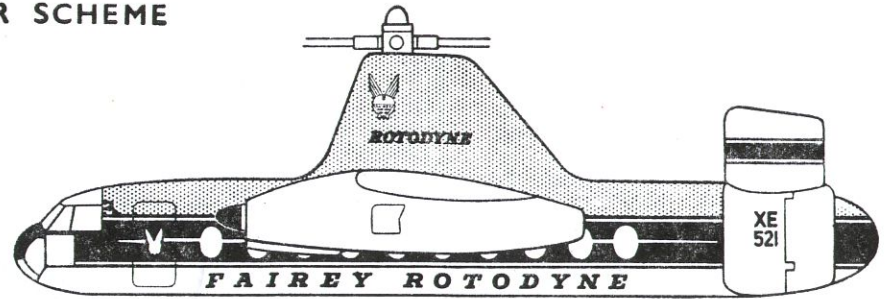

SILVER



WHITE



ROYAL BLUE

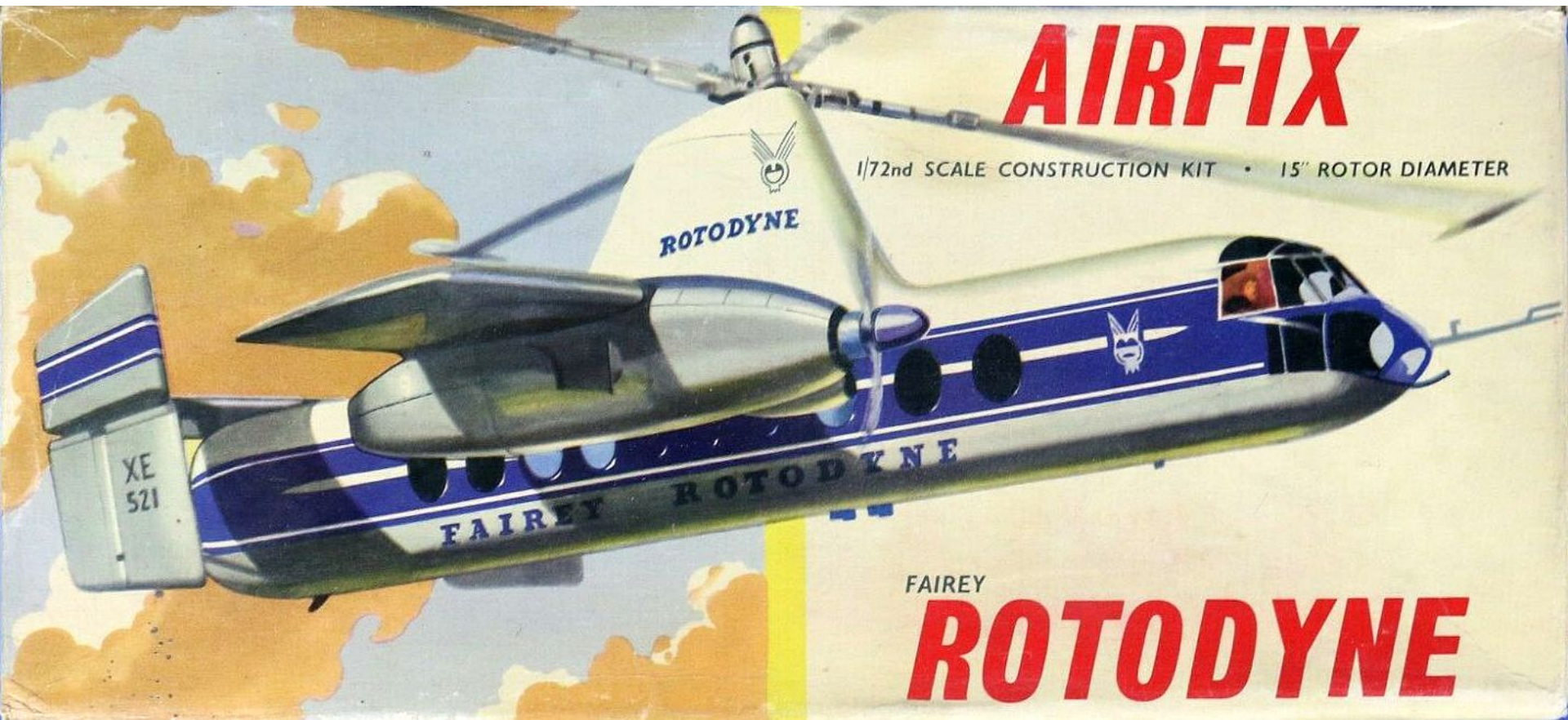

AIRFIX

1/72nd SCALE CONSTRUCTION KIT • 15" ROTOR DIAMETER

ROTODYNE

XE
521

FAIREY ROTODYNE

FAIREY

ROTODYNE